

# PHILIPS

Television  
6700 Series

# User Manual

32PQT6731/68  
43PQT6731/68

Register your product and get support at  
[www.philips.com/TVsupport](http://www.philips.com/TVsupport)

# Content

---

1. Home Screen	4	10. Display & Sound	13
1.1 Introduction	4	10.1 Display	13
1.2 Dashboard and Settings	4	10.2 Screen	14
1.3 Open the home screen	4	10.3 Sound	14
		10.4 Audio Output	15
2. Setting Up	5	11. Privacy	15
2.1 Read the Safety Introductions	5	12. Apps	15
2.2 TV Stand and Wall Mounting	5	12.1 About Apps	15
2.3 Power Cable	5	12.2 Google Play	15
		12.3 Start or Stop an App	16
3. Remote Control	6	12.4 Manage Apps	16
3.1 Key Overview	6	13. System	17
3.2 Pair Your Remote Control to TV	7	13.1 Ambient Screensaver	17
3.3 Voice Search	7	13.2 Power & Energy	17
3.4 IR sensor	7	13.3 About	17
3.5 Batteries and Cleaning	8	13.4 Date & Time	18
4. Switching On and Off	8	13.5 Language	18
		13.6 Keyboard	18
5. Connect Devices	9	13.7 Storage	18
5.1 About Connections	9	13.8 Cast	18
5.2 Home Theatre System - HTS	9	13.9 System sounds	19
5.3 Digital Audio Out - Optical	10	13.10 Restart	19
5.4 Game Console/Video Camera	10	14. Accessibility	19
5.5 AV IN	10	15. Bluetooth®	20
5.6 Audio Out	10	16. Videos, Photos, Music	20
5.7 USB Flash Drive	10	17. Games	21
5.8 Connecting TV	11	17.1 Necessary preparations	21
5.9 Computer	11	17.2 Game controller	21
6. Connect your Google TV	11	18. Netflix	21
6.1 Network and Internet	11	19. TV Guide	21
6.2 Google Account	12	19.1 TV Guide Data	21
7. Sources	12	19.2 Open the TV Guide	21
8. Menu (TV)	13		
9. Channels	13		
9.1 Channel Scanning	13		
9.2 REC Option	13		
9.3 Time Shift Option	13		
9.4 Parental Controls	13		

20. Specifications	21
20.1 Environmental Protection	21
20.2 Power	22
20.3 Operating System	22
20.4 Display Type	22
20.5 TV Input Resolution	22
20.6 Connectivity	22
20.7 Sound	22
20.8 Multimedia	22
21. Help and Support	23
21.1 Troubleshooting	23
21.2 Online Help	24
21.3 Support and Repair	24
22. Safety and Care	24
22.1 Safety	24
22.2 Screen Care	25
23. Terms of Use	26
23.1 Terms of Use - TV	26
24. Copyrights	27
24.1 Google TV	27
24.2 HDMI	27
24.3 HEVC Advance	27
24.4 Dolby AUDIO	27
24.5 Other Trademarks	27
25. Disclaimer for services and/or software provided by third parties	27

# 1. Home Screen

---

## 1.1 Introduction

To enjoy the benefits of your Google TV, connect the TV to the Internet. Press **HOME** on your remote control to get your Home screen. Like on your Android smartphone or tablet, the Home screen is the centre of your TV. From the Home screen you can decide what to watch by browsing entertainment options from apps and live TV.

The Home screen is organized in rows to let you discover great contents from your favourite apps. Apps may populate their recommendation (if available) according to their own choice as an individual rows in the home screen.

### Highlights on your home screen

You can find movies and shows from services and popular apps using multiple index tabs, such as Search, Recommended for You, Videos, Shows, Apps, and Collections. Sign in to your Google account and let the streaming service provide you with personalized recommendations based on your past viewing content and interests. You can also trigger Google's search system using voice or text input in the Search Index tab.

### Favourite Apps

The home screen's application index includes all installed applications that come with the TV, as well as applications you have installed from the Google Play™ Store. You can also install and add more apps as Favorites from the Apps index tab.

### Tour guide

Decide what you want to watch next with easy-to-use navigation. Browse your personalized recommendations, pick up where you left off, or use the new index tag system to quickly find specific apps.

### Explore personalized recommendations

Browse your favorite shows and movies on all your favorite media services. Sign in to your Google Account to get started.

### Get recommendations through Google

Your services will be saved to your Google account, allowing you to get better recommendations across Google's services.

See also [www.support.google.com/googletv](http://www.support.google.com/googletv)

---

## 1.2 Dashboard and Settings

### Dashboard

The Dashboard is a side panel in your TV that provides access to settings, device controls, notifications, and more.

You can access the dashboard in three ways:

- 1 - Navigating to **Dashboard** icon in the home page.
- 2 - Press the **DASHBOARD** key on the remote control.
- 3 - Long press the **HOME** key on the remote control.

The dashboard contains the following features.

- **All Settings:** Access all settings menus to adjust TV settings.
- **Screensaver:** Display the system clock. Press this function to start the screen saver immediately.
- **Inputs:** Launch the input source list to switch to any connected device.
- **Display:** Quick links to adjust picture settings.
- **Sound:** Quick links to adjust sound settings.
- **Wi-Fi:** Quick links to adjust Wi-Fi settings.
- **Accessibility:** Quick links to adjust accessibility settings.
- **Bluetooth:** Quick links to adjust Bluetooth settings.
- **Notifications:** Provides you with TV system related.
- **Clear all:** Select **Clear all** to dismiss all notifications.

---

## 1.3 Open the home screen

To open the home screen and one of its items:

- 1 - Press **HOME**.
- 2 - Select an item and press OK to turn it on or start.
- 3 - Keep pressing **return** or press **HOME** to return to the home screen.

When opening the home screen, background application/content playback will stop. You must select the application or content from the home screen to continue.

## 2. Setting Up

### 2.1 Read the Safety Introductions

Read the safety instructions first before you use the TV.

### 2.2 TV Stand and Wall Mounting

#### TV Stand

You can find the instructions for mounting the TV stand in the Quick Start Guide that came with the TV. In case you lost this guide, you can download it from [www.philips.com/TVsupport](http://www.philips.com/TVsupport). Use the model number of the TV to look for the Quick Start Guide to download.

#### Wall Mounting

This television is sold without a wall mount. Please purchase a compatible mount separately for installation.

Wall mount dimensions may vary with different case types; see the Quick Start Guide included in the product packaging to see which sizes will fit your TV.

Please use the following dimensions when purchasing a wall mount.

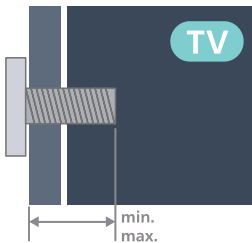

32"/43" 100x100mm

Upper: M4 (L: 9.5-10.5mm)

Lower: ST4 (L: 9.5-10.5mm)



M: Machine screw



ST: Flat tail self-tapping screw

#### Caution

Wall mounting the TV requires special skills and should only be performed by qualified personnel. The TV wall mounting should meet safety standards according to the TV's weight. Also read the safety precautions before positioning the TV. TP Vision Europe B.V. bears no responsibility for improper mounting or any mounting that results in accident or injury.

The wall-mounting hole pattern of this TV may differ from standard VESA configurations. Please verify that your chosen wall mount is compatible with the specific mounting pattern of this TV before installation.

### 2.3 Power Cable

- If the power cord is pluggable, insert the power cable into the POWER connector on the back of the TV.
- Make sure the power cable is securely inserted in the connector.
- Make sure that the power plug, in the wall socket, is accessible at all times.
- When you unplug the power cable, always pull the plug, never pull the cable.

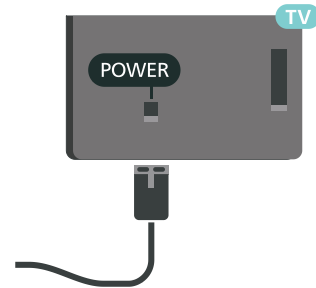

Although this TV has a very low standby power consumption, unplug the power cable to save energy if you do not use the TV for a long period of time.

# 3. Remote Control

## 3.1 Key Overview

### Top



- 1 - Power (Standby / On)  
To switch the TV on or back to Standby.
- 2 - VOICE microphone
- 3 - MENU
  - To open the TV Menu with typical TV functions.
  - In Multimedia mode, press to open/close the multimedia menu.
- 4 - prime video  
To launch the Amazon Prime Video App.
- 5 - **NETFLIX**
  - To launch the Netflix App with the TV switched on or from standby.
  - If you have a Netflix membership subscription, you can enjoy Netflix on this TV. Your TV must be connected to the Internet.
  - To open Netflix, press the NETFLIX key to open the **Netflix** App. You can open Netflix immediately from a TV in standby.
- 6 - (SOURCES)  
To open the Sources menu.
- 7 - YouTube  
To launch the YouTube App.
- 8 - Live TV  
To launch the Live TV App.
- 9 - (INFO)  
Press to open the programme information screen.
- 10 - (TV GUIDE)  
Electronic program guide.

### Middle

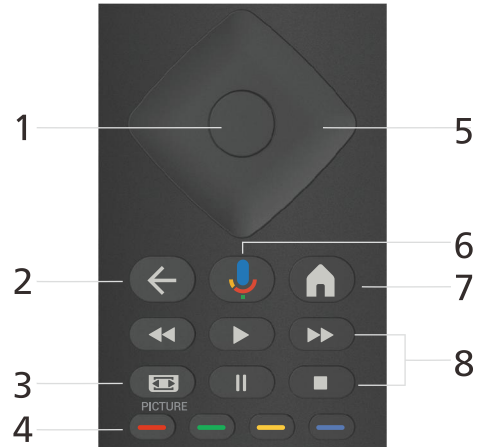

- 1 - OK key
  - To confirm a selection or setting.
  - Open/close the channel list menu.
- 2 - (Back)
  - Return to the previous menu.
  - Return to the previous application/internet page.
- 3 - (PICTURE)  
Open the Display menu.
- 4 - Colour keys  
Follow the on-screen instructions to select more options or operations.
- 5 - Navigation keys
  - In menu operations, press , , , to navigate up, down, left or right.
  - In TV mode, press , to select channel, press , to open the TV Menu with typical TV function.
- 6 - (Microphone/Google Assistant)  
Ask Google Assistant to find movies, stream apps, play music, control the TV and more - all with your voice.
- 7 - (Home)  
To open the Home menu. Long press to launch the Dashboard on side of screen.
- 8 - Playback
  - Play , to playback.
  - Pause , to pause.
  - Stop , to stop playback
  - Fast rewind , to rewind
  - Fast forward , to go fast forward

## Bottom

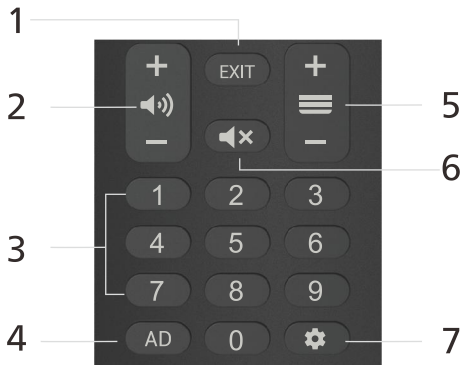

1- EXIT

To return to previous menu.

2- + (volume up) - Volume

Press + or - to adjust the volume level.

3- Number keys

To select a channel directly or enter numbers.

4- AD

To open audio menu.

5- + ≡ -

Change program channel.

6- Mute

Press to mute the sound or to restore it.

7- DASHBOARD

- To launch Dashboard on side of screen to access Settings, device controls, notifications and more.
- In TV mode, long press to open/close the virtual keyboard.

## 3.2 Pair Your Remote Control to TV

This remote control uses both Bluetooth® and IR (infrared) to send its commands to the TV.

- You can use this remote control via IR (infrared) for most operations.
- To use advanced operation like voice search and remote control keyboard, you need to pair (link) the TV with the remote control.

When you start the initial TV installation, the TV invites you to press **Home + Back** key to pair the remote control. It is suggested to complete the pairing during the first TV installation.

Note:

- 1 - Once the remote control has entered pairing mode successfully, the LED indicator ring around the microphone on the front side of the remote control starts blinking.
- 2 - The remote control must be kept close to the TV (within 1 m distance) during pairing in order to ensure success.
- 3 - If the TV does not launch the voice control field when you press **Voice**, pairing was unsuccessful.
- 4 - It is advisable to wait until the set has fully started up and launched all background processes before pairing mode is

entered as the toast message containing further instructions may appear too late, thereby negatively impacting the pairing procedure.

### Pairing again

If the pairing with the remote control was lost, you can pair the TV with the remote control again.

You can press **Home + Back** key (approximate for 3 seconds) for pairing. You can also go to **All settings > Remotes & Accessories > Pair accessory**, and then follow the on-screen instructions. A message will be displayed when the pairing is successful.

## 3.3 Voice Search

You can search for videos, music or anything else on the Internet by simply using your voice. You can speak into the microphone on the remote control.

You need to pair the remote control to the TV before use voice search.

To use Voice:

- 1 - Press **Voice** on remote control, the light on the remote control lights up and the search field opens, the microphone is active.
- 2 - Speak out what you are looking for with clear pronunciation. You can speak for 10 seconds before the microphone switches off. It might take some time for the results to appear.
- 3 - In the list of search results, you can select the item you want.

## 3.4 IR sensor

The TV can receive commands from a remote control that uses IR (infrared) to send commands. If you use such a remote control, always make sure you point the remote control at the infrared sensor on the front of the TV.

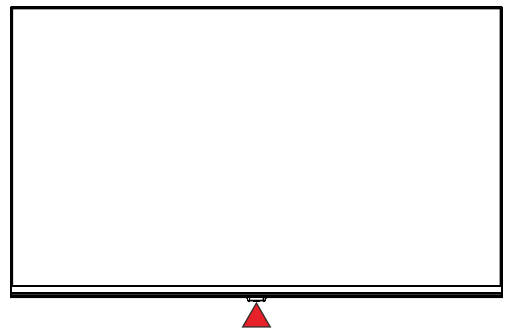

### Warning

Do not put any objects in front of IR sensor of the TV, it may block the IR signal.

---

## 3.5 Batteries and Cleaning

### Replace batteries

Refer to the **Quick Start Guide** in your product package for detailed information about the remote control batteries.

If the TV does not react on a key press on the remote control, the batteries might be empty.

To replace the batteries, open the battery compartment on the back of the remote control.

- 1 - Slide the battery door in the direction shown by the arrow.
  - 2 - Replace the old batteries with new batteries. Make sure the + and the - ends of the batteries line up correctly.
  - 3 - Reposition the battery door and slide it back until it clicks.
- Remove the batteries if you are not using the remote control for a long time.
  - Safely dispose of your old batteries according to the end of use directions.

### Cleaning

Your remote control is treated with a scratch-resistant coating. To clean the remote control, use a soft damp cloth. Never use substances such as alcohol, chemicals or household cleaners on the remote control.

---

## 4. Switching On and Off

Make sure the TV is connected to the mains AC power. The indicator light at the bottom of the TV lights up.

### Switch on

Press **Power** on the remote control to switch the TV on. You can also press the **⏻** key on the bottom of the TV to switch the TV on in case you can't find the remote control or its batteries are empty.

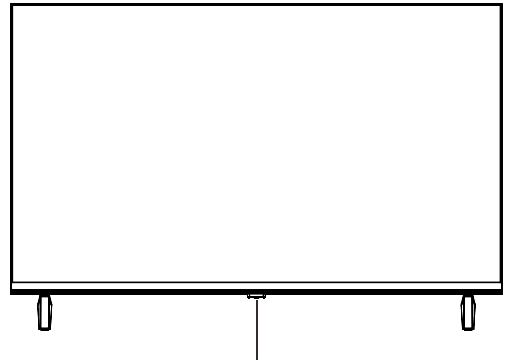

Power LED indicator and remote receiving window.

- ⏻** Standby: Turn the TV on or switch the TV back to standby. Long press to turn off the TV.

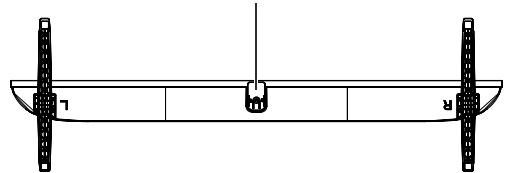

Appearance varies by model, please refer to the actual product. Please use the remote control for more operations.

A TV in standby mode remains connected to mains power, but consumes less power.

To turn off the TV completely, unplug the power plug.

When unplugging the power plug, be sure to pull up from the plug and never pull on the cable. Please ensure that the power plug, power cord and power socket of the product are easily accessible at all times.

# 5. Connect Devices

## 5.1 About Connections

This manual is shared by multiple models, the interface is slightly different, please refer to the actual.

### Connectivity Guide

Always connect a device to the TV with the highest quality connection available. Also, use good quality cables to ensure a good transfer of picture and sound.

When you connect a device, the TV recognizes its type and gives each device a correct type name. You can change the type name if you wish. If a correct type name for a device is set, the TV automatically switches to the ideal TV settings when you switch to this device in the Sources menu.

### Network port

Data input from the Internet.

LAN transmission rate:

Supports networks with speeds less than or equal to 100/10Mbps.

### HDMI ports

#### HDMI Quality

An HDMI connection has the best picture and sound quality. One HDMI cable combines video and audio signals. Use an HDMI cable for High Definition (HD) TV signals.

To transmit the best signal quality, please use ultra-high speed certified HDMI cables, and the HDMI cable length should not exceed 5 meters.

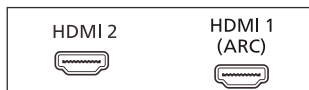

#### Anti-copy protection

HDCP (High-bandwidth Digital Content Protection) is a copy protection signal that prevents copying content from a DVD disc or Blu-ray Disc. Also referred to as DRM (Digital Rights Management).

#### HDMI ARC

Only **HDMI 1** supports **HDMI ARC** (Audio Return Channel) on the TV.

If the device, typically a Home Theatre System (HTS), sound bar or AV receiver, also has the HDMI ARC connection, connect it to HDMI 1 on this TV. With the HDMI ARC connection, you do not

need to connect the extra audio cable that sends the sound of the TV picture to the HTS. The HDMI ARC connection combines both signals.

You can use any HDMI connection on this TV to connect the HTS but ARC is only available for 1 device/connection at a time.



#### HDMI CEC

**All settings > Channels & Inputs > Inputs > Global CEC control.**

Connect an HDMI CEC-compatible device to the TV and operate it using the remote control.

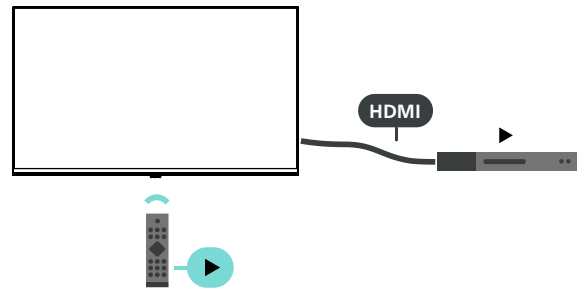

## 5.2 Home Theatre System - HTS

### Connect using HDMI ARC

Connect your home theater (HTS) to your TV using an HDMI cable. You can use the built-in CD player connected to a Philips Soundbar or HTS.

#### Home Theatre System

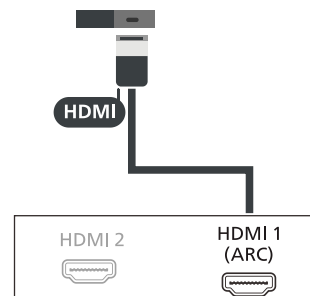

#### Audio and video synchronization (synchronization)

If the sound doesn't match the video on the screen, you can use a disc player to set a delay on most home theaters to synchronize the sound with the video.

---

## 5.3 Digital Audio Out - Optical

Audio Out - Optical is a high quality sound connection.

This optical connection can carry 5.1 audio channels. If your device, typically a Home Theatre System (HTS), has no HDMI ARC connection, you can use this connection with the Audio In - Optical connection on the HTS. The Audio Out - Optical connection sends the sound from the TV to the HTS.

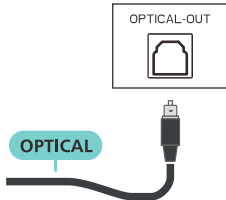

---

## 5.4 Game Console/Video Camera

For best signal quality transfer, use a High speed HDMI cable to connect your game console or camera on any one of HDMI connections.

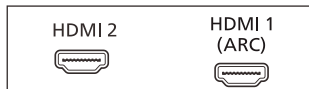

**HDMI**<sup>®</sup>  
HIGH-DEFINITION MULTIMEDIA INTERFACE



---

## 5.5 AV IN

It is used for audio and video transmission between the set-top box and the TV. The connection method is to use a dedicated AV cable.



- Ⓨ Yellow (video signal cable)
- Ⓦ White (audio left channel signal connection cable)
- Ⓡ Red (audio right channel signal connection cable)

---

## 5.6 Audio Out

Connect home audio devices.



---

## 5.7 USB Flash Drive

You can view photos or play your music and videos from a connected USB flash drive.

Insert a USB flash drive in one of the USB connections on the TV while the TV is switched on.

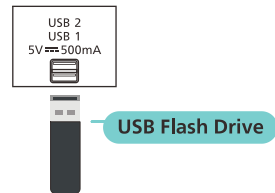

To view the files from the USB flash drive, press **Home** and select the **Your apps > MultiMediaPlayer** to start the app.

To stop watching the USB flash drive content, press **EXIT** or select another activity. Exit the **MultiMediaPlayer** app before you disconnect the flash drive.

To remove the USB flash drive safely:

- 1 - Go to **Settings > System > Storage**.
- 2 - Select your flash drive and press **OK**.
- 3 - Select **Eject** and press **OK**.
- 4 - Wait until the eject procedure is finished and then pull out the flash drive.

---

## 5.8 Connecting TV

### TV ANTENNA

RF (Radio Frequency or modulated signal design used as the carrier for television broadcasts.) input that connects to your Cable or VHF/UHF antenna.

#### Warning

When connecting outdoor antenna to signal port of the TV set, please turn off the main power switch of the TV set first. Do not approach the outdoor antenna to high voltage mains power line to avoid electric shock. The wired network antenna connected to this TV set must be isolated from the protective grounding, or else it will cause fire or other hazards.

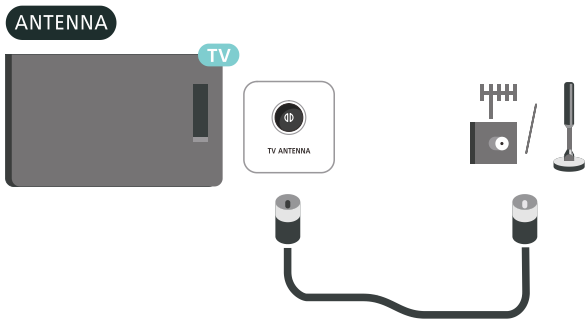

---

## 5.9 Computer

You can use a super-fast certified HDMI cable to connect your computer to the TV and use the TV as a computer TV.

\* Notes for AMD graphics card users:

If you are connecting your computer to your TV via HDMI, be sure to use the following graphics card settings for proper performance.

- If the video card output is 4096 x 2160p or 3840 x 2160p, and uses RGB pixel format, the computer display card should be set to RGB 4:4:4 pixel format Studio (limited RGB).

- If the display card output video is 2560 x 1440p 120Hz and uses RGB pixel format, the computer display card should be set to RGB 4:4:4 pixel format PC standard (full RGB).

---

## 6. Connect your Google TV

---

### 6.1 Network and Internet

#### Home Network

To enjoy the full capabilities of your Philips Google TV, your TV must be connected to the Internet.

Connect the TV to a home network with a high-speed Internet connection. You can connect your TV wirelessly or wired to your network router.

---

#### Connect to Network

---

##### Wireless Connection

##### What You Need

To connect the TV to the Internet wirelessly, you need a Wi-Fi router with a connection to the Internet.

Use a high-speed (broadband) connection to the Internet.

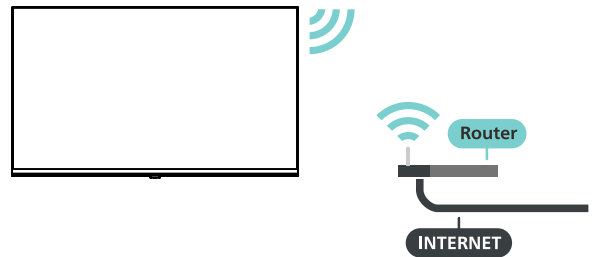

---

##### Turn Wi-Fi On or Off

- 1 - ⚙️ > ⚙️ **All settings** > **Network & Internet** > **Wi-Fi**.
- 2 - Press **OK** to turn on/off Wi-Fi

---

##### Make the Connection

⚙️ > ⚙️ **All settings** > **Network & Internet** > **Wi-Fi**.

- 1 - In the list of found networks, select on your wireless network. If your network is not in the list because the network name is hidden (you switched off the SSID broadcast of the router), select **Add new network** to enter the network name yourself.
- 2 - Follow the on-screen instruction.
- 3 - A message will be shown when the connection is successful.

---

##### Problems

##### Wireless network not found or distorted

- Microwave ovens, DECT phones or other Wi-Fi 802.11b/g/n/ac devices in your proximity might disturb the wireless network.
- Make sure that the firewalls in your network allow access to the TV's wireless connection.
- If the wireless network does not work properly In your home, try the wired network installation.

### Internet does not work

- If the connection to the router is OK, check the router connection to the Internet.

### The PC and Internet connection are slow

- Look in your wireless router's user manual for information on indoor range, transfer rate and other factors of signal quality.
- Use a high-speed (broadband) Internet connection for your router.

### DHCP

- If the connection fails, you can check the DHCP (Dynamic Host Configuration Protocol) setting of the router. DHCP should be switched on.

---

## Wired Connection

---

### What You Need

To connect the TV to the Internet, you need a network router with a connection to the Internet. Use a high-speed (broadband) connection to the Internet.

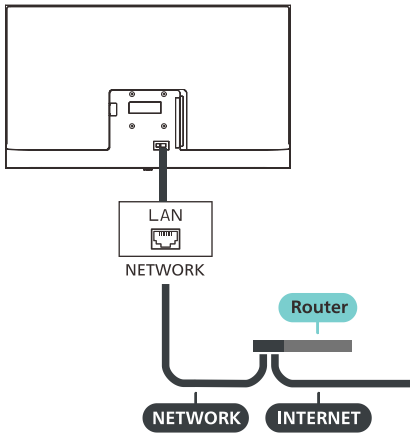

## Network and Internet settings

### View network settings

⚙️ > ⚙️ All settings > Network & Internet > IP settings > Static.

Here you can view all current network settings, IP address, gateway, network prefix length, DNS1, DNS2, etc.

### Wake On Network

Press ⚙️, and select ⚙️ All settings > System > Power & Energy > Energy Modes > Optimized, then press OK to set it to on or off.

Note: It is available when network is connected.

---

## 6.2 Google Account

### \*Note:

- 1 - This device requires you to log into your Google account to connect to the Internet.
- 2 - When scanning the code on your mobile to log into your Google account, your mobile and this device must be connected to the same WiFi network.
- 3 - If you do not wish to log into your Google account, you can select the option to skip the network connection step when turning on the device.

### Sign In Google Account

To enjoy the full capabilities of your Philips Google TV, you can sign in to Google with your Google Account.

By signing in you will be able to play your favourite games across phone, tablet and TV. You will also get customised video and music recommendations on your TV home screen as well as access to YouTube, Google Play and other apps.

### Sign In

Sign in to Google on your TV using your existing Google Account. A Google Account consists of an email address and a password. If you do not have a Google account yet, please create an account on your computer or tablet (accounts.google.com). If you are not logged in when you first install the TV, you can still log in at anytime.

To sign in after you did the TV installation:

- 1 - Press ⚙️, select ⚙️ All settings > Accounts & Profiles, then press OK.
- 2 - Select Add an account and press OK.
- 3 - Follow the on-screen prompts.
- 4 - With the on-screen keyboard, enter your email address and press OK.
- 5 - Enter your password and press OK to sign in.
- 6 - Press ⬅️ Back repeatedly if necessary, to close the menu.

---

## 7. Sources

### Switch to a Device

In the Input Source list, you can switch to any connected device. You can switch to a connected device to enjoy the program, such as a Blu-ray Disc player, etc.

To switch to a connected device:

- 1 - Press 📺 SOURCES to open the Sources menu.
- 2 - Select one of the item in the source list and press OK. The TV will show the programme or content of the device.

\*Note: HDMI devices listed as "Gray" in the "Inputs" list cannot be controlled using the TV remote control because the communication protocol is restricted.

# 8. Menu (TV)

---

## Menu operation description

Press **MENU** to show the main menu on the screen:

- 1 - Press **^ (up)** / **v (down)** to select a menu from **Channels, TV options, Record**.
- 2 - Press **< (left)** / **> (right)** to select an item in the menu.
- 3 - Press **OK** to enter the submenu.
- 4 - Press **^ (up)** / **v (down)** to adjust the value or setting.
- 5 - Press **← Back** to return to previous menu or exit the menu.
- 6 - During menu operation, the icons of invalid options are gray.



# 9. Channels

---



## 9.1 Channel Scanning

Scan the channels before watching the TV for the first time. Before scanning, please make sure that the antenna has been connected properly.



### Analog Scanning

After selecting **Live TV** source, press , and select  **All settings > Channels & Inputs > Channels > Analog > Channel Scan/Analog Manual Scan**, then press **OK** to enter. Operate as needed.

### Antenna Scanning

After selecting **Live TV** source, press , select  **All settings > Channels & Inputs > Channels > Antenna > Channel Scan**, then press **OK**, the machine starts auto scanning.



### Cable Scanning

After selecting **Live TV** source, press , select  **All settings > Channels & Inputs > Channels > Cable > Channel Scan > Scan**, then press **OK**, the machine starts auto scanning.

## 9.2 REC Option

Before recording, insert the USB mass storage device into the USB interface.

In DTV mode, press **MENU**, and select **Record > Device info > USB drive > Set PVR**, press **OK** to confirm.

Long press  to open the virtual keyboard. Select , then press **OK** to start recording. In the process of recording, press  to save and exit recording.

Press **MENU**, then select **Record > Record List**. Select the file that

you want to play, then press **OK** to play it.

While playing, press **OK** to stop playing. You can press **← Back** to exit playing, or press **▶/||/■/◀◀/▶▶** to perform shortcut operation.

*Note: Only the memorizer with FAT32 file system supports the recording function.*

## 9.3 Time Shift Option

In DTV mode, press **MENU**, and select **Record > Device info > USB drive > Set Timeshift**, press **OK** to confirm.

Press **MENU**, and select **Record > Time Shift Mode**, then press **OK** to turn on the timeshift function. Press **||** to start timeshifting.

When user pauses program for a short time, time-shift function can suspend and cache the playing program to U disk. When user resumes playing, the program can continue to be played.

In the process of the timeshift, Press  to stop and exit timeshift. you can press **▶/||/◀◀/▶▶** to perform shortcut operation.

## 9.4 Parental Controls

Press **MENU** key, and select **TV options > Parental Controls**, then press **OK** to enter. Then follow the prompts to operate.

- **Channels Blocked:** To prevent children from watching a channel, you can lock a channel. To watch a locked channel, you must enter the 4 digit PIN code first. You cannot lock programmes from connected devices.
- **Program Restrictions:** To prevent children from watching a programme that may not suitable for them, you can set a rating.
- **Tuner Inputs Blocked:** To prevent from using connected devices, you can lock an input source. To connect a **Tuner Input Blocked**, you must enter the 4 digit PIN code first.

# 10. Display & Sound

---

## 10.1 Display

### Display Settings

#### Picture Mode

  **All settings > Display & Sound > Display > Picture Mode.**

For easy picture adjustment, you can select a preset picture mode.

- **User** - Visual effects are adjusted according to individual preferences.
- **Standard** - Suited to everyday viewing of content such as TV programs, news and variety shows. Relatively even color and brightness make it perfect for watching for extended periods of

time.

- Vivid - Bright colors and high contrast make for an eye-catching image that is suited to watching animated shows, variety shows and adverts.
- Sport - Suited to watching fast-paced content such as sports matches and action movies.
- Movie - Suited to watching movies as they were originally intended to be viewed.
- Game - Suited to gaming.
- Energy Saving - The most energy-efficient setting.

---

## More Display Settings

### Backlight

⚙️ > ⚙️ All settings > Display & Sound > Display > Backlight.

Adjust the backlight level. The higher the backlight level, the clearer the image, which improves your movie-watching experience.

---

### Brightness

⚙️ > ⚙️ All settings > Display & Sound > Display > Brightness.

Adjust the brightness level to complement the room lighting.

---

### Contrast

⚙️ > ⚙️ All settings > Display & Sound > Display > Contrast.

Adjust the contrast level. Lowering the contrast level can help reduce power consumption as well as protect your eyesight.

---

### Saturation

⚙️ > ⚙️ All settings > Display & Sound > Display > Saturation.

Adjust the color saturation level.

---

### HUE

⚙️ > ⚙️ All settings > Display & Sound > Display > HUE.

Adjust the hue level. The lower the level, the cooler the hue. The higher the level, the warmer the hue. Adjust the level according to your preference.

---

### Sharpness

⚙️ > ⚙️ All settings > Display & Sound > Display > Sharpness.

Adjust the sharpness level.

---

### Advanced Settings

⚙️ > ⚙️ All settings > Display & Sound > Display > Advanced Settings.

Adjust more picture settings.

---

### Reset to Default

⚙️ > ⚙️ All settings > Display & Sound > Display > Reset to Default.

Restore default picture settings.

---

## 10.2 Screen

⚙️ > ⚙️ All settings > Display & Sound > Screen.

Adjust the aspect ratio.

Note: Some screen setting selections may not be available in some conditions. For example, in video streaming, Android app application, gaming mode, etc.

---

## 10.3 Sound

### Sound Settings

#### Sound Style

⚙️ > ⚙️ All settings > Display & Sound > Sound > Sound Style.

For easy sound adjustment, you can select a preset setting with sound style.

- User - Custom audio mode. This setting can only be used if the connected device is compatible with the TV and both support this feature.
- Standard - Suited to most programs as part of everyday viewing. Balanced and natural sound make it well suited for watching many kinds of content.
- Vivid - Ensures TV dialog is clear and easily comprehensible. Especially suited to movies or TV shows where loud background music drowns out the sound of people's voices.
- Sports - Suited to watching sports matches and programs.
- Movie - The perfect sound setting for watching movies.
- Music - The perfect sound setting for listening to music.
- News - Suited to speech-focused content such as news, interviews and lectures.

### More Sound Settings

⚙️ > ⚙️ All settings > Display & Sound > Sound.

- Basic settings
  - Balance
  - Bass
  - Treble
  - Surround Sound
  - Equalizer Detail
  - Auto Volume Control
- Speakers - Turn the TV speakers on or off.
- Speaker Delay - If you encounter the "Video and audio are out of sync" error when connected to an external Bluetooth speaker or a pair of wireless headphones, this feature lets you adjust the audio until it smoothly matches the video.
- Downmix Mode - Select Downmix mode: Stereo, Surround.
- Dialog Enhancer - Turning on **Dialog Enhancer** lets you separately increase vocal volume and clarity.
- Reset to Default - Restore default audio settings.

---

## 10.4 Audio Output

⚙️ > ⚙️ All settings > Display & Sound > Audio Output.

- Digital Output - Switch digital output mode.
- Audio Output Device - Switch audio output device mode.
- Digital Output Delay - Set digital output delay.

---

## 11. Privacy

⚙️ > ⚙️ All settings > Privacy.

View and adjust your Smart TV's privacy settings.

- Location
- Microphone
- Camera
- Usage & diagnostics
- Ads
- Voice assistant
- Payment & Purchases
- Manage Updates
- App permissions
- Special app access
- Security

---

## 12. Apps

---

### 12.1 About Apps

You can find your favorite Apps on **Your apps** row in the Home menu.

Like apps on your smartphone or tablet, the apps on your TV offer specific functions for an enriched TV experience. You can use the **WEB BROWSER** app to surf the Internet.

Apps can come from the Google Play™ Store. To get you started, some practical apps are pre-installed on your TV.

To install apps from the Google Play™ Store, the TV must be connected to the Internet. You must sign in with a Google Account to use the Google Play apps and Google Play™ Store. Select the app you want to install and select **Install** button to start the installation. Once the app installation is done, you can select **Open** button to open the app, or **Uninstall** button to uninstall the app.

---

## 12.2 Google Play

### Movies and TV

With **Google TV** app, you can rent or buy movies and TV shows to watch on TV.

#### What You Need

- your TV must be connected with the Internet.
- you must sign in with your Google Account on TV.
- add a credit card to your Google Account to purchase movies and TV shows.

#### To rent or buy a movie or TV show:

- 1 - Press **HOME** and select **Apps** tab.
- 2 - Select **Google TV** app and open it.
- 3 - Select a movie or TV show and press **OK**.
- 4 - Select the purchase you want and press **OK**. You will be taken through the purchase procedure.

#### To watch a rented or bought movie or TV show:

- 1 - Press **HOME** and select **Apps** tab.
- 2 - Select **Google TV** app and open it.
- 3 - Select the movie or TV show from your library in the app, select the title and press **OK**.
- 4 - You can use the **Stop, Pause, Rewind** or **Fast forward** keys on the remote control.
- 5 - To stop the Movies & TV app, press **← Back** repeatedly or press **EXIT**.

\* Note: If **Google TV** is not on **Your Apps** row, you can search it in search field to **Open** or **Install** it.

Find more information on [www.support.google.com/googletv](http://www.support.google.com/googletv)

### Music

With **YouTube Music**, you can play your favourite music on TV. You can buy new music on your computer or mobile device. Or, on your TV, you can sign up for All Access, the Google Play Music subscription. Alternatively, you can play the music you already own, stored on your Computer.

#### What You Need

- your TV must be connected with the Internet.
- you must sign in with your Google Account on TV.
- add a credit card to your Google Account to take a music subscription.

#### To start YouTube Music:

- 1 - Press **HOME** and select **Apps** tab.
- 2 - Select **YouTube Music** app and open it.
- 3 - Select the music you want and press **OK**.
- 4 - To stop the Music app, press **← Back** repeatedly or press **EXIT**.

\* Note: If **YouTube Music** is not on **Your Apps** row, you can search it in search field to **Open** or **Install** it.

Find more information on  
[www.support.google.com/googletv](http://www.support.google.com/googletv)  
or [support.google.com/youtubemusic](http://support.google.com/youtubemusic)

## Games

With Google Play Games, you can play games on TV. Online or offline.



You can see what your friends are playing currently or you can join the game and compete. You can track your achievements or start wherever you left off.

### What You Need

- your TV must be connected with the Internet.
- you must sign in with your Google Account on TV.
- add a credit card to your Google Account to purchase new games

Start the Google Play Games app to select and install new game apps on your TV. Some games are free of charge. A message appears if a particular game needs a gamepad to play the game.

### To start or stop a Google Play Game:

- 1 - Press  **HOME** and select **Apps** tab.
- 2 - Select **Google Play Games** app and open it.
- 3 - Select a game to play or select a new game to install and press **OK**.
- 4 - When done, press  **Back** repeatedly or press **EXIT** or stop the app with its dedicated exit/stop button.

\* Note: If **Google Play Games** is not on **Your Apps** row, you can search it in search field to **Open** or **Install** it.

Find more information on  
[www.support.google.com/googletv](http://www.support.google.com/googletv)



## Google Play Store

From the Google Play Store you can download and install new apps. Some apps are free of charge.

### What You Need

- your TV must be connected with the Internet.
- you must sign in with your Google Account on TV.
- add a credit card to your Google Account to purchase Apps.



### To install a new app:

- 1 - Press  **HOME** and select **Apps** tab.
- 2 - Select **Google Play Store** app and open it.
- 3 - Select the app you want to install and press **OK**.
- 4 - To close the **Google Play Store**, press  **Back** repeatedly or press **EXIT**.

### Parental controls

In the Google Play Store, you can hide apps according to users/buyers maturity. You need to enter a PIN code to select or change the level of maturity.

### To set the parental control:

- 1 - Press  **HOME** and select **Apps** tab.
- 2 - Select **Google Play Store** app and open it.
- 3 - Select **Google Account > Settings > Parental controls**.
- 4 - Select the level of maturity you want.
- 5 - On request, enter the PIN code.
- 6 - To close the **Google Play Store**, press  **Back** repeatedly or press **EXIT**.

\* Note: If **Google Play Store** is not on **Your Apps** row, you can search it in search field to **Open** or **Install** it.

Find more information on  
[www.support.google.com/googletv](http://www.support.google.com/googletv)

## Payments

To make a payment on Google Play on TV, you must add a form of payment - a credit card (outside the United States) - to your Google Account. When you purchase a movie or TV show, you will be charged on this credit card.

### To add a credit card:





- 1 - On your computer, go to [accounts.google.com](http://accounts.google.com) and sign in with the Google Account you will use with Google Play on TV.
- 2 - Go to [wallet.google.com](http://wallet.google.com) to add a card to your Google Account.
- 3 - Enter your credit card data and accept the terms and conditions.

---

## 12.3 Start or Stop an App

You can start an app from the Home screen.

### To start an app:

- 1 - Press  **HOME**.
- 2 - Move to **Your apps** row, select the app you want and press **OK**.
- 3 - You can also search the app in search field to **Open** or **Install** it.
- 4 - Alternately, you can go to  **>**  **All Settings > Apps > See all apps** or **Show system apps** to select an app to open.
- 5 - To stop an app, press  **Back** or press **EXIT** or stop the app with its dedicated exit/stop button.

---

## 12.4 Manage Apps

### **>** **All Settings > Apps.**

If you stop an app and return to the Home menu, the app is not really stopped. The app is still running in the background to be readily available when you start it again. To run fluently, most apps need to save some data in the cache memory of the TV. It might be good to stop an app completely or clear the cache data of a particular app to optimise the overall performance of apps and to keep memory usage low on your TV. Also, it is best

to uninstall apps that you are not using anymore. You can select **Apps > See all apps** or **Unused apps** to list your installed or used apps.

For each installed app, you can also set the permissions for **Manage Updates, App permissions, Special app access** and **Security**.

Find more information on  
[www.support.google.com/googletv](http://www.support.google.com/googletv)

## 13. System

---

### 13.1 Ambient Screensaver

#### Settings for Ambient screensaver

⚙️ > ⚙️ **All settings > System > Ambient Screensaver.**

Ambient screensaver is the screen saver to avoid displaying still images for a longer period of time. You can set the photo source, display weather or time information, adjust the speed of slideshow.

### 13.2 Power & Energy

---

#### Energy Modes

⚙️ > ⚙️ **All settings > System > Power & Energy > Energy Modes.**

- Low - Set it so that the network turns off when the TV is in standby mode.
- Optimized - Set it so that the network remains connected when the TV is in standby mode.
- Increased - Set it so that the network remains connected at all times.

#### Shut-Off Timer

⚙️ > ⚙️ **All settings > System > Power & Energy > Shut-Off Timer.**

Set the time to turn off TV display automatically to save energy.

- When inactive - Automatically turn off when inactive.
- When watching - Set it so that the TV automatically shuts down after a certain amount of time passes when watching video content.
- Countdown from now - Set it so that the TV automatically shuts down after a certain amount of time passes starting from now.

#### Power on behavior

⚙️ > ⚙️ **All settings > System > Power & Energy > Power on behavior.**

Set the TV stay on **Google TV home screen** or on **Last used input** when power on the TV.

#### Scheduled power on/off

⚙️ > ⚙️ **All settings > System > Power & Energy > Scheduled power on/off.**

Set it so that the TV automatically shuts down or turns on after a certain amount of time.

---

## 13.3 About

### System Software Update

---

#### Update from Internet

If the TV is connected to the Internet, you may receive a message to update the TV software. You need a high-speed (broadband) Internet connection. If you receive this message, we recommend you to carry out the update.

With the message on screen, select **Update** and follow the instructions on-screen.

You can also look for a software update yourself.

During the software update, there is no picture and the TV will switch off and on again. This might happen several times. The update can take a few minutes. Wait until the TV picture comes back up. Do not press the power switch  on the TV or on the remote control during the software update.

To look for a software update yourself:

- 1 - ⚙️ > ⚙️ **All settings > System > About > System update** and press **OK**.
- 2 - The TV will look for an update on the Internet.
- 3 - If an update is available, you can update the software right away.
- 4 - A software update can take several minutes. Do not press the  key on the TV or remote control.
- 5 - When the update is done, the TV will return to the channel you were watching.

---

#### Device name

⚙️ > ⚙️ **All settings > System > About > Device name.**

View the TV's device name.

---

#### Reset

⚙️ > ⚙️ **All settings > System > About > Reset > Factory reset.**

Reset all settings to factory settings.

---

#### Status

Display TV status information

⚙️ > ⚙️ **All settings > System > About > Status.**

To display the TV status about IP address, Device MAC address, Bluetooth address, Serial number, etc.

---

## System Information

1 - > All settings > System > About > Model, Android TV OS version, Android TV OS security patch level, Kernel version, Android TV OS build, Netflix ESN, Software Version.

2 - The version, release notes and creation date are shown. Also, the Netflix ESN Number and other information are shown if available.

3 - Press < (left) repeatedly if necessary, to close the menu.

---

## 13.4 Date & Time

> All settings > System > Date & Time.

### Automatic date & time

> All settings > System > Date & Time > Automatic date & time.

Set to use **network-provided time** or **Off** to use system time.

### Set date

> All settings > System > Date & Time > Set date.

Set current date.

### Set time

> All settings > System > Date & Time > Set time.

Set current time.

### Set time zone

> All settings > System > Date & Time > Set time zone.

Set current time zone.

### Use 24-hour format

> All settings > System > Date & Time > Use 24-hour format.

Set to use 24-hour format to display the time.

---

## 13.5 Language

Change the language of the TV menu and messages.

> All settings > System > Language.

Select the language to display TV menu and messages.

---

## 13.6 Keyboard

Settings for the connected keyboard and virtual keyboards.

> All settings > System > Keyboard.

Connect the USB keyboard to one of the USB connections on this TV. When the TV detects the keyboard for the first time, you can select your keyboard lay-out and test your selection. You can also manage the settings of connected keyboard and virtual keyboards.

## Open Source Licenses

> All settings > System > Keyboard > Gboard Settings > Open source licenses.

### About Open Source License

README for the source code of the parts of TP Vision Europe B.V. TV software that fall under open source licenses.

This is a document describing the distribution of the source code used on the TP Vision Europe B.V. TV, which fall either under the GNU General Public License (the GPL), or the GNU Lesser General Public License (the LGPL), or any other open source license.

Instructions to obtain copies of this software can be found in the Directions For Use.

TP Vision Europe B.V. MAKES NO WARRANTIES WHATSOEVER, EITHER EXPRESS OR IMPLIED, INCLUDING ANY WARRANTIES OF MERCHANTABILITY OR FITNESS FOR A PARTICULAR PURPOSE, REGARDING THIS SOFTWARE. TP Vision Europe B.V. offers no support for this software. The preceding does not affect your warranties and statutory rights regarding any TP Vision Europe B.V. product(s) you purchased. It only applies to this source code made available to you.

---

## 13.7 Storage

### Internal shared storage

You can see how much storage space - the internal TV memory - you are using for your apps, videos, music, etc. You can see how much free space you still have available for installing new apps. Check your storage if apps start to run slow or in case of app trouble.

> All settings > System > Storage > Internal shared storage.

See how much storage you are using.

### Free up storage

> All settings > System > Storage > Free up storage.

- Clear cache.
- Uninstall apps

---

## 13.8 Cast

> All settings > System > Cast.

### What You Need

If an app on your mobile device has Google Cast, you can cast your app on this TV. On the mobile app, look for the Google Cast icon. You can use your mobile device to control what's on TV. Google Cast works on Android and iOS.

\* Note: The Google Cast functionality works only in Google TV Mode and not in Basic TV mode.

Your mobile device must be connected to the same Wi-Fi home

network as your TV.

### Apps with Google Cast

New Google Cast apps come available every day. You can already try it with YouTube, Chrome, Netflix, Photowall... or Big Web Quiz for Chromecast. See also [google.com/cast](http://google.com/cast)

Some Google Play products and features aren't available in all countries.

Find more information on [www.support.google.com/googletv](http://www.support.google.com/googletv)

## Cast to Your TV

To cast an app to the TV screen:

- 1 - On your smartphone or tablet, open an app that supports Google Cast.
- 2 - Tap the Google Cast icon.
- 3 - Select the TV you would like to cast to.
- 4 - Press play on your smartphone or tablet. What you selected should start playing on TV.

---

## 13.9 System sounds

Settings for system sound

⚙️ > ⚙️ All settings > System > System sounds.

Enable or disable the system sounds.

---

## 13.10 Restart

⚙️ > ⚙️ All settings > System > Restart.

**Note:**

- Disconnect the external USB hard disc before rebooting.
- Wait for few seconds, the TV restart automatically.

This will remove unnecessary data and information in the memory.

If your TV runs low performance when using Apps, such as the video and audio are not synchronised or the App is running slow, reboot your TV for better performance.

# 14. Accessibility

---

⚙️ > ⚙️ All settings > Accessibility.

With **Accessibility** switched on, the TV is prepared for use for the deaf, hard of hearing, blind or partially sighted people.

### Talkback (Screen reader)

⚙️ > ⚙️ All settings > Accessibility > Talkback (Screen reader)

Assists visually impaired users by reading aloud on-screen text, menu items and other elements.

### Text to speech

⚙️ > ⚙️ All settings > Accessibility > Text to speech.

Set to convert the text into speech for blind or partially sighted people.

### Text scaling

⚙️ > ⚙️ All settings > Accessibility > Text scaling.

Adjust subtitle text size.

### Bold text

⚙️ > ⚙️ All settings > Accessibility > Bold text.

Turn bold text on or off.

### Color correction

⚙️ > ⚙️ All settings > Accessibility > Color correction.

It can help those with color-related vision difficulties (such as colorblind people) to better recognize or distinguish colors through adjustments to colors on screen.

### Accessibility shortcut

⚙️ > ⚙️ All settings > Accessibility > Accessibility shortcut.

Quick access to Accessibility settings.

### Time to take action (accessibility timeout)

⚙️ > ⚙️ All settings > Accessibility > Time to take action (accessibility timeout).

Adjust duration of messages that require action.

### Key repeat delay

⚙️ > ⚙️ All settings > Accessibility > Key repeat delay.

Adjust the delay before key repeat.

### Audio description

⚙️ > ⚙️ All settings > Accessibility > Audio description.

Hear a description of what's happening on screen in supported movies and shows.

### High contrast text

⚙️ > ⚙️ All settings > Accessibility > High contrast text.

Turn on to make texts displayed with higher contrast for easier reading.

# 15. Bluetooth®

## Bluetooth® On or Off

### Pairing accessories

The Bluetooth® device should be located within 5 meters of the TV. Read the device's user manual for information on pairing and wireless range of the device. Please make sure the Bluetooth® setting on the TV is turned on.

Once you pair a Bluetooth® device, you can select it to play your TV's sound. Once pairing is complete, there is no need to re-pair the device unless you remove it.

To pair a Bluetooth® device with the TV:

- 1 - Turn on the power of the Bluetooth® device and place the device within the signal range of the TV.
- 2 - Press **⚙️**, then select **⚙️ All Settings > Remotes & Accessories > Pair accessory**.
- 3 - Follow the on-screen instructions.

This will pair the device with the TV and the TV will save the connection. If the maximum number of paired devices has been reached, you may need to unpair the paired devices first.

- 4 - If necessary, press **⬅️ Back** repeatedly to return to the previous level.

### Device Operation

To rename a Bluetooth® device:

- 1 - Select **⚙️ All settings > Remotes & Accessories > ACCESSORIES**.
- 2 - In the list, select a Bluetooth® device.
- 3 - Select **Rename** to rename a Bluetooth® device.
- 4 - Press **⬅️** (left) repeatedly if necessary, to close the menu.

To remove Bluetooth® device:

- 1 - Select **⚙️ All settings > Remotes & Accessories > ACCESSORIES**.
- 2 - In the list, select a Bluetooth® device.
- 3 - Select **Forget** to remove the Bluetooth® device.
- 4 - Press **⬅️** (left) repeatedly if necessary, to close the menu.

To view the information of Bluetooth® device:

- 1 - Select **⚙️ All settings > Remotes & Accessories > ACCESSORIES**.
- 2 - In the list, select a Bluetooth® device.
- 3 - The information of Bluetooth® device is listed on the bottom.
- 4 - Press **⬅️** (left) repeatedly if necessary, to close the menu.

# 16. Videos, Photos, Music

You can view your photos or play your music and videos from a connected USB flash drive.

With the TV switched on, plug in a USB flash drive to one of the USB connections.

- 1 - Press **🏠 Home**, select **Your apps > MultiMediaPlayer** from the Apps list and press **OK**.
- 2 - Use Navigation keys to select the file type.
- 3 - Follow the on-screen instructions to play the files.

Notice:

- 1 - Some non-standard USB devices may not be recognized, please replace them with standard USB devices;
- 2 - The streaming media system has certain restrictions on the format of each playback file. If the system limit is exceeded, the playback will fail;
- 3 - Please do not plug or unplug USB devices during system playback, as this may cause system or device problems. Before replacing the USB device, please disconnect the power of the machine first;
- 4 - The USB 1 and USB 2 interface support standard USB1.1 and USB2.0 devices, such as USB mass storage devices and mobile hard disks;
- 5 - The maximum output current of the USB 1 and USB 2 interface of this device is 500mA. When the limit is exceeded, the machine will self-protect. If the user connects an external device with a relatively large current, it is recommended to use an external power supply;
- 6 - The local system is very complex, equivalent to a computer system, so when reading or playing files, due to factors such as USB device compatibility and stability, the screen may stop or the function may not work. Please try Shut down the machine and reinitialize the system.

While playing, press **MENU** key to display the menu options, select the corresponding menu, and press **OK** key to confirm the operation. Users can press **EXIT** key to exit playback, or press **▶/||/■/◀◀/▶▶** keys to perform shortcut operations

# 17. Games

---

## 17.1 Necessary preparations

Games that can be played on this TV include:

- Google Play Store from main menu
- From a connected console

Games from the Google Play Store need to be downloaded and installed on the TV before they can be played. Some games require a game controller to play.

To install a game app from the Google Play Store, your TV must be connected to the Internet and you must agree to the Terms of Use to use the app. You must log in with a Google account to use Google Play apps and the Google Play store.

## 17.2 Game controller

To play online games on this TV, you can connect a select range of wireless game controllers. This TV can support the connection of 2 game controllers at the same time. Once you connect your game controller, it's ready to use right away.

# 18. Netflix

---

If you have a Netflix membership subscription, you can enjoy Netflix on this TV. Your TV must be connected to the Internet. In your region, Netflix might only come available with future software updates.

To open Netflix, press **NETFLIX** on the remote control to open the Netflix App. You can open Netflix immediately from a TV in standby.

[www.netflix.com](http://www.netflix.com)

# 19. TV Guide

---

## 19.1 TV Guide Data

With the TV Guide you can view a list of the current and scheduled TV programmes of your channels. Depending on where the TV guide information (data) is coming from, analogue and digital channels or only digital channels are shown. Not all channels offer TV Guide information. The TV can collect TV Guide information for the channels that are installed on the TV. The TV cannot collect the TV Guide information from channels viewed

## 19.2 Open the TV Guide

To open the TV Guide, press **TV GUIDE**. The TV Guide shows the channels of the selected tuner.

Press **TV GUIDE** again to close.

The first time you open the TV Guide, the TV scans all TV channels for programme information. This may take several minutes. TV Guide data is stored on TV.

# 20. Specifications

---

## 20.1 Environmental Protection

### Product card

32"

- Visible screen size: 80 cm/ 32 inches
- Power consumption in power-on mode (W): 55 W
- Standby power consumption (W)\*\*:  $\leq 0.5$  W
- Display resolution (pixels): 1366 x 768p

43"

- Visible screen size: 108 cm/ 43 inches
- Power consumption in power-on mode (W): 75 W
- Standby power consumption (W)\*\*:  $\leq 0.5$  W
- Display resolution (pixels): 1920 x 1080p

\*\*When the TV is turned off using the remote control and no functions are activated. Power consumption in full standby mode is  $\leq 0.5$  W.

It takes several minutes for the TV to enter full standby mode.

Note: If you turn on **Wake On Network** function, the maximum power consumption of the machine in standby mode does not exceed 1W.

### Product end of use

#### Disposal of used products and batteries

Please take the initiative to learn about the different recycling and disposal systems for electronic and electrical products in your local area.

Please follow local regulations and do not throw away old products with general household waste. Proper disposal of old products helps avoid potential adverse effects on the environment and human health.

Please take the initiative to learn about your local regulations regarding battery recycling, as proper disposal can help avoid adverse effects on the environment and human health.

---

## 20.2 Power

Product specifications are subject to change without notice. For more specification details of this product, see [www.philips.com/TVsupport](http://www.philips.com/TVsupport).

Power

- Mains power: 100-240V~
- Ambient temperature: 5°C to 35°C

---

## 20.3 Operating System

Android OS

---

## 20.4 Display Type

Display resolution

32":

- 1366 x 768

43":

- 1920 x 1080

---

## 20.5 TV Input Resolution

### HDMI Mode

#### Supported Computer resolution

Resolution — Refresh rate

32":

- 720 x 400 - 70Hz
- 640 x 480 - 60Hz
- 800 x 600 - 60Hz
- 1024 x 768 - 60Hz
- 1360 x 768 - 60Hz

43":

- 640 x 480 - 60Hz
- 800 x 600 - 60Hz
- 1024 x 768 - 60Hz
- 1280 x 1024 - 60Hz
- 1600 x 900 - 60Hz
- 1920x 1080 - 60Hz

#### Supported Video resolution

Resolution — Refresh rate

32"/43":

- 720 x 480i/p - 60Hz
- 720 x 576i/p - 50Hz
- 1280 x 720p - 50Hz, 60Hz
- 1920 x 1080i/p - 50Hz, 60Hz

---

## 20.6 Connectivity

TV Side

- USB 1/USB 2: USB 2.0
- Audio output
- Digital Audio out: Optical out
- HDMI 1 in: ARC
- HDMI 2 in
- Network LAN: RJ45
- TV ANTENNA
- AV IN

---

## 20.7 Sound

Output power (RMS): 32": 6W+6W  
43": 8W+8W

- Dolby Audio

---

## 20.8 Multimedia

Connections

- USB 2.0
- Ethernet LAN RJ-45
- Wi-Fi 802.11 a/b/g/n/ac
- Bluetooth® 5.1

Supported USB file systems

- FAT32, NTFS

Playback formats

- Video Codecs: MPEG1/2, VC1, AVC/H.264, HEVC/H.265, VVC/H.263, AV1, VP8
- Audio Codecs: MPEG1/2 Layer2, MPEG1/2/2.5 Layer3, AC3, EAC3, HEAAC
- Image Codecs: JPEG, PNG, BMP, GIF
- Subtitles formats support: SRT, SSA, ASS, SMI, SUB, TXT

# 21. Help and Support

---

## 21.1 Troubleshooting

### Switch On and Remote Control

#### The TV does not switch on

- Disconnect the power cable from the power outlet. Wait for one minute then reconnect it.
- Make sure that the power cable is securely connected.

#### Creaking sound at startup or switch off

When you are switching the TV on, off or to standby, you hear a creaking sound from the TV chassis. The creaking sound is due to the normal expansion and contraction of the TV as it cools and warms up. This does not affect performance.

#### TV does not respond to the remote control

The TV requires some time to start up. During this time, the TV does not respond to the remote control or TV controls. This is normal behaviour.

If the TV continues to be unresponsive to the remote control, you can check if the remote control is working by means of a mobile phone camera. Put the phone in camera mode and point the remote control to the camera lens. If you press any key on the remote control and you notice the infra-red LED flicker through the camera, the remote control is working. The TV needs to be checked.

If you do not notice the flickering, the remote control might be broken or its batteries are low.

This method of checking the remote control is not possible with remote controls which are wirelessly paired with the TV.

#### The standby light keeps flashing

Please unplug the power cord from the electrical outlet. Wait 5 minutes before reconnecting the power cord. If flickering still occurs, please contact Philips TV Customer Care Center.

### Picture

#### No picture/distorted picture

- Please make sure you select the correct device as the TV input source.
- Please confirm that the external device or input source is connected correctly.

#### There is sound but no picture

- Change to another video source, then switch back to the current source, then restore the picture style in the "Display" settings.

#### The picture quality transmitted by the device is poor

- Make sure the device is connected correctly. If applicable, make sure the device's output video is set to the highest resolution.

#### Image does not fit the screen size

- Please change to another aspect ratio.
- Change the aspect ratio to original.

#### The screen position is incorrect

- The picture signal sent by some devices may not match the screen size. Please check the signal output of the connected device.
- Change the aspect ratio to automatic.

#### Computer screen is unstable

Please make sure your computer uses a supported resolution and update/refresh rate.

### Sound

#### No sound or poor sound quality

If no audio signal is detected, the TV automatically switches the audio output off — this does not indicate malfunction.

- Make sure that the sound settings are correctly set.
- Make sure that all cables are properly connected.
- Make sure that the volume is not muted or set to zero.
- Make sure that the TV audio output is connected to the audio input on the Home Theatre System.

Sound should be heard from the HTS speakers.

- Some devices may require you to manually enable HDMI audio output. If HDMI audio is already enabled, but you still do not hear audio, try changing the digital audio format of the device to PCM (Pulse Code Modulation). Refer to the documentation accompanying your device for instructions.

### Network

#### Wi-Fi network not found or distorted

- Microwave ovens, DECT phones or other Wi-Fi 802.11b/g/n/ac devices in your proximity might disturb the wireless network.
- Make sure that the firewalls in your network allow access to the TV's wireless connection.
- If the wireless network does not work properly in your home, try the wired network installation.

#### Internet does not work

- If the connection to the router is OK, check the router connection to the Internet.

#### The PC and Internet connection are slow

- If the connection fails, you can check the DHCP (Dynamic Host Configuration Protocol) setting of the router. DHCP should be switched on.

---

## 21.2 Online Help

Go to [www.philips.com/TVsupport](http://www.philips.com/TVsupport) to solve any Philips TV related problem, you can consult our online support. You can select your language and enter your product model number. On the support site you can find your country's telephone number to contact us as well as answers to frequently asked questions (FAQs). In some countries, you can chat with one of our collaborators and ask your question directly or send a question by email.

---

## 21.3 Support and Repair

For support and repair, call the Consumer Care hotline in your country. Our service engineers will take care of a repair, if necessary.

Find the telephone number in the printed documentation that came with the TV.

Or consult our website [www.philips.com/TVsupport](http://www.philips.com/TVsupport) and select your country if needed.

### TV model number and serial number

You might be asked to provide the TV product model number and serial number. Find these numbers on the packaging label or on the type label on the back or bottom of the TV.

### Warning

Do not attempt to repair the TV yourself. This may cause severe injury, irreparable damage to your TV or void your warranty.

---

# 22. Safety and Care

---

## 22.1 Safety

### Important

Read and understand all safety instructions before you use the TV. If damage is caused by failure to follow instructions, the warranty does not apply.

### Risk of Electric Shock or Fire

- Never expose the TV to rain or water. Never place liquid containers, such as vases, near the TV. If liquids are spilt on or into the TV, disconnect the TV from the power outlet immediately. Contact Philips TV Consumer Care to have the TV checked before use.
- Never expose the TV, remote control or batteries to excessive heat. Never place them near burning candles, naked flames or other heat sources, including direct sunlight.
- Never insert objects into the ventilation slots or other openings on the TV.
- Never place heavy objects on the power cord.
- Avoid force coming onto power plugs. Loose power plugs can cause arcing or fire. Ensure that no strain is exerted on the power cord when you swivel the TV screen.
- To disconnect the TV from the mains power, the power plug of the TV must be disconnected. When disconnecting the power, always pull the power plug, never the cord. Ensure that you have full access to the power plug, power cord and outlet socket at all times.

### Risk of Injury or Damage to the TV

- Two people are required to lift and carry a TV that weighs more than 25 kg or 55 lbs.
- If you mount the TV on a stand, only use the supplied stand. Secure the stand to the TV tightly. Place the TV on a flat, level surface that can support the weight of the TV and the stand.
- When wall mounted, ensure that the wall mount can safely bear the weight of the TV set. TP Vision bears no responsibility for improper wall mounting that results in accident, injury or damage.
- Parts of this product are made of glass. Handle with care to avoid injury or damage.

Risk of damage to the TV !

Before you connect the TV to the power outlet, ensure that the power voltage matches the value printed on the back of the TV. Never connect the TV to the power outlet if the voltage is different.

## Stability Hazards

This product is designed and intended for consumers and personal use in a domestic home environment, unless agreed otherwise with the manufacturer in writing. Failure to follow this recommendation or the instructions provided in the product user manual and the product supportive documentation can cause damage to the product and will void the warranty for such cases. A television set may fall, causing serious personal injury or death. Many injuries, particularly to children, can be avoided by taking simple precautions such as:

- ALWAYS ensure the television set is not overhanging the edge of the supporting furniture.
- ALWAYS use cabinets or stands or mounting methods recommended by the manufacturer of the television set.
- ALWAYS use furniture that can safely support the television set.
- ALWAYS educate children about the dangers of climbing on furniture to reach the television set or its controls.
- ALWAYS route cords and cables connected to your television so they cannot be tripped over, pulled or grabbed.
- NEVER place a television set in an unstable location.
- NEVER place the television set on tall furniture (for example, cupboards or bookcases) without anchoring both the furniture and the television set to a suitable support.
- NEVER place the television set on cloth or other materials that may be located between the television set and supporting furniture.
- NEVER place items that might tempt children to climb, such as toys and remote controls, on the top of the television or furniture on which the television is placed.

If the existing television set is going to be retained and relocated, the same considerations as above should be applied.

## Risk of Batteries

- Do not ingest the battery. Chemical burn hazard.
- The remote control may contain a coin/button cell battery. If the coin/button cell battery is swallowed, it can cause severe internal burns in just 2 hours and can lead to death.
- Keep new and used batteries away from children.
- If the battery compartment does not close securely, stop using the product and keep it away from children.
- If you think batteries might have been swallowed or placed inside any part of the body, seek immediate medical attention.
- Risk of fire or explosion if the battery is replaced by an incorrect type.
- Replacement of a battery with an incorrect type that can defeat a safeguard (for example, in the case of some lithium battery types).
- Disposal of a battery into fire or a hot oven, or mechanically crushing or cutting of a battery, that can result in an explosion.
- Leaving a battery in an extremely high temperature surrounding environment that can result in an explosion or the leakage of flammable liquid or gas.
- A battery subjected to extremely low air pressure that may result in an explosion or the leakage of flammable liquid or gas.

## Risk of Overheating

Never install the TV in a confined space. Always leave a space of at least 10 cm or 4 inches around the TV for ventilation. Ensure curtains or other objects never cover the ventilation slots on the TV.

## Lightning Storms

Disconnect the TV from the power outlet and antenna before lightning storms. During lightning storms, never touch any part of the TV, power cord or antenna cable.

## Risk of Hearing Damage

Avoid using earphones or headphones at high volumes or for prolonged periods of time.

## Low Temperatures

If the TV is transported in temperatures below 5°C or 41°F, unpack the TV and wait until the TV temperature reaches room temperature before connecting the TV to the power outlet.

## Humidity

In rare occasions, depending on temperature and humidity, minor condensation can occur on the inside of the TV glass front (on some models). To prevent this, do not expose the TV to direct sunlight, heat or extreme humidity. If condensation occurs, it will disappear spontaneously while the TV is playing for a few hours. The condensation moisture will not harm the TV or cause malfunction.

---

## 22.2 Screen Care

- Never touch, push, rub or strike the screen with any object.
- Unplug the TV before cleaning.
- Clean the TV and frame with a soft damp cloth and wipe gently. Never use substances such as alcohol, chemicals or household cleaners on the TV.
- To avoid deformations and colour fading, wipe off water drops as quickly as possible.
- Avoid stationary images as much as possible. Stationary images are images that remain onscreen for extended periods of time. Stationary images include onscreen menus, black bars, time displays, etc. If you must use stationary images, reduce screen contrast and brightness to avoid screen damage.

# 23. Terms of Use

---

## 23.1 Terms of Use - TV

2026 © TP Vision Europe B.V. All rights reserved.

This product was brought to the market by TP Vision Europe B.V. or one of its affiliates, hereinafter referred to as TP Vision, which is the manufacturer of the product. TP Vision is the warrantor in relation to the TV with which this booklet was packaged. Philips and the Philips Shield Emblem are registered trademarks of Koninklijke Philips N.V.

Specifications are subject to change without notice. Trademarks are the property of Koninklijke Philips N.V or their respective owners. TP Vision reserves the right to change products at any time without being obliged to adjust earlier supplies accordingly.

The written material packaged with the TV and the manual stored in the memory of the TV or down loaded from the Philips website [www.philips.com/TVsupport](http://www.philips.com/TVsupport) are believed to be adequate for the intended use of the system.

The material in this manual is believed adequate for the intended use of the system. If the product, or its individual modules or procedures, are used for purposes other than those specified herein, confirmation of their validity and suitability must be obtained. TP Vision warrants that the material itself does not infringe any United States patents. No further warranty is expressed or implied. TP Vision cannot be held responsible neither for any errors in the content of this document nor for any problems as a result of the content in this document.

Errors reported to Philips will be adapted and published on the Philips support website as soon as possible.

Terms of warranty - Risk of injury, damage to TV or void of warranty!

Never attempt to repair the TV yourself. Use the TV and accessories only as intended by the manufacturer. The caution sign printed on the back of the TV indicates risk of electric shock. Never remove the TV cover. Always contact Philips TV Customer Care for service or repairs. Find the telephone number in the printed documentation that came with the TV. Or consult our website [www.philips.com/TVsupport](http://www.philips.com/TVsupport) and select your country if needed. Any operation expressly prohibited in this manual, or any adjustments and assembly procedures not recommended or authorised in this manual, shall void the warranty.

Pixel characteristics

This TV product has a high number of colour pixels. Although it has effective pixels of 99.999% or more, black dots or bright points of light (red, green or blue) may appear constantly on the screen. This is a structural property of the display (within common industry standards) and is not a malfunction. Therefore, please note this is not subjected to repair, exchange or refund within and/or out of the warranty period.

Backlight characteristics

All Philips TV have gone through stringent tests and checks before shipping to you. You can be rest assured that we place the quality of our TVs the utmost Importance so that you do not suffer any viewing displeasure while watching your TV. However, please note that backlight bleeding ("Mura effect") and /or unevenness of background light that can only be observed in dark images or in a very dark and dim room are considered to be within TV specifications. Such occurrences do not represent a deterioration nor shall be regarded as a defect of the TV. Hence, we regret that claims of this nature for warranty, free of charge service, replacement or refund cannot be accepted within and/or out of the warranty period.

TP Vision is committed to developing, producing and marketing products that cause no adverse health effects. TP Vision confirms that, as long as its products are handled properly for their intended use, they are safe to use according to scientific evidence available today. TP Vision plays an active role in the development of international safety standards, enabling TP Vision to anticipate further developments in standardisation for early integration in its products.

## 24. Copyrights

---

### 24.1 Google TV

Google TV is the name of this device's software experience and a trademark of Google LLC.

Google, YouTube and other marks are trademarks of Google LLC.



---

### 24.2 HDMI

The terms HDMI, HDMI High-Definition Multimedia Interface, HDMI Trade dress and the HDMI Logos are trademarks or registered trademarks of HDMI Licensing Administrator, Inc.



---

### 24.3 HEVC Advance

Covered by one or more claims of the HEVC patents listed at [patentlist.accessadvance.com](http://patentlist.accessadvance.com).

Future proof with advanced HEVC decoding



---

### 24.4 Dolby AUDIO

Manufactured under license from Dolby Laboratories. Dolby, Dolby Audio, and the double-D symbol are registered trademarks of Dolby Laboratories Licensing Corporation.



---

### 24.5 Other Trademarks

All other registered and unregistered trademarks are the property of their respective owners.

## 25. Disclaimer for services and/or software provided by third parties

---

Services and/or software offered by third parties may be changed, suspended, or terminated without prior notice. TP Vision does not bear any responsibility in these sorts of situations.

