

PHILIPS

Whitepaper

Image quality and speed at your fingertips

Philips SmartSpeed No compromise

Authors:

Authored by: Hans Peeters PhD, Hayley Chung PhD, Giuseppe Valvano PhD, Deniz Yakisikli MSc., Jeroen van Gemert PhD, Elwin de Weerdt PhD and Kim van de Ven PhD.

All authors are Philips employees

Step into the future with confidence

Executive summary

As the clinical utility of MRI has increased, so has the pressure to efficiently scan more patients than ever. Declining reimbursements and increased backlog are making productivity and decreasing cost per scan more important than ever.

The need for speed and robustness

A reduction of scan and examination times addresses these needs to a large extent. The most straightforward way to decrease examination times is to reduce the scan times of the individual protocols. On top of that, a significant productivity increase can be achieved by minimizing the amount of rescans and reexaminations, as up to 20% of sequences need to be repeated due to motion artifacts¹.

Reduction of motion artifacts and image quality degradations can also have a positive effect on reading times by radiologists while decreasing the reading errors and increasing diagnostic confidence. On top of that, from a patient and technologist perspective there

is a big impact when scan and examination times are shortened. Shorter scan times can minimize wait times and reduce patient stress due to physical discomfort² while for technologists it can reduce the overtime or increase interaction time with patients.

Philips SmartSpeed is addressing these needs by taking the next step in scan acceleration while preserving diagnostic confidence and providing robustness for all routine protocols. The improved image quality originates not only from a scan time reduction, but also from intrinsic sequence design for challenging conditions to which the SmartSpeed acceleration technology is applied.



Philips SmartSpeed: the next generation in acceleration

Philips SmartSpeed builds upon Philips' track record in acceleration techniques. It brings it to the next level by expanding the proven Compressed SENSE technology, broadening its scope to previously untouched imaging protocols and by enhancing

the image reconstruction with AI algorithms applied early in the reconstruction process. It delivers MRI methods that allow improvements to address multiple needs.



Productivity

By speeding up the scan time almost 3 times*, Philips SmartSpeed can increase MRI department productivity and reduce cost per exam.



Diagnostic confidence

By providing up to 65% more resolution*, Philips SmartSpeed delivers outstanding image quality to enable radiologists to confidently provide information to the referring physician.



Patient accessibility

Designed for a broad range of patients regardless of their condition with **97% applicability** to provide fast first-time right imaging.

Philips SmartSpeed leverages a modular framework that expands and improves Compressed SENSE into multiple application areas and anatomical domains:

- **Philips SmartSpeed AI** integrates deep learning technology early in the reconstruction pipeline to accelerate all commonly used sequences in all application domains. This can be flexibly leveraged to increase productivity by speeding up exams as well as to improve diagnostic confidence because of the increased resolution that can be achieved.
- **Philips SmartSpeed MotionFree** provides motion-robust multi-slice scanning for all image contrasts across multiple anatomies with similar or shorter exam times compare to the current on-motion compensated equivalent.
- **Philips SmartSpeed 3D FreeBreathing** reduces the scan time of free breathing 3DT1w scans, allowing first-time-right scanning after contrast injections.
- **Philips Philips SmartSpeed Implant** enables imaging around metallic implants as fast as regular MSK imaging without compromising on image quality.
- **Philips SmartSpeed Diffusion** accelerates diffusion-weighted imaging and improves diagnostic quality by a reduction of g-factor related noise.

Philips SmartSpeed: Building on Philips' legacy in SENSE and Compressed SENSE

How have Philips' acceleration technologies helped to reduce scan and exam times over the past two decades?

Over the last two decades, Philips has been introducing and improving acceleration techniques. It started with the introduction of SENSE in 1999 and continued with additions to the SENSE family with dS SENSE³, MultiBand SENSE and Compressed SENSE⁴ (Figure 1).

Compressed SENSE is still the most versatile compressed sensing-based solution in the industry today, delivering high-resolution images for all 2D and 3D scans in all anatomies and all image contrasts in minimum scan time.

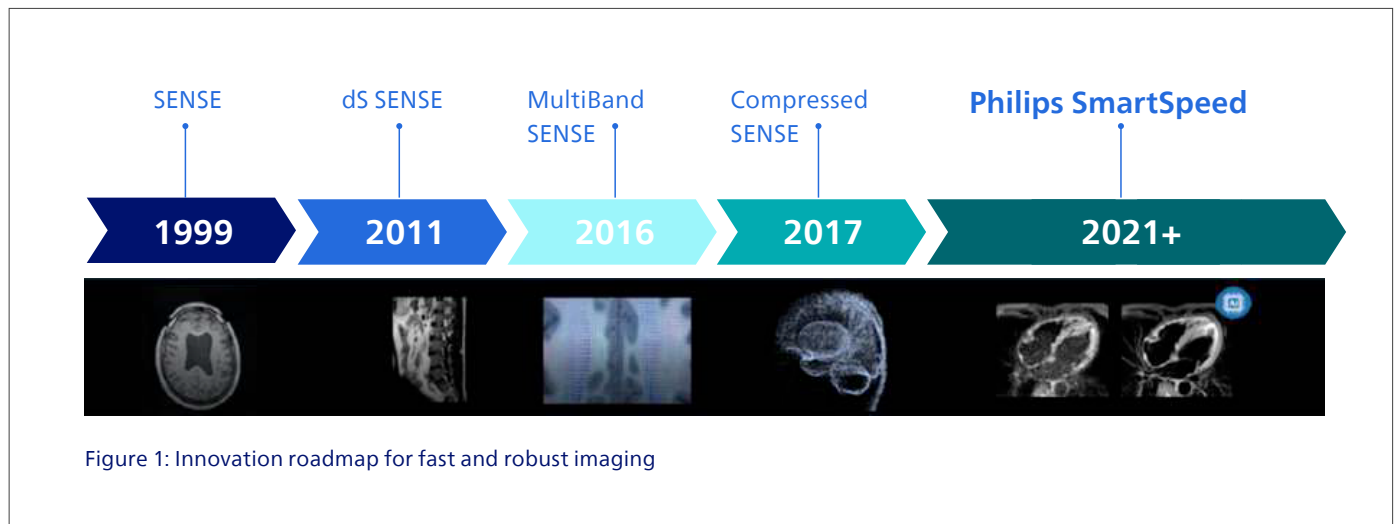

Figure 1: Innovation roadmap for fast and robust imaging

What kind of clinical and productivity enhancements can be expected of Philips SmartSpeed?

To understand the impact Philips SmartSpeed can bring to clinical practice, we start with the proven value of Compressed SENSE, which has been available since early 2018, and implemented globally. Compressed SENSE allows for productivity enhancement by reducing the scan times of individual acquisitions by up to 50%* and of full exams by 20-30%*.

Today, more than 60% of new MR sales include Compressed SENSE**. A considerable number of peer reviewed scientific research studies prove the value of Compressed SENSE to decrease scan times of individual sequence⁵, complete examinations⁶, quantitative imaging^{7,8,9,10} and its application in post-contrast scans^{11,12,13}.

These studies demonstrate the versatility of the technology and the fact that it can be easily applied on a large range of anatomical areas ranging from head to toe, as well as a large range of different 2D and 3D image contrasts.

The Philips SmartSpeed acceleration engine further builds on the strengths of its predecessors while expanding the versatility. It extends the application range to accommodate imaging in challenging situations related to motion, implants and low SNR in diffusion. On top of that, further speed improvements are realized by incorporating deep learning in the Philips SmartSpeed framework. The key ingredients of this modular framework are explained in Figure 2.

*Compared to conventional parallel imaging (SENSE)

** as of 2021

Philips SmartSpeed is the next step in the Philips unique coil combination framework, leveraging the strengths introduced with SENSE (coil sensitivity and background information) and Compressed SENSE (sparsity constraint)⁵. It is a modular framework with two key ingredients to accelerate image acquisition:

- Acquisition of less data using dedicated data sampling patterns.
- Smart reconstruction technology that allows the image quality from such a limited amount of data to be regained.

Under-sampling the amount of data acquired in k-space is limited in the SENSE algorithms by the number of coil elements and their geometrical positioning. Compressed SENSE has overcome this problem by the introduction of the sparsity constraint. With the transformation to the wavelet domain and an iterative reconstruction, it is possible to sample even less data while maintaining or even improving the high image quality standard.

This is achieved with a variable density under-sampling pattern that is designed specifically for this new reconstruction method. The reconstruction algorithms and computational platform are designed and engineered such that they are fast and efficient, to avoid that the time gained during scanning is lost while generating the images.

The Philips SmartSpeed Engine is a modular framework that incorporates existing strengths and in-depth knowledge of the MR system design and expands this with new technologies. It is enriched by performing sparsity constraining with a connected set of convolution neural networks for 2D and 3D Cartesian acquisitions. Furthermore, the wavelet-based sparsity constraint reconstruction is extended with EPI diffusion, implant imaging (O-MAR XD) and non-Cartesian read-out techniques (radial and MultiVane XD).

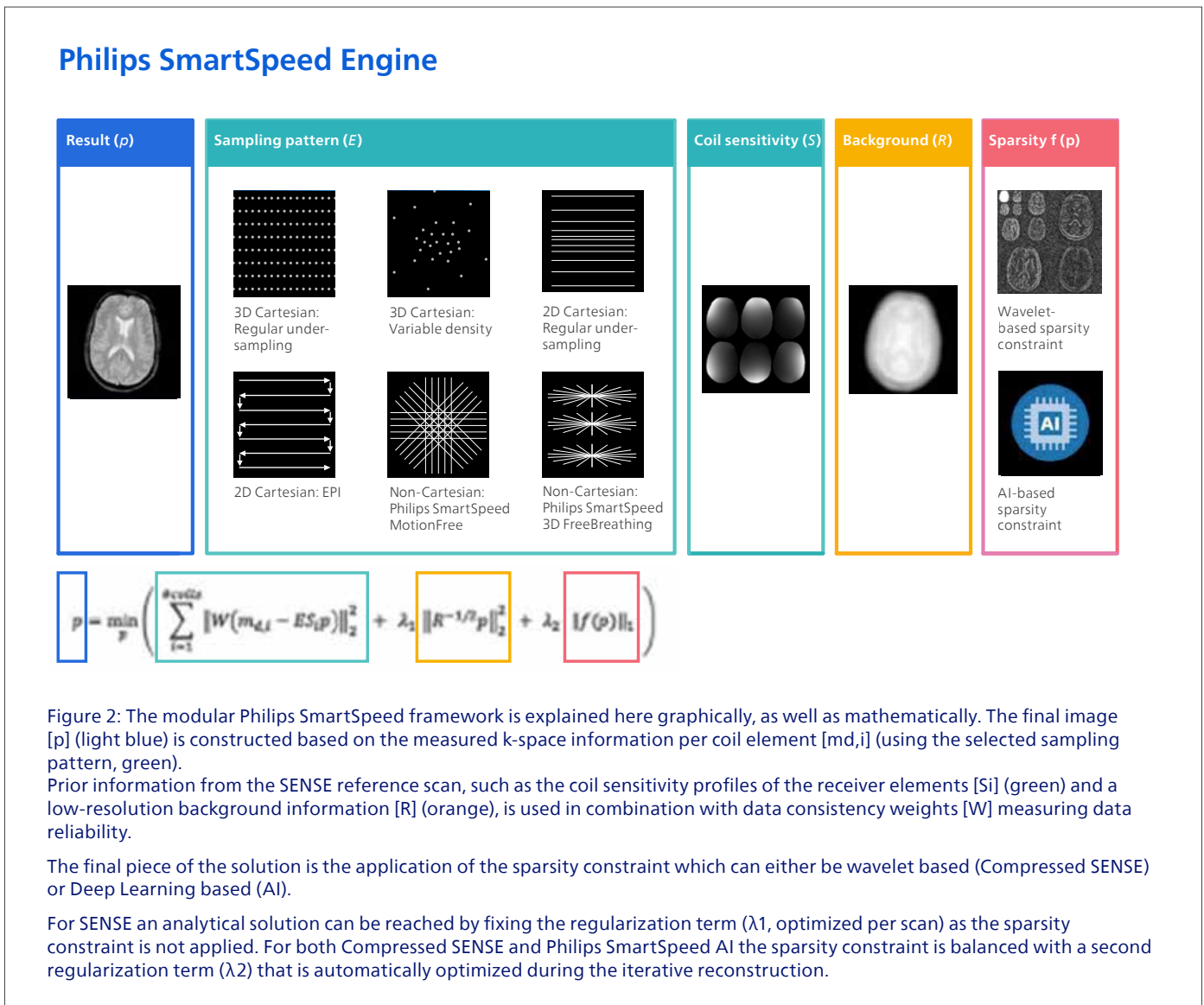

Philips SmartSpeed AI: unparalleled acceleration

Philips SmartSpeed AI evolved from its SENSE and Compressed SENSE ancestors by integrating deep learning methods into a proven acceleration framework of optimized sampling paradigms, multi-coil element input, and an iterative reconstruction with sparsity constraining. With the integration of the AI technology in the coil element combination step of the reconstruction, the maximum amount of information available after signals are acquired is leveraged.

With this approach, Philips SmartSpeed AI supersedes the current industry norm, where deep learning technology is applied on complex imaging data or as a post-processing step. In this section, the benefits of integrating deep learning during coil element combination are explained as well as the type of convolution neural network that is used. The clinical benefits of faster and higher resolution imaging are shown for multiple application areas.

What is deep learning and where does it fit in the AI picture?

Artificial intelligence (AI) is defined as the science devoted to making machines think and act like humans. Computers are designed to perform structured tasks and excel in applying rules, but it is clear that many human actions cannot be realized by computers. AI can augment the expertise of healthcare professionals and support their decision-making, improve operational efficiency to free up focus on patient care, and empower people to take better care of their health and well-being¹⁴.

Machine learning (ML), a specific area within AI research, and deep learning (DL), a specific area within machine learning, are techniques able to analyze large sets of data and act on it. ML is categorized as letting computers perform tasks without explicit programming. DL is the subset of ML algorithms based on deep neural networks of which convolutional neural networks (CNNs) are a specific class. Deep neural networks are inspired by animal and human neural networks and consist of connected artificial neurons in multiple layers between input and output.

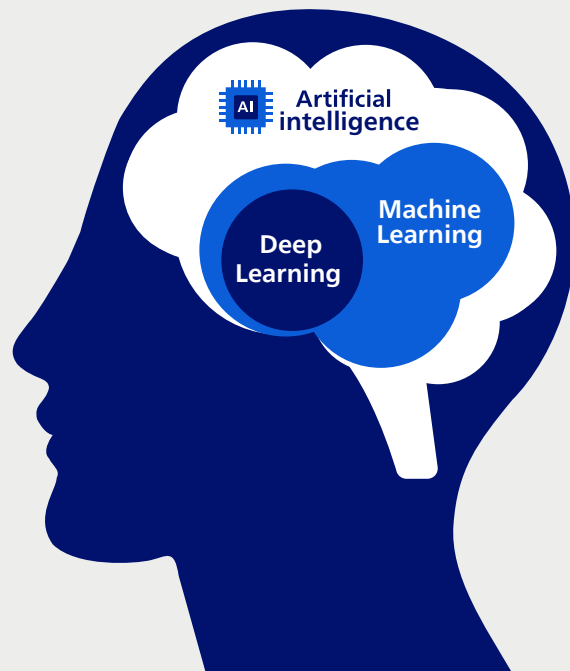

Figure 3: Schematic representation of areas covering artificial intelligence

How can deep learning be integrated into the MR imaging chain?

Deep learning can be applied at multiple locations within the MR imaging chain (Fig. 4) ranging from calculating the sampling strategy and reconstructing the raw data, to post-processing of the images.

Many deep learning applications are in the postprocessing domain, for example denoising, filtering and segmentation. Also, the reconstruction pipeline is extremely suited to apply deep learning, as image reconstruction is generally a sequence of different operations. Therefore, we first take a step back by reviewing the conventional reconstruction pipeline in Fig. 4. Raw k-space data enters the reconstruction, after which Fourier transforms are applied. In the channel combination step the (under-sampled) data from all individual coil elements are combined into a single complex valued image. The image generation phase contains steps including the magnitude operation, digitization for storage, phase contrast operations.

As indicated earlier in this paper, the imaging chain consists of several steps, deep learning can be applied to many of these. However, every step will inevitably lead to a loss of information. The effectiveness of the deep learning algorithms depends on the goal and the location it is applied to:

- 1 Deep learning during post-processing:** AI applied at the end of the chain on the DICOM data has the advantage that it can be implemented as an additional post-processing step on any system having access to the images. However, information removed in the earlier steps of the reconstruction, e.g. phase information, is lost and can no longer be used.
- 2 Deep learning during image generation:** AI algorithms that are applied to the complex imaging data do use the phase information, and allow iteration between the AI processed imaging data and the k-space data that is generated by the inverse Fourier transform of the coil element combined image. However, the disadvantage of AI during image generation is that the raw k-space data of the individual elements cannot be used in the optimization, for example to check data consistency in the iterative reconstruction.
- 3 Deep learning during the channel combination:** In Philips SmartSpeed AI, deep learning is applied during the coil element combination part of the reconstruction chain. In its most basic view, the sparsity constraining step of the iterative reconstruction in Philips SmartSpeed AI is deep learning based. The applied convolutional neural network is trained for all contrasts and a wide range of acceleration factors, and outperforms conventional general sparsifying representations such as the wavelet transformation that is implemented in Compressed SENSE. This ensures the highest data consistency and signal fidelity.

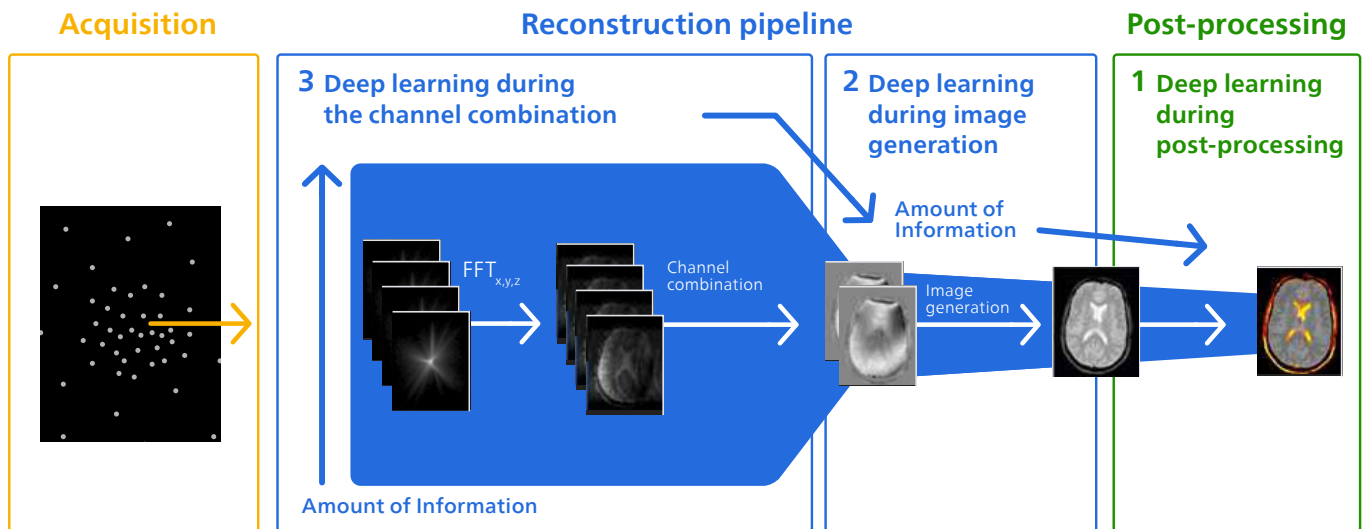

Figure 4: Graphical representation of the MR imaging chain with a detailed view on the reconstruction pipeline. The imaging chain starts with the acquisition process in which the sampling strategy is defined. Raw k-space data enters the reconstruction pipeline to generate DICOM images. During the post-processing phase, different operations like additional filtering or segmentation can be performed. In the reconstruction pipeline raw k-space data of several coil elements enters the reconstruction and is Fourier transformed, resulting in an image per coil element. In the channel combination step, the individual coil element images are combined into a single complex valued image. During the subsequent image generation step, DICOM images are produced by e.g. modulus operations (addition, subtraction), phase contrast calculations or mDixon water-fat separation. The light blue area indicates how during each step the amount of data reduces; a lot of the information of the original multi-element input data is condensed, resulting in reduced information that can be used by the convolution neural network applied. Therefore, the Philips SmartSpeed AI algorithm is applied at the channel combination step to leverage the maximum available information.

What neural network topology is implemented in Philips SmartSpeed AI?

The convolutional neural network topology implemented in Philips SmartSpeed AI is the Adaptive-CS-Net^{15,16}. Figure 5 provides a graphical representation of this implementation. The Adaptive-CS-Net model was first explored for the fastMRI knee challenge organized by New York Langone Health and Facebook AI Research. In this challenge, it was scored best by a panel of seven independent readers on a set of knee MR images¹⁷. Compared to the challenge implementation, for the Philips SmartSpeed AI the network training is expanded to a much larger set of data to accommodate different imaging contrasts and different anatomical regions to make sure all application domains and contrasts are covered for Cartesian 2D and 3D scans. The Adaptive-CS-Net is applied early in the reconstruction chain to make use of all the available data of individual coil elements as well as to be able to incorporate prior knowledge into the algorithm. For example, coil sensitivities are available to the algorithm, as well as regularization

with respect to the anatomical area is performed. This information can be incorporated in the deep learning network itself, but it has two main drawbacks: (1) the size of the network will become too large to be deployed with acceptable reconstruction times and (2) generalization over all application domains, contrasts and coil topologies will become impractical. This will affect the trustworthiness of the algorithm to reconstruct true image content.

Similar to Compressed SENSE, each individual unique block in the Adaptive-CS-Net chain is fed by the incoming raw k-space data for data consistency checking to ensure trustworthy output images. In the fastMRI challenge, all finalists used this aspect of data consistency checking with the incoming raw data as part of their method, demonstrating the importance of leveraging the data early in the reconstruction chain compared to techniques that rely solely on the reconstructed images¹⁸.

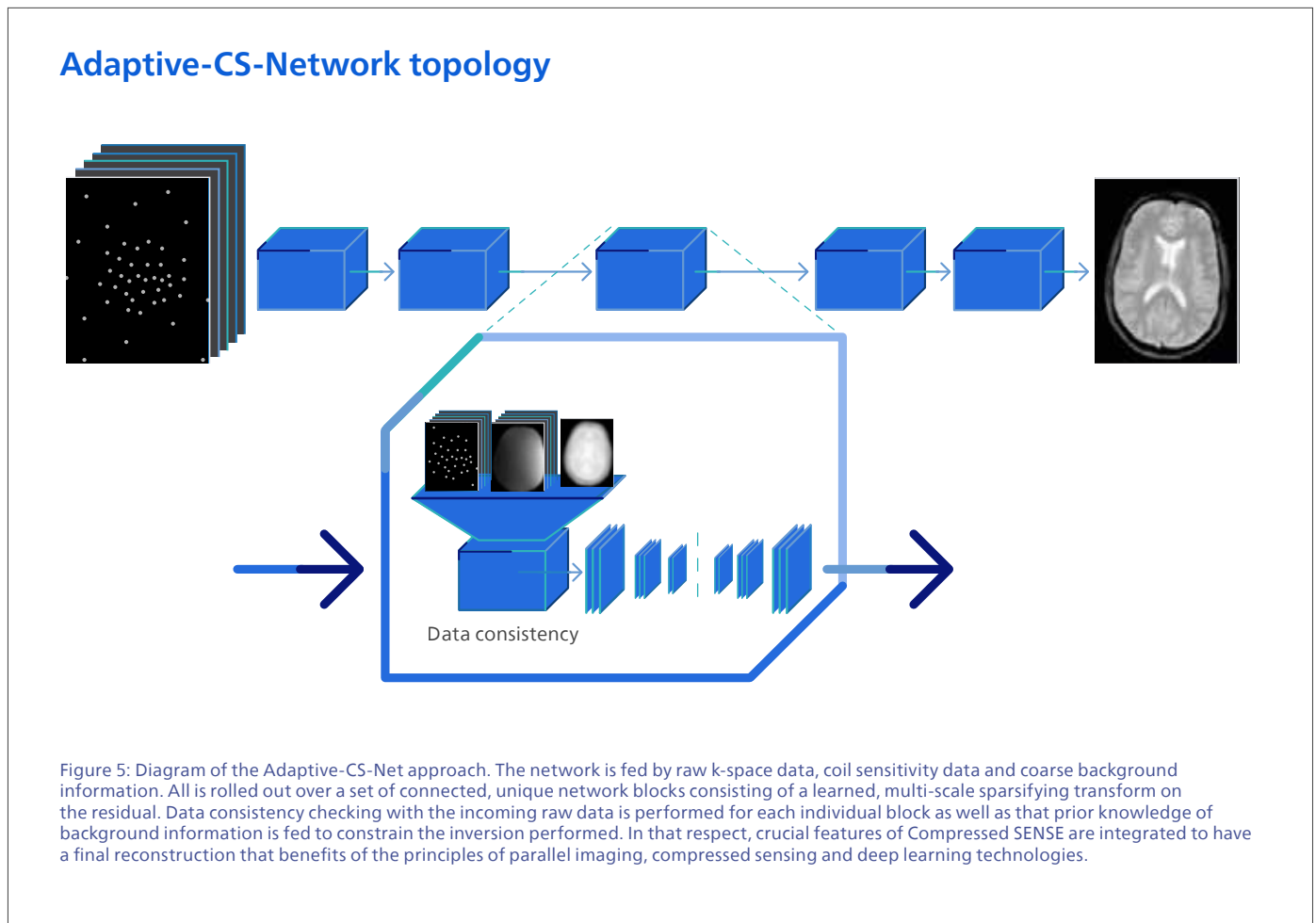

Why is the sampling pattern important?

Up to now, we mostly focused on the reconstruction and processing in the imaging chain as this is where AI solutions focus. However, it all starts with the acquisition as the sampling pattern plays a crucial role as well. The right sampling pattern will bring the optimal reconstruction image quality as it balances high and low frequency information to preserve details¹⁸. As the Adaptive-CS-Net is trained for multi-scale sparsity, it benefits the most from a sparsity promoting sampling pattern. The balanced, continuous

non-uniform sampling pattern of Compressed SENSE has already been proven to be able to fulfil this criterium. Conventional regular sampling schemes can also be used, but acceleration capabilities will be more limited as subsampling artifacts will already occur at lower acceleration factors. The denoising capabilities of deep learning implementations acting on regular sampled data can be similar, but aliasing artifacts will hamper image quality and, hence, acceleration capabilities, see Figure 6.

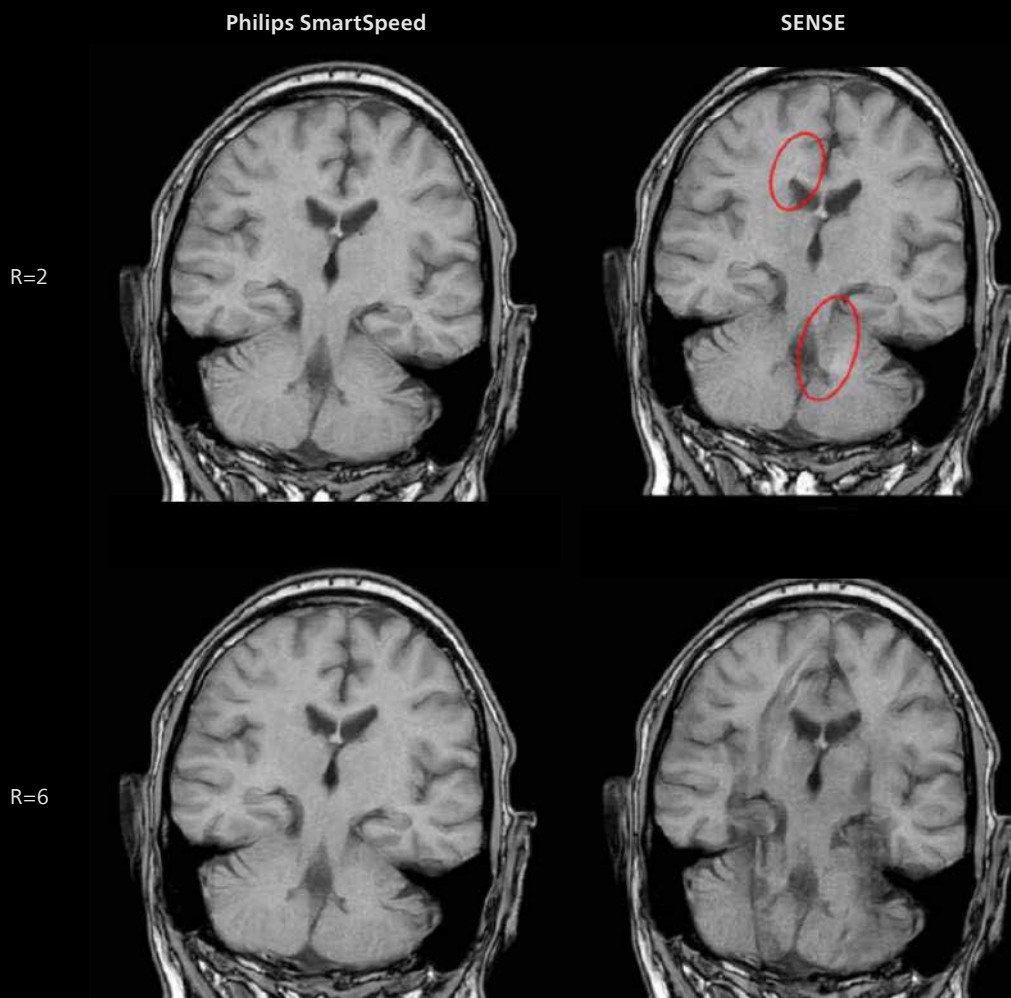

Figure 6: Comparison between non-uniform variable density sampling as with Philips SmartSpeed AI (left) and a conventional regular sampling scheme with the Adaptive-CS-Net based reconstruction (right) for an acceleration factor of 2 (top) and 6 (bottom). For both sampling schemes a unique realization of the network was realized in which the sampling scheme was taken into account to train the noise realization. The images show that a comparable denoising power is realized, but that under-sampling artifacts exist under acceleration factor ($R=2$) with the regular sampling scheme while with Philips SmartSpeed AI even with higher acceleration factor ($R=6$) it is possible to retrieve good IQ from the same undersampling rate because of the combination of the sampling pattern and the AI based recon.

What makes Philips SmartSpeed AI unique?

Adaptive-CS-Net deep learning technology applied at the beginning of the recon chain

Philips SmartSpeed AI is completely integrated in the acquisition and reconstruction acceleration engine and the Adaptive-CS-Net is trained to cover all anatomical domains and image contrasts over a wide range of acceleration factors and resolutions. This makes Philips SmartSpeed AI as versatile as Compressed SENSE which is unparalleled in the application range. It can be applied in any anatomical area for all contrasts for 2D and 3D sequences including complex image output. The latter has the benefit that any image processing steps can be applied. Therefore, Philips SmartSpeed AI is

for instance compatible with mDixon, SWIp and PCA. Image fidelity is maintained by the inherent data consistency of the Adaptive-CS-Net roll-out.

Unique sampling pattern

The unique non-uniform variable density subsampling is designed to promote incoherence that is trained into the Adaptive-CS-Net. Unlike other existing AI techniques, the acceleration is realized by genuine subsampling and not by a reduction of the k-space extend or number of signal averages. Accelerated sampling of the whole k-space extend provides true resolution in shorter scan times.

Compute platform and interface for deployment of AI innovation

Philips SmartSpeed is delivered with a graphics processing unit (GPU) for on-the-fly reconstruction times with the Philips SmartSpeed reconstruction framework. GPU's are well equipped for the processing of DL algorithms, both the training of the model as well as the deployment. The modular setup of the reconstruction pipeline with the Recon2.0 platform allows for easy integration of any algorithm or processing steps directly on the scanner. This also holds for home-built DL reconstruction steps to deploy directly on the scanner. On top of that, the PRIDE image processing interface allows to initiate any home-built post-processing DL algorithms based on input from single or multiple scans. The initiation is automatically started after the relevant scans are finished and performed at computing hardware to be connected to the scanner computer.

What are the clinical benefits of Philips SmartSpeed AI?

Philips SmartSpeed AI brings faster imaging, reduced motion sensitivity and higher resolution by sampling across the full k-space to capture the high frequency information. The support for multiple contrasts of 2D and 3D scans as well as derived information like fat-free imaging with mDixon ensures that shorter scan times are not realized only for single scans, but that the whole examination time is reduced. This is obviously beneficial for patient comfort and compliance. Through the novel design of the Adaptive-CS-Net, Philips SmartSpeed AI is up to 3 times faster than conventional

parallel imaging and can increase resolution up to 65%* to deliver outstanding image quality for diagnostic confidence. The variable density non-uniform sampling scheme allows scans to be accelerated with k-space coverage to the full extent such that higher frequencies (and hence, anatomical details) are captured. This results in truly high-resolution images in which fine structures can be discriminated. Examples of Philips SmartSpeed AI are a on the next pages.*

"I think Philips SmartSpeed is useful especially for high-resolution imaging. The excellent denoising capability in Philips SmartSpeed allows imaging with extremely high resolution without increasing the scan time. This is particularly important, for example, in depicting small lesions in the vascular system."

Takashige Yoshida, RT, Ph.D. Tokyo Metropolitan Police Hospital

"I think Philips SmartSpeed is useful especially for high-resolution imaging. The excellent denoising capability in Philips SmartSpeed allows imaging with extremely high resolution without increasing the scan time. This is particularly important, for example, in depicting small lesions in the vascular system."

Dr. Bratke, Radiologist - Expert in Musculoskeletal Imaging, University Hospital of Cologne

Brain – ~50% reduced exam time covering both 2D and 3D scans*

Conventional Acceleration. Exam time: **16:32 min**

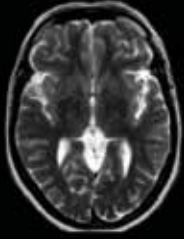

Axial 2D T2w TSE
0.6x0.75x5.0 mm
2:31 min

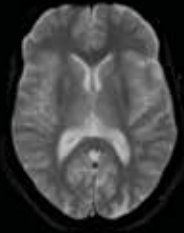

Axial 2D T2w FFE
0.9x1.1x5.0 mm
3:32 min



3D T1w TFE
1.1x1.1x1.1 mm
5:11 min

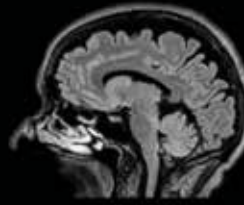

3D BrainView FLAIR
1.2x1.2x1.2 mm
4:43 min

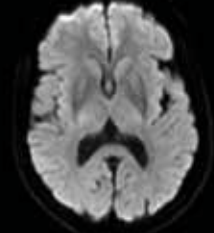

DWI b1000
1.5x2.0x5.0 mm
35 sec

Philips SmartSpeed AI. Exam time: **8:32 min**

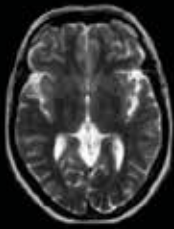

Axial 2D T2w TSE
0.6x0.75x5.0 mm
1:25 min

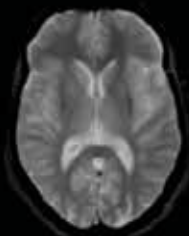

Axial 2D T2w FFE
0.9x1.1x5.0 mm
2:00 min



3D T1w TFE
1.1x1.1x1.1 mm
2:08 min



3D BrainView FLAIR
1.2x1.2x1.2 mm
2:24 min

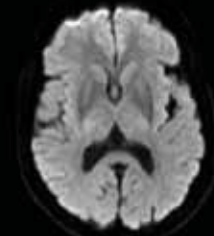

DWI b1000
1.5x2.0x5.0 mm
35 sec

Ingenia Ambition 1.5T

* Compared to conventional parallel imaging (SENSE)

Brain – Improved Image Quality

Conventional Acceleration

Philips SmartSpeed AI

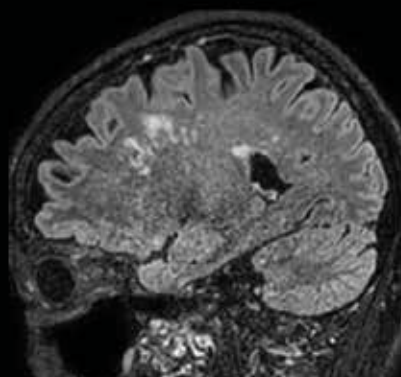

3D FLAIR
1.1x1.1x1.1 mm
Reduction factor 10
2:16 min

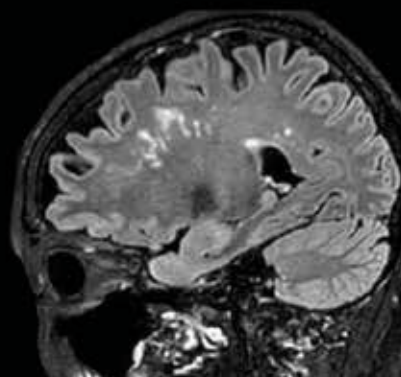

3D FLAIR
1.1x1.1x1.1 mm
Reduction factor 10
2:24 min

Cardiac – Improved Image Quality

Conventional Acceleration



Cine bTFE
1.6x1.9x8.0 mm
Reduction factor 4
4.2 sec

Philips SmartSpeed AI

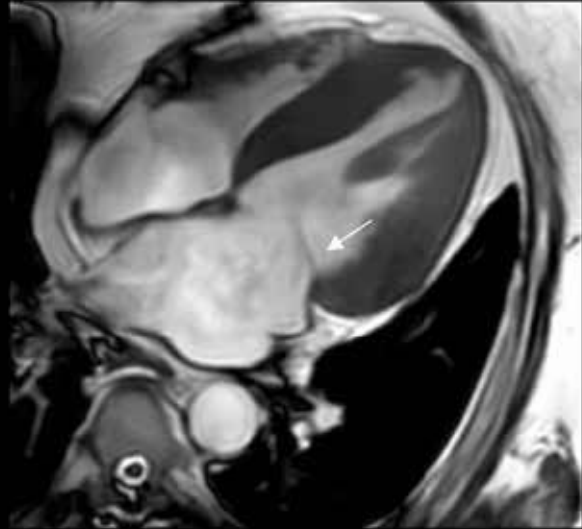

Cine bTFE
1.6x1.9x8.0 mm
Reduction factor 4
4.2 sec

Courtesy: Tokyo Metropolitan Police Hospital, Japan. Ingenia Elition X 3.0T

Prostate – Scan time reduction

Compressed SENSE

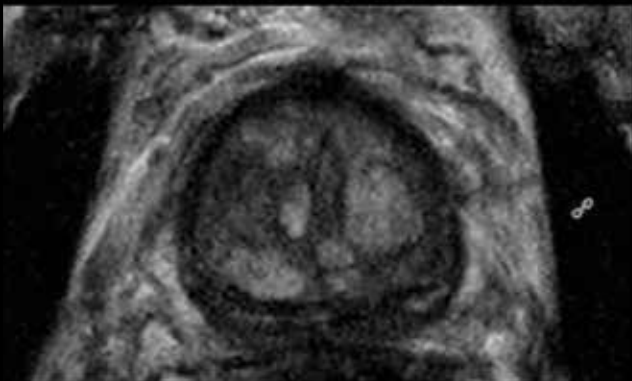

Axial T2w TSE
0.46x0.50x3.0 mm
Reduction factor 1.7

4:45 min

Philips SmartSpeed AI

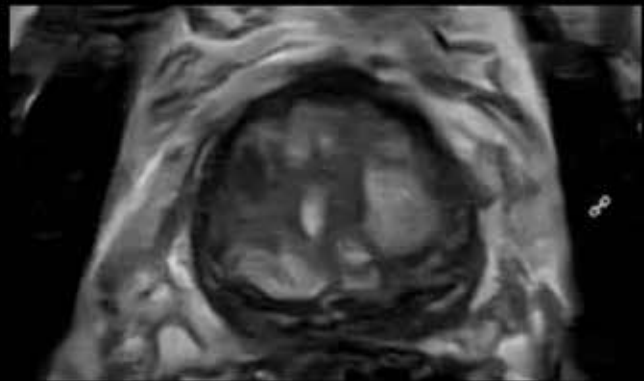

Axial T2w TSE
0.46x0.50x3.0 mm
Reduction factor 4.8

1:59 min

Courtesy: Technical University of Munich, Germany. Ingenia Elition X 3.0T Ingenia Ambition

Prostate with brachytherapy seeds – Scan time reduction

Conventional Acceleration

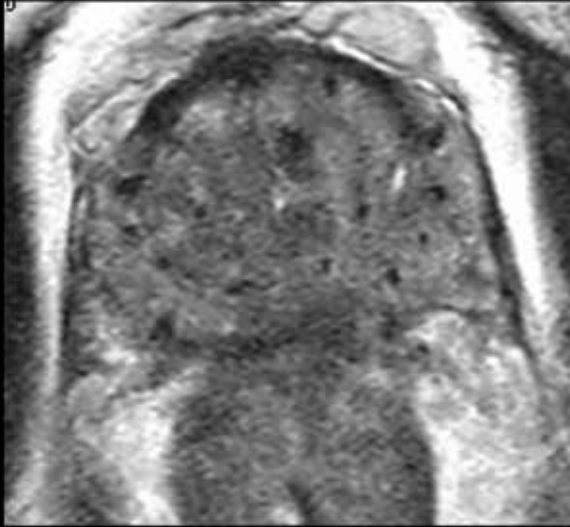

Axial T2w TSE
0.40x0.62x3.0 mm
Reduction factor 2.0
3:04 min

Philips SmartSpeed AI

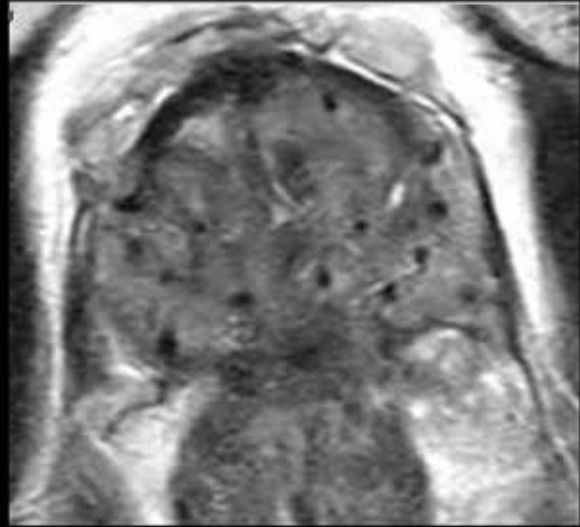

Axial T2w TSE
0.40x0.62x3.0 mm
Reduction factor 3.0
2:15 min

Courtesy: Tokyo Metropolitan Police Hospital, Japan. | Courtesy: Tokyo Metropolitan Police Hospital, Japan. Ingenia Elition X 3.0T ingenia Elition X 3.0T

Spine – Scan time reduction, up to 3 times faster

Conventional
Acceleration



Sagittal 2D T1w TSE
0.8x1.0x4.0 mm
3:13 min

Philips
SmartSpeed AI



Sagittal 2D T1w TSE
1.0x1.0x4.0 mm
1:16 min

Conventional
Acceleration



Sagittal 2D T2w TSE
0.8x1.0x4.0 mm
3:03 min

Philips
SmartSpeed AI



Sagittal 2D T2w TSE
1.0x1.0x4.0 mm
0:59 min

Knee – Scan time reduction

Compressed SENSE



Sagittal 2D PDw TSE Fatsat
0.35x0.43x3.0 mm
Reduction factor 2.0

2:45 min

Philips SmartSpeed AI



Sagittal 2D PDw TSE Fatsat
0.35x0.43x3.0 mm
Reduction factor 3.0

1:54 min

Courtesy : University Hospital Cologne, Germany. Ingenia 3.0T

Knee – Higher resolution in similar scan time

Conventional Acceleration

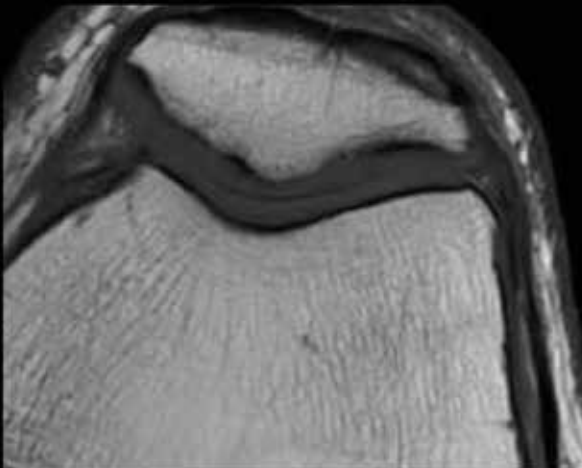

Axial 2D T1w TSE
0.42x0.48x3.0 mm
Reduction factor 1.2
2:17 min

Philips SmartSpeed AI

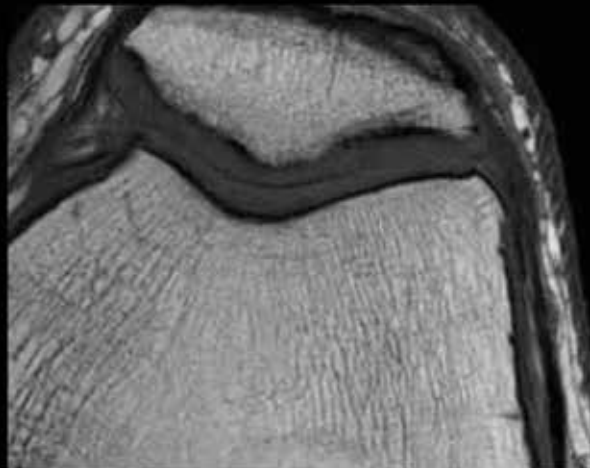

Axial 2D T1w TSE
0.34x0.34x2.0 mm
Reduction factor 2.0
2:08 min

Ingenia Elition X 3.0T

Breast cancer – Scan time reduction

Conventional Acceleration

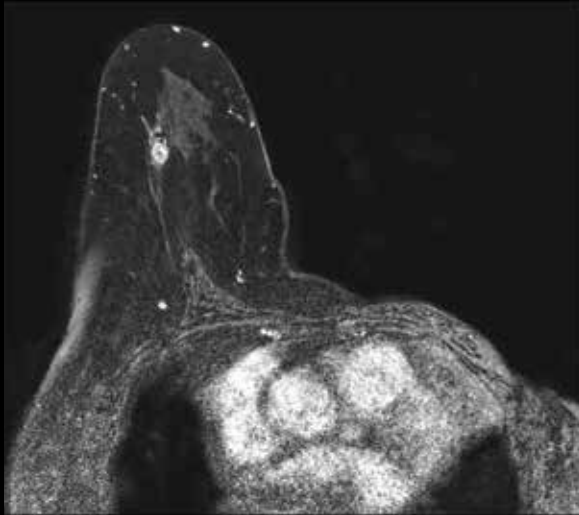

3D T1w mDixon post contrast
0.7x0.7x0.7 mm
Reduction factor 4.0
4:34 min

Philips SmartSpeed AI

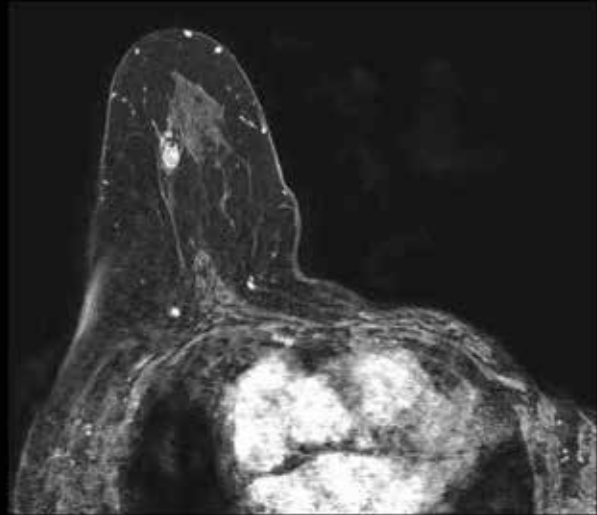

3D T1w mDixon post contrast
0.40x0.62x3.0 mm
Reduction factor 8.0
2:02 min

Courtesy: Tokyo Metropolitan Police Hospital, Japan. Ingenia Elition X 3.0T

Hepatobiliary phase liver – Higher, 3D isotropic resolution in same breath hold time

Compressed SENSE

1.45x1.45x2.0 mm
Reduction factor 8
13 sec

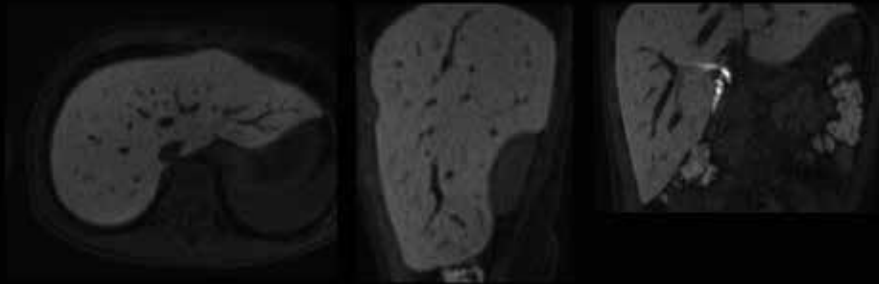

Philips SmartSpeed AI

1.2x1.2x1.2 mm
Reduction factor 12
13 sec

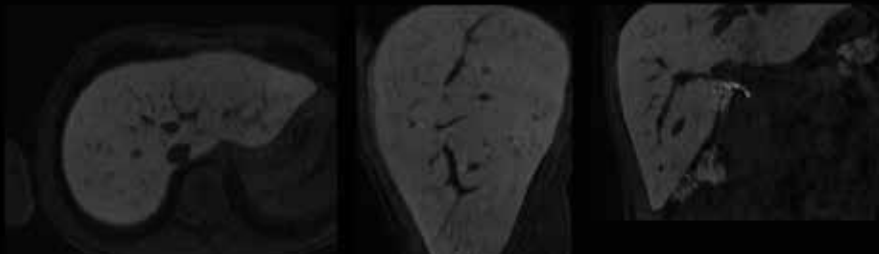

Courtesy : Korea University Guro Hospital, Seoul, Korea. Ingenia Elition X 3.0T

Hippocampus – Higher resolution in similar scan time

Conventional Acceleration

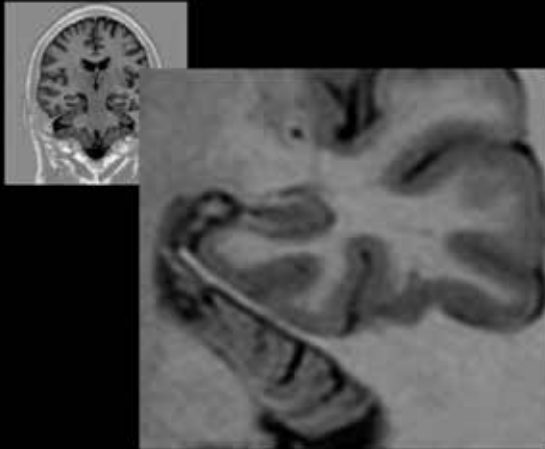

2D T1W IR
0.8x1.0x3.0 mm
Reduction factor 1.1
4:57 min

Philips SmartSpeed AI

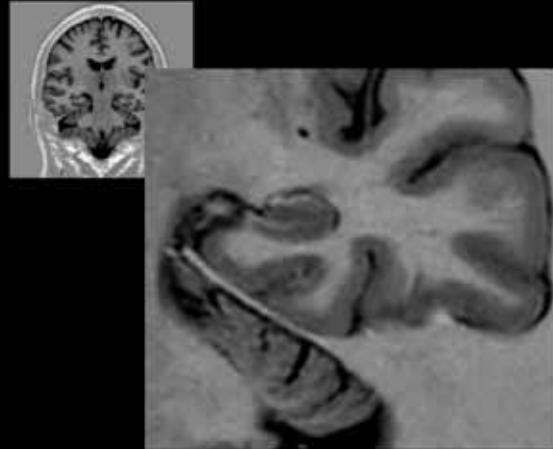

2D T1W IR
0.6x0.7x3.0 mm
Reduction factor 2.1
4:05 min

Ambition 1.5T, dS Head Coil

Brain suspicion of aneurysm – Higher resolution in similar scan time

Compressed SENSE



3D TOF
0.5x0.8x1.1 mm
Reduction factor 4.0
3:51 min

Philips SmartSpeed AI



3D TOF
0.4x0.4x0.8 mm
Reduction factor 5.4
3:49 min

Courtesy: Tokyo Metropolitan Police Hospital, Japan. Ingenia Elition X 3.0T

Ankle – Scan time reduction

Conventional Acceleration

Philips SmartSpeed AI

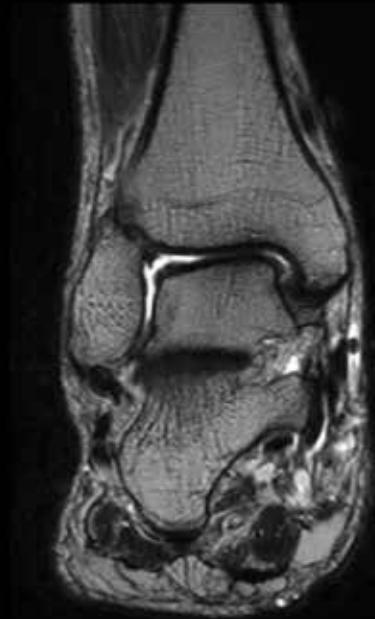
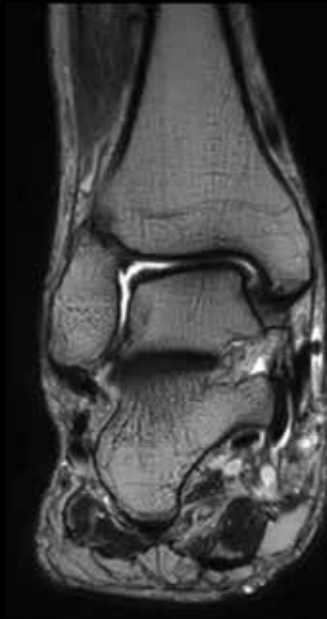
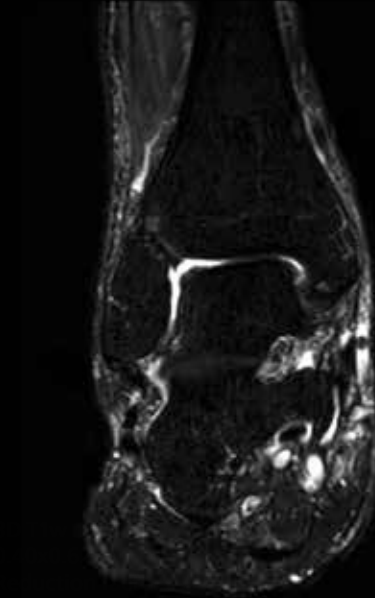
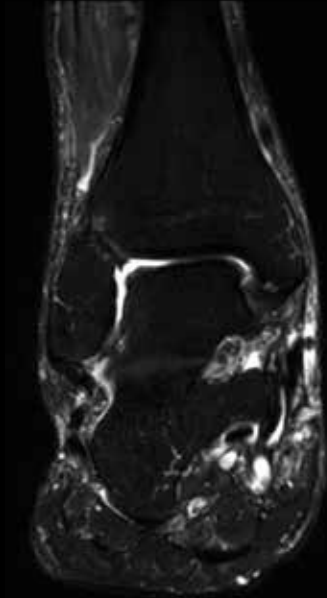

Coronal 2D T2w mDixon TSE w / IP
0.5x0.8x2.5 mm
Reduction factor 1.5 / 2 NSA

4:59 min

Coronal 2D T2w mDixon TSE w / IP
0.5x0.8x2.5 mm
Reduction factor 2.1 / 1 NSA

1:44 min

Philips SmartSpeed MotionFree: a unique solution for fast and motion robust imaging

Philips SmartSpeed MotionFree removes the compromise between motion robust scanning on the one hand, and speed and contrast on the other hand. As already outlined in the introductory section, motion is among the major sources of annoyances in daily MRI practice, causing loss of diagnostic confidence and rescans and hence, longer scan procedures. This clearly indicates the need for fast and motion robust scanning. With Philips SmartSpeed MotionFree, the acceleration of the Compressed SENSE reconstruction and the motion robust acquisition strategy of MultiVane XD are combined to guarantee diagnostic image quality in challenging conditions with a lot of physiological motion or

restless patients, within scan times that are comparable to the non-motion-compensated equivalent. Philips SmartSpeed MotionFree reduces gross motion, breathing motion and pulsatility artifacts in over 90% of the cases compared to Cartesian imaging. This section explains how Philips SmartSpeed MotionFree acquisition and reconstruction are built up in order to realize the same contrasts and appearance as conventional Cartesian acquisitions. The setup for easy on-the-fly conversion from Cartesian to Philips SmartSpeed MotionFree is explained, and clinical examples over multiple application areas are provided.

What makes Philips SmartSpeed MotionFree robust to motion?

Philips SmartSpeed MotionFree utilizes the MultiVane XD k-space trajectory as its base for motion robustness. This technique consists of many Cartesian k-space lines which are grouped together, resulting in a "blade", and rotated around the center of k-space (shown in the purple box in Figure 7). There is a central circular area of k-space, with a diameter equal to the width of each blade. This overlapping area is sampled by each of the blades.

The intrinsic averaging effect obtained by these overlapping profiles in the k space helps in the reduction of physiological motion artifacts such as breathing or swallowing. Additionally, data from this area can be used to reconstruct a low-resolution image for each blade. By comparing these images pair-wise using a correlation technique, the relative motion between the pair of blades can be quantified and removed from the final reconstruction¹⁹. All of these features contribute to make Philips SmartSpeed MotionFree robust to motion.

How does the sampling scheme fit with the Compressed SENSE reconstruction?

The sampling scheme of Philips SmartSpeed MotionFree is inherently suited for the Compressed SENSE reconstruction in the Philips SmartSpeed Engine. The sampling density decreases towards the outer parts of k-space providing a natural form of variable density,

while the non-Cartesian sampling also promotes incoherence. Scan time reduction is achieved naturally by reducing the overall number of profiles acquired while still creating a smooth incoherent sampling pattern.

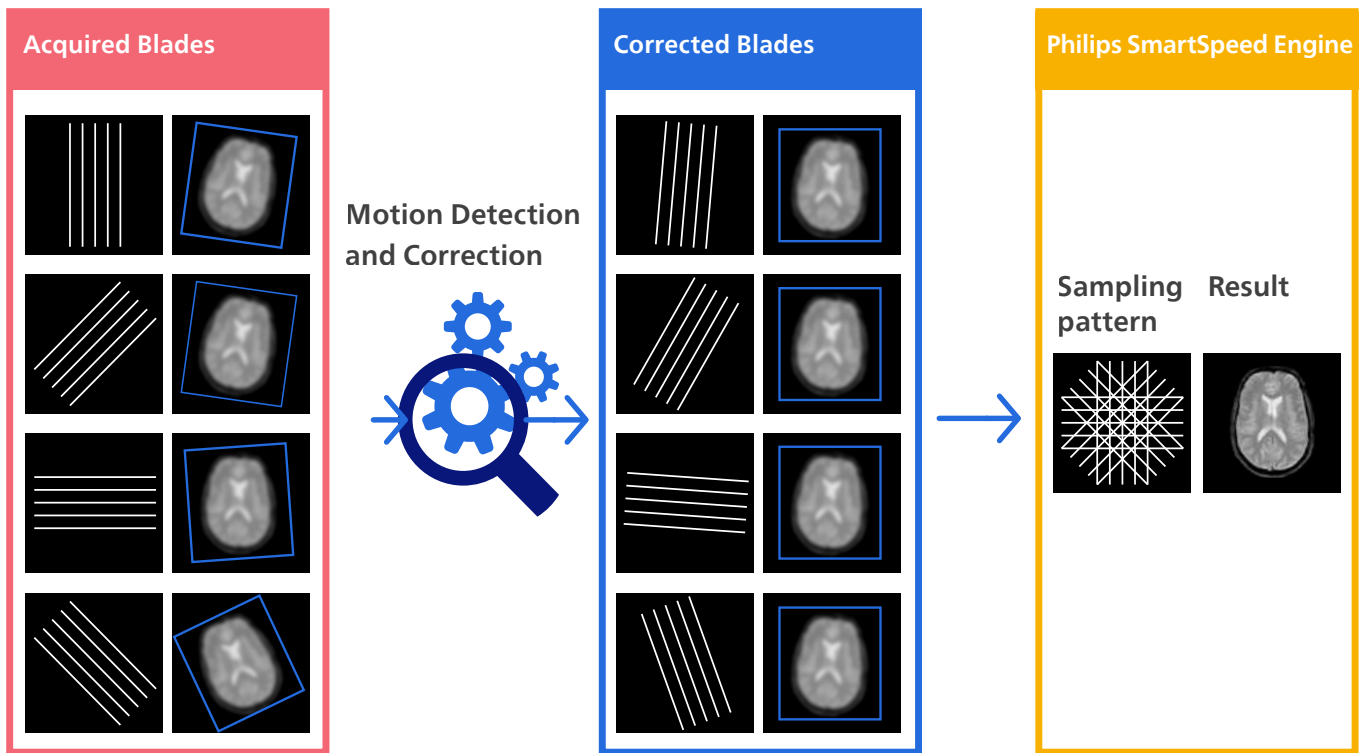

Figure 7: Schematic representation of the motion robustness of Philips SmartSpeed MotionFree. A blade-wise acquisition scheme is performed, after which motion is detected and corrected between the individual blades. The motion-corrected data is fed into the Philips SmartSpeed Engine.

Where can I use Philips SmartSpeed MotionFree?

Philips SmartSpeed MotionFree is a 2D multi-slice technique that can be applied in all anatomies for all patients. It is especially advantageous for patients who are unable to keep still during the exam or experience involuntary movements. Also, for anatomical areas where motion is very likely to occur, for example breathing motion in shoulder and abdomen, swallowing in head and neck, or peristaltic motion in the pelvis benefit from this technique. All clinically relevant contrasts can be realized, allowing for a complete examination with Philips SmartSpeed MotionFree. Regular T1, T2, and proton density weighted imaging can be

performed with the support of prepulses like fat saturation (SPAIR/ SPIR) or STIR. Philips SmartSpeed MotionFree allows the output of real images for applications for example, the detection of cortical lesions in the brain and multiple sclerosis lesions in the spine, or the analysis of white matter myelination in the pediatric brain. It is also compatible with mDixon, for which an efficient 2pt approach is used to realize water, fat, inphase and out-phase images²⁰. Lastly, the majority of scans performed are TSE type of sequences, but in Philips SmartSpeed MotionFree it is also possible to use fast field echo (FFE).

How are multiple contrasts realized?

As with regular Cartesian scanning, protocols can be fully optimized to realize optimal echo and repetition times, echo spacing, etc. However, unlike Cartesian scanning, almost all profiles in a single TSE shot pass close to the center of k-space, potentially impacting the image contrast. To compensate for this effect, in Philips SmartSpeed MotionFree, profiles are assigned

a weight in reconstruction relative to the desired echo time. Measurement data at the desired echo time have the strongest weight and determine the final contrast. In this way, the iterative reconstruction in the Philips SmartSpeed Engine is fully leveraged as the weighting of the profiles is integrated in the data consistency step for each single coil element.

Can I easily convert existing Cartesian protocols to Philips SmartSpeed MotionFree?

Conversion from a Cartesian to a non-Cartesian protocol has never been so easy as with Philips SmartSpeed MotionFree. Switching is done via the Acquisition mode parameter from Cartesian to MotionFree. All sequence settings like the sampling scheme and reconstruction weights for optimal contrast are automatically optimized to realize the same look and feel as Cartesian scans. For example, the non-Cartesian Nyquist criterium is taken into

account based on the planned oversampled field of view (FOV), such that the width of the overlapping blade area is automatically optimized. Furthermore, Philips SmartSpeed MotionFree supports rectangular FOV planning, user-defined asymmetric oversampling in the phase and readout encoding directions, and the selection of the preferred water-fat-shift direction. This makes the planning for the operator similar to the setup of a Cartesian scan.

What are the clinical benefits of Philips SmartSpeed MotionFree?

Motion robust multi-slice scans have been available for some time. The drawbacks have been the lack of availability of contrasts and the time it takes to acquire these. Philips SmartSpeed MotionFree fills both these gaps. On top of that, motion artifacts are minimized while the image appearance with respect to the Cartesian equivalence has been maintained. The fast acquisition and contrast capabilities make it possible to build a complete examination on Philips SmartSpeed MotionFree.

This will remove the need for rescans that can happen when patients are restless or in the presence of involuntary (uncontrolled) physiological motion. As a result, examination times are very predictable, reducing potential delays in the daily management. Patient experience improves when scans do not have to be repeated, and breath holds can be avoided.

“Philips SmartSpeed MotionFree is the best technique for routine clinical examinations, because it is robust, really motion-free and has excellent image quality with fast scan times. We will not be worried about re-scan/extra scans due to patient motion.”

Prof. M. Niitsu, MD PhD, Saitama Medical University, Japan

Shoulder rotator cuff injury – Motion robustness for all contrasts

Conventional Cartesian Acquisition

Philips SmartSpeed MotionFree

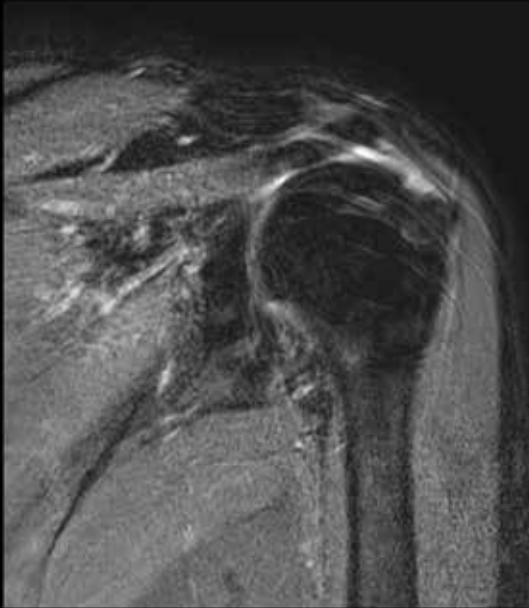

Coronal 2D T2w TSE Fatsat
0.48x0.62x3.0 mm
2:26 min

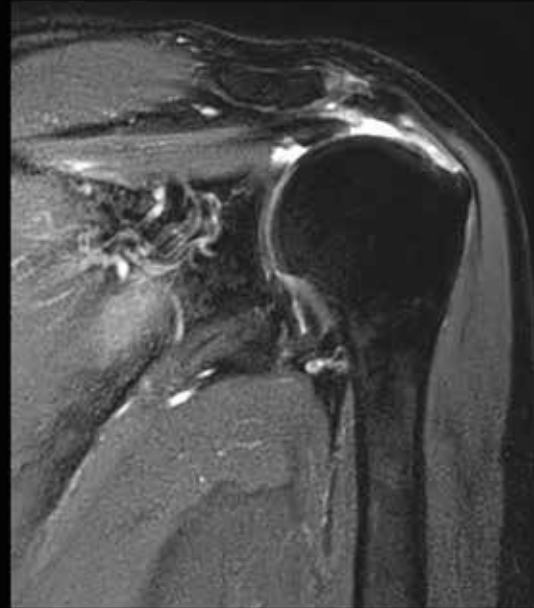

Coronal 2D T2w TSE Fatsat
0.55x0.55x3.0 mm
2:20 min



Coronal 2D PDw TSE
0.38x0.51x3.0 mm
2:42 min



Coronal 2D PDw TSE
0.45x0.45x3.0 mm
2:34 min

Prostate – Shorter scan times

MultiVane XD

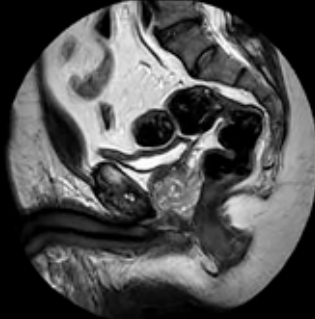

Sagittal 2D T2w TSE
0.69x0.69x3.0 mm
Reduction factor 1.5
3:37 min



Axial 2D T2w TSE
0.69x0.69x3.0 mm
Reduction factor 1.5
3:51 min

Philips SmartSpeed MotionFree

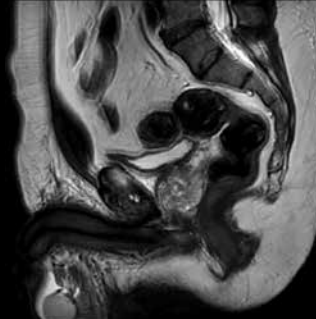

Sagittal 2D T2w TSE
0.69x0.69x3.0 mm
Reduction factor 2.0
2:42 min

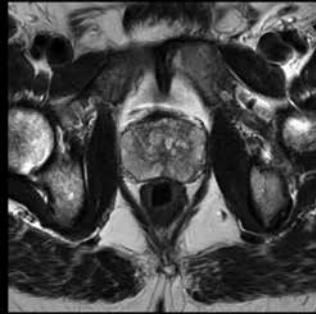

Axial 2D T2w TSE
0.69x0.69x3.0 mm
Reduction factor 2.5
2:51 min

Courtesy: University Hospital Bonn, Bonn, Germany. Ingenia 3.0T

Rectum fistula – Improved sharpness by inherent motion robustness

Conventional Cartesian Acquisition

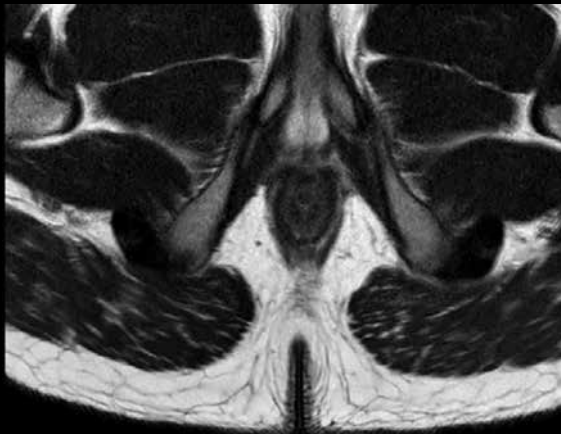

Axial 2D T2w TSE
0.6x0.6x4.0 mm
Reduction factor 2.2
3:12 min

Philips SmartSpeed MotionFree

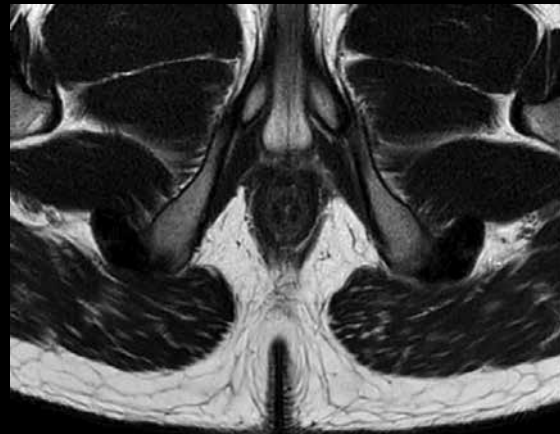

Axial 2D T2w TSE
0.6x0.6x4.0 mm
Reduction factor 2.0
3:13

Courtesy: Kantonsspital Winterthur, Switzerland. Ingenia 1.5T

Head & Neck tumor – Motion robust imaging in similar scan time

Conventional Cartesian Acquisition

Philips SmartSpeed MotionFree

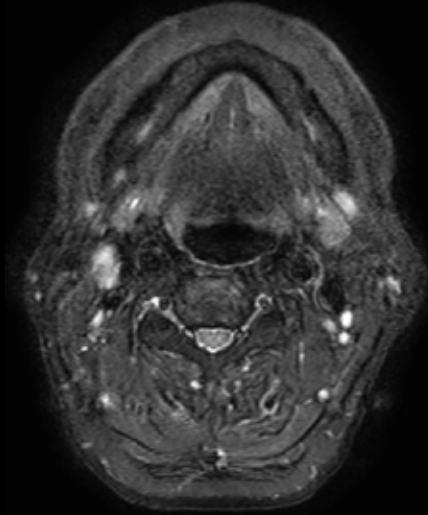

Axial 2D STIR
0.72x1.04x4.0 mm
Reduction factor 1.2
2:51 min

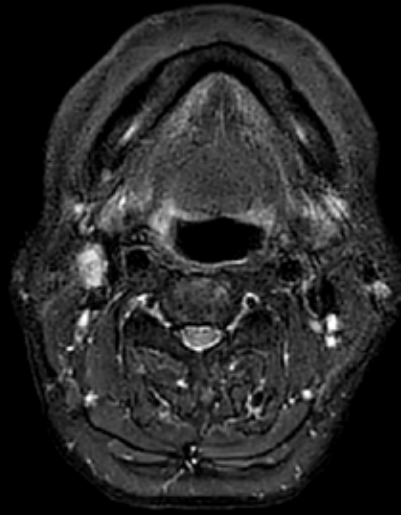

Axial 2D STIR
0.86x0.86x4.0 mm
Reduction factor 1.6
2:55 min

Courtesy: Kumamoto University Hospital, J Courtesy: University Hospital Bonn, Bonn, Germany. Ingenia 3.0T apan. Ingenia CX 3.0T

Spine - Motion robustness in the similar scan time

Conventional Cartesian Acquisition

Philips SmartSpeed MotionFree



Coronal 2D STIR
1.0x1.0x4.0 mm
3:34 min

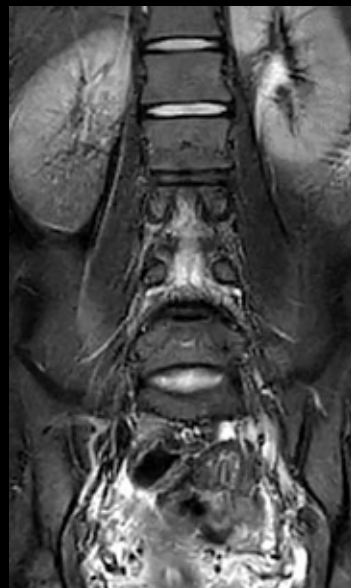

Coronal 2D STIR
1.0x1.0x4.0 mm
3:37 min

Ingenia Elition X 3.0T
Conventional acceleration = Philips SENSE

Philips SmartSpeed 3DFreeBreathing: fast breath hold-free imaging

Philips SmartSpeed 3DFreeBreathing allows the acquisition of 3D T1-weighted gradient echo scans without the need for breath holding. It is intrinsically robust for motion artifacts that can originate from breathing, peristaltic motion, swallowing

and cardiac pulsatility. Philips SmartSpeed 3DFreeBreathing combines the radial sampling strategy of 3DVane XD together with compressed SENSE in the Philips SmartSpeed Engine

What makes Philips SmartSpeed 3DFreeBreathing robust to motion?

Philips SmartSpeed 3DFreeBreathing is based on a radial stack-of-stars (SOS) sampling strategy. Radial SOS implies a radial sampling scheme in in-plane directions and Cartesian in the slice direction. Radial imaging is known to have more benign artifacts originating from motion compared to Cartesian sampling schemes, since with radial techniques the middle of k-space is passed for each spoke and motion is averaged out. Also, subsequent spokes are acquired

with a golden angle azimuthal angular distance such that motion is maximally distributed over the total acquisition, resulting in a further reduction of related artifacts. In addition, breathing navigators can be added to reject data in the inspiration phase to limit the extreme differences in motion states that exist or to adapt the slice position to account for the detected breathing motion.

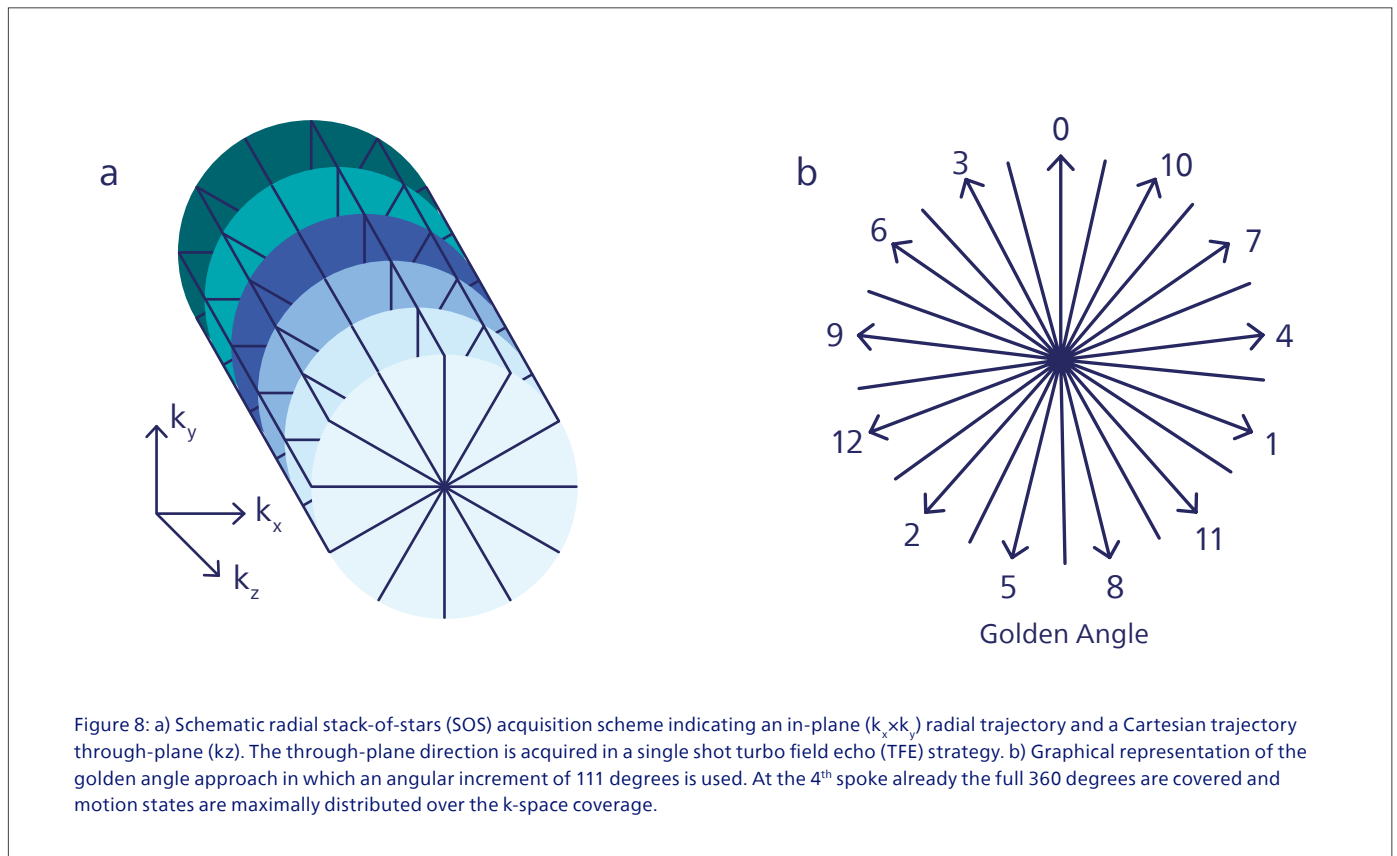

How is acceleration realized in Philips SmartSpeed 3DFreeBreathing?

The 3D radial SOS sampling scheme is integrated in the Philips SmartSpeed Engine. Acceleration in Philips SmartSpeed 3DFreeBreathing is realized by sub-sampling in both the in-plane and through-plane directions via a reduction of radial spokes and slice phase encoding steps (Figure 9). The under-sampling artifacts

that may exist are handled via the robust Compressed SENSE reconstruction scheme. Similar to Philips SmartSpeed MotionFree, radial sampling is inherently suited for such a scheme as subsampling artifacts are by nature incoherent and distributed.

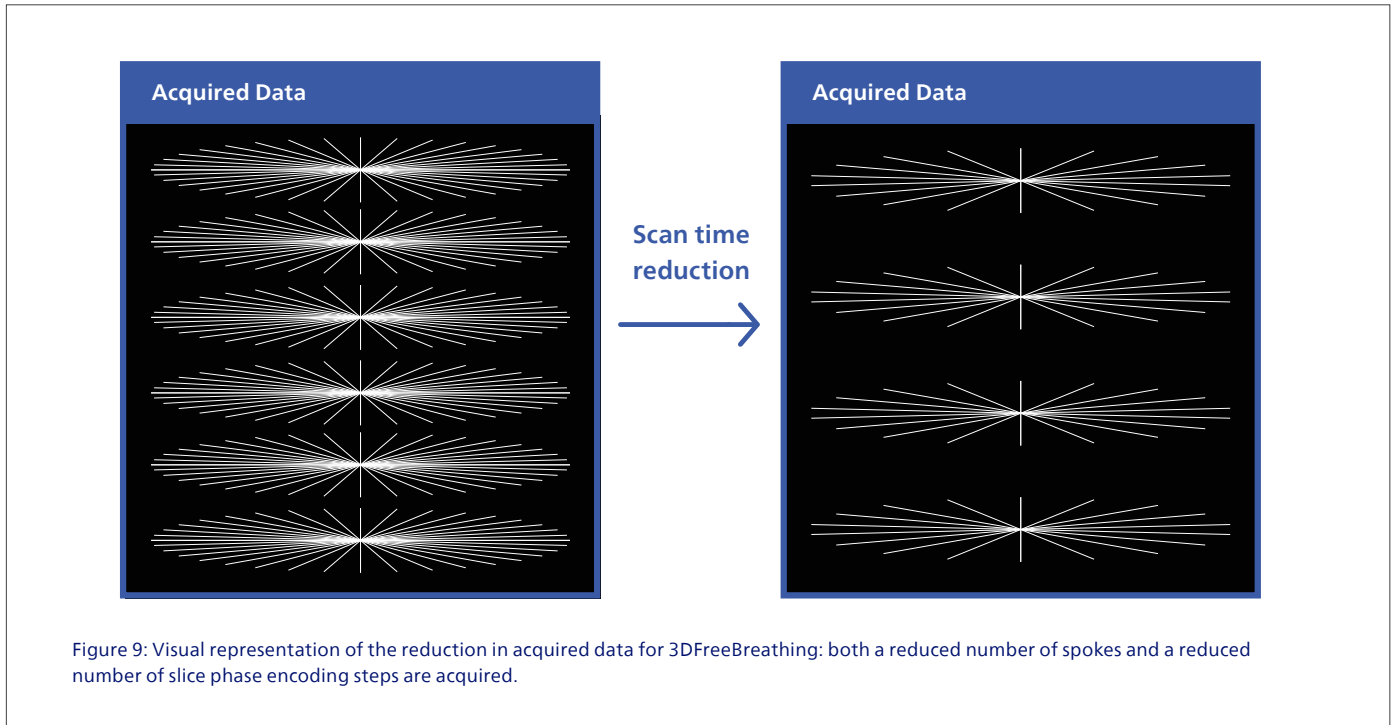

Can mDixon be used with Philips SmartSpeed 3DFreeBreathing?

3D T1w imaging is most often performed with fat suppression. Next to spectral fat suppression with inversion pulses like SPAIR or SPIR, mDixon can be also used. A dual echo readout with the flexible echo spacing of mDixon²⁰ is integrated in the radial SOS acquisition scheme. The water-only image realizes uniform fat suppression

over large, challenging field-of-views. The use of mDixon brings the additional advantage that fat images as well as in-phase and out-phase contrasts are available. This allows for direct assessment of fatty content in potential lesions.

What are the clinical benefits of Philips SmartSpeed 3DFreeBreathing?

Philips SmartSpeed 3DFreeBreathing shortens the scan times of pre- and post-contrast 3D T1-weighted imaging commonly applied for high resolution imaging in the upper abdomen. With Philips SmartSpeed 3DFreeBreathing, the scan times of 3D T1-weighted scans become similar to the Cartesian counterparts.

This facilitates applying it as well to application domains where motion is less severe, like the head and neck area or breast. Ghosting artifacts due to swallowing or cardiac pulsation are minimized, and areas like the axilla for lymph node assessment are no longer obscured.

Breast and axillae – Avoiding motion ghosting in similar scan time

Compressed SENSE

Philips SmartSpeed 3DFreeBreathing

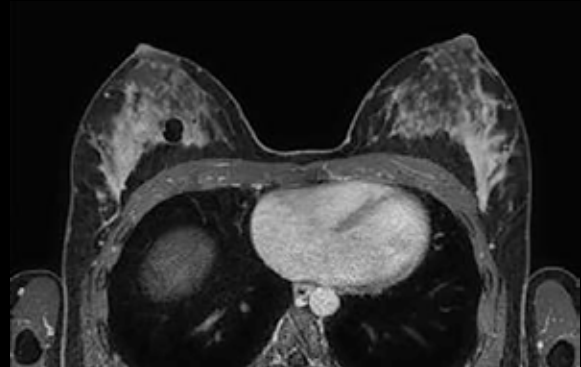
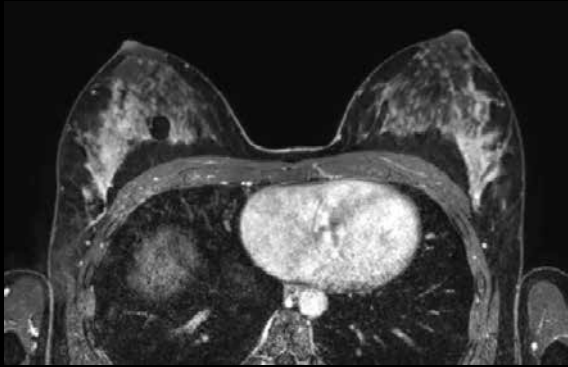

3D T1w mDixon post contrast
0.8x0.8x2.0 mm
Reduction factor 2.0
1:59 min

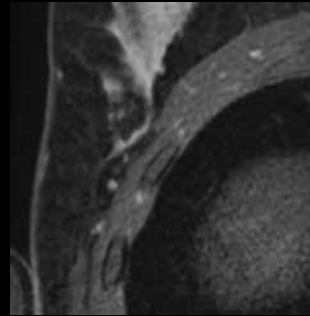
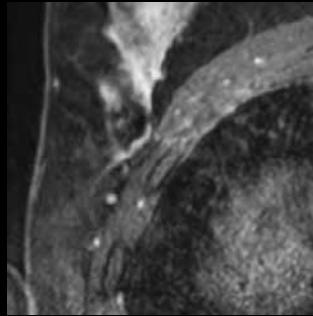

3D T1w mDixon post contrast
0.8x0.8x2.0 mm
Reduction factor 5.2
2:03 min

Courtesy: Winterthur Kantonsspital, Switzerland. Ingenia 1.5T

Liver – Shorter scan time

Conventional Acceleration

Philips SmartSpeed 3DFreeBreathing

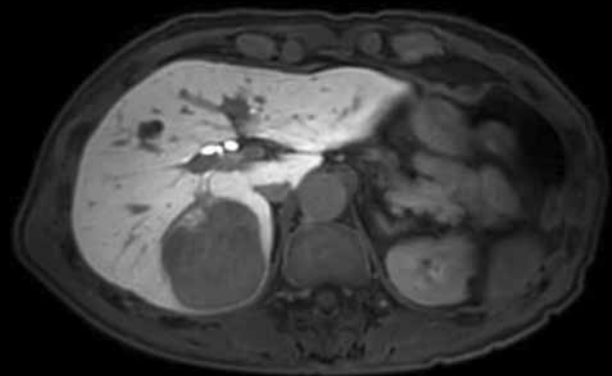
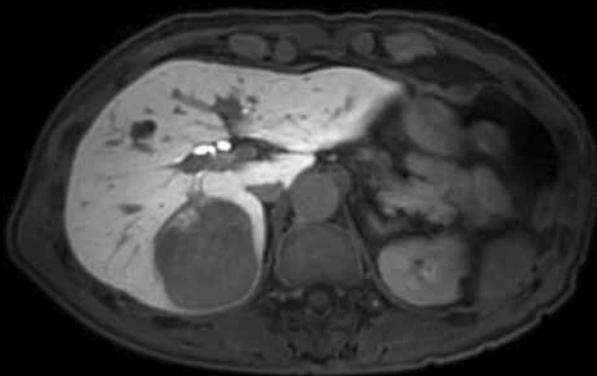

3D T1w TFE hepatobiliary phase
1.5x1.5x4 mm
Reduction factor 2.0
1:16 min

3D T1w TFE hepatobiliary phase
1.5x1.5x4 mm
Reduction factor 4.0
0:39 min

Courtesy: Shimada General Medical Center, Japan. Ingenia Elition X 3.0T

Liver – Higher resolution

Conventional Acceleration

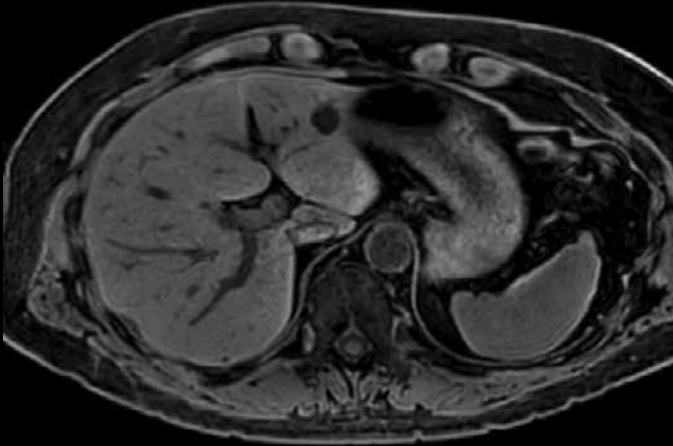

3D T1w TFE
1.5x1.5x3.0 mm
Reduction factor 1.6
1:38 min

Ingenia Elition X 3.0T

Philips SmartSpeed 3DFreeBreathing

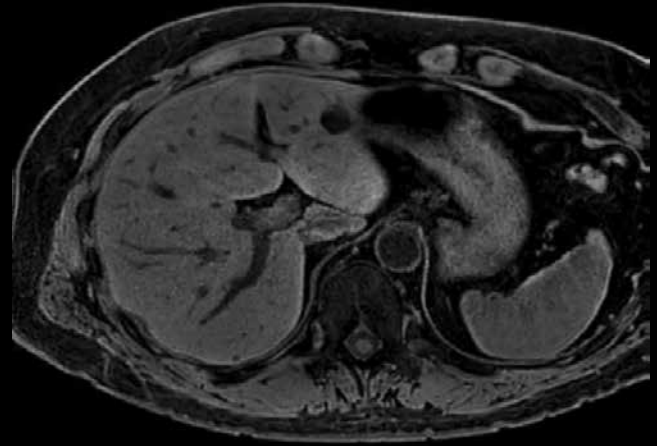

3D T1w TFE
1.1x1.1x3.0 mm
Reduction factor 3.2
1:38 min

Liver – Shorter scan time

Conventional Acceleration

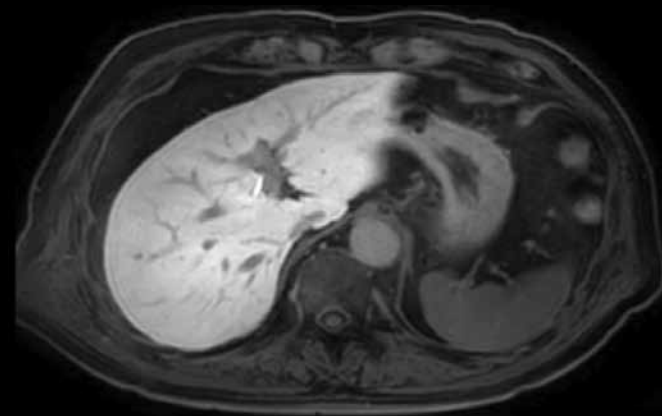

3D T1w mDixon hepatobiliary phase
1.5x1.5x4 mm
Reduction factor 2.0
1:22 min

Philips SmartSpeed 3DFreeBreathing



3D T1w mDixon hepatobiliary phase
1.5x1.5x4 mm
Reduction factor 4.0
0:42 min

Courtesy: Shimada General Medical Center, Japan. Ingenia Elition X 3.0T

Philips SmartSpeed Implant: Fast imaging of patients with implants

Performing musculoskeletal (MSK) imaging in patients with implants is challenging. With the introduction of technologies such as Orthopedic Metal Artifact Reduction (O-MAR XD)²¹, image quality has substantially improved. This enables abnormalities to be seen in areas close to metal implants that are obscured by susceptibility artifacts in regular Cartesian image acquisition techniques. The limitation of this technology is that it requires additional data

acquisition and therefore scan times are in the order of 7-10 minutes per required contrast. To obtain a comprehensive exam covering all required image contrasts (T1w, T2w, PDw, STIR), the total exam time is significantly longer than in exams without the need for metal artifact reduction. With Philips SmartSpeed Implant, the technology of O-MAR XD is integrated in the Philips SmartSpeed Engine to reduce the scan time of the aforementioned sequences significantly.

What makes Philips SmartSpeed Implant applicable for implant imaging?

Philips SmartSpeed Implant is based on O-MAR XD technology. In short, the magnetic field around metal implants is distorted. This results in image perturbations seen as areas with signal voids and areas with signal pile-up. In O-MAR XD, the View Angle Tilting (VAT) and Slice Encoding for Metal Artifact Correction (SEMAC) techniques are combined. VAT is an efficient technique for in-plane artifact correction, exploiting an extra gradient in the slice select direction

during the signal read-out. SEMAC augments the VAT method with phase encoding in the slice direction to realize both in-plane and through-plane artifact reduction. 2D slices are excited just as in a standard multi-slice sequence, resulting in distorted profiles. These slices are processed and combined into a single 2D image corrected for through-plane distortion.

How does Philips SmartSpeed help to accelerate imaging in patients with implants?

The SEMAC factor, the number of slices excited per 2D image, controls the amount of metal artifact reduction that can be achieved. A higher SEMAC factor inherently comes at the cost of scan time. It facilitates near-metal imaging, but it also results in a sparser

appearance of the image as shown in Figure 10. This inherent sparsity of the data makes it extremely suited for Compressed SENSE based reconstructions, allowing significant reductions in scan time compared to conventional parallel imaging.

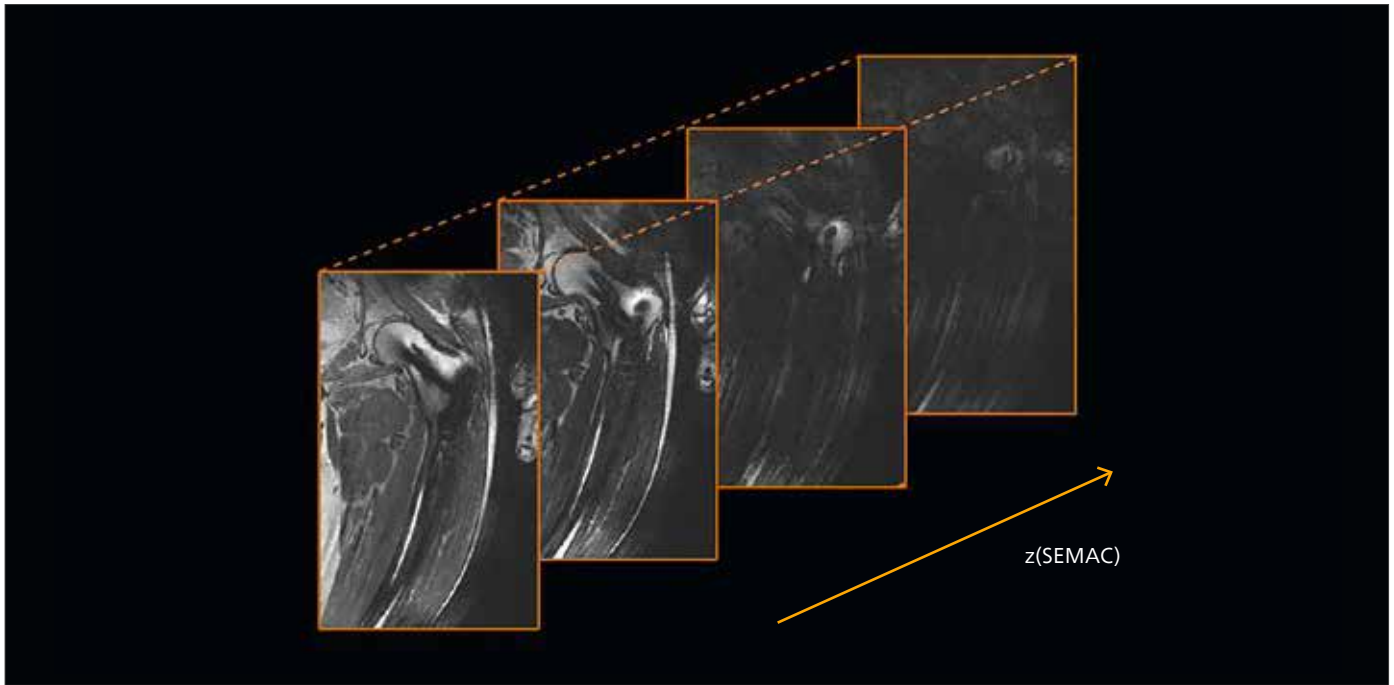

Figure 10: Acquisition of a single slice coronal hip with multiple SEMAC encoding steps (z), resulting in a sparse 3D volume.

Is Philips SmartSpeed Implant applicable for all contrasts and all anatomies?

Philips SmartSpeed Implant is designed for musculoskeletal imaging in the presence of metal implants, without any compromise on scan time compared to imaging without correction for metal imaging. It can be applied to different anatomical areas, such as knee, hip, shoulder and wrist. Furthermore, Philips SmartSpeed Implant

is applicable to a large variety of image contrasts including fat suppression: T1w, T2w, PDw and STIR. As a user, you can make your own trade-off between decreased exam time and improved image quality by tuning the SEMAC factor (z) to different levels of metal artifact reduction.

Can I use Philips SmartSpeed Implant for all implants?

Philips has simplified the scanning of patients with MR Conditional implants by introducing ScanWise Implant²², the industry's first MR user interface with guidance that allows the user to enter the implant manufacturer's condition only once and not scan-by-scan. All scan parameters are automatically adjusted to meet the implant safety

condition values entered by the operator and ScanWise Implant makes the MR system adhere to the conditions throughout the whole examination. ScanWise and Philips SmartSpeed Implant are compatible to allow the user to take full benefit of the speed-up in a safe environment.

What are the clinical benefits of Philips SmartSpeed Implant?

Compared to acquisitions and exams with O-MAR XD, the scan times decrease on average by 30% at 3T and 50% at 1.5T.

This brings metal implant imaging down to similar scan times as regular MSK protocols, therefore no compromise on scan time or artifact reduction needs to be made.

Hip implant – Short examination times

Conventional acceleration
Total exam time: 26:02 min

Philips SmartSpeed Implant
Total exam time: 14:20 min

Coronal 2D T2w TSE
1.3x1.45x3.5 mm
Reduction factor 2.4
6:18 min

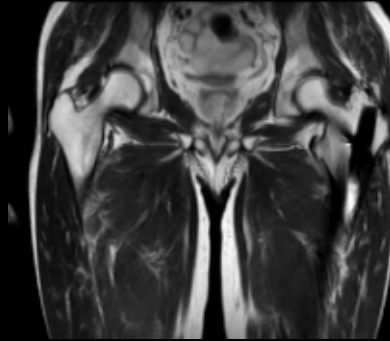

Coronal 2D T2w TSE
1.3x1.45x3.5 mm
Reduction factor 4.5
3:42

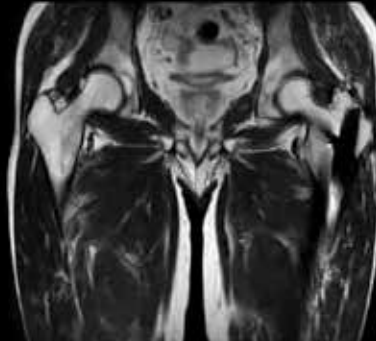

Coronal 2D STIR
1.5x1.8x3.5 mm
Reduction factor 2.5
6:39 min

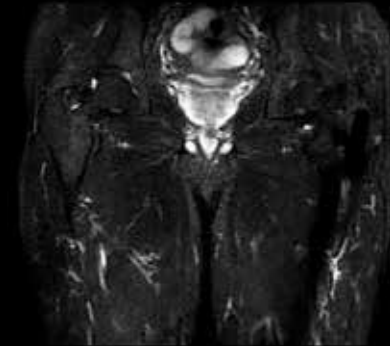

Coronal 2D STIR
1.5x1.8x3.5 mm
Reduction factor 2.5
3:25 min

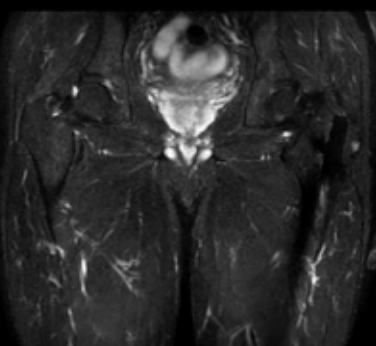

Coronal 2D PDw TSE
1.4x1.86x3.5 mm
Reduction factor 2.4
6:08 min

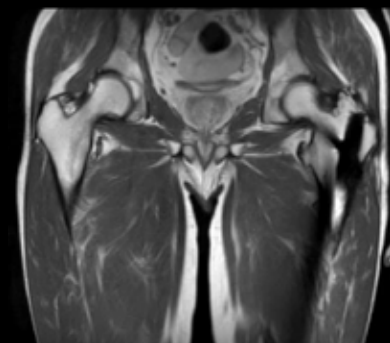

Coronal 2D PDw TSE
1.4x1.86x3.5 mm
Reduction factor 2.4
3:04 min

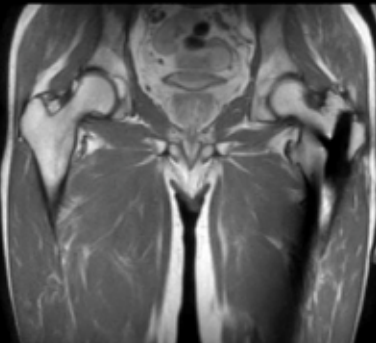

Coronal 2D T1w TSE
0.84x0.97x3.0 mm
Reduction factor 3.0
6:57 min

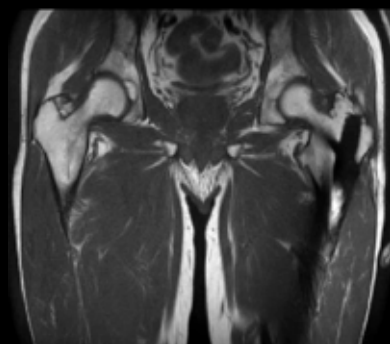

Coronal 2D T1w TSE
0.84x0.97x3.0 mm
Reduction factor 3.0
4:07 min

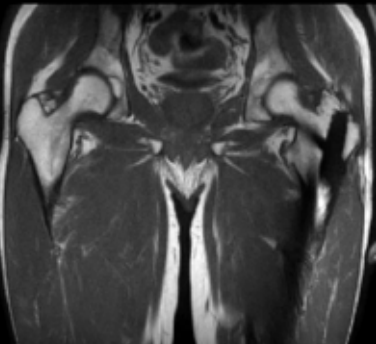

Knee implant - Shorter scan times

Conventional Acceleration



2D PDw TSE
0.80x0.88x3.0 mm
Reduction factor 2.2
6:27 min

Philips SmartSpeed Implant

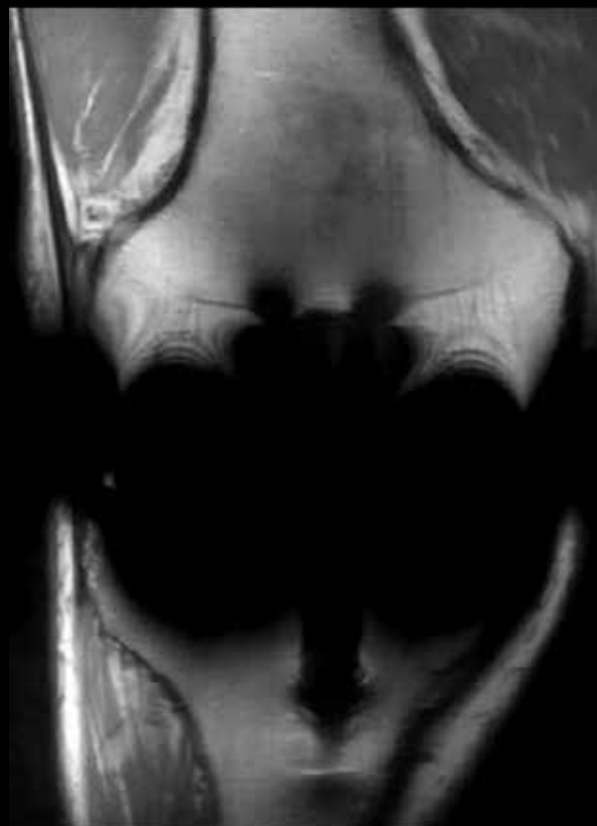

2D PDw TSE
0.80x0.88x3.0 mm
Reduction factor 4.0
3:49 min

Philips SmartSpeed Diffusion: improved image quality for fast diffusion scans

Diffusion weighted imaging (DWI) is used for many applications and is a major sequence for prostate, neuro and liver examinations. Next to the qualitative assessment of diffusion restriction, quantitative information can be used with, for instance the apparent diffusion coefficient (ADC). By nature, DWI scans have a low signal-to-noise ratio (SNR) as the signal has decayed by the applied diffusion encoding gradients. Consequently, in practice, multiple averages are acquired to realize adequate image quality. Since multiple diffusion

directions are involved, for isotropic diffusion three directions are used; each average can take a considerable amount of time. Philips SmartSpeed Diffusion is designed to improve the SNR of individual diffusion-weighted imaging measurements in order to shorten scan times, improve resolution, or reduce the distortion caused by the echo-planar-imaging readout. Next to these acquisition benefits, ADC maps become more reliable as noise biases are reduced.

How is the SNR improvement in Philips SmartSpeed Diffusion realized?

Nowadays all diffusion scans are performed with multiple element coil arrays. The high SNR of such coils allows reduced scan times and the performance of parallel imaging. However, it also comes with the downside that SNR is not equal over the whole FOV with higher noise levels at greater distances from the element loops as the coil sensitivity is lower in these areas. In addition, when parallel imaging is used, g-factor related noise enhancement can occur that depends

on the coil geometry and the applied acceleration factor. Both the g-factor related noise enhancement as well as the coil-related noise distribution are non-sparse in nature. As a result, they fit exactly to a reconstruction scheme that is able to cope with that, hence the Compressed SENSE reconstruction scheme. Philips SmartSpeed Diffusion leverages the Philips SmartSpeed Engine to minimize g-factor and coil sensitivity related noise enhancements.

Which sampling pattern is being used?

In general, diffusion scans are performed with a single shot echo planar imaging (SSh EPI) readout. Consequently, a complete image is acquired after a single diffusion encoding while maintaining sufficient SNR within acceptable echo times.

Therefore, this readout scheme with a regular sampling pattern is also implemented in the Philips SmartSpeed Engine in which the iterative reconstruction effectively reduces the non-uniformly distributed g-factor and coil geometry related noise.

What is the impact of noise on the ADC values?

ADC maps can be generated when at least 2 b-values are acquired, after which a pixel-wise mono-exponential fit over the b-values is performed. SNR differences exist between the various b-values that are being acquired. Often more averages are used for the highest b-values relative to the lower ones, resulting in varying noise levels over the data. Furthermore, in areas with low signal, the modulus operation during image generation will increase pixel values by the

properties of the Rician noise distribution related to it. Consequently, a noise bias in the ADC values will exist in these areas. An example is provided in Figure 11 in which the negative noise bias is shown in a spherical flood field phantom. With the Philips SmartSpeed Diffusion implementation, the noise level is reduced, leading to the minimization of noise bias in ADC values, increasing confidence in the final ADC maps.

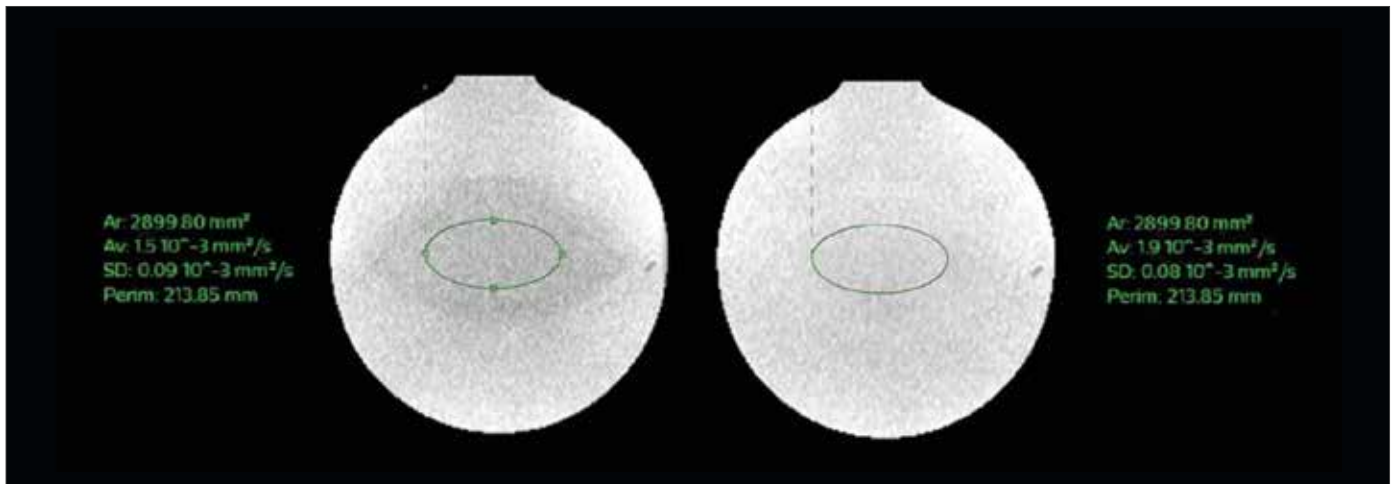

Figure 11: A spherical flood field phantom was used for ADC measurements with acceleration Factor:3. ADC values should be consistent over the phantom as it contains a single fluid. a) SENSE scan in which clearly the g-factor behavior can be recognized in the ADC map. b) Philips SmartSpeed Diffusion scan demonstrates that the coil geometry impact is no longer seen. The ROI shows that the ADC increased from $1.5 \times 10^{-3} \text{ mm}^2/\text{s}$ to $1.9 \times 10^{-3} \text{ mm}^2/\text{s}$, a clear indication of the removal of the noise bias.

What are the clinical benefits of Philips SmartSpeed Diffusion?

Philips SmartSpeed Diffusion can be used to reduce scan time. This is most effectively realized by reducing the number of averages, especially for the higher b-values. Scan time reduction can also be realized by increased acceleration factors, but this is less effective as the single shot EPI readout is inherently fast. In that case, the gain in scan time comes from a shorter repetition time being far less effective than the removal of averages. Nonetheless, higher

acceleration factors can be used to increase the resolution or to reduce distortion. The higher the acceleration factor, the shorter the EPI readout train length will become, resulting in less distortion and a shorter echo time. The latter is beneficial for intrinsic signal and a lower T2 shine-through appearance. The g-factor related noise penalty that normally comes with using higher acceleration factors is effectively mitigated by Philips SmartSpeed Diffusion.

Breast cancer – Receive coil inhomogeneity related noise removal

Conventional Acceleration

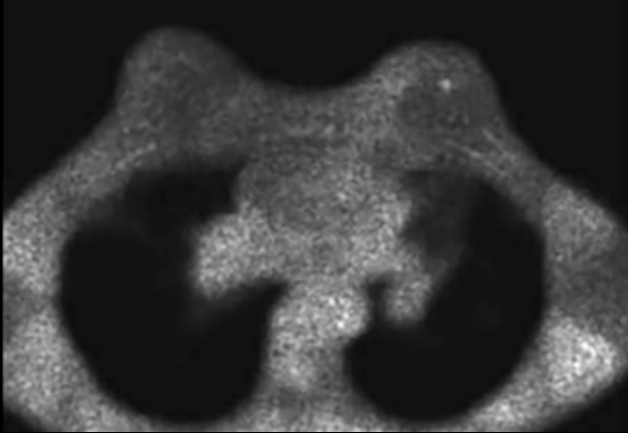

DWIBS b1500
2.34x2.44x3.0 mm
Reduction factor 5.0
1:55 min

Philips SmartSpeed Diffusion

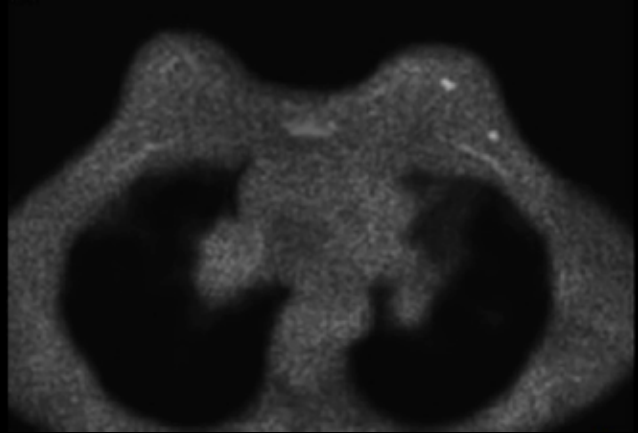

DWIBS b1500
2.34x2.44x3.0 mm
Reduction factor 5.0
1:55 min

Courtesy: Kumamoto University Hospital, Japan. Ingenia CX 3.0T

Liver hepatocellular carcinoma – Higher resolution

Low resolution

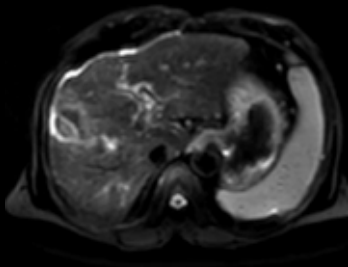

DWI
2.95x2.44x7.0 mm
Reduction factor 2.0
2:18 min

Conventional acceleration

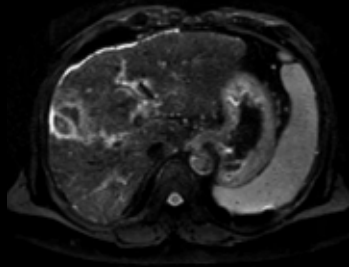

DWI
2.95x2.44x7.0 mm
Reduction factor 2.0
2:18 min

Philips SmartSpeed Diffusion

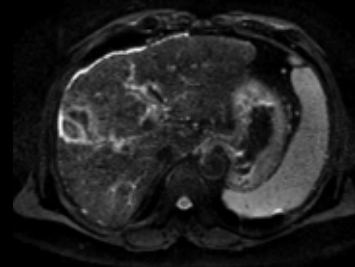

DWI
2.95x2.44x7.0 mm
Reduction factor 2.0
2:18 min

Courtesy: Kumamoto University Hospital, Japan. Ingenia CX 3.0T

Prostate cancer: Reduced scan time

Conventional Acceleration

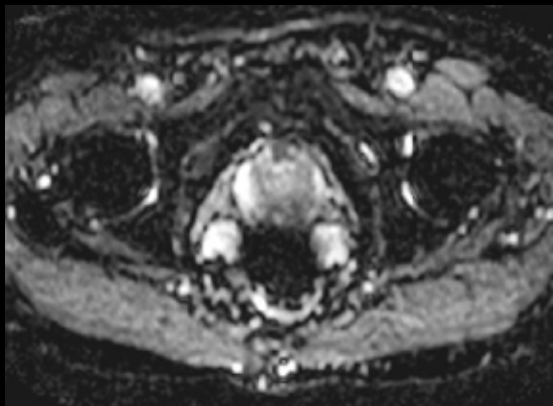

Philips SmartSpeed Diffusion

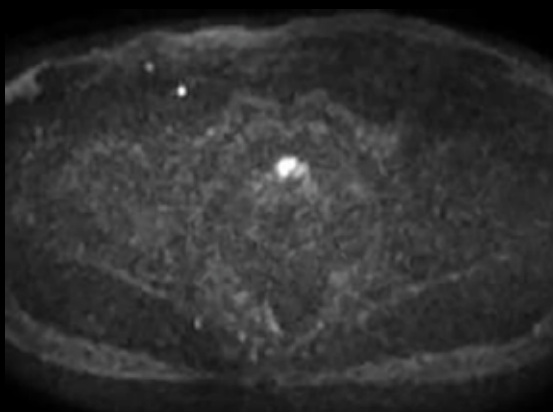
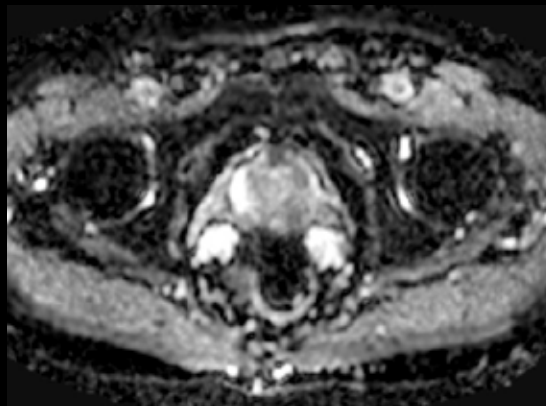

DWI b0 / b2000
2.5x3.14x3.0 mm
Reduction factor
2.0 / 7 NSA
1:46 min

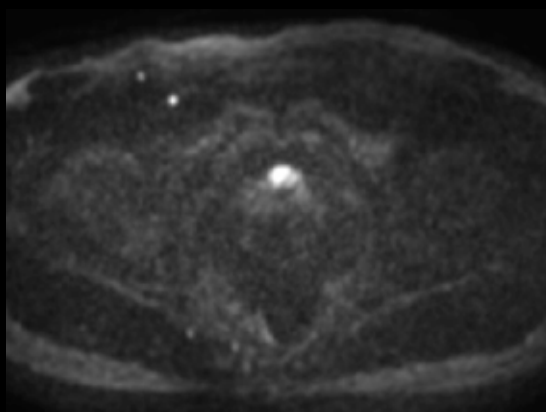

DWI b0 / b2000
2.5x3.14x3.0 mm
Reduction factor
2.0 / 5 NSA
1:17 min

Summary

Philips SmartSpeed brings the next step in MR image acceleration. The unique Philips SmartSpeed Engine builds on Philips' heritage in scan acceleration and leverages the combination of SENSE and Compressed SENSE with award winning AI reconstruction technology. Philips SmartSpeed allows acceleration and improved image quality for many types of acquisitions:

- Cartesian 2D and 3D scans of all contrasts across all anatomies can be accelerated using **Philips SmartSpeed AI**.
- With **Philips SmartSpeed MotionFree** it is now possible to conduct motion robust scanning in the same scan time and with the same contrast as its non-motion-corrected equivalent.
- **Philips SmartSpeed 3DFreeBreathing** accelerates 3D T1w scans, with a focus on robustness to motion, eliminating the need for breath hold.
- **Philips SmartSpeed Implant** is a powerful solution to image in the presence of metallic implants within regular acquisition times.
- Fast, high-quality diffusion images are produced with **Philips SmartSpeed Diffusion**.

In short, Philips SmartSpeed is not just a fast-imaging solution; it improves productivity, enhances diagnostic confidence, and increases patient accessibility with 97% applicability of all types of scans.

References

- 1 Andre JB, Bresnahan BW, Mossa-Basha M, et al. Toward Quantifying the Prevalence, Severity, and Cost Associated With Patient Motion During Clinical MR Examinations. *J Am Coll Radiol*. 2015;12(7): 689-95.
- 2 Kantar. Patient Experience in Imaging Research. 2017. <https://www.philips.com/a-w/about/news/archive/standard/news/press/2017/20171024-philips-announces-findings-of-patient-experience-in-imaging-research.html>.
- 3 Peeters H, et al. Next generation parallel imaging with dS SENSE technology. The Netherlands: Philips Healthcare; 2017 Mar. Report No: 4522 991 13591.
- 4 Geerts-Ossevoort L, de Weerd E, Duijndam A, et al. Compressed SENSE: Speed done right. Every time. Philips Healthcare. 2018.
- 5 Delattre BMA, Boudabbous S, Hansen C, et al. Compressed sensing MRI of different organs: ready for clinical daily practice? *Eur Radiol*. 2020 Jan;30(1): 308-319.
- 6 Sartoretti E, Sartoretti T, Binkert C, et al. Reduction of procedure times in routine clinical practice with Compressed SENSE magnetic resonance imaging technique. *PLoS One*. 2019;14(4): e0214887.
- 7 Dieckmeyer M, Roy AG, Senapati J, et al. Effect of MRI acquisition acceleration via compressed sensing and parallel imaging on brain volumetry. *MAGMA*. 2021 Aug; 34(4):487-497.
- 8 Stutters, J, Battiston M, John N, et al. Structural 3DT1 scans with compressed sensing are suitable for cross-sectional brain volume measures in multiple sclerosis. Proceedings of the International Society of Magnetic Resonance in Medicine 29th annual meeting. 2021, #2150.
- 9 Boyarko AC, Dillman JR, Tkach JA, et al. Comparison of compressed SENSE and SENSE for quantitative liver MRI in children and young adults. *Abdom Radiol (NY)*. 2021 Apr 24. doi: 10.1007/s00261-021-03092-x. Online ahead of print. 10 10 Lohöfer FK, Braren RF, et al. Acceleration of chemical shift encoding-based water fat MRI for liver proton density fat fraction and T2* mapping using compressed sensing. *PLoS One*. 2019; Nov15;14(11):e0224988.
- 11 Sasi SD, Singh A. Evaluating feasibility of high resolution T1-perfusion MRI with whole brain coverage using compressed SENSE: Application to glioma grading. *Eur J Radiol*. 2020; Aug129.
- 12 Mönch S, Hedderich DM. Magnetic Resonance Imaging of the Brain Using Compressed Sensing – Quality Assessment in Daily Clinical Routine. *Clin Neuroradiol*. 2020;30(2):279-286.
- 13 Nam JG, Lee JM, Lee SM, et al. High Acceleration Three-Dimensional T1-Weighted Dual Echo Dixon Hepatobiliary Phase Imaging Using Compressed Sensing-Sensitivity Encoding: Comparison of Image Quality and Solid Lesion Detectability with the Standard T1-Weighted Sequence. *Korean J Radiol*. 2019 Mar; 20(3):438-448.
- 14 Philips. How AI can enhance the human experience in healthcare. 2021. <https://www.philips.com/a-w/about/news/archive/blogs/innovation-matters/2021/20210906-the-power-of-prediction-how-ai-can-help-hospitals-forecast-andmanage-patient-flow.html>.
- 15 Pezzotti N, de Weerd E, Yousefi S, et al. Adaptive-CS-Net: FastMRI with Adaptive Intelligence. arxiv. 2019;(NeurIPS).
- 16 Pezzotti N, Yousefi S, Elmahdy MS, et al. An Adaptive Intelligence Algorithm for Undersampled Knee MRI Reconstruction. *IEEE Access*. 2020; 8:204825-204838.
- 17 Knöll F, Murrell T, Sriram A, et al. Advancing machine learning for MR image reconstruction with an open competition: Overview of the 2019 fastMRI challenge. *Magn Reson Med*. 2020; (January): rm.28338.
- 18 Johnson PM, Jeong G, Hammernik K, et al. Evaluation of the Robustness of Learned MR Image Reconstruction to Systematic Deviations Between Training and Test Data for the Models from the fastMRI Challenge. In: *Machine Learning for Medical Image Reconstruction*. 2021.
- 19 Pipe JG, Motion Correction with PROPELLER MRI: Application to Head Motion and Free-Breathing Cardiac Imaging, 1999, *MRM* 42, 963-969.
- 20 Perkins TG, Duijndam A, Eggers H, et al. mDixon XD: The next-generation fat-free imaging. Philips Healthcare. 2015.
- 21 Hey S, Hoogenraad D, Elanchezian V, et al. Orthopedic Metal Artifact Reduction. Distortion correction in the presence of an orthopedic implant. Philips Healthcare. 2016.
- 22 Van den Brink J, Possanzini C, Van Meel M, et al. Simplify scanning of patients with MR conditional implants. Philips Healthcare. 2016.
- 23 Pruessmann KP, Weiger M, Scheidegger MR, Boesiger P. SENSE: Sensitivity encoding for fast MRI. *Magn. Reson Med*. 1999; 42(5):952-962.

