

Philips
Professional LED LCD TV

42" EasySuite

LED
DVB-T/C MPEG 2/4

42HFL3016D



Impress your guests, with the most efficiency

Philips Hospitality LED LCD TV

With this modern and energy efficient Hospitality Full HD LED LCD TV, you will enjoy all the benefits of digital television. Your guests will enjoy a warm welcome and great viewing experience with this professional hotel TV.

Sustainable and safe

- Low power consumption
- Eco-friendly design and flame-retardant housing
- Green Button allows guest to save even more energy

Differentiating guest experience

- Additional headphone connection for personal listening
- Hotel Scenea for a tailored info and start-up channel
- ThemeTV Lite for easy channel navigation

Advanced hotel features and future proof

- Brilliant LED images with incredible contrast
- MyChoice compatibility for recurring revenues
- Integrated Connectivity Panel
- Full Hotel, Healthcare and Prison Modes
- Installation menu locking

PHILIPS

Highlights

Hotel, Hospital, Prison Mode

All required features for professional use in environments where more is required than in a living room. From volume and menu locking to more rigorous material testing, energy saving, anti-theft remote controls and dedicated Healthcare and Prison features to allow for niche market applications.

MyChoice compatible



MyChoice offers a simple and low-cost way to offer your guests premium TV channels. At the same time it delivers an additional revenue stream which allows you to recover your initial TV investment.

ThemeTV Lite

ThemeTV Lite offers an easy user interface that gives your guests the opportunity to navigate the guest menu to find channels from their home country, news and hotel information easily without the need for an interactive entertainment system.

Hotel Scenea

Hotel Scenea allows you to select and store images on the TV that can be displayed as a start-up or info channel.

Integrated Connectivity Panel

The Integrated Connectivity Panel allows your guests to seamlessly connect their personal devices to your TV without the need for an external Connectivity Panel.

Low power consumption

Philips TVs are designed to minimise power consumption. This will not only reduce environmental impact but also lower operating costs.

Green Button

With the Green Button guests have the option to save even more energy on the TV by opting for a higher backlight dimming or by switching off the screen when listening to radio. Another way to reduce a hotel's operating costs while involving guests directly.

Installation menu locking

Prevents unauthorised access to installation and configuration settings, to ensure maximum guest convenience and avoid unnecessary reprogramming costs.

Eco-friendly design

Sustainability is integral to the way Philips does business. Philips TVs are designed and produced according to our EcoDesign principles aimed at minimising overall environmental impact, through lower power consumption, removal of hazardous substances, lower weight, more efficient packaging and better recyclability. Philips TVs also have a special housing of flame-retardant material. Independent tests carried out by

emergency fire services have shown that whereas TVs can sometimes intensify fires caused by external sources, Philips TVs will not contribute to a fire.

Headphone connection

This speaker system features an additional headphone connection. Connect your own headphones for a more personal listening experience whenever you want it.

Full HD LED TV



The most advanced LED lighting technology in this Full HD LED TV combines an eye-catching minimalistic design with stunning image quality as well as the lowest power consumption in its category. On top of that, LED lighting technology does not contain any hazardous materials. Thus, with LED backlights you can enjoy low power consumption, high brightness, incredible contrast, sharpness and vibrant colours.

Specifications

Picture/Display

- Aspect ratio: 16:9
- Diagonal screen size (inch): 42 inch
- Diagonal screen size (metric): 107 cm
- Colour cabinet: Black
- Display: LED Full HD
- Panel resolution: 1920 x 1080p
- Brightness: 400 cd/m²
- Picture enhancement: Digital Crystal Clear, 100 Hz Perfect Motion Rate
- Dynamic screen contrast: 100,000:1

Supported Display Resolution

- Computer inputs: up to 1920 x 1080 @ 60 Hz
- Video inputs: 24, 25, 30, 50, 60 Hz, up to 1920 x 1080p

Tuner/Reception/Transmission

- Digital TV: DVB-C MPEG2*, DVB-C MPEG4*, DVB-T MPEG2*, DVB-T MPEG4*
- Video Playback: NTSC, PAL, SECAM

Multimedia Applications

- Multimedia connections: USB
- Video Playback Formats: H264/MPEG-4 AVC, MPEG-1, MPEG-2, MPEG-4
- Music Playback Formats: MP3
- Picture Playback Formats: JPEG

Convenience

- Ease of Installation: Advanced Hotel Mode, Auto Programme Naming, Automatic Channel Install (ACI), Automatic Tuning System (ATS), Autostore, Cloning of TV settings via RF, Cloning of TV settings via USB
- Ease of Use: 1 channel list analogue/digital, On-Screen Display, Programme List, Side Control
- Comfort: Hotel Guest features, Sleep timer, Switch on channel, Volume limitation, Welcome message
- Screen Format Adjustments: 4:3, Movie expand 14:9, Movie expand 16:9, Subtitle Zoom, Super Zoom, Widescreen
- Electronic Programme Guide: 8-day Electronic Programme Guide, Now + Next EPG
- Remote Control: battery anti-theft protection, low battery detection
- Interactive hotel features: Block automatic channel update, Block over-the-air SW download,

MyChoice, ThemeTV Lite

- Remote control type: 22AV1104D (RC6)
- Prison mode: Txt, MHEG, USB, EPG, Sub block
- Teletext: 1000-page Smart Text
- Other convenience: Kensington lock
- Firmware upgradeable: Firmware upgradeable via USB, Firmware upgradeable via RF

Healthcare

- Control: Multi remote control
- Safety: Double isolation Class II
- Convenience: Headphone out, Independent main speaker mute

Sound

- Output power (RMS): 20 W (2 x 10 W)
- Sound Enhancement: Auto Volume Leveller, Clear Sound, Incredible Surround

Loudspeakers

- Built-in speakers: 2

Connectivity

- Number of AV connections: 1
- Number of HDMI connections: 3
- HDMI features: Audio Return Channel
- Number of components in (YPbPr): 1
- EasyLink (HDMI-CEC): Remote control pass-through, System audio control, System standby, One touch play
- Number of scarts (RGB/CVBS): 1
- Number of USBs: 1
- Other connections: Antenna IEC75, Common Interface Plus (CI+), PC-in VGA + Audio L/R in

Power

- Mains power: 220-240 V; 50 Hz
- Ambient temperature: 5°C to 35°C
- Standby power consumption: $\leq 0.3\text{ W}$
- Power consumption (typical): 62 W
- Energy Label Class: A
- Power Saving Features: Eco mode, Picture mute (for radio)
- Off mode power consumption: ≤ 0.3
- Annual energy consumption: 91 kW h

Green Specifications

- Low Power Standby

Accessories

- Included accessories: Power cord, Remote Control, Tabletop stand, Warranty Leaflet, Batteries for remote control
- Optional accessories: Set up remote 22AV8573/00, Wall mount (tilt) 22AV3100/10

Dimensions

- Set Width: 977.2 mm
- Set Height: 589 mm
- Set Depth: 42.9 mm
- Product weight: 12.9 kg
- Set width (with stand): 977.2 mm
- Set height (with stand): 628.7 mm
- Set depth (with stand): 210 mm
- Product weight (+stand): 15.3 kg
- Box width: 1205 mm
- Box height: 702 mm
- Box depth: 160 mm
- Weight incl. Packaging: 18.7 kg
- Compatible wall mount: 400 x 400 mm

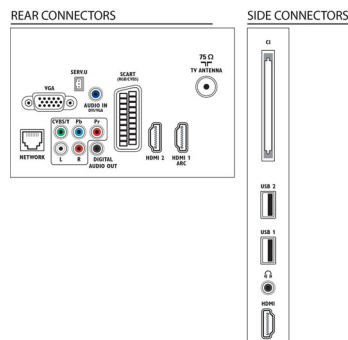

Issue date 2024-03-24

Version: 3.1.3

EAN: 87 12581 65376 7

© 2024 Koninklijke Philips N.V.
All Rights reserved.

Specifications are subject to change without notice.
Trademarks are the property of Koninklijke Philips N.V.
or their respective owners.

www.philips.com