

PHILIPS

EasyKey

7000 series

Facial recognition
smart door lock

DDL709-FVP-7HWS

User manual

Sign your product up and get
support at
www.philips.com/support



Contents

1. Important Information	02	6. Other features	19
Safety		Indoor infrared unlock	
Caution		Outside forced lock	
Disposal of used products and batteries		Mute button	
		Default settings	
		Doorbell	
		Video intercom	
		Display	
2. Assembly	03		
Packing list			
Exploded views			
Notice before assembling			
Adjustable latch instructions			
Assembly procedure			
3. Get to know your smart lock	09	7. Indicators	21
Outside escutcheon		Door lock status indicator	
Inside escutcheon		Low battery indicator	
		Outside forced lock indicator	
		Mute indicator	
		Indoor deadlock indicator	
		System locking indicator	
4. Settings	10	8. Troubleshooting	22
Instructions before setting		Alert types	
Master mode		How to apply external power supply	
User settings		Battery replacement	
Settings		Battery recharge	
Network settings			
App binding guidance			
Cloud Storage Usage Guide			
5. Get to use your lock	16		
Outdoor/ indoor unlock			
Outdoor/ indoor lock			
Inside deadlock			
Mechanical key unlock			

1. Important information

Safety

- ◆ Before using the product, please read through and fully understand all instructions. The warranty will not cover damage caused by non-observance to the instructions.
- ◆ Suggest using only the manufacturer-specified accessories / components.
- ◆ Use only the alkaline or Li-polymer batteries the product is equipped with or use the same type of batteries with the same specification.
- ◆ Do not forcibly disassemble the product to avoid triggering the alert or damaging the product.
- ◆ Do not use any sharp object to scratch the fingerprint sensor, otherwise, it might cause permanent damage.
- ◆ Do not expose products to places that have water leakage or splashing.
- ◆ Do not expose the product to corrosive substances to prevent damaging the protective cover.
- ◆ Do not hang objects on the handle in case it might affect the normal use of the lock.
- ◆ Please clean the product with soft cloth.
- ◆ Do not disassemble the battery during setting up and operating.
- ◆ Please follow the assembly instructions that we provided to install the product and keep the relevant sealed stickers properly.
- ◆ Please modify the default master PIN code immediately after installation and configuration are done, and keep the mechanical key properly, do not disclose the PIN codes to others.
- ◆ Please replace all the batteries in time if there is a low battery alert. Please make sure to match the poles (+/-) correctly when installing the batteries.

Caution

- ◆ Do not place the batteries near ignition source to avoid explosion.
- ◆ Do not use any power supply that does not meet the safety requirements to power up the product.
- ◆ Do not connect the 2 poles of the batteries with metals to avoid short out which may lead to explosion.
- ◆ Please make sure any component replacement is executed by Philips, Philips authorized service centers or professional technicians.
- ◆ Do not use accessories or parts that have been produced by other manufacturers or have not been specifically recommended by Philips. The use of such accessories and parts may void your warranty.

Disposal of used products and batteries

- ◆ You can have your locks reclaimed at Philips authorized service centers. You will receive corresponding compensation if your products meet our recall conditions.
- ◆ Please familiarize with the local electronic product collection system yourself.
- ◆ Please follow local regulations and do not discard used products and batteries into ordinary household waste.
- ◆ Please familiarize with the local regulations on batteries classification recycling yourself. Disposing of used products and batteries properly can help avoid a negative impact on the environment and human health.

2 Assembly

Packing list

This packing list is for reference only. Please refer to the actual packing items.

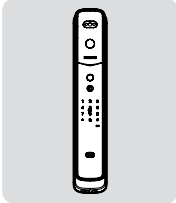

① Outside escutcheon with silicon pad

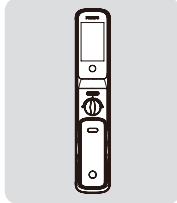

② Inside escutcheon with silicon pad

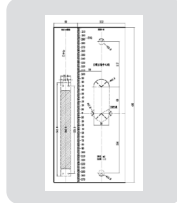

③ Drilling template

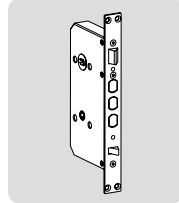

④ Mortise

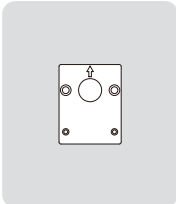

⑤ Fixing plate



⑥ QSG

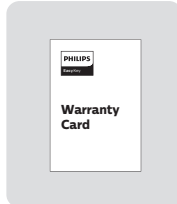

⑦ Warranty card



⑧ Certificate of conformity

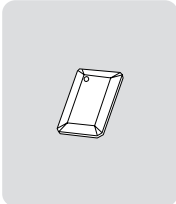

⑨ Key tag

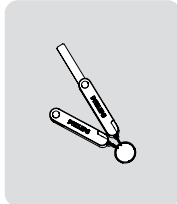

⑩ Mechanical keys

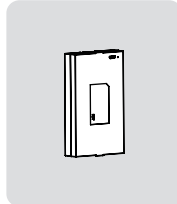

⑪ Li-Polymer battery

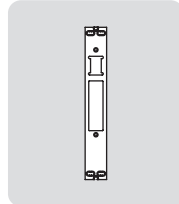

⑫ Strike plate

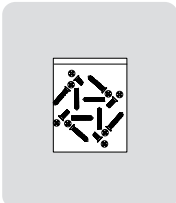

⑬ Installation kit

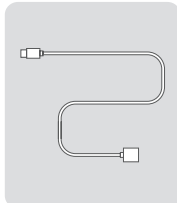

⑭ Charging cable

Exploded views

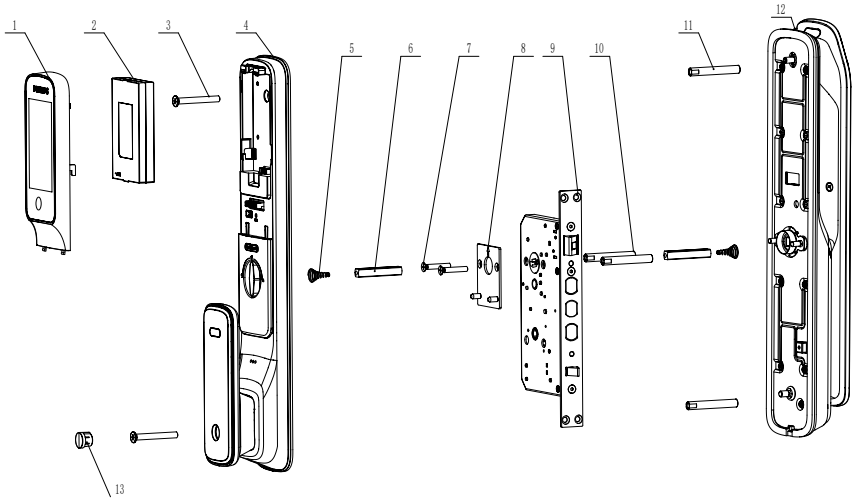

1. Battery cover*1

2. Li-polymer battery*1

3. M6 anchor screw*2

4. Inside escutcheon*1

5. Compressed spring*2

6. Square shaft*2

7. M5 anchor screw*2

8. Fixing plate*1

9. Mortise*1

10. M5 screw tube*2

11. M6 screw tube*2

12. Outside escutcheon*1

13. Screw plug*1

Notice before assembling

This product applies to doors with four opening directions: left-hand inswing, left-hand outswing, right-hand inswing, and right-hand outswing.

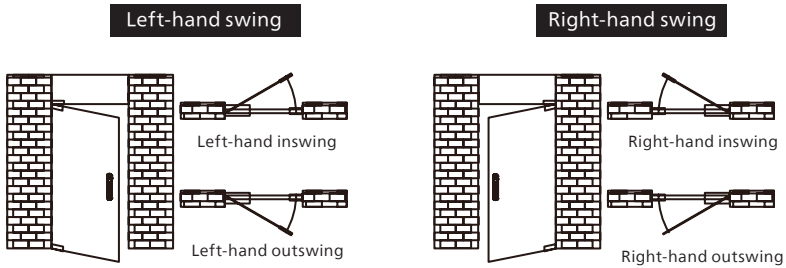

⚠ Attention

1. Choose a proper installation kit based on the door thickness.
2. The default tool kit applies to a door thickness of 60-90mm. Please consult the local distributor for other door thicknesses.

Adjustable latch instructions

1. Loosen the screws counterclockwise with an Allen wrench and remove the mortise plate.
2. Pull the latch straight out of mortise, turn the latch 180 degrees, and reinsert it into the mortise.

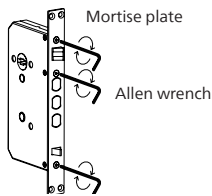

3. Reattach the mortise plate on the mortise and tighten the screws with the Allen wrench.

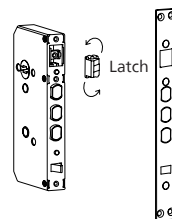
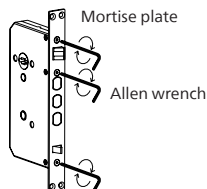

Assembly procedure

The following assembly procedure applies to the right-hand swing doors. For left-hand swing doors, please read through the [Notice before assembling] and complete the adjustable latch instructions.

- 1 To drill holes in the door according to the drilling template, mount the mortise into the jamb, and tighten the four anchor screws.

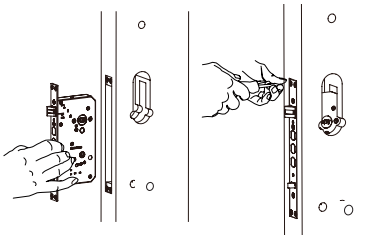

⚠ Attention

Please make sure the dead bolt are retracted during assembly.

- 2 Attach the connecting screw tube on the outside escutcheon and put the compressed spring and square shaft in the square shaft hole accordingly.

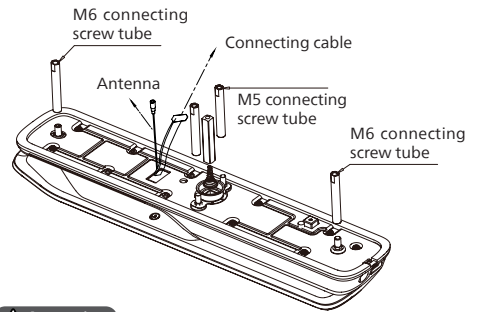

⚠ Attention

Please choose the appropriate length of the square shaft and screw tube according to the door thickness.

- 3 Pass the connecting cable through the hole, align and insert the square shaft of the outside escutcheon into the rotary hole, so that the outside escutcheon is tight against the outside of the door.

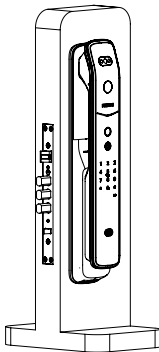

- 4 Fasten the fixing plate to the inner surface of the door and use two M5 connecting screws to secure it tightly.

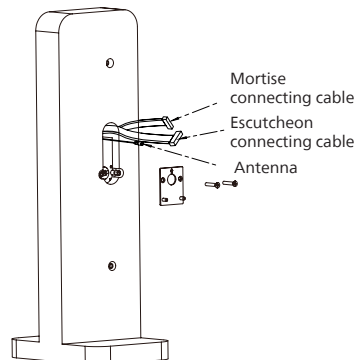

- 5 Put the compressed spring and square shaft on the inside escutcheon accordingly.

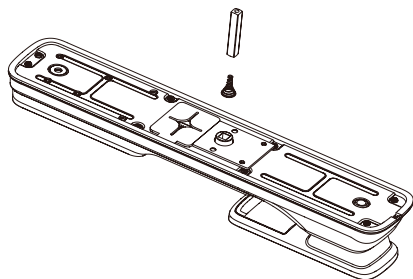

- 6 Insert the escutcheon connecting cables and mortise connecting cables into the corresponding socket of the inside escutcheon, then connect the antenna, and align the square shaft hole on the inside escutcheon against the rotary hole on the mortise, so that the inside escutcheon is closely attached to the inner surface of the door.

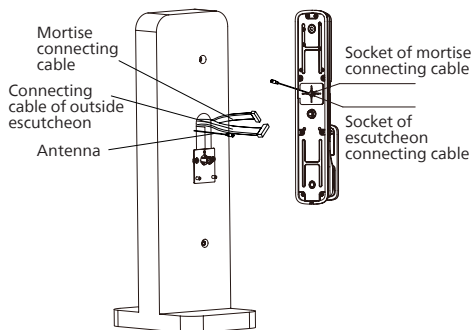

Attention

Be sure to put the escutcheon connecting cables and the mortise connecting cables into the slot on both sides of the square shaft, and hide the extra cables in the door hole or inside escutcheon.

- 7 Open the upper decorative cover and the battery cover, mount, and tighten the M6 anchor screws to secure the inside escutcheon.

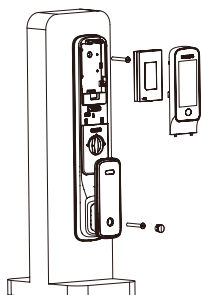

- 8 Install the battery and put the battery cover back, then mount the upper decorative cover and install the strike plate to finish the assembly.

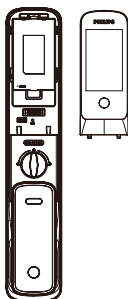

- 9 Check the rotary knob, the mechanical key, and whether each part is connected and assembly in good condition.

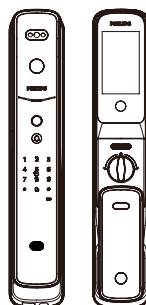

Attention

After installing the strike plate, please test to see if the door opens and closes smoothly.

3 Get to know your smart lock

This packing list is for reference only. Please refer to the actual packing items.

Outside escutcheon

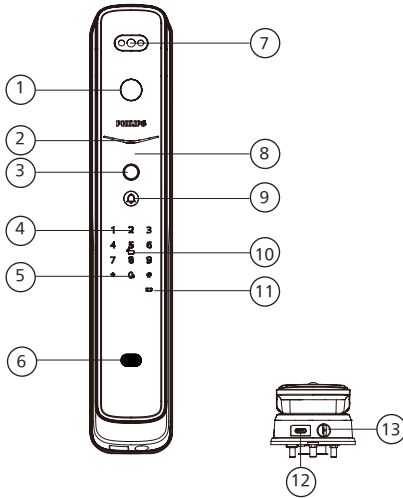

①	Camera
②	Indicator
③	Fingerprint sensor
④	Keypad
⑤	Mute button
⑥	Ultrasound sensor
⑦	Facial recognition module
⑧	Push-pull handle
⑨	Doorbell button
⑩	Card reader
⑪	Low battery indicator
⑫	Reset and external power supply interface
⑬	Mechanical key hole

Inside escutcheon

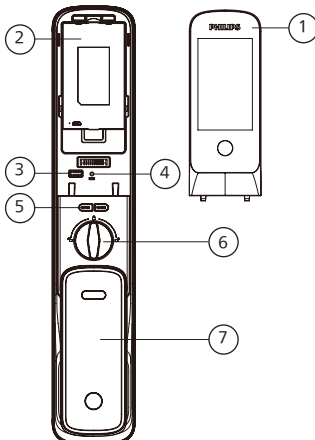

①	Display
②	Battery compartment
③	Application programming interface
④	Reset button
⑤	OPEN/CLOSE button
⑥	Rotary knob
⑦	Push-pull handle

4 Settings

Instructions before setting

- ◆ The system mode is divided into general mode and dual-verification mode.

General mode	Any enrolled access methods can unlock the door
Dual verification mode	Any two enrolled access methods among PIN code, key tag, fingerprint, and face ID can unlock the door

- ◆ User code

You can delete a user's information by its user code without having to delete everything. You can record the user information in the following table for future queries.

User code	Name	Fingerprint	PIN code	Key tag	Face ID
00					
01					
02					
03					
04					
05					
06					
07					
08					

- ◆ Icon annotation

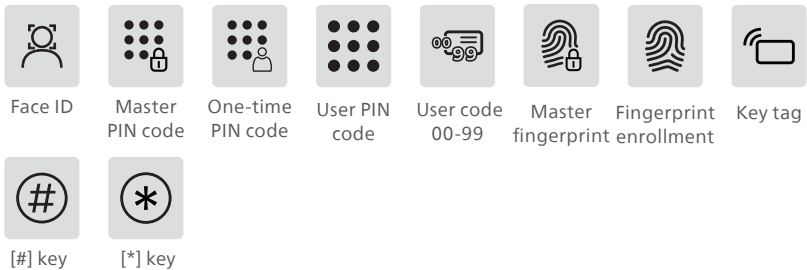

⚠ Attention

1. Press [*] key to return to the previous menu.
2. The default master PIN code is 12345678.

Master mode

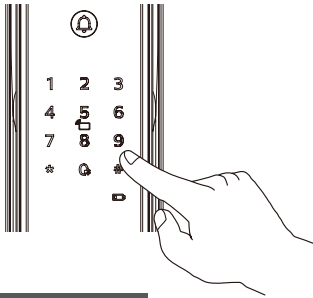

Master PIN code

After lighting up the keypad, press [*] twice before entering other numbers, then enter the master PIN code and confirm with [#], then you are in master mode.

⚠ Attention

If the master PIN code is the initial PIN code, you will need to enter [1] and then [5] in the master mode to modify the master PIN code before you can perform other operations.

Master fingerprint

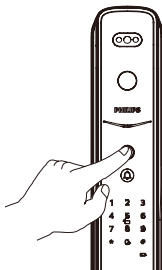

After lighting up the keypad, press [*] twice before entering other numbers, then place your enrolled master fingerprint on the fingerprint sensor to enter master mode.

⚠ Attention

1. Please enroll a master fingerprint before using the product.
2. Please do not set the master fingerprint and user fingerprint with the same finger.

User settings

Add a user PIN code



Press [*] twice, enter the master PIN code, and then press [#] to confirm.



Press [1] to enter user settings, and then press [1] to add a user, the door lock will automatically recognize the corresponding access method and add PIN codes, fingerprints, and key tags directly.



Add a user PIN code: Enter a new user PIN code, and press [#] to confirm, then re-enter the user PIN code and confirm with [#] again. After the voice prompt of "succeeded", press [*] to back to the previous menu until exit the master mode.

Add a user fingerprint: Place the finger on the fingerprint sensor, and you will hear a voice prompt of "please remove your finger and place it on the sensor again", take your finger off and put it back again, repeat several times until you hear a voice prompt of "succeeded", then press [*] to return to the previous menu until you exit the master mode.

Add a user key tag: Enroll a new key tag, when you hear a voice prompt of "succeeded", press [*] to back to the previous menu until you exit the master mode.

Add a one-time PIN code



Press [*] twice, enter the master PIN code, and then press [#] to confirm.



Press [1] to enter user settings, then press [2] to add a one-time PIN code.



Enter a 6-12 digits one-time PIN code, and press [#] to confirm; enter the one-time PIN code again, and confirm with [#]. After the voice prompts "added succeeded", press [*] to return to the previous menu until you exit the master mode.

Add a Face ID



Press [*] twice, enter the master PIN code, and then press [#] to confirm.



Press [1] to enter user settings, then press [3] to add a Face ID.



Position your face in front of the camera and gently move your head in different angles by following the voice prompt. After hearing a voice prompt of "succeeded", press [*] until you finally exit the master mode.

Add or change a master fingerprint



Press [*] twice, enter the master PIN code, and then press [#] to confirm.



Press [1] to enter user settings, then press [4] to add or change a master fingerprint.



With no enrolled master fingerprint: Enroll a new user fingerprint, and the new fingerprint will be set as the master fingerprint. After a voice prompt of "succeeded", press [*] to back to the previous menu until you exit the master mode.

With existed master fingerprint : Enter a new user fingerprint, and the new fingerprint will cover the old master fingerprint. After a voice prompt of "succeeded", press [*] to back to the previous menu until you exit the master mode.

Modify master PIN code



Press [*] twice, enter the master PIN code, and then press [#] to confirm.



Press [1] to enter user settings, then press [5] to modify master PIN code.



Enter a new master PIN code and confirm with [#]. Enter the new master PIN code again and confirm with [#]. Once heard a voice prompt of "succeeded", press [*] until you exit master mode.

Delete a user



Press [*] twice, enter the master PIN code, and then press [#] to confirm.



Press [1] to enter user settings, then press [6] to delete user's information.



Select the access methods that need to delete: to delete a PIN code, please press [1]; to delete a fingerprint, please press [2]; to delete a key tag, please press [3]; to delete a Face ID, please press [4]; to delete all user's information, please press [5], for the specific access methods that need to delete, please follow the voice prompt to operate. After the voice prompts deletion succeeded, press [*] to return to the previous menu until you exit the master mode.

Settings

Language settings



Press [*] twice, enter the master PIN code, and then press [#] to confirm.



Press [2] to enter system settings, then press [1] to enter language settings.



Select the language needed: for Chinese, please press [1]; for English, please press [2]. After the voice prompts "setting succeeded", press [*] to return to the previous menu until you exit the master mode.

Attention

The default language is English.

Volume settings



Press [*] twice, enter the master PIN code, and then press [#] to confirm.



Press [2] to enter system settings, then press [2] to enter volume settings.



Select the volume needed: press [1] for higher volume; press [2] for lower volume; press [3] for mute mode. After the setting is done, press [*] to back to the previous menu until you exit the master mode.

Attention

The default volume is higher volume.

Eco settings



Press [*] twice, enter the master PIN code, and then press [#] to confirm.



Press [2] to enter system settings, then press [3] to enter Eco settings.



Press [1] to turn on/off video; press [2] to turn on/off facial recognition; press [3] for sensor settings. After the voice prompts the operation is done, press [*] until you exit the master mode.

⚠ Attention

The Eco mode is disabled by default.

Dual-verification mode



Press [*] twice, enter the master PIN code, and then press [#] to confirm.



Press [2] to enter system settings, then press [4] to enable/disable dual-verification mode. After the voice prompts the operation is done, press [*] until you exit the master mode.

⚠ Attention

The default verification mode is general mode.

Infrared handle



Press [*] twice, enter the master PIN code, and then press [#] to confirm.



Press [2] to enter system settings, then press [5] to enable/disable the infrared handle. After the voice prompts the operation is done, press [*] until you exit the master mode.

⚠ Attention

The infrared handle is enabled by default.

Network configuration

Join a network



Press [*] twice, enter the master PIN code, and then press [#] to confirm.



Press [4] to enter network configuration and it will exit the master mode automatically once the configuration is done.

App binding guidance

① Download

Please scan the QR code below to download Philips EasyKey Plus APP on your phone.



② Add a door lock

Scan QR code

1. After powering up the door lock, find the QR code on the back of the battery cover.
2. Open the "Philips EasyKey Plus" APP, and click [Add a Device] on the home page.
3. After scanning the QR code on the battery cover, follow the instructions of the APP to complete the binding process.

Manually adding the device

1. Enter the "Philips EasyKey Plus" APP, and click [Add a device] on the home page.
2. Search for the current door lock model and enter the binding process.
3. Press [*] twice on the lock, enter the master PIN code, and press [#] to confirm, then the door lock will be in master mode. Press [4] to "Join a network", and the voice prompts "binding, please wait".



- ③ Go back to the APP and follow the prompt to finish the binding process.

⚠ Attention

The door lock only supports 2.4G band Wi-Fi routers (5G band is not supported). Please ensure the distance between the router and the door lock is less than 10 meters, otherwise the Wi-Fi signal might be weak.

Cloud Storage Usage Guide

Philips Cloud Storage Service allows you to store real-time recorded videos from the door lock in the cloud, which can be accessed for playback anytime via the cloud.

Here's a guide to help you understand and make the most of cloud storage (need to bind the door lock in the app first):

- ① Open the Philips Easykey Plus app and go to the "All Devices" or "Smart Lock" tab on the homepage. Select the corresponding model of your smart door lock.
- ② Tap on the "Check it out" or "Learn more" button on the cloud storage introduction page to learn more.
- ③ Copy and paste the URL: <https://easykey.conex-global.com> into your browser to enter the store.
- ④ Click on the "PROTECT PLANS" in the navigation bar to access the purchase page and select a desired subscription plan.
- ⑤ Follow the on-screen prompts to make the payment. After the payment is completed, check your order payment information and activation QR code via email.
- ⑥ Return to the homepage, tap on the "+" icon in the top right corner and scan the activation QR code. Select the device you want to use the subscription plan with and click "Confirm".

5 Get to use your lock

Outdoor/ indoor unlock

Outdoor unlock

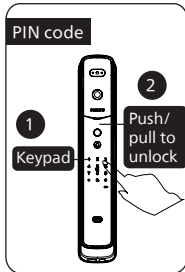

① Touch to wake up the keypad, enter the enrolled PIN code and confirm with [#].

② After the voice prompts "door opened", push or pull the handle to unlock the door.

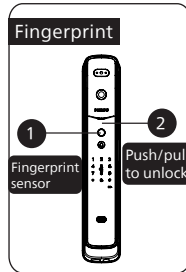

① Place the enrolled finger on the fingerprint sensor.

② After the voice prompts "door opened", push or pull the handle to unlock the door.

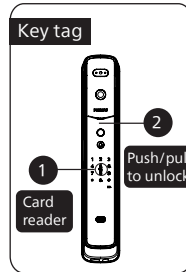

① Place the enrolled key tag on the card reader.

② After the voice prompts "door opened", push or pull the handle to unlock the door.

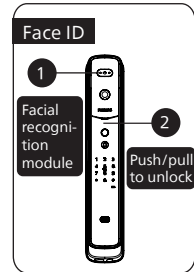

① Face the camera with the enrolled face ID.

② After the voice prompts "door opened", push or pull the handle to unlock the door.

Indoor unlock

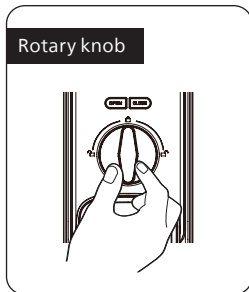

Use the rotary knob to unlock.

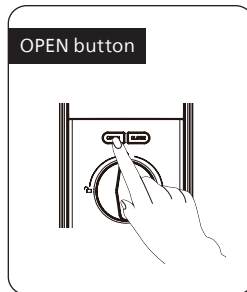

Double press the [OPEN] button within one second, and then push or pull the door to unlock the door.

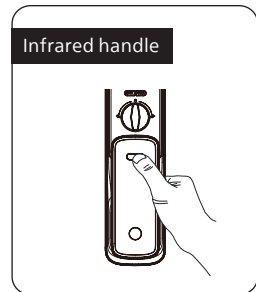

With the infrared sensor on, once the sensor detects the hand from the handle's front and rear side, touching the handle could unlock the door.

Outside/Inside locking

After closing the door, the latch bolt will automatically pop up to lock, and there will be a voice prompts "Door closed".

Inside deadlock

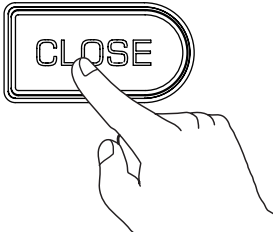

After the door is locked, long press the [CLOSE] button, and there will be a voice prompt of "Inside deadlock enabled".

⚠ Attention

1. In inside deadlock mode, all functionalities from the outside escutcheon will be disabled. With any enrolled access method input from the outside escutcheon, the keypad will display the combination of "15937(X)" followed by a voice prompt of "Inside deadlock enabled" to remind you that the door has locked from inside.
2. In the inside deadlocked mode, unlocking from the outside can only be achieved by entering the master PIN code or using the mechanical key.

Mechanical key

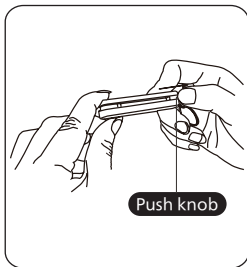

① Cut the mechanical key box and take out the key shell. Push the knob aside and reveal the key itself.

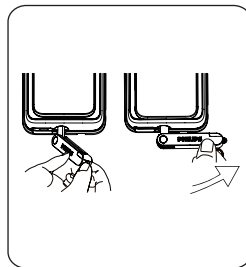

② Insert the key into the key hole and keep the key and key shell vertical to each other. Rotate the key shell towards the handle for 90° until it becomes close to the door surface.

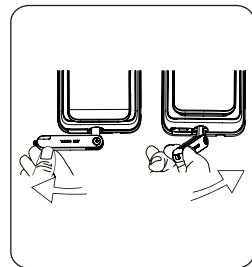

③ Rotate the key cell 180° downward so it can be parallel to the ground, then rotate it horizontally toward the lever to unlock the lock.

⚠ Attention

Please use the mechanical key to unlock the door for emergencies only, i.e. when the battery is dead, when you forgot the PIN code, or the lock fails to work.

6 Other features

Indoor infrared unlock

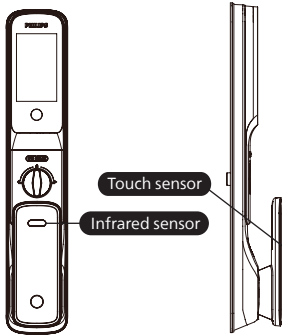

⚠ Attention

When the infrared handle is off, you will not be able to unlock the door from inside. When your hand touches the touch sensor and the infrared sensor, the red light will light up to remind you that the infrared handle is off.

Function:

When this function is enabled, you could unlock the door from inside.

How to use:

When the touch sensor and infrared sensor are on, touching the touch sensor and infrared sensor on the handle can unlock the door.

Infrared handle:

When the infrared handle is off, long pressing the [OPEN] and [CLOSE] buttons for 10 seconds can enable the infrared handle.

When the infrared handle is on, long pressing the [OPEN] and [CLOSE] buttons for 10 seconds can disable the infrared handle.

Outside forced lock

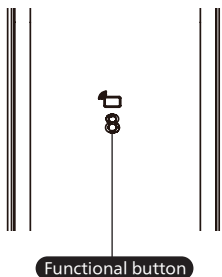

Function:

Unlocking from inside will trigger an alert.

How to use:

After the door is locked, press [8] to enter the outside forced lock mode.

⚠ Attention

The outside forced lock mode will not affect the normal unlocking from outside.

Mute button

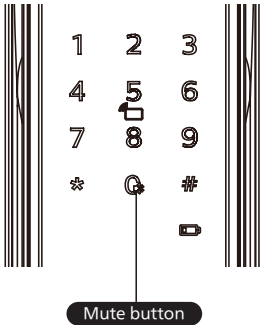

Function:

Press [0] to enable mute mode when before unlocking the door, this function applies to scenarios in which you don't want to disturb your family.

How to use:

Mute: when the outside escutcheon is light up, press the [mute button] for 2 seconds to enter mute mode, it will follow by a voice prompt of "mute mode enabled".

Unmute: when the outside escutcheon is light up, press the [mute button] for 2 seconds to restore to voice guide, it will follow by a voice prompt of "voice prompt enabled".

Default settings

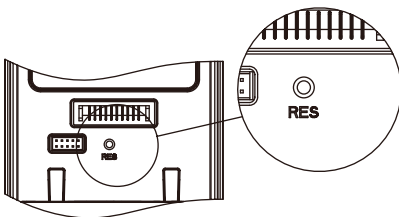

Function:

To empty all user information and restore to default settings.

How to use:

Double press the [RES] button with a sharp object, and all the user information will be emptied. The lock will restore to default settings.

Doorbell

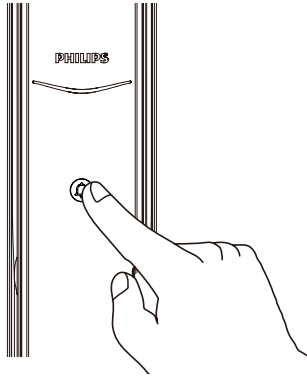

Function:

The indoor speaker emits a ding-dong sound to remind the host that a visitor has arrived.

How to use:

Press the doorbell from outside, the indoor speaker will emit a ding-dong sound. Simultaneously, the camera of the door lock will capture the visitor's photo, and send the captured content to the bond APP. After the APP receives the push message, you can remotely view the captured content of the doorway and unlock the door accordingly.

⚠ Attention

After pressing the doorbell, the smile curve will flash in blue.

Video intercom

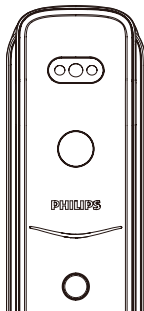

Function:

You can view the doorway situation and realize real-time two-way intercom via video function on the APP.

How to use:

After the door lock bond to the APP, you can view the doorway situation and realize real-time two-way intercom via video function and unlock the door accordingly.

Display

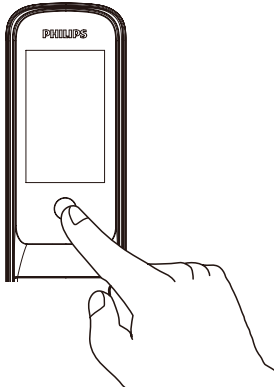

Function:

When the visitor rings the doorbell, users can check the doorway from the indoor display.

How to use:

1. When a visitor rings the doorbell, the indoor display will be on. Click the indoor screen button to turn on the display, and you can also view the doorway through the screen.
 2. Users can set the display duration and screen brightness via APP.
-

7 Indicators

Status indicator

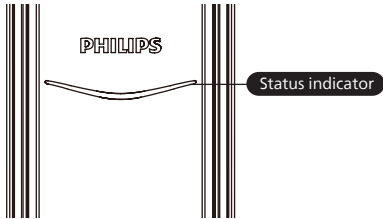

Blue: When the system wakes up, the indicator will turn blue, indicating that the door lock can be processed and operated;

Green: When the door lock is unlocked, the indicator will turn green, indicating that the door has opened;

Red: When the door lock is locked, the indicator will turn red, indicating that the door has closed.

Low battery level indicator

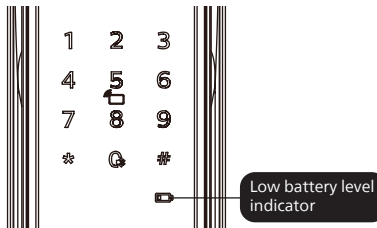

Red: When the door lock system wakes up, the battery voltage will be automatically detected. If the voltage is too low, the indicator will flash in red. When the lock is unlocked, there will be a voice prompt indicating that the battery level is low, please replace the battery in time.

Outside forced lock indicator

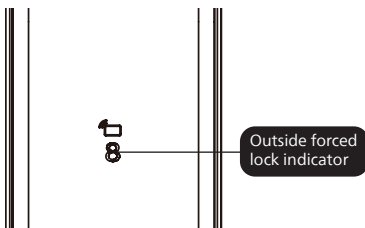

White: When the door lock is locked, the digit "8" lights up alone, indicating that the outside forced lock mode can be activated.

Indoor deadlock indicator

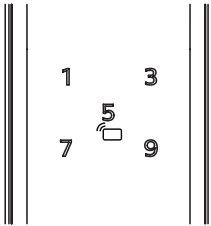

In indoor deadlock mode, the digital functions of the outside escutcheon will be disabled. After waking up that system manually, the keypad will show the combination of "15937 (X)", and follow by a voice prompt indicating that the inside deadlock is enabled.

System-locking indicator

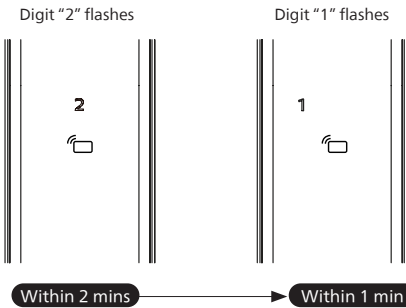

The door lock will be locked for 100 seconds if there are 5 consecutive incorrect inputs among any of the 3 types of access methods (fingerprint, PIN code, or key tag) within 5 minutes.

⚠ Attention

Only when touching to wake up the keypad or verifying the access methods will the system appears such a system-locking prompt.

8 Troubleshooting

Alert types

Outside forced lock mode

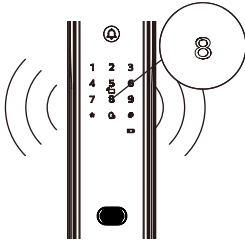

Triggering: If the lock is under outside forced lock mode, unlocking from inside will trigger the alert.

Alert mode: Continuously repeated alert.

Off: The alert will be off by any access verification method.

Low battery alert

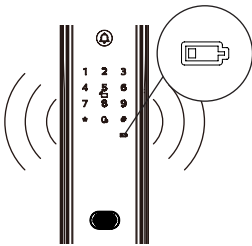

Triggering: When the system wakes up, the battery voltage will be automatically detected. If the battery voltage is insufficient, an alert will be triggered to remind you to replace the battery.

Alert mode: A voice prompt of “Low battery, please replace the battery” during unlocking.

Off: The alert will turn off automatically.

Anti-dismantling alert

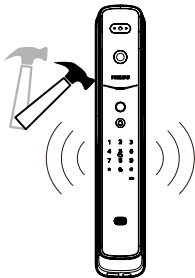

Triggering 1: The door is pried open, and the sensor latch bolt pops up.

Alert mode: Continuously repeated alert.

Off: The alert will be off automatically or off after a successful access verification.

Triggering 2: Outside escutcheon is pried open, and there is no fit to the door.

Alert mode: Continuously repeated alert.

Off: Auto-close, or close after a successful access verification, or close after unlocking from inside.

Deadbolt abnormality alert

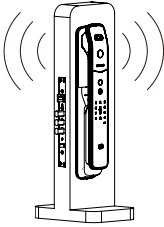

Triggering: If the deadbolt works abnormally, the door fails to lock or unlock.

Alert mode: Continuously repeated alert.

Off: The alert will be automatically off.

Motion detection alert

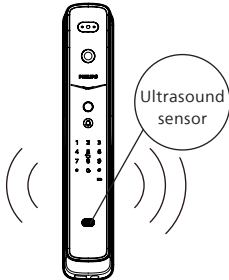

Triggering: When a suspicious person is loitering around at the front door for a period that exceeds the set value, the loitering alert will be triggered.

Alert mode: The camera will capture a video by default and send a notification to the APP.

Off: Motion detection is off by default, if you need to use this feature, you can enable or disable it on the APP.

⚠ Attention

1. The motion detection alert is off by default. To enable this feature, please log in to the APP, bind the door lock on home page. Once the binding process is done, go to "Settings" and turn on "loitering alert".
2. The more the video function used, the faster the power consumption will be. To reduce the detection frequency and battery consumption, it is suggested to set the motion detection sensitivity level to "Low".

How to apply an external power supply

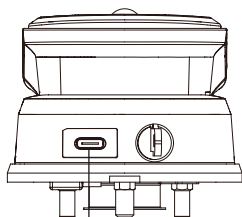

Reset & External power supply interface

When the battery voltage is insufficient, and the door cannot open from outside, you can power up the lock through a 5V power bank as an external power supply. After opening the door lock, please replace the batteries immediately. In case of a system crash and it's unable to open the door from outside, please use an external power supply to power up the door lock, then it can be rebooted automatically.

Battery replacement

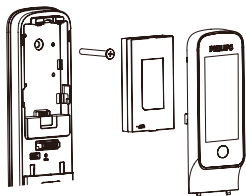

The working power of the door lock is a 5000mA/h Li-polymer battery. The battery compartment locates at the upper end of the inside escutcheon. You can slide the battery cover upwards and remove the cover to replace the battery.

Battery recharge

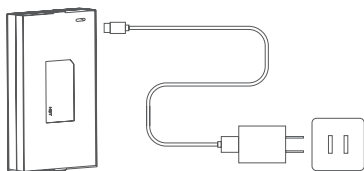

Remove the battery from the door lock and charge it via a charging cable.

⚠ Attention

1. The warranty period for the Li-polymer battery is 1 year.
2. The charging voltage is 5V.
3. When the network condition is unstable, it will accelerate the battery aging.



Philips and the Philips Shield Emblem are registered trademarks of Koninklijke Philips N.V. and are used under license. This product has been manufactured by and is sold under the responsibility of Shenzhen Conex Intelligent Technology Co., Ltd. and Shenzhen Conex Intelligent Technology Co., Ltd. is the warrantor concerning this product.