

PHILIPS

Home Access

Smart deadbolt

5000 series

User Manual

Register your product and get
support at www.philips.com/support



Contents

1 Warnings & Safety **02**

Safety
Caution
Returns & Disposal

2 How to Install **03**

Parts List
Assembly View
Install the Lock
Install the Door Position Sensor

3 How to Setup **13**

Download the Philips Home Access App
Create a User Account
Add the Device
Calibrate the Door Position Sensor
Connect to Your Home Wi-Fi Network

4 How to Use **14**

Feature Definitions
Factory Reset & Default Settings
Format of Entry Methods
Add a Palm ID
Unlock with Palm ID
Lock & Unlock

5 Add the Chime **22**

Product Overview
Operations & Features
Add the Chime

6 Troubleshooting **25**

7 Warranty **27**

8 FCC Statement **28**

9 ISED Statement **29**

1 Warnings & Safety

Safety

- ◆ Before using this product, please read and understand all instructions. Damage caused by failure to follow the instructions is not covered by the warranty.
- ◆ Only use components the manufacturer provided and suggested accessories.
- ◆ Only use non-rechargeable CR123A Lithium Batteries.
- ◆ Do not forcibly disassemble the product to trigger an alarm or damage the product.
- ◆ Do not scrape the fingerprint sensor with sharp objects as this may cause permanent damage.
- ◆ Do not remove the batteries during lock setup and operation.
- ◆ Change the default master PIN code immediately via the Philips Home Access app after completing the installation.

Caution

- ◆ Do not place the batteries near fire sources.
- ◆ Do not connect the 2 poles of the batteries to metals to avoid a short circuit and potential explosion.
- ◆ Any replacement component should be performed by Philips, a Philips-authorized service center, or a professional technician.
- ◆ Do not use parts or accessories manufactured by others, except batteries.
- ◆ Do not expose products to places that have water leakage or splashing.

Returns & Disposal

- ◆ Locks can be returned at an authorized Philips service center. Appropriate compensation will be provided if the returned product meets Philips's conditions.
- ◆ Please follow local regulations and do not throw the used products or batteries into normal household waste.

2 How to Install

Parts List

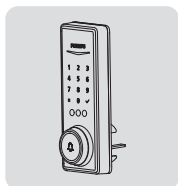

① Exterior Assembly

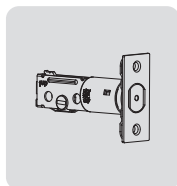

② Latch Bolt

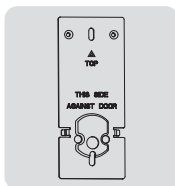

③ Mounting Plate

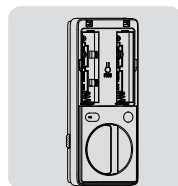

④ Interior Assembly

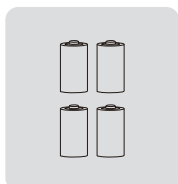

⑤ CR123A Lithium Batteries (4)

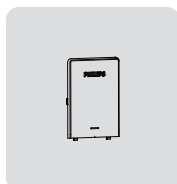

⑥ Battery Cover

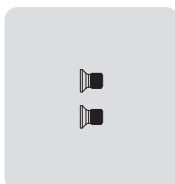

⑦ Interior Assembly Screws (2)

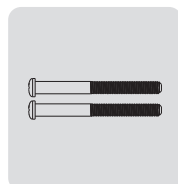

⑧ Mounting Plate Screws (2)

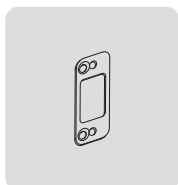

⑨ Reinforcement Plate (Optional)

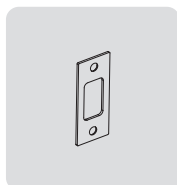

⑩ Strike Plate

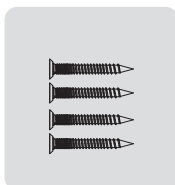

⑪ Strike Plate Screws (2)
Reinforcement Plate Screws (2)

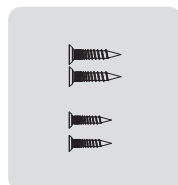

⑫ Latch Bolt Screws (2)
Door Sensor Screws (2)

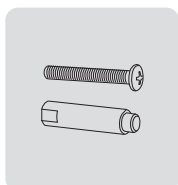

⑬ Upper Screw & Screw Post (Optional)

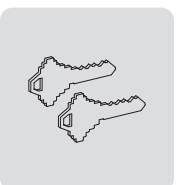

⑭ Backup Keys

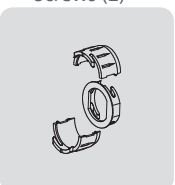

⑮ Drive-In Collar (Optional)

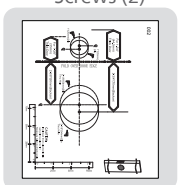

⑯ Drilling Template

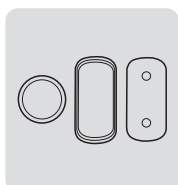

⑰ Door Position Sensor
Door Position Sensor Cap

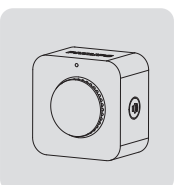

⑱ Wireless Chime

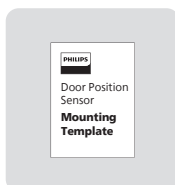

⑲ Door Position Sensor
Mounting Template

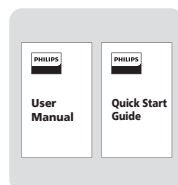

⑳ User Manual
Quick Start Guide

Assembly View

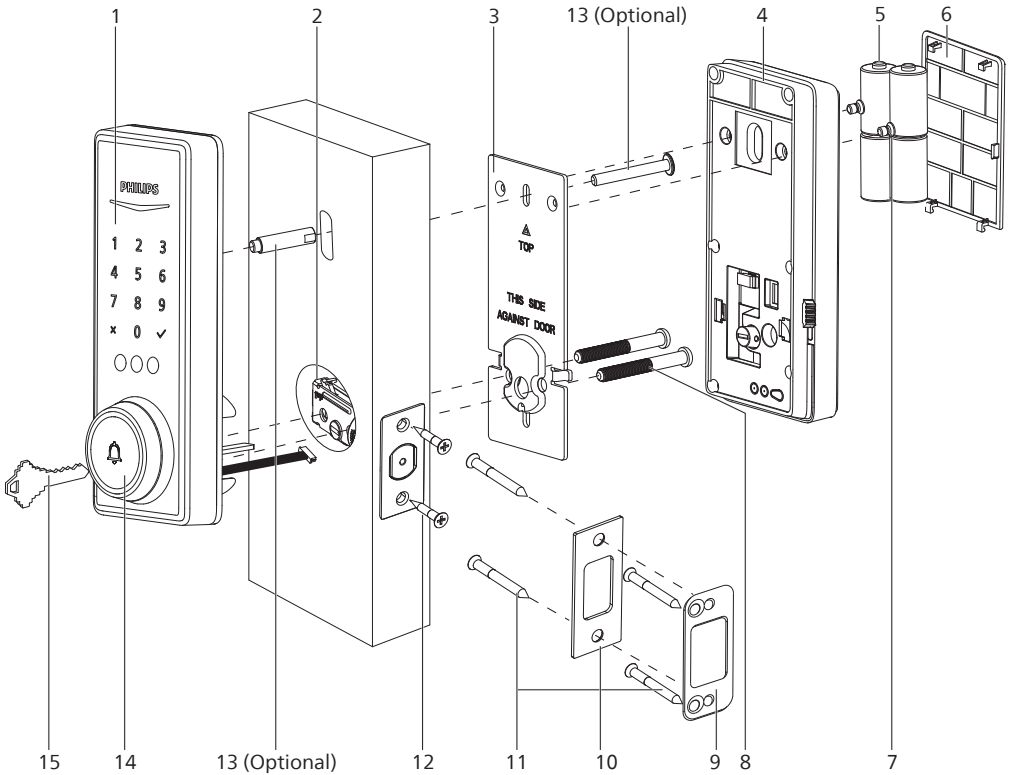

- | | |
|---------------------------------|---|
| 1. Exterior Assembly | 9. Reinforcement Plate (Optional) |
| 2. Latch Bolt | 10. Strike Plate |
| 3. Mounting Plate | 11. Strike Plate Screws (2) |
| 4. Interior Assembly | Reinforcement Plate Screws (Optional) (2) |
| 5. CR123A Lithium Batteries (4) | 12. Latch Bolt Screws (2) |
| 6. Battery Cover | 13. Upper Screw and Screw Post (Optional) |
| 7. Interior Assembly Screws (2) | 14. Keyhole Cover & Doorbell Button |
| 8. Mounting Plate Screws (2) | 15. Backup Keys (2) |

Exterior Assembly

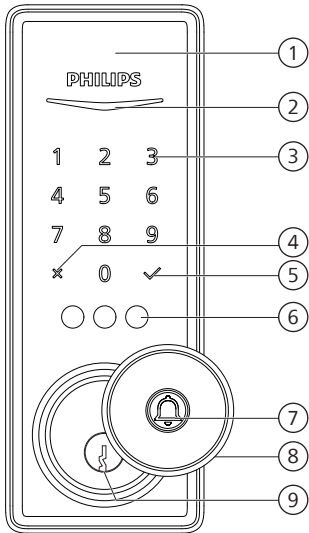

1	Exterior Proximity Sensor
2	Status Indicator
3	Touchscreen Keypad
4	Cancel Key
5	Confirm Key
6	Palm ID Reader
7	Doorbell
8	Keyhole Cover
9	Keyhole

Interior Assembly

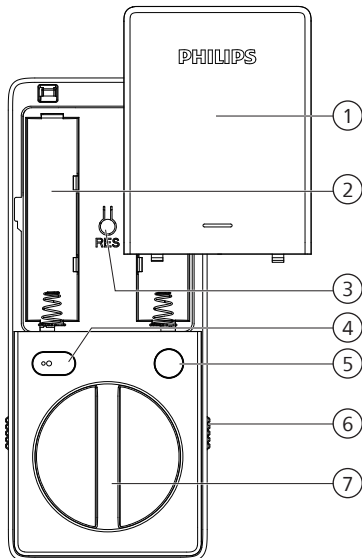

1	Battery Cover
2	CR123A Lithium Batteries
3	Reset Button
4	Interior Proximity Sensor
5	Privacy Button
6	Installation Buckle
7	Thumb Turn

Install the Lock

Required Tools



#2 Phillips Screwdriver

Prepare the Door and Check the Dimensions

- ① Measure to confirm that the hole in the door is 1-1/2" or 2-1/8" (38mm or 54mm).
Measure to confirm that the hole in the door edge is 1" (25mm).
- ② Measure to confirm that the backset is either 2-3/8" or 2-3/4" (60mm or 70mm).

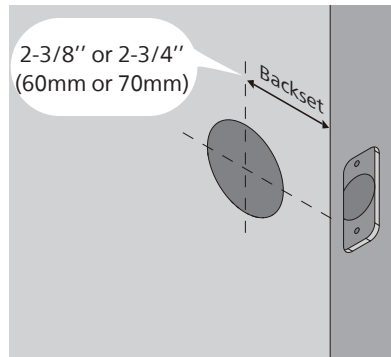
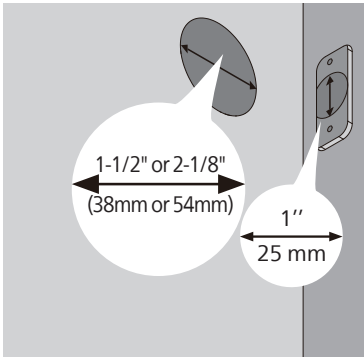

- ③ Measure to confirm that the door is 1-3/8" to 2" (35mm to 50mm) thick.
- ④ Make sure the hole in the door frame is drilled a minimum of 1" (25mm) deep to leave enough space for the deadbolt to extend into the door frame when the door is locked.

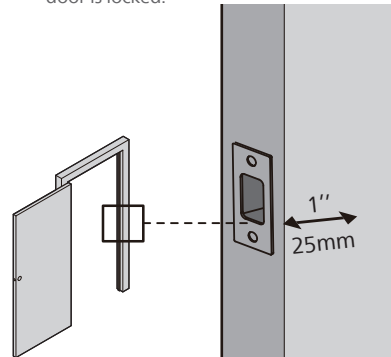
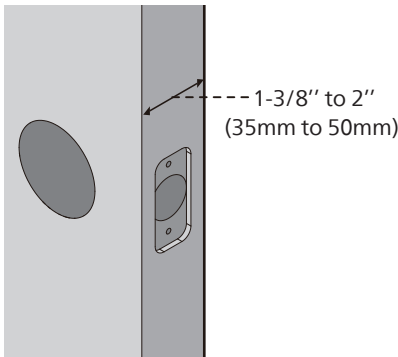

⚠ Attention

Make sure the door frame is aligned with the door and there are no obstructions in the door frame.

5 OPTIONAL: Drill a hole for Upper Screw.

⚠ Attention

Installing this screw onto the Exterior Assembly is OPTIONAL. It is used for additional security or when a door is weak or warped.

If you install this screw, you need to drill a hole (19/32") in the door before starting the installation.

Drilling Template

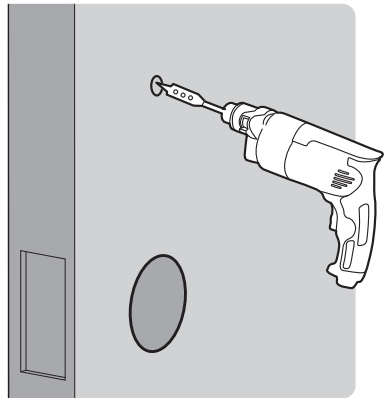
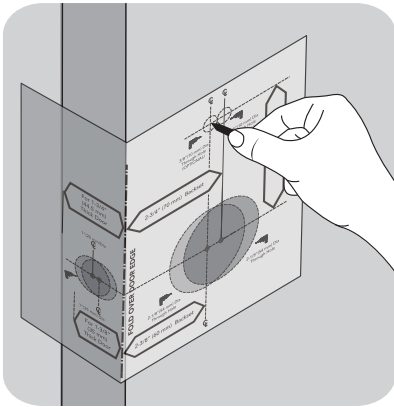

⑥ Determine the backset and adjust the Latch Bolt.

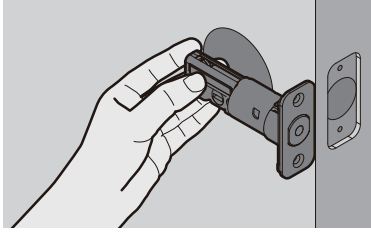

Hold the Latch Bolt in front of the door hole, with the Latch Bolt face flush against the door edge. Is the slotted hole centered in the door hole?

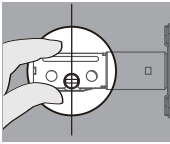

YES

No adjustment is required.
Proceed to the next step.

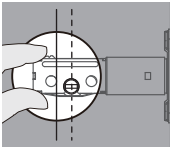

NO

The slotted hole is NOT centered.
Rotate and pull the Latch Bolt as shown to extend it.

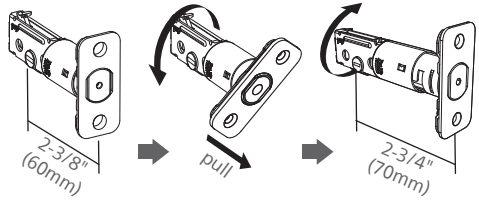

⑦ Install the Latch Bolt.

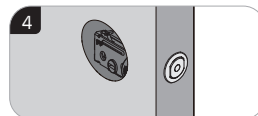
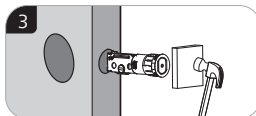
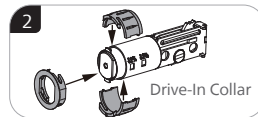
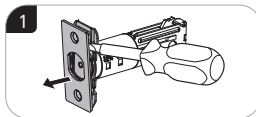
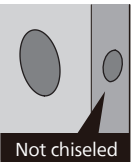
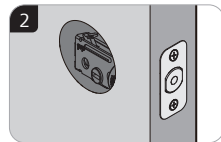
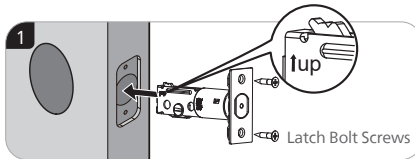
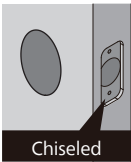

- 8 Use a screwdriver to confirm that the deadbolt locks and unlocks smoothly.

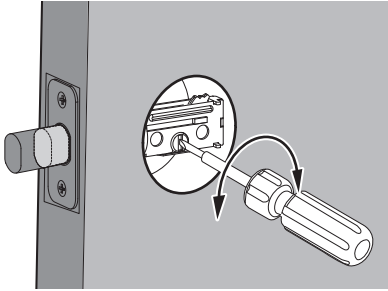

- 9 Install the Strike Plate on the door frame.

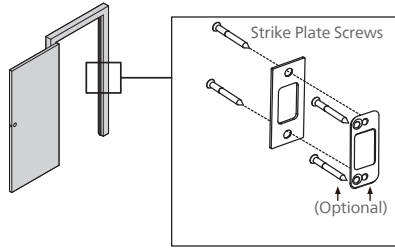

Attention

Make sure the hole in door frame is drilled a minimum of 1"(25mm) deep.

Install the Exterior Assembly

Attention

Before installing the Exterior and Interior Assembly, make sure the Latch Bolt is fully retracted (in the unlocked position).



Do not insert the key when you are installing.

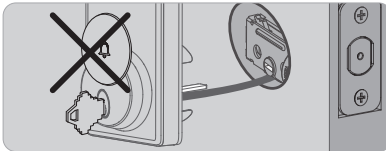

Measure the diameter of the hole in the door.

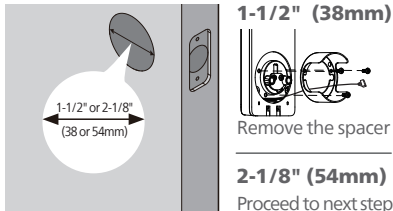

- 10 With the Latch Bolt fully retracted (in the unlocked position), route the cable below the Latch Bolt, and insert the tailpiece through the slot in the Latch Bolt.

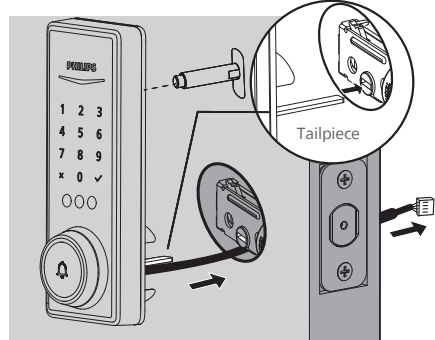

Attention

The Upper Screw & Screw Post on the top is OPTIONAL. It is used for additional security, or when a door is weak or warped.

- 11 Move the Installation Buckles on both sides of the Interior Assembly upwards to remove the Mounting Plate from the interior base.

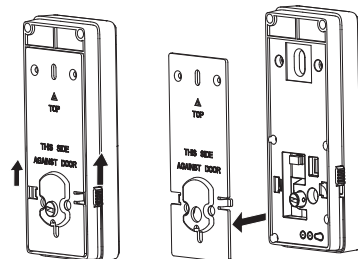

- 12 Secure the Mounting Plate with the Mounting Plate Screws. Do not overtighten screws.

⚠ Attention

Route the cable through the hole in the Mounting Plate.

The Upper Screw on the top is OPTIONAL.

Before installing the Upper Screw, fasten the Screw Post into the hole of the Exterior Assembly.

Keep parallel to door edge.

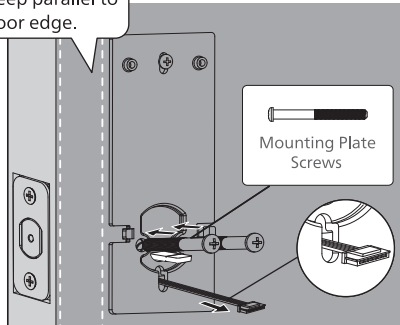

Install the Interior Assembly

- 13 Push the Battery Cover up in the direction as illustrated.

⚠ Attention

Do not load batteries before finishing the lock installation.

- 14 Insert the cable connector of the Exterior Assembly to the socket on the Interior Assembly. Push the connector in firmly until it is completely attached.

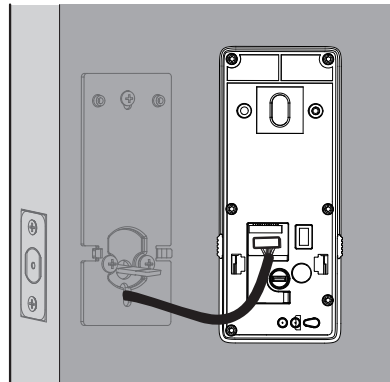
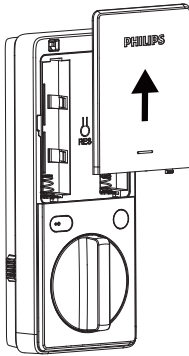

- 15 Keep the Thumb Turn in the vertical position, toggle the Installation Buckle upwards, and install the Interior Assembly.

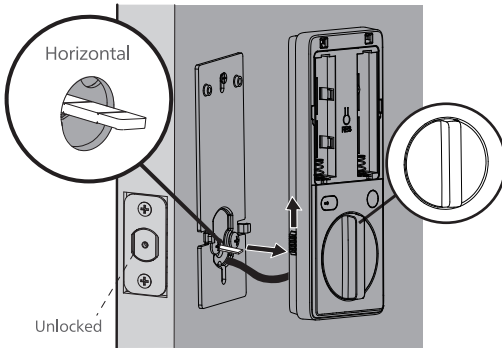

- 16 Attach the Interior Assembly to the Mounting Plate, toggle the Installation Buckle downwards, and fasten using the Interior Assembly Screws.

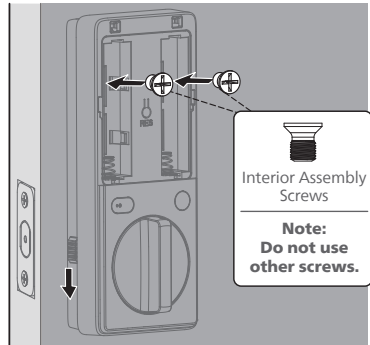

⚠ Attention

Ensure the cable is not pinched or the lock will not function properly.

- 17 Install the 4 CR123A batteries.

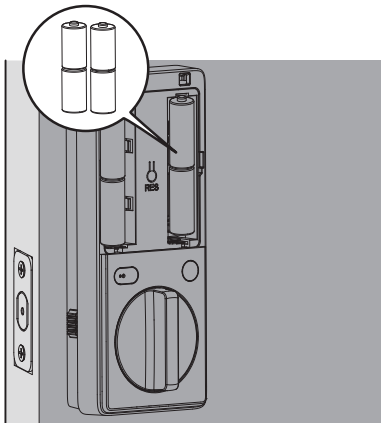

- 18 Press and hold the Reset Button for at least 5 seconds until you hear a beep. This activates the lock-handing process and must be completed before setting up the lock.

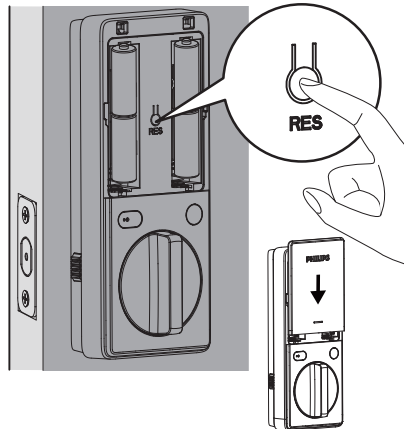

Need help?



U.S.A. & Canada: +1(833)599-9111

Install the Door Position Sensor

Assembly View

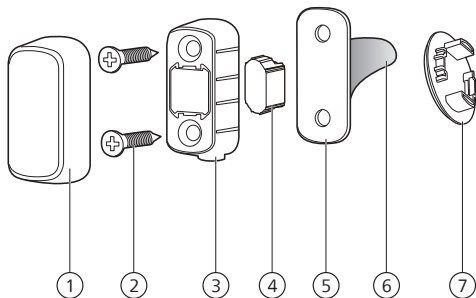

1	Cover
2	Door Position Sensor Mounting Screws (Optional) (2)
3	Mounting Housing
4	Magnet
5	Door Position Sensor Mounting Template
6	Mounting Tape
7	Door Position Sensor Cap (Optional)

How to Install

There are two ways to install the Door Position Sensor: **Surface Mount** and **Flush Mount**. Refer to the Door Position Sensor Mounting Template in the box for specific operations.

It is recommended to install the Door Position Sensor using the Surface Mount method to avoid drilling additional holes in your door.

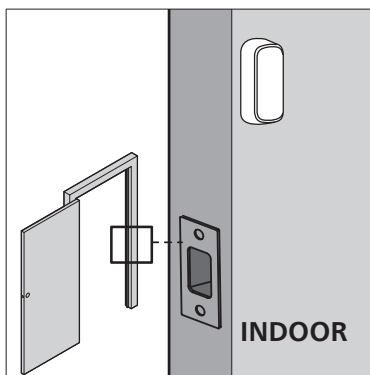

Surface Mount



Flush Mount

⚠ Attention

If you want to use the Door Position Sensor but prefer not to drill into the door frame, install the surface mounted Door Position Sensor using the Mounting Tape ONLY.

3 How to Setup

Download the Philips Home Access App

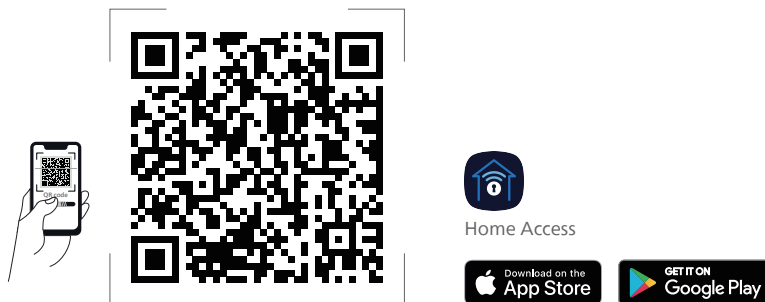

Scan the QR Code to download the Philips Home Access app.

Create a User Account

Register and log in to the Philips Home Access app.

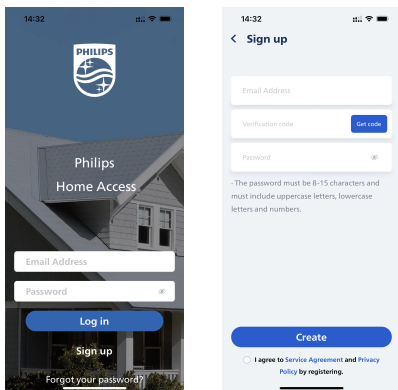

Add the Device

Enable Bluetooth on your phone and click the "Add device" button on the app.

Scan the QR Code or manually enter the ESN located on the back of the Battery Cover and complete the pairing steps following the in-app instruction.

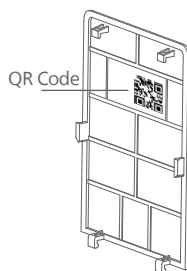

Calibrate the Door Position Sensor

Follow the instructions in the app until you have successfully calibrated your smart lock and the Door Position Sensor together.

Attention

The process of calibrating the Door Position Sensor should be carried out near the smart lock.

If the Philips Home Access app fails to calibrate the lock, check whether the Door Position Sensor has been installed correctly and try again.

Connect to Your Home Wi-Fi Network

Follow the instructions to connect the lock to the Wi-Fi network.

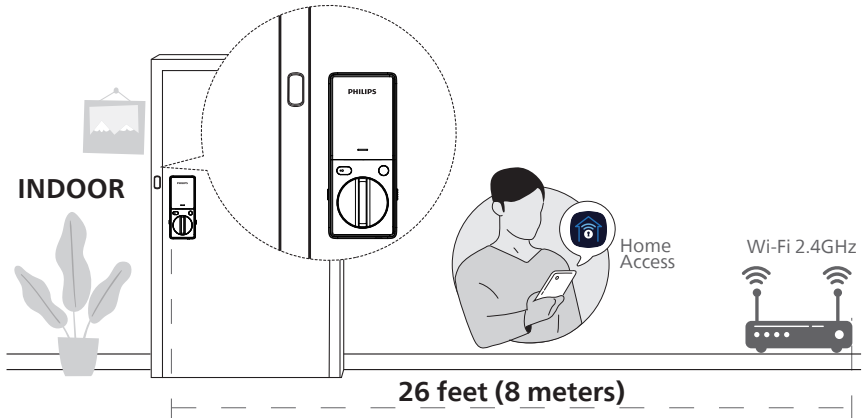

⚠ Attention

The lock is only compatible with the 2.4 GHz Wi-Fi network. Make sure your phone is connected to the same 2.4 GHz Wi-Fi before operating.

For optimum connectivity, it is recommended that the home router be no further away from the lock than 26 feet (8 meters).

During the connect process position yourself between the lock and the Wi-Fi Router.

4 How to Use

Feature Definitions

Master PIN code

The Master PIN Code can be used to unlock the deadbolt in Away Mode and Privacy Mode. The default Master PIN Code (12345678) must be changed before setting up. The owner/manager should keep this information confidential.

Multiple Ways to Unlock

Unlock with your Plam(s), PIN Codes, Backup Keys, or a gentle touch on the Philips Home Access app. The Palm IDs and PIN Codes can be managed on the Phillips Home Access app.

Simple Sharing

Tap "Share device" on the Phillips Home Access app to share access with your family or friends. The access can only be shared and accepted via the Phillips Home Access app.

Lock Activity

Offers a detailed record of all lock interactions and activities like lock/unlock history and user access. Real-time notifications will be sent to your phone when your smart lock is connected to the home Wi-Fi network.

Temporary PIN Codes

Generate PIN codes remotely for guests or a service technician through the Philips Home Access app. It can be a One-Time PIN Code that will be deleted upon use or a duration PIN code that will work repeatedly during a specific period of time.

One-Touch Locking

Lock the door by simply pressing and holding any key on the touchscreen for 2s.

Auto-Lock

The unit will automatically lock after it has been unlocked when this setting is on. This feature is disabled by default. The time delay can be programmed between 30 and 180 seconds in the Philips Home Access app. The auto lock can also be set in the Philips Home Access app after calibrating the door position sensor for an immediate auto-lock when the door is closed.

Wrong Entry Limit

After 10 unsuccessful attempts to unlock by PIN Code and/or Palm ID, the keypad will be temporarily disabled for 3 minutes.

Silent Mode

The sounds can be muted when pressing the keypad. However, you will still hear low battery warnings and system alerts.

Away Mode

This is a safety feature when you leave your house for a vacation or long trip. Away Mode restricts all User PIN Codes and Palm ID until the Master PIN Code is entered on the touchscreen keypad. When the lock is unlocked by the Thumb Turn, an alarm will sound for 1 minute. It will also send a notification via the Philips Home Access app.

Enable it by setting it on the Philips Home Access app.

By entering the Master PIN Code on the keypad or setting it on the Philips Home Access app, you can disable the alarm and the Away Mode.

Privacy Mode

Push and hold the Privacy Button on the Interior Assembly for 3 seconds to activate Privacy Mode. This will restrict all User PIN Codes and Palm IDs. Privacy Mode will be disabled automatically after unlocking the door with the Thumb Turn or the Master PIN Code.

Grab and Go

The deadbolt will automatically unlock as you approach and grab the door knob or lever indoors. This feature is disabled by default.

Enable it by setting it on the Philips Home Access app.

Low Battery Alarm

When the batteries are running low, the battery indicator will flash and a voice will announce "Low battery. Please replace batteries as soon as possible". It will also send a notification via the Philips Home Access app.

Replace the low batteries with 4 new CR123A Lithium Batteries.

Factory Reset & Default Settings

This procedure erases all user and network settings and unpairs the lock from users' accounts.

All paired accessories will also be removed. Restoring the lock will also activate the lock-handing process.

Press the Reset Button for at least 5 seconds until you hear the tone prompting you to restore the default settings.

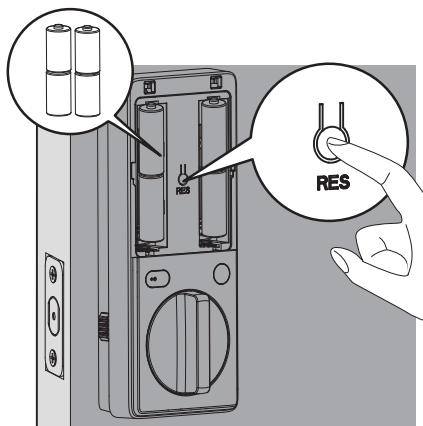

Function	Default Setting
Master PIN Code	12345678
Auto-Lock	Disabled
Silent Mode	Disabled
Shut Down Time	3 minutes
Away Mode	Disabled

Format of Entry Methods

- Master PIN Code (4 to 10 digits): The default Master PIN Code is 12345678. Change the default Master PIN Code before setting other codes.
- User PIN Code (4 to 10 digits): A total of 100 User PIN Codes can be set and stored in the lock.
- Palm ID: 50 Palm IDs can be set and stored in the lock.
- Both Master and User PIN Codes do not support the following combination of numbers:

- | | | | | | | | | | |
|--------------------------|---|---|---|---|---|---|---|---|---|
| A. Forward number | A. <table border="1" style="display: inline-table;"><tr><td>1</td><td>2</td><td>3</td><td>4</td><td>5</td><td>6</td><td>7</td><td>8</td></tr></table> ✗ | 1 | 2 | 3 | 4 | 5 | 6 | 7 | 8 |
| 1 | 2 | 3 | 4 | 5 | 6 | 7 | 8 | | |
| B. Backward number | B. <table border="1" style="display: inline-table;"><tr><td>8</td><td>7</td><td>6</td><td>5</td><td>4</td><td>3</td><td>2</td><td>1</td></tr></table> ✗ | 8 | 7 | 6 | 5 | 4 | 3 | 2 | 1 |
| 8 | 7 | 6 | 5 | 4 | 3 | 2 | 1 | | |
| C. Repeated number | C. <table border="1" style="display: inline-table;"><tr><td>2</td><td>2</td><td>2</td><td>2</td><td>2</td><td>2</td><td>2</td><td>2</td></tr></table> ✗ | 2 | 2 | 2 | 2 | 2 | 2 | 2 | 2 |
| 2 | 2 | 2 | 2 | 2 | 2 | 2 | 2 | | |
| D. Contain existing code | D. If <table border="1" style="display: inline-table;"><tr><td>5</td><td>6</td><td>8</td><td>3</td></tr></table> ✓ | 5 | 6 | 8 | 3 | | | | |
| 5 | 6 | 8 | 3 | | | | | | |
| | then <table border="1" style="display: inline-table;"><tr><td>5</td><td>6</td><td>8</td><td>3</td><td>9</td><td>1</td></tr></table> ✗ | 5 | 6 | 8 | 3 | 9 | 1 | | |
| 5 | 6 | 8 | 3 | 9 | 1 | | | | |
| | and <table border="1" style="display: inline-table;"><tr><td>9</td><td>1</td><td>5</td><td>6</td><td>8</td><td>3</td></tr></table> ✗ | 9 | 1 | 5 | 6 | 8 | 3 | | |
| 9 | 1 | 5 | 6 | 8 | 3 | | | | |

Add a Palm ID

1. Click the "Add Palm ID" button in the Philips Home Access app.
2. Follow the in-app instructions and place your palm in front of the Palm ID Reader. Keep your palm still while the Palm ID Reader is scanning your palm. The Palm ID Reader will scan your palm vein patterns to create your unique Palm ID. All of the Palm IDs are securely stored locally.
3. Name the new Palm ID in the app.

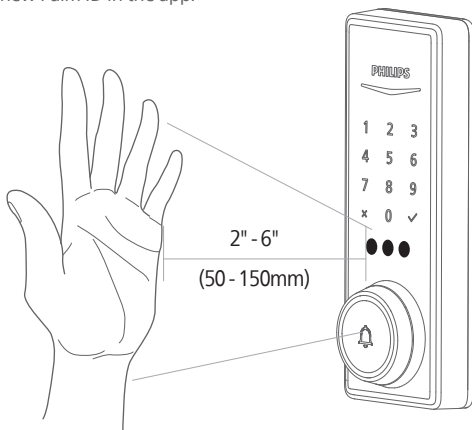

Attention

- Ensure your palm is about 2"-6" (50-150mm) from the Palm ID Reader.
- Ensure that nothing covers the Palm ID Reader or your palm.
- Hold your hand still during the Palm ID enrollment process.

After adding a Palm ID, the Palm ID reader can recognize any palm direction within a 180-degree range centered on the palm.

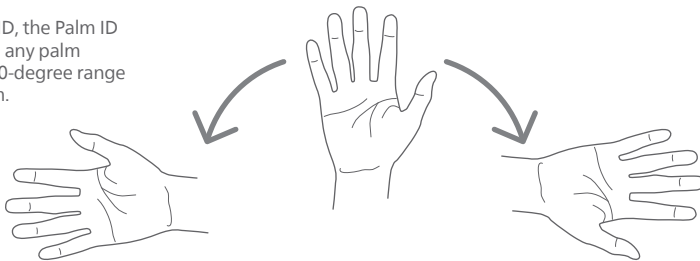

It is recommended to add two Palm IDs for each palm. Place your palm upward to add the first Palm ID, and place the same palm downward to add the second Palm ID. This way, you will be able to unlock the lock regardless of the position of your palm.

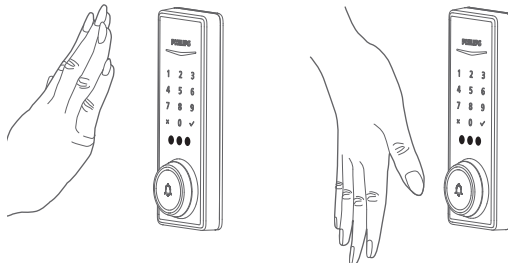

Unlock with Palm ID

The Palm ID reader will automatically wake up once you approach the lock. Place your palm in front of the Reader to verify your Palm ID and unlock the door.



Attention

Ensure your palm is about 2"-6" (50-150mm) from the Palm ID Reader.

While verifying your Palm ID, keep your palm in front of the Palm ID Reader area until both the Palm ID Reader and Touchscreen Keypad lights go out.

Ensure to hold your hand still when unlocking with Palm ID.

Lock & Unlock

Unlocking the Door from Outside

1. Unlock by PIN Codes.
2. Unlock with Palm ID.
3. Unlock by Backup Key.
4. Unlock by the Philips Home Access app.

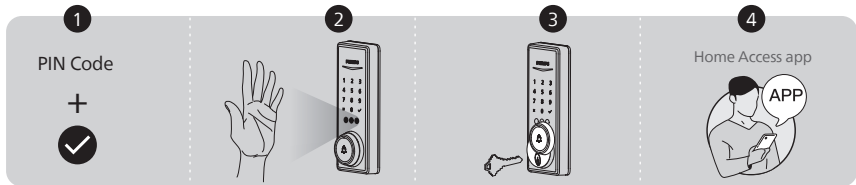

Unlocking the Door from Inside

1. Rotate the Thumb Turn to the unlocked position.
2. Unlock by the Philips Home Access app.
3. Unlock by Voice Assistant.
4. Grab and go. (Disabled by default)

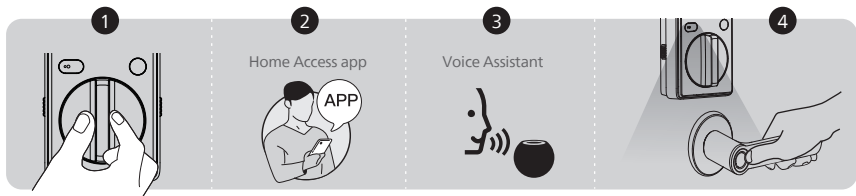

Locking the Door from Outside

1. Press and hold any key on the touchscreen keypad for at least 2 seconds to lock the device in Manual Mode.
2. In Auto-Lock mode, the Latch Bolt will automatically extend after it is unlocked and the door is shut.
3. Lock by the Philips Home Access app.
4. Lock by the Backup Key.

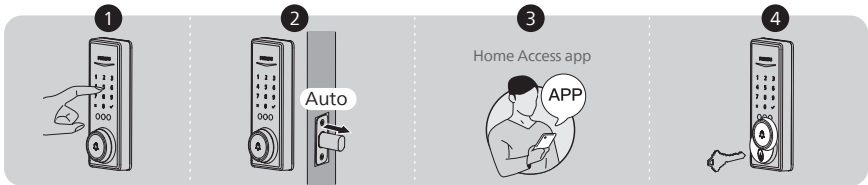

Locking the Door from Inside

1. Rotate the Thumb Turn to the locked position to lock the device in Manual Mode.
2. Press the Privacy Button to lock the device in Manual Mode.
3. In Auto-Lock Mode, the device is locked automatically.
4. Lock by the Philips Home Access app.
5. Lock by Voice Assistant.

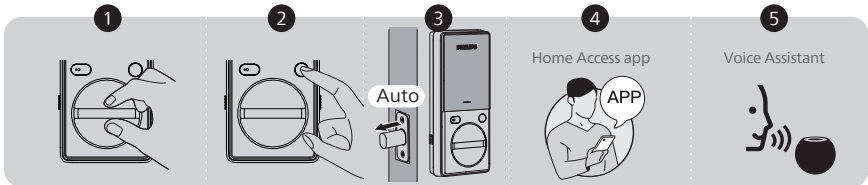

5 Add the Chime

Product Overview

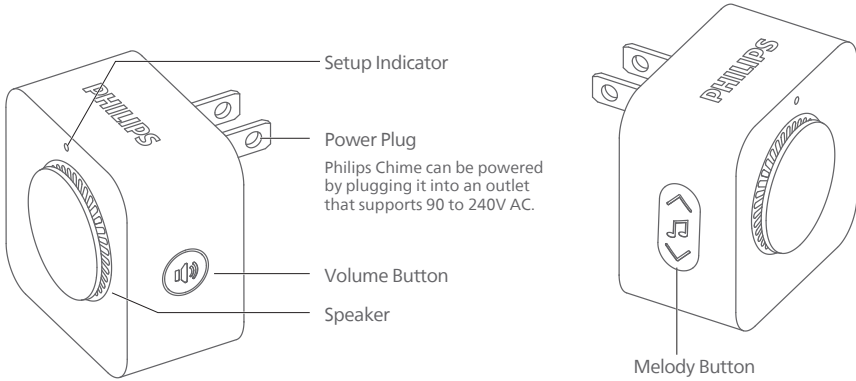

Operations & Features

Single-click the Volume Button	Change the volume level	5 levels of volume adjustable: 40dB, 50dB, 60dB, 65dB, 75dB loud.
Press & hold the Volume Button	Press and hold for 5 seconds to enter Pairing Mode	The Indicator will flash while in Pairing mode. The Indicator will be illuminated while in Pairing mode.
Melody Button	Click the arrows to scroll up or down to select the melody you like	Contains 38 melodies, and automatically saves the set melody after powering off.

Add the Chime

1. Plug the Chime into any standard power outlet.
(Suggestion: Plug the Chime into the outlet near the lock, and transfer it to another room after adding it).

After the Chime is successfully paired, it can be moved to other rooms.

The maximum distance between the Chime and the smart lock is 328 feet (100m) in an open space.

It is recommended that there be no more than three walls between the Chime and the lock.

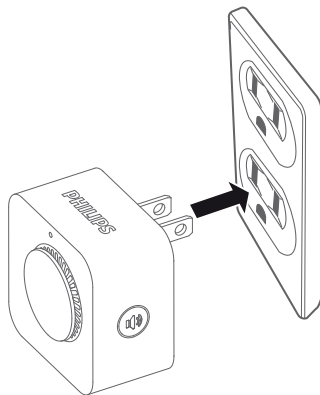

2. Open the Philips Home Access app and select the lock you want to add the Chime to and find the "Add accessories" option.

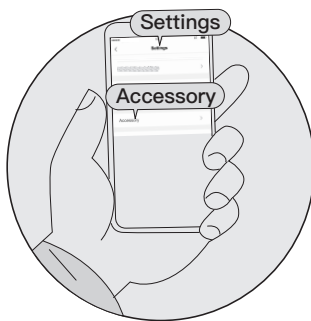

3. Press and hold the Chime's Setup Button for 3 seconds to enter Pairing Mode.

You will see the Chime's Indicator Light flash 1 time, and then the light will remain on. At the same time, you can hear a "Ding Dong" sound, indicating it is ready to pair with the lock.

Pairing the Chime will last for 1 minute.

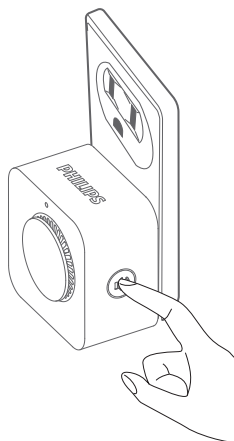

4. Follow the in-app instructions to complete the pairing.

When the Chime's Indicator Light flashes 1 time and rings again, that means they have connected and are able to function together.

5. After adding the Chime, try the doorbell on the lock and check whether the Chime works appropriately.

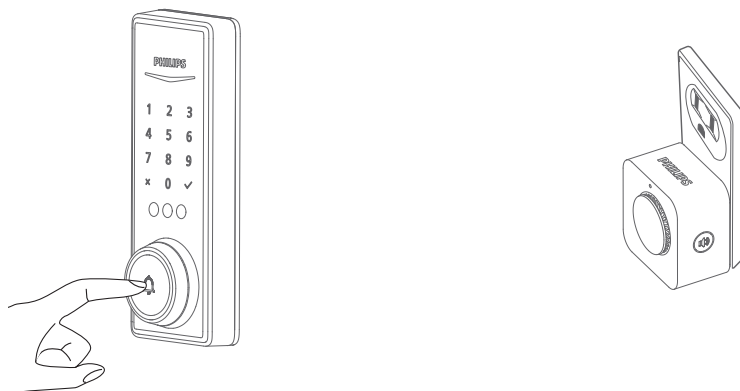

⚠ Attention

A Philips smart deadbolt can be connected to multiple Chimes, and a Chime can be added with multiple Philips smart deadbolts.



6 Troubleshooting

Issue	Solution
The Latch Bolt does not operate correctly after installation.	<ul style="list-style-type: none">◆ Make sure the backset on the Latch Bolt is set to the proper length. Refer to page 8.◆ Make sure the latch bolt is retracted before installation. Refer to page 9.◆ Restore the lock to the default settings. Enter the default Master PIN Code to set up the lock.
The lock does not smoothly lock or unlock while using the Thumb Turn.	<ul style="list-style-type: none">◆ Confirm the Mounting Screws are properly installed.
Failed to set up the lock in the app.	<ul style="list-style-type: none">◆ Make sure the lock is installed correctly.◆ Insert fresh batteries and make sure that the cable is not pinched.◆ After installation, reset the lock to factory settings to complete the lock setting process.
Failed to connect to Wi-Fi.	<ul style="list-style-type: none">◆ An unstable Wi-Fi signal affects the connection between the device and your Wi-Fi router. It would be best if you strengthen the Wi-Fi signal to the device to ensure it operates properly.◆ Check your available networks. Make sure your lock is connected to a 2.4GHz Wi-Fi network or "dual-band" Wi-Fi, which supports both 2.4GHz and 5GHz frequency bands.◆ Check to make sure you have entered the correct Wi-Fi password.◆ Ensure your Wi-Fi password is less than 26 characters and does not contain Spaces.◆ Try performing the setup on a different mobile device.◆ Perform a factory reset to repeat the setup process.
Failed to add the device via Bluetooth.	<ul style="list-style-type: none">◆ Make sure your smart lock has enough power, and your phone is close to it.◆ Check your phone's Bluetooth settings and ensure it's turned on.◆ If you have an Android device, enable the Location Service.
Failed to Scan the QR Code on the device.	<ul style="list-style-type: none">◆ Scan the QR Code in a well-lit environment, use the built-in flashlight on your phone, or try to scan in an environment with sufficient lighting.◆ Ensure enough distance between your smartphone and the QR Code, and ensure the QR Code is at the center of your phone screen.◆ Direct lighting or sunlight can cause reflections that will interfere with the scanning process.

Issue	Solution
I cannot unlock the device with my palm ID.	<ul style="list-style-type: none"> ◆ Ensure that nothing is covering the Palm ID Reader and your palm is not obscured. ◆ Ensure that the palm being used has been added successfully. ◆ Ensure your palm is about 2"-6" (50-150mm) from the Palm ID Reader. Hold your hand still when unlocking with Palm ID. ◆ Delete and re-add this Palm ID to the Philips Home Access app. Make sure the palm is not obscured and centered in front of the Palm ID reader when adding it. When adding your Palm ID, hold your hand still during the Palm ID enrollment process. If you only add a Palm ID in an upward direction of your palm, flipping the palm may cause an unlocking failure. Make sure your palm is facing the same direction as when you added it - see page 18. ◆ After adding a Palm ID, the Palm ID reader can recognize any direction your palm is turned within a 180-degree range centered on the palm. It is recommended to add two Palm IDs for each palm. Place your palm upward to add the first Palm ID, and place the same palm downward to add the second Palm ID. This way, you will be able to unlock the lock regardless of the position of your palm. See page 18 for more details. ◆ Ensure your lock has enough power. If the batteries are running low, unlock the device with a key, remove the batteries, and insert 4 new CR123A Lithium Batteries.
The device is showing offline.	<ul style="list-style-type: none"> ◆ Ensure your lock has enough power. If the batteries run low, please remove the batteries and insert 4 new CR123A Lithium Batteries. ◆ Please verify if your router has Internet access. If the home network experiences an outage or a network connectivity issue, the lock is expected to restore its Wi-Fi connection when the home network recovers. ◆ If the home network is back online and the lock has not restored its Wi-Fi connection, you may try resetting your lock.
The app displays that the door is open when the door is closed.	<ul style="list-style-type: none"> ◆ Metal objects and magnetic field changes near the door lock can affect the accuracy of the Door Sensor. To fix this, remove any potential sources of interference and recalibrate the Door Sensor within the app.
The lock rotates only if the Key is Inserted.	<ul style="list-style-type: none"> ◆ Make sure the Latch Bolt is installed correctly. Refer to page 9.
The door handing is not activated after the battery is installed.	<ul style="list-style-type: none"> ◆ Press the Reset Button for at least 5 seconds until you hear the tone prompting you to restore the default settings.
Receiving low battery alert.	<ul style="list-style-type: none"> ◆ Remove the batteries and insert 4 new CR123A Lithium Batteries.

Issue	Solution
The keypad is not responding.	<ul style="list-style-type: none"> ◆ Make sure batteries are inserted correctly. ◆ If the battery indicator flashes continuously, the batteries are low. Please replace them with 4 new CR123A Lithium Batteries. ◆ Make sure that the cable is properly connected and has not been damaged during installation.
The Master PIN Code cannot be changed.	<ul style="list-style-type: none"> ◆ Restore factory settings and reprogram all user PIN codes.
I forgot my Master PIN Code.	<ul style="list-style-type: none"> ◆ Perform a factory reset to clear all PIN Codes and Palm IDs. Once the reset is completed, all PIN codes will be deleted and the Master PIN Code will be reset to the default Master PIN Code of 12345678.
Auto-Lock is not working.	<ul style="list-style-type: none"> ◆ If the battery indicator flashes continuously, the batteries are low. ◆ Please replace them with 4 new CR123A Lithium Batteries. ◆ Activate the Auto-Lock function.

Still have questions or need help? Please feel free to contact us:



U.S.A. & Canada: +1(833)599-9111

7 Warranty

2 Years Warranty

For more information on the warranty applicable for this product, please visit www.philips.com or contact the dealer where you purchased the product.

8 FCC Statement

This equipment has been tested and found to comply with the limits for a Class B digital device, pursuant to part 15 of the FCC Rules. These limits are designed to provide reasonable protection against harmful interference in a residential installation. This equipment generates, uses and can radiate radio frequency energy and, if not installed and used in accordance with the instructions, may cause harmful interference to radio communications. However, there is no guarantee that interference will not occur in a particular installation. If this equipment does cause harmful interference to radio or television reception, which can be determined by turning the equipment off and on, the user is encouraged to try to correct the interference by one or more of the following measures:

- Reorient or relocate the receiving antenna.
- Increase the separation between the equipment and receiver.
- Connect the equipment into an outlet on a circuit different from that to which the receiver is connected.
- Consult the dealer or an experienced radio/TV technician for help.

Caution: Any changes or modifications to this device not explicitly approved by manufacturer could void your authority to operate this equipment.

This device complies with part 15 of the FCC Rules. Operation is subject to the following two conditions: (1) This device may not cause harmful interference, and (2) this device must accept any interference received, including interference that may cause undesired operation.

RF Exposure Information

This equipment complies with FCC radiation exposure limits set forth for an uncontrolled environment. This equipment should be installed and operated with minimum distance 20cm between the radiator and your body.

9 ISED Statement

English: This device contains licence-exempt transmitter(s)/receiver(s) that comply with Innovation, Science and Economic Development Canada's licence-exempt RSS(s). Operation is subject to the following two conditions:

- (1) This device may not cause interference.
- (2) This device must accept any interference, including interference that may cause undesired operation of the device.

The digital apparatus complies with Canadian CAN ICES-3 (B)/NMB-3(B).

French: Cet appareil contient des émetteurs/récepteurs exempts de licence qui sont conformes aux RSS exemptés de licence d'Innovation, Sciences et Développement économique Canada.

L'exploitation est soumise aux deux conditions suivantes :

- (1) Cet appareil ne doit pas provoquer d'interférences.
- (2) Cet appareil doit accepter toute interférence, y compris les interférences susceptibles de provoquer un fonctionnement indésirable de l'appareil.

L'appareil numérique du ciem conforme canadien peut-3 (b) / nmb-3 (b).

This device meets the exemption from the routine evaluation limits in section 2.5 of RSS 102 and compliance with RSS 102 RF exposure, users can obtain Canadian information on RF exposure and compliance.

cet appareil est conforme à l'exemption des limites d'évaluation courante dans la section 2.5 du cnr - 102 et conformité avec rss 102 de l'exposition aux rf, les utilisateurs peuvent obtenir des données canadiennes sur l'exposition aux champs rf et la conformité.

This equipment complies with Canada radiation exposure limits set forth for an uncontrolled environment.

Cet équipement est conforme aux limites d'exposition aux rayonnements du Canada établies pour un environnement non contrôlé.

This equipment should be installed and operated with minimum distance 20cm between the radiator & your body.

Cet équipement doit être installé et utilisé à une distance minimale de 20 cm entre le radiateur et votre corps.



Philips and the Philips Shield Emblem are registered trademarks of Koninklijke Philips N.V. and are used under license. This product has been manufactured by and is sold under the responsibility of Shenzhen Conex Intelligent Technology Co., Ltd. and Shenzhen Conex Intelligent Technology Co., Ltd. is the warrantor concerning this product.