

Register your product and get support at  
[www.philips.com/welcome](http://www.philips.com/welcome)

CE130



---

EN User manual

---

**PHILIPS**

# Contents

---

|                    |   |
|--------------------|---|
| <b>1 Important</b> | 4 |
| Safety             | 4 |
| Notice             | 4 |

---

|                                |   |
|--------------------------------|---|
| <b>2 Your car audio system</b> | 6 |
| Introduction                   | 6 |
| What's in the box              | 6 |
| Overview of the main unit      | 7 |

---

|                       |    |
|-----------------------|----|
| <b>3 Get started</b>  | 9  |
| Install the car audio | 9  |
| Turn on               | 12 |
| Set clock             | 12 |

---

|                                |    |
|--------------------------------|----|
| <b>4 Listen to radio</b>       | 13 |
| Tune to a radio station        | 13 |
| Store radio stations in memory | 13 |
| Tune to a preset station       | 13 |

---

|                           |    |
|---------------------------|----|
| <b>5 Play audio files</b> | 14 |
| Play from USB             | 14 |
| Insert a card             | 14 |
| Play options              | 14 |

---

|                                      |    |
|--------------------------------------|----|
| <b>6 Adjust sound</b>                | 16 |
| Adjust volume                        | 16 |
| Mute                                 | 16 |
| Turn on/off Max Sound                | 16 |
| Turn Dynamic Bass Boost (DBB) on/off | 16 |
| Select preset equalizer              | 16 |
| Switch music listening zone          | 16 |
| Other sound settings                 | 16 |

---

|                                 |    |
|---------------------------------|----|
| <b>7 Adjust system settings</b> | 17 |
| Turn beep sound on/off          | 17 |
| Select blackout setting         | 17 |
| Turn demo mode on/off           | 17 |
| Reset                           | 17 |

---

|                                 |    |
|---------------------------------|----|
| <b>8 Additional information</b> | 18 |
| Detach the front panel          | 18 |
| Replace fuse                    | 18 |
| Remove the unit                 | 18 |

---

|                              |    |
|------------------------------|----|
| <b>9 Product information</b> | 19 |
|------------------------------|----|

---

|                           |    |
|---------------------------|----|
| <b>10 Troubleshooting</b> | 20 |
|---------------------------|----|

---

|                    |    |
|--------------------|----|
| <b>11 Glossary</b> | 21 |
|--------------------|----|

# 1 Important

## Safety

- Read and understand all instructions before you use your apparatus. If damage is caused by failure to follow instructions, the warranty does not apply.
- This apparatus is designed for negative ground (earth) 12 V DC operation only.
- To ensure safe driving, adjust the volume to a safe and comfortable level.
- Improper fuses can cause damage or fire. When you need to change the fuse, consult a professional.
- Use only the supplied mounting hardware for a safe and secure installation.
- To avoid short circuit, do not expose the apparatus, remote control or remote control batteries to rain or water.
- Never insert objects into the ventilation slots or other openings on the apparatus.
- Clean the apparatus and frame with a soft, damp cloth. Never use substances such as alcohol, chemicals or household cleaners on the apparatus.
- Never place any objects other than discs into the apparatus.
- Never use solvents such as benzene, thinner, cleaners available commercially, or anti-static sprays intended for discs.
- Visible and invisible laser radiation when open. Avoid exposure to beam.
- Risk of damage to the apparatus screen! Never touch, push, rub or strike the screen with any object.

### ! Caution

- Use of controls or adjustments or performance of procedures other than herein may result in hazardous radiation exposure or other unsafe operation.
- The apparatus shall not be exposed to dripping or splashing.

- Do not place any sources of danger on the apparatus (e.g. liquid filled objects, lighted candles).

## Notice



The making of unauthorized copies of copy-protected material, including computer programs, files, broadcasts and sound recordings, may be an infringement of copyrights and constitute a criminal offence. This equipment should not be used for such purposes.



Windows Media and the Windows logo are trademarks, or registered trademarks of Microsoft Corporation in the United States and/or other countries.

This apparatus includes this label:

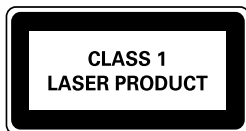

## Recycling



Your product is designed and manufactured with high quality materials and components, which can be recycled and reused. When you see the crossed-out wheel bin symbol attached to a product, it means the product is covered by the European Directive 2002/96/EC:



Never dispose of your product with other household waste. Please inform yourself about the local rules on the separate collection of electrical and electronic products. The correct disposal of your old product helps prevent potentially negative consequences on the environment and human health.

Your product contains batteries covered by the European Directive 2006/66/EC, which cannot be disposed of with normal household waste.

Please inform yourself about the local rules on separate collection of batteries. The correct disposal of batteries helps prevent potentially negative consequences on the environment and human health.



This product complies with the radio interference requirements of the European Community.

### **Environmental information**

All unnecessary packaging has been omitted. We have tried to make the packaging easy to separate into three materials: cardboard (box), polystyrene foam (buffer) and polyethylene (bags, protective foam sheet.)

Your system consists of materials which can be recycled and reused if disassembled by a specialized company. Please observe the local regulations regarding the disposal of packaging materials, exhausted batteries and old equipment.

Any changes or modifications made to this device that are not expressly approved by Philips Consumer Lifestyle may void the user's authority to operate the equipment.

2010 © Koninklijke Philips Electronics N.V. All rights reserved.

Specifications are subject to change without notice. Trademarks are the property of Koninklijke Philips Electronics N.V. or their respective owners. Philips reserves the right to change products at any time without being obliged to adjust earlier supplies accordingly.

## 2 Your car audio system

Congratulations on your purchase, and welcome to Philips! To fully benefit from the support that Philips offers, register your product at [www.philips.com/welcome](http://www.philips.com/welcome).

### Introduction

With the in-car audio system, you can enjoy your drive while listening to:

- FM or AM (MW) radio
- Audio from USB devices
- Audio from SD/SDHC card
- Audio from other external devices

The unit supports the following media format:



- ⑧ User manual
- ⑨ Quick start guide

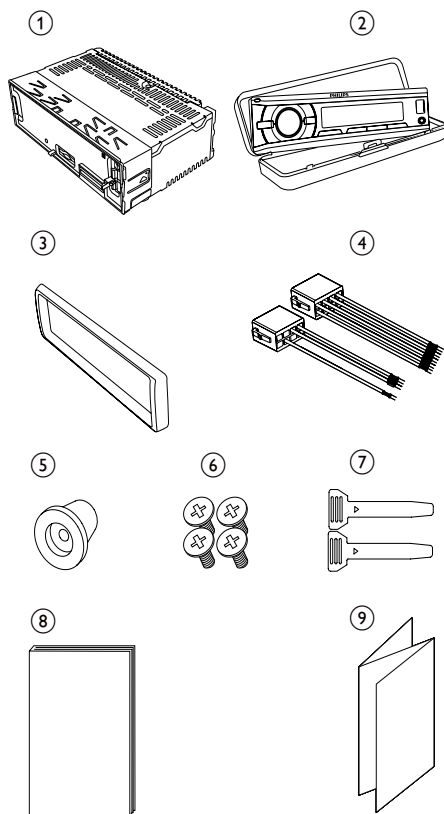

### What's in the box

Check and identify the contents of your package:

- ① Main unit (with a sleeve)
- ② Carrying case (includes the front panel)
- ③ Trim plate
- ④ ISO male connector
- ⑤ Rubber cushion
- ⑥ Screws x 4 pcs
- ⑦ Disassembly tools x 2 pcs

# Overview of the main unit

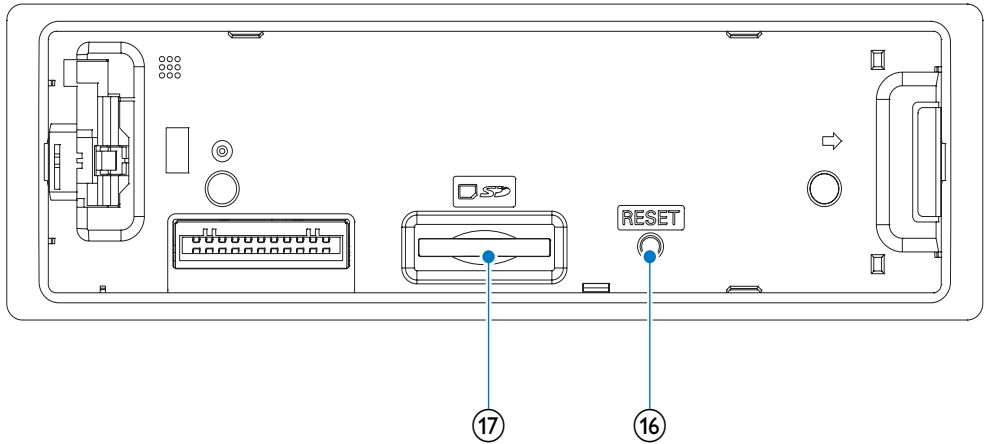
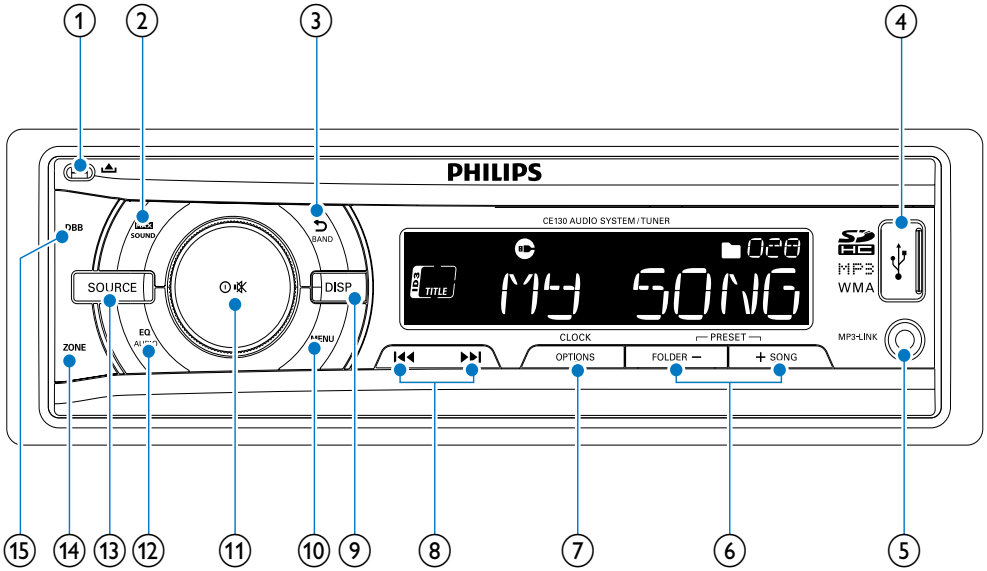

- ①
  - Unlock the panel.
- ②
  - Turn on or off Maximizing volume.
- ③ **BAND**
  - Select tuner band.
  - Return to previous menu.
- ④
  - USB socket.
- ⑤ **MP3 LINK**
  - Connect external audio device.
- ⑥ **+SONG/FOLDER -/PRESET**
  - Select preset radio station.
  - Search for track/folder.

- ⑦ **OPTIONS/CLOCK**
  - Access option menu.
  - View clock.
  
- ⑧ **⏮️/⏭️**
  - Tune for radio station.
  - Skip/search for track.
  - Fast forward/backward playback.
  
- ⑨ **DISP**
  - Display current status.
  
- ⑩ **MENU**
  - Access system menu.
  
- ⑪ **⏻/⏸️**
  - Turn the unit on or off.
  - Confirm selection.
  - Mute or unmute sound.
  - Rotate to adjust settings.
  
- ⑫ **EQ AUDIO**
  - Select equalizer (EQ) setting.
  - Access audio setting menu.
  
- ⑬ **SOURCE**
  - Select audio source.
  
- ⑭ **ZONE**
  - Switch the music listening zone.
  
- ⑮ **DBB**
  - Turn on/off Dynamic Bass Boost (DBB) sound.
  
- ⑯ **RESET**
  - Restore default settings.
  
- ⑰ **SD card slot**

# 3 Get started

## ! Caution

- Use the controls only as stated in this user manual.

Always follow the instructions in this chapter in sequence.

If you contact Philips, you will be asked for the model and serial number of your apparatus. The model number and serial number are on the bottom of your apparatus. Write the numbers here:

Model No. \_\_\_\_\_

Serial No. \_\_\_\_\_

## Install the car audio

These instructions are for a typical installation. However, if your car has different requirements, make the corresponding adjustment. If you have any questions regarding installation kits, consult your Philips car audio dealer.

## ! Caution

- This unit is designed for negative ground (earth) 12 V DC operation only.
- Always install this unit in the car dashboard. Other locations can be dangerous as the rear of the unit heats up during use.
- To avoid short-circuit: before you connect, ensure that the ignition is off.
- Ensure that you connect the yellow and red power supply leads after all other leads are connected.
- Ensure that all loose leads are insulated with electrical tape.
- Ensure that the leads do not get caught under screws or in parts that will move (e.g. seat rail).
- Ensure that all ground (earth) leads are run to a common ground (earth) point.
- Use only the supplied mounting hardware for a safe and secure installation.
- Improper fuses can cause damage or fire. When you need to change the fuse, consult a professional.

## Note on the power supply lead (yellow)

- When you connect other devices to this system, ensure that the rating of the car circuit is higher than the total fuse value of all the connected devices.

## Notes on speaker connection

- Never connect speaker wires to the metal body or chassis of the car.
- Never connect speaker wires with stripes to one another.

## Connect wires: ISO male connectors

## ! Caution

- Ensure that all loose leads are insulated with electrical tape.

## ≡ Note

- Consult a professional to connect CE130 as instructed below.

- 1 Connect the supplied male connector to the unit.

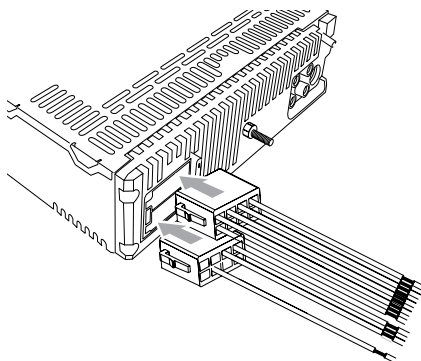

- 2 Check the car's wiring carefully and connect them to the supplied male connector.

## ≡ Note

- Risk of danger! Please consult a professional to perform the below steps!



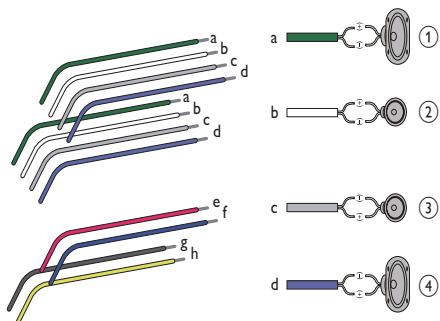

|   | Connector                 | Connect to          |
|---|---------------------------|---------------------|
| 1 | ANTENNA                   | Antenna             |
| 2 | FRONT LINE OUT R (Socket) | Front right speaker |
| 3 | FRONT LINE OUT L (Socket) | Front left speaker  |
| 4 | REAR LINE OUT R (Socket)  | Rear right speaker  |
| 5 | REAR LINE OUT L (Socket)  | Rear left speaker   |

### Tip

- The pin arrangement for the ISO connectors depends on the type of vehicle you drive. Be sure to make proper connections to prevent damage to the unit.

|   |                        |  |
|---|------------------------|--|
| 1 | Green/<br>black strip  | Left speaker (Rear)  |
| 2 | White/<br>black strip  | Left speaker (Front)   |
| 3 | Gray/black<br>strip    | Right speaker (Front)  |
| 4 | Purple/<br>black strip | Right speaker (Rear)   |
| e | Red                    | Ignition key +12V DC<br>when ON/ACC  |
| f | Blue                   | Motor/electric antenna<br>relay control lead/<br>Amplifier relay control<br>lead |
| g | Black                  | Ground   |
| h | Yellow                 | To the +12V car<br>battery which is<br>energized at all times                    |

## Mount into the dashboard

- If the car does not have an on-board drive or navigation computer, disconnect the negative terminal of the car battery.
  - If you disconnect the car battery in a car that has an on-board drive or navigation computer, the computer may lose its memory.
  - If the car battery is not disconnected, to avoid short-circuit, ensure that the bare wires do not touch each other.
- Ensure that car dashboard opening is within these measurements:

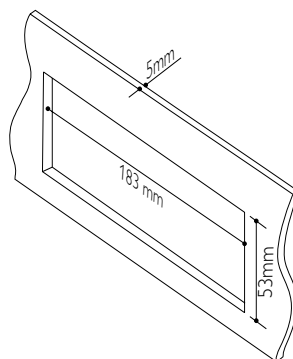

- Connect the antenna and amplifier as illustrated, if applicable.

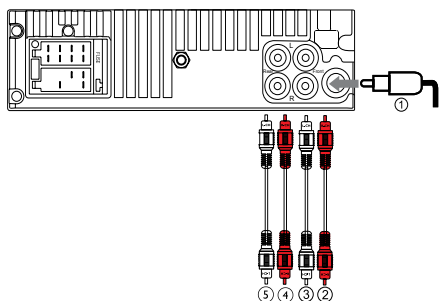

- 3 Remove the mounting sleeve with the supplied disassembly tools.

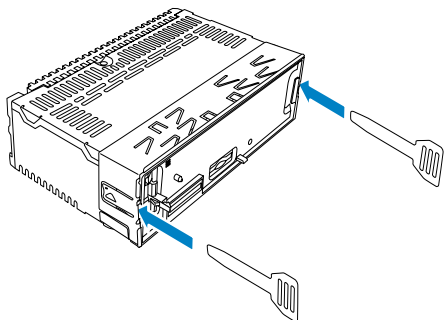

- 4 Install the sleeve into the dashboard and bend the tabs outward to fix the sleeve.

#### Note

- If the unit is not fixed by sleeve but by the supplied screws, skip this step.

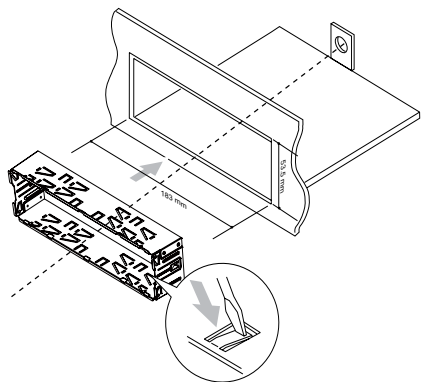

- 5 Place the supplied rubber cushion over the end of the mounting bolt.

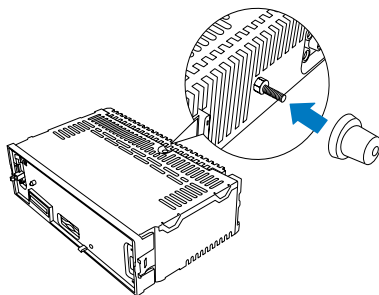

- 6 Slide the unit into the dashboard until you hear a click sound.

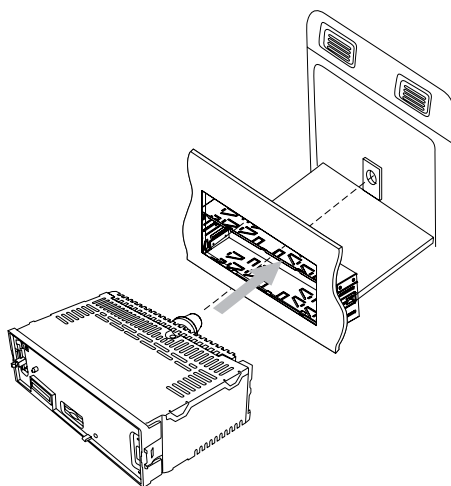

- 7 Reconnect the negative terminal of the car battery.

## Attach the front panel

- 1 Attach the trim plate.

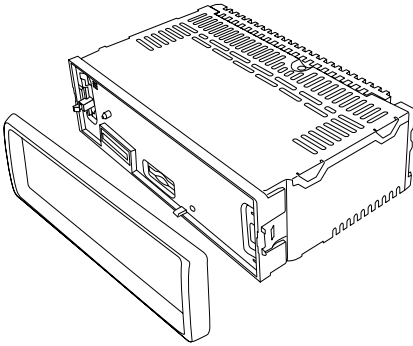

- 2 Insert the right side of the panel in the chassis until it is correctly engaged.

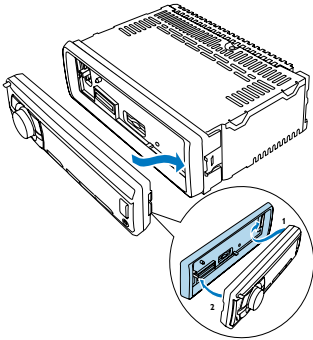

- 3 Press the left side of the panel until it is locked into place.

---

## Turn on

- 1 Press **⏻** to turn on the unit.
  - To turn off the unit, press **⏻** for over 3 seconds.

---

## Set clock

- 1 Press **MENU**.
- 2 Press **⏪** repeatedly until the current time is displayed.
- 3 Rotate **⏻** clockwise to set hour.

- 4 Press **⏻** to confirm.
- 5 Rotate **⏻** counterclockwise to set minute.
- 6 Press **⏻** to confirm.

---

## View clock

- 1 Press and hold **OPTIONS** repeatedly until the clock is displayed.

## 4 Listen to radio

### Tune to a radio station

- 1 Press **SOURCE** repeatedly to select radio mode.
- 2 Press **BAND/** to select band: **[FM1]**, **[FM2]**, **[FM3]**, **[AW1]** or **[AW2]**.
- 3 Press **◀◀** or **▶▶** to tune to a radio station manually.
  - ↳ The radio station is broadcast.
  - ↳ To search for a radio station automatically, press **◀◀** or **▶▶** for over 3 seconds.

### Select tuner region

You can select suitable country/region of the radio.

- 1 Press **SOURCE** to select Radio mode.
- 2 Press **MENU**.
- 3 Press **◀▶▶** repeatedly until **[AREA]** displays.
- 4 Rotate **⊙** to select:
  - **[USA]**
  - **[LATIN]**
  - **[Europe]**
  - **[OIRT]**

### Select tuner sensitivity

To receive more radio stations or only stations with strong signal, you can adjust the tuner sensitivity.

- 1 Press **OPTIONS** repeatedly to select **[LOCAL SEEK]**.
- 2 Rotate **⊙** to select a setting:
  - **[LOCAL SEEK ON]**: Only stations with strong signal can be broadcast.
  - **[LOCAL SEEK OFF]**: Stations with strong and weak signals can be broadcast.

## Store radio stations in memory

You can store up to 6 stations in each band.

### Store stations automatically

- 1 Press **OPTIONS** repeatedly until **[AUTO-STORE]** displays.
- 2 Press **⊙** to confirm.
  - ↳ The six strongest stations of the selected band are saved in preset channel automatically.

### Store stations manually

- 1 Tune to a preset station (see 'Tune to a preset station' on page 13)
- 2 Press and hold **+ / PRESET** or **- / RRESET** to enter storing mode.
  - ↳ The preset number starts to blink..
- 3 Press **+ / PRESET** or **- / RRESET** to select radio channel.
- 4 Press **⊙** to confirm.
  - ↳ The station is saved in the selected channel.
  - ↳ The preset number on LCD screen lights up and remains on.

## Tune to a preset station

- 1 Press **BAND/** to select band.
- 2 Press **+ / PRESET** or **- / RRESET** to select the preset station.

# 5 Play audio files

## Play from USB

### Note

- Ensure that the USB device contains playable music.

## Insert the USB device

- 1 Slide the USB socket cover marked  to the left.
- 2 Insert the USB device into the USB socket.  
↳ The unit starts to play from the USB device automatically.

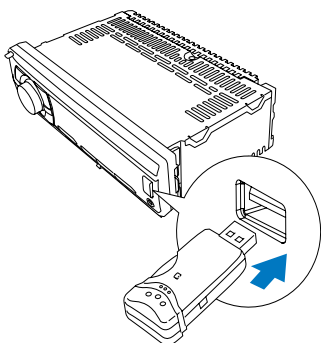

## Remove the USB device

- 1 Press  to turn off the unit.
- 2 Remove the USB device.

## Insert a card

### Note

- This unit supports SD and SDHC cards.



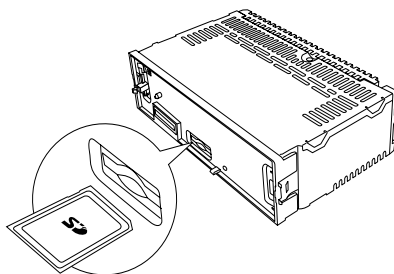

- 1 Press  to release the panel.
- 2 Push the left side of the panel rightward, then pull the panel towards you to disengage it from the chassis.
- 3 Insert the card into the card slot.  
↳ The unit starts playing from the card automatically.



## Remove the card

- 1 Press  to turn off the unit.
- 2 Press the card until you hear a click sound.  
↳ The card is now disengaged.
- 3 Remove the card.

## Play options

- To pause, press .
- To resume play, press  again.
- To skip to the previous/next track, press .
- To search backward/forward rapidly within the current track, press  for 3 seconds.

## Search for an MP3/WMA track

### Search within the current folder

- 1 Press **+SONG**.
  - ↳ The name of the current track is displayed.
- 2 Rotate  $\odot$  to select another track in current folder.
- 3 Press  $\odot$  to confirm.

### Search in other folder

- 1 Press **FOLDER -**.
  - ↳ The name of the current folder is displayed.
- 2 Rotate  $\odot$  to navigate through all folders.
- 3 Press  $\odot$  to access the selected folder.
- 4 Rotate  $\odot$  to select a track in the folder.
- 5 Press  $\odot$  to start play.



Tip

- To go back to upper level of a folder, press  $\leftarrow$ .

## View play information

- 1 During playing, press **DISP** repeatedly to view:
  - Track number and elapsed play time
  - Folder
  - File
  - Title
  - Album
  - Artist

## Repeat play

- 1 During play, press **OPTIONS** repeatedly until **[REPEAT]** is displayed.
- 2 Rotate  $\odot$  to select a setting.
  - **[REPEAT ALL]**: play all tracks repeatedly.
  - **[REPEAT TRK]**: play current track repeatedly.

- **[REPEAT FLD]**: play all tracks in the current folder repeatedly.

## Shuffle play

You can play the tracks in random order:

- 1 During play, press **OPTIONS** repeatedly until **[RANDOM]** is displayed.
- 2 Rotate  $\odot$  to select a setting:
  - **[RANDOM OFF]**: Turn off random play.
  - **[RANDOM FLD]**: start random play for all tracks in the current folder.
  - **[RANDOM ALL]**: start random play for all tracks.

## Intro play

You can play the first 10 seconds of each track.

- 1 During play, press **OPTIONS** repeatedly until **[INTRO]** is displayed.
- 2 Rotate  $\odot$  to select a setting:
  - **[INTRO OFF]**: Cancel intro play and start normal play.
  - **[INTRO FLD]**: Start intro play in the current folder.
  - **[INTRO ALL]**: Play the first 10 seconds of each track.

## Connect external sound source

- 1 Connect the external sound source to **MP3 LINK** socket with a 3.5 mm cable.
- 2 Press **SOURCE** repeatedly until **[MP3 LINK]** is displayed.
- 3 Operate the external component (refer to the instructions supplied with the external component).

# 6 Adjust sound

---

## Adjust volume

- 1 Turn  $\odot$  clockwise/counterclockwise to increase/decrease volume.

## Mute

You can turn off the sound of your audio.

- 1 During play, press  $\odot$ .
  - To resume sound, press  $\odot$  again.

## Turn on/off Max Sound

- 1 Press **MAX SOUND**.
  - ↳ The current setting is displayed.
  - ↳ **[MAX ON]**:The maximum sound (max sound) function is on.
  - ↳ **[MAX OFF]**:The maximum sound function is off.

## Turn Dynamic Bass Boost (DBB) on/off

- 1 Press **DBB** and the current setting is displayed:
  - ↳ **[DBB ON]** :The Dynamic Bass Boost (DBB) function is on.
  - ↳ **[DBB OFF]** :The DBB function is off.
- 2 Press **DBB** again to change the DBB setting.

## Select preset equalizer

- 1 Press **EQ/Audio**.
  - ↳ Current Equalizer setting is displayed.

- 2 Press **EQ/Audio** again to select a preset EQ setting:
  - **[OPTIMAL]** (optimal)
  - **[FLAT]** (flat)
  - **[POP]** (pop)
  - **[USER]** (user)
  - **[TECHNO]** (techno)
  - **[ROCK]** (rock)
  - **[CLASSIC]** (classic)
  - **[JAZZ]** (jazz)

## Switch music listening zone

Philips' innovative Zone technology enables driver or passengers to enjoy music with the best speakers balance and experience more vivid spacial effect as the artist is intended to create. You can switch the music listening zone from driver to passengers for the best speaker sound settings in car.

- 1 Press **ZONE**.
  - ↳ The current setting is displayed.
- 2 Rotate  $\odot$  to select a setting:
  - **[ZONE ALL]**
  - **[FRONT]**
  - **[F. LEFT]** (Front left)
  - **[F. RIGHT]** (Front right)
- 3 Press **OK** to confirm the selection.

## Other sound settings

You can also adjust the preset **EQ/Audio** settings.

- 1 Press **EQ/Audio** for 3 seconds.
- 2 Press **◀▶** repeatedly to select the item to be adjusted:
  - **[BAS]** (Bass) range: -7 to +7
  - **[TRE]** (Treble) range: -7 to +7
  - **[BAL]** (Balance) range: 12L to 12R. (L= left speaker, R = right speaker)
  - **[FAD]** (Fader) range: 12R to 12F. (R = rear speaker, F = front speaker)
- 3 Rotate  $\odot$  to select a value/option.





# 8 Additional information

## Detach the front panel

You can detach the front panel to deter theft.

- 1 Press  to release the panel.
- 2 Push the left side of the panel rightward.

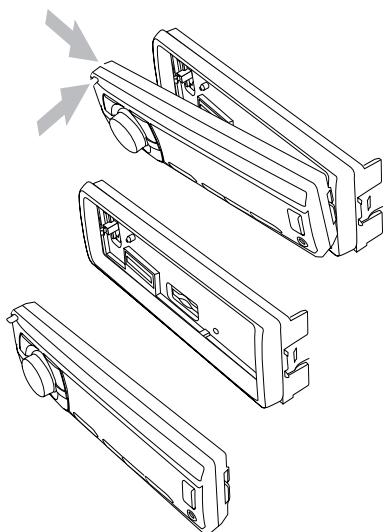

- 3 Pull the panel towards you to disengage it from the chassis.
- 4 Store the panel in the supplied carry case to protect it from dirt or damage.

## Replace fuse

If the fuse is damaged,

- 1 Check the electric connection.
- 2 Buy a fuse that matches the voltage of the damaged fuse.
- 3 Replace the fuse.

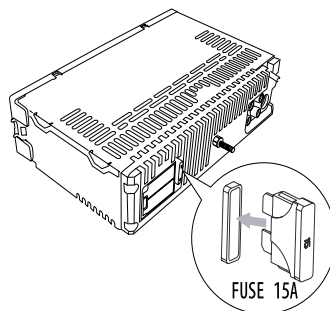

### Note

- If the new fuse gets damaged again, there may be an internal malfunction. Consult your Philips dealer.

## Remove the unit

You can remove the unit from the dashboard.

- 1 Detach the front panel and the trim plate.
- 2 Pull out the unit by using the disassembly tools.

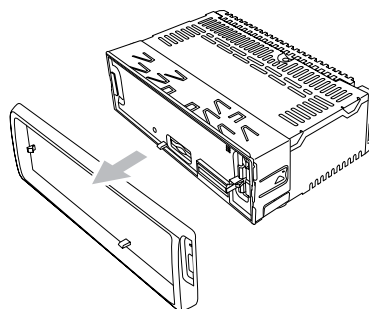

# 9 Product information

## Note

- Product information is subject to change without prior notice.

|                                      |   |
|--------------------------------------|---|
| Power supply                         | 12 V DC (11 V - 16 V), negative ground      |
| Fuse                                 | 15 A  |
| Suitable speaker impedance           | 4 - 8 $\Omega$                              |
| Maximum power output                 | 45 W $\times$ 4 channels                    |
| Continuous power output              | 22 W $\times$ 4 RMS (4 $\Omega$ 10% T.H.D.) |
| Pre-Amp output voltage               | 2.5 V                                       |
| Aux-in level                         | $\geq$ 500 mV                               |
| Dimensions (W $\times$ H $\times$ D) | 188 $\times$ 58 $\times$ 140 mm             |
| Weight                               | 0.8 kg                                      |

## Radio

|   |   |
|---|---|
| Frequency range - FM                      | 87.5 - 108.0 MHz (100kHz per step in auto search and 50kHz per step in manual search) |
| Frequency range - AM (MW)                 | 522 - 1620 KHz (9 kHz)<br>530 - 1710 kHz (10 kHz)                                     |
| Usable sensitivity - FM                   | 8 $\mu$ V   |
| Usable sensitivity - AM(MW) (S/N = 20 dB) | 30 $\mu$ V  |

## Compatible USB devices:

- USB flash memory: USB 1.1 host with interface reading all speed support (1.1, 2.0)
- USB flash players: USB 1.1 host with interface reading all speed support (1.1, 2.0)
- Memory cards (SD / SDHC)

## Supported formats:

- USB or memory file format: FAT16, FAT32
- MP3 bit rate (data rate): 32-320 Kbps and variable bit rate
- WMA V4, V7, V8, V9 (L1, L2)
- ISO9660, Joliet
- Maximum title number: 512 (depending on file name length)
- Maximum album number: 255
- Supported sampling frequencies: 2 kHz, 44.1 kHz, 48 kHz
- Supported Bit-rates: 2~256 (kbps), variable bit rates
- Directory nesting up to a maximum of 8 levels
- Number of albums/ folders: CD maximum 99, USB maximum 199
- Number of tracks/titles: maximum 999
- ID3 tag v2.0 to v2.4
- File name in Unicode UTF8 (maximum length 64 bytes)

# 10 Troubleshooting

## Caution

- Never remove the casing of this apparatus.

To keep the warranty valid, never try to repair the system yourself.

If you encounter problems when using this apparatus, check the following points before requesting service. If the problem remains unsolved, go to the Philips web site ([www.philips.com/support](http://www.philips.com/support)). When you contact Philips, ensure that your apparatus is nearby and the model number and serial number are available.

### **No power or no sound.**

- Car engine is not on. Turn the car engine on.
- Cable is not correctly connected. Check connections.
- Fuse is burnt. Replace fuse.
- Volume is too low. Adjust volume.
- If the above solutions cannot help, press the RESET button.
- Ensure that the track played is of a compatible format.

### **Noise in broadcasts.**

- Signals are too weak. Select other stations with stronger signals.
- Check the connection of the car antenna.
- Change broadcast from Stereo to mono.

### **Preset stations lost.**

- Battery cable is not correctly connected. Connect the battery cable to the terminal that is always live.

### **Display show ERR-12**

- USB data error. Check the USB device.

### **Display show ERR-3**

- USB/SD data error.

# 11 Glossary

---

## M

### **MP3**

A file format with a sound data compression system. MP3 is the abbreviation of Motion Picture Experts Group 1 (or MPEG-1) Audio Layer 3. With the MP3 format, one CD-R or CD-RW can contain about 10 times more data than a regular CD.

---

## S

### **SD**

Secure Digital. A type of memory card with a flash memory.

### **SDHC**

Secure Digital High Capacity (SDHC) is a type of flash memory card based on the SDA 2.00 specification. The SDA 2.00 specification enables SD cards to reach higher capacities from 4GB to 32GB, and growing.

---

## W

### **WMA (Windows Media Audio)**

An audio format owned by Microsoft, is a part of Microsoft Windows Media technology. Includes Microsoft Digital Rights Management tools, Windows Media Video encoding technology, and Windows Media Audio encoding technology.

