

Always there to help you

Register your product and get support at
www.philips.com/welcome



CEM5200/51



User manual 1

Руководство пользователя 29

PHILIPS

Contents

1 Important	2	7 Adjust sound	20
Safety	2	Adjust volume	20
Notice	2	Mute	20
2 Your car audio system	4	Turn Dynamic Bass Boost (DBB) on/off	20
Introduction	4	Turn MAX sound on/off	20
What's in the box	4	Select preset equalizer	21
Overview of the main unit	5	Switch music listening zone	21
Overview of the remote control	7	Turn on/off full sound	21
3 Get started	7	Other sound settings	21
Install the car audio	7	8 Adjust system settings	22
Install remote control battery	11	Turn beep sound on/off	22
Turn on	11	Select blackout setting	22
Select country/region	11	Turn demo mode on/off	22
Set clock	11	Dimmer	22
4 Listen to radio	12	Dance	22
Tune to a radio station	12	LCD Color	22
Store radio stations in memory	13	Audiobook	23
Tune to a preset station	13	Reset	23
Play with RDS	13	9 Additional information	24
5 Use Bluetooth devices	15	Detach the front panel	24
Pairing Bluetooth devices	15	Replace fuse	24
Make a call	16	Remove the unit	24
Call transfer	16	10 Product information	25
Receive call	16	11 Troubleshooting	26
Terminate call	16	About Bluetooth device	27
Play audio files from Bluetooth devices	16	12 Glossary	28
6 Play audio files	17		
Play a disc	17		
Play from USB	17		
Insert a card	17		
Play from iPod/iPhone	18		
Play options	19		
Connect external sound source	20		

1 Important

Safety

- Read and understand all instructions before you use your apparatus. If damage is caused by failure to follow instructions, the warranty does not apply.
- This apparatus is designed for negative ground (earth) 12V DC operation only.
- To ensure safe driving, adjust the volume to a safe and comfortable level.
- Improper fuses can cause damage or fire. When you need to change the fuse, consult a professional.
- Use only the supplied mounting hardware for a safe and secure installation.
- To avoid short circuit, do not expose the apparatus, remote control or remote control batteries to rain or water.
- Never insert objects into the ventilation slots or other openings on the apparatus.
- Clean the apparatus and frame with a soft, damp cloth. Never use substances such as alcohol, chemicals or household cleaners on the apparatus.
- Never place any objects other than discs into the apparatus.
- Never use solvents such as benzene, thinner, cleaners available commercially, or anti-static sprays intended for discs.
- Visible and invisible laser radiation when open. Avoid exposure to beam.
- Risk of damage to the apparatus screen! Never touch, push, rub or strike the screen with any object.

Risk of swallowing batteries!

- The product or remote control may contain a button cell battery, which is possible to be swallowed. Keep the battery out of reach of children at all times! If swallowed, the battery can cause serious

injury or death. Severe internal burns can occur within two hours of ingestion.

- If you suspect that a battery has been swallowed or placed inside any part of the body, seek immediate medical attention.
- When you change the batteries, always keep all new and used batteries out of reach of children. Ensure that the battery compartment is completely secure after you replace the battery.
- If the battery compartment cannot be completely secured, discontinue use of the product. Keep out of reach of children and contact the manufacturer.



Caution

- Use of controls or adjustments or performance of procedures other than herein may result in hazardous radiation exposure or other unsafe operation.
- The apparatus shall not be exposed to dripping or splashing.
- Do not place any sources of danger on the apparatus (e.g. liquid filled objects, lighted candles).

Notice

Any changes or modifications made to this device that are not expressly approved by Philips Consumer Lifestyle may void the user's authority to operate the equipment.

Recycling



Your product is designed and manufactured with high quality materials and components, which can be recycled and reused.

When you see the crossed-out wheel bin symbol attached to a product, it means the product is covered by the European Directive 2002/96/EC:



Never dispose of your product with other household waste. Please inform yourself about the local rules on the separate collection of electrical and electronic products. The correct disposal of your old product helps prevent potentially negative consequences on the environment and human health.

Your product contains batteries covered by the European Directive 2006/66/EC, which cannot be disposed of with normal household waste.

Please inform yourself about the local rules on separate collection of batteries. The correct disposal of batteries helps prevent potentially negative consequences on the environment and human health.

Environmental information

All unnecessary packaging has been omitted. We have tried to make the packaging easy to separate into three materials: cardboard (box), polystyrene foam (buffer) and polyethylene (bags, protective foam sheet.)

Your system consists of materials which can be recycled and reused if disassembled by a specialized company. Please observe the local regulations regarding the disposal of packaging materials, exhausted batteries and old equipment.



The making of unauthorized copies of copy-protected material, including computer programs, files, broadcasts and sound recordings, may be an infringement of copyrights and constitute a criminal offence. This equipment should not be used for such purposes.



Windows Media and the Windows logo are trademarks, or registered trademarks of Microsoft Corporation in the United States and/or other countries.

"Made for iPod" and "Made for iPhone" mean that an electronic accessory has been designed to connect specifically to iPod, or iPhone respectively, and has been certified by the developer to meet Apple performance standards. Apple is not responsible for the operation of this device or its compliance with



safety and regulatory standards. Please note that the use of this accessory with iPod, or iPhone may affect wireless performance.

Apple is not responsible for the operation of this device or its compliance with safety and regulatory standards.

iPod and iPhone are trademarks of Apple Inc., registered in the U.S. and other countries.

This apparatus includes this label:

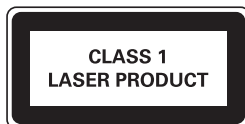

2013 © Koninklijke Philips Electronics N.V. All rights reserved.

Specifications are subject to change without notice. Trademarks are the property of Koninklijke Philips Electronics N.V. or their respective owners. Philips reserves the right to change products at any time without being obliged to adjust earlier supplies accordingly.

2 Your car audio system

Congratulations on your purchase, and welcome to Philips! To fully benefit from the support that Philips offers, register your product at www.philips.com/welcome.

Introduction

With the in-car audio system, you can enjoy your drive while you listen to:

- FM or AM (MW) radio
- Audio from CD or MP3 disc
- Audio from your mobile phone
- Audio from a USB drive
- Audio from a SD/SDHC card
- Audio from external devices

Besides, you can make a call, answer and hang up a call on the audio system.

What's in the box

Check and identify the contents of your package:

- ① Main unit (with a sleeve)
- ② Remote control
- ③ Front panel
- ④ Trim plate
- ⑤ Carrying case for front panel
- ⑥ ISO male connector
- ⑦ Rubber cushion
- ⑧ Screw x 1 pc
- ⑨ Disassembly tools x 2 pcs
- ⑩ User manual

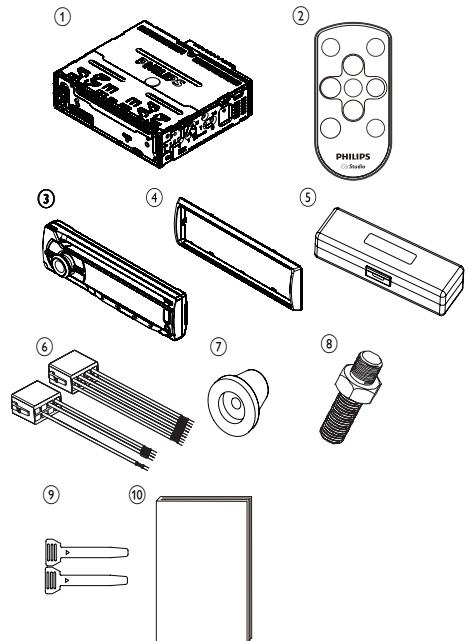

Overview of the main unit

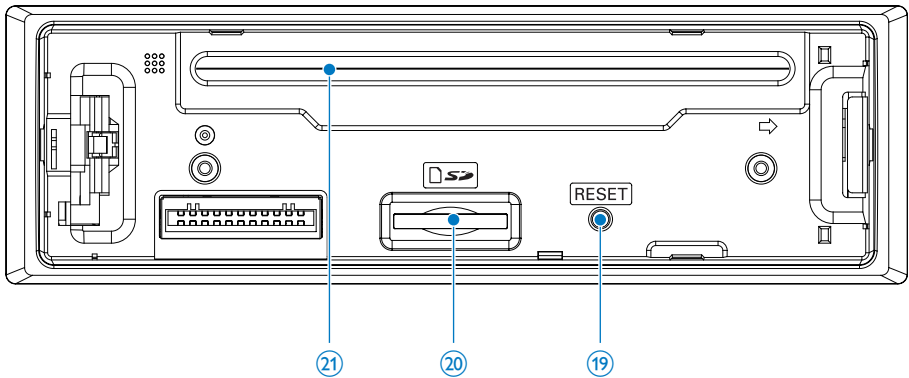
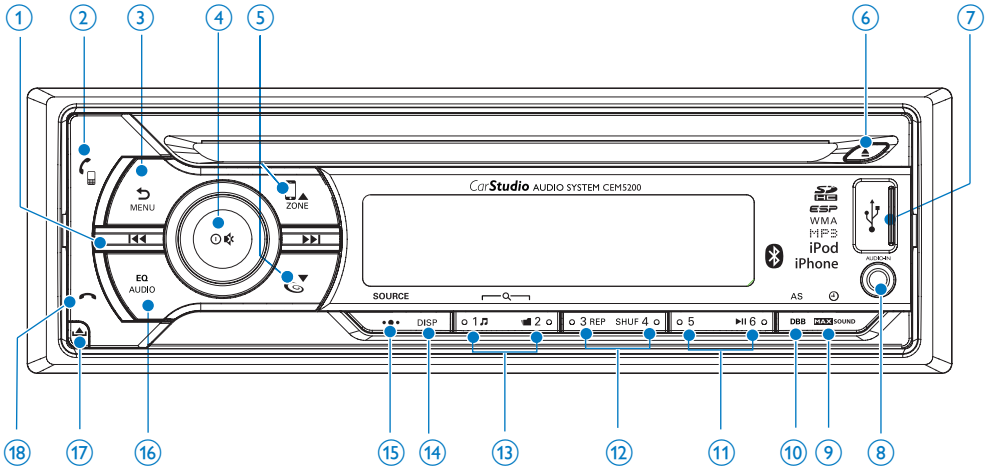

① ⏮ / ⏭

- Tune for radio station.
- Skip/search for track.
- Press and hold to fast backward/forward playback.

2 📞

- Press to answer or redial a call.
- Press and hold to transfer call.

③ MENU ↵

- Press and hold to access system menu.
- Return to previous menu.

- Access music search in iPod/iPhone mode.

④ ⏻ / 🔊

- Turn the unit on or off.
- Confirm selection.
- Mute or unmute sound.
- Rotate to adjust volume.

⑤ ⏪ ▲ ZONE / ▼ 🔊

- Select tuner band.
- Select MP3/WMA folder.
- Press and hold to switch music listening zone.

- Turn on or off full sound.
- Enter iPod/iPhone control mode.

⑥ ▲

- Eject disc.

⑦ ↵

- USB socket.

⑧ **AUDIO IN**

- Connect external audio device.

⑨ **MAX SOUND** / 

- Press to turn on or off Maximizing volume.
- In any mode, press and hold to view clock.

⑩ **DBB/AS**

- Press to turn on or off Dynamic Bass Boost (DBB) sound.
- In radio mode, press and hold to access to tuner auto store.

⑪ ▶||

- Start, pause, or resume the play of tracks.
- In radio mode, press to select the preset radio station of No. 5/6.
- In radio mode, press and hold to store the current radio station at channel No. 5/6.

⑫ **REP / SHUF**

- In radio mode, press to select the preset radio station of No. 3/4.
- In radio mode, press and hold to store the current radio station at channel No. 3/4.
- For .wma and .mp3 tracks, press repeatedly to select shuffle play/repeat play.

⑬  / 

- In radio mode, press to select the preset radio station of No. 1/2.
- In radio mode, press and hold to store the current radio station at channel No. 1/2.
- For .wma and .mp3 tracks on a storage device, press to access the track/folder list.

⑭ **DISP**

- Display current status.
- Select the dimmer high or low.

⑮ **SOURCE**

- Select audio source.
- Display LCD color.

⑯ **EQ / AUDIO**

- Select equalizer (EQ) setting.
- Access audio setting menu.

⑰ 

- Unlock the panel.

⑱ 

- Press to terminate call.

⑲ **RESET**

- Restore default settings.

⑳ **SD card slot**

㉑ **Disc slot**

Overview of the remote control

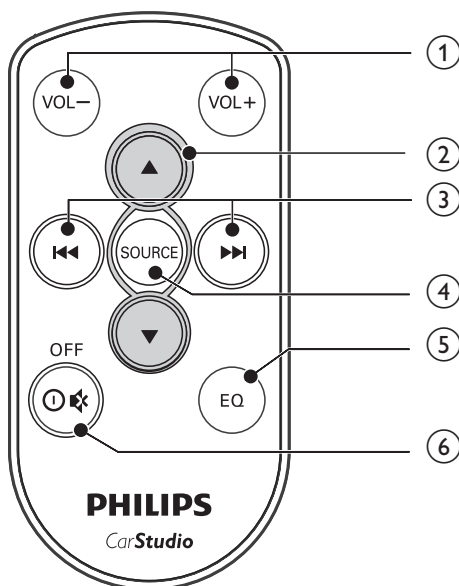

- ① VOL +/-
 - Adjust volume.
- ② ▲ / ▼
 - Select tuner band.
 - Scroll up/down menu.
 - Select MP3/WMA folder.
- ③ ◀◀ / ▶▶
 - Tune to a radio station
 - Skip track.
 - Fast backward/forward playback
- ④ SOURCE
 - Select audio source.
- ⑤ EQ
 - Select equalizer (EQ) settings.
- ⑥ OFF / Ⓜ / 🔊
 - Turn the unit on or off.
 - Mute or restore volume.

3 Get started



Caution

- Use the controls only as stated in this user manual.

Always follow the instructions in this chapter in sequence.

If you contact Philips, you will be asked for the model and serial number of your apparatus. The model number and serial number are on the bottom of your apparatus. Write the numbers here:

Model No. _____

Serial No. _____

Install the car audio

These instructions are for a typical installation. However, if your car has different requirements, make the corresponding adjustment. If you have any questions regarding installation kits, consult your Philips car audio dealer.



Caution

- This unit is designed for negative ground (earth) 12V DC operation only.
- Always install this unit in the car dashboard. Other locations can be dangerous as the rear of the unit heats up during use.
- To avoid short-circuit before you connect, ensure that the ignition is off.
- Ensure that you connect the yellow and red power supply leads after all other leads are connected.
- Ensure that all loose leads are insulated with electrical tape.
- Ensure that the leads do not get caught under screws or in parts that will move (e.g. seat rail).
- Ensure that all ground (earth) leads are run to a common ground (earth) point.
- Use only the supplied mounting hardware for a safe and secure installation.
- Improper fuses can cause damage or fire. When you need to change the fuse, consult a professional.

Note on the power supply lead (yellow)

- When you connect other devices to this apparatus, ensure that the rating of the car circuit is higher than the total fuse value of all the connected devices.

Notes on speaker connection

- Never connect speaker wires to the metal body or chassis of the car.
- Never connect speaker wires with stripes to one another.

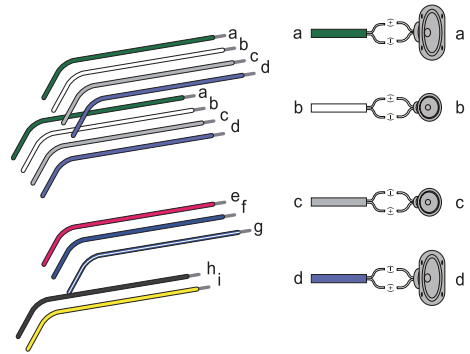

Connection: for cars with ISO connectors

Caution

- Ensure that all loose leads are insulated with electrical tape.

Note

- Consult a professional to connect CEM5200 as instructed below.

- 1 Connect the supplied male connector to the unit.

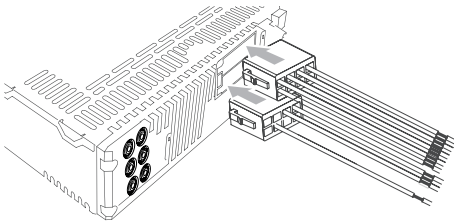

- 2 Check the car's wiring carefully and connect them to the the supplied male connector.

Note

- Risk of danger! Please consult a professional to perform the steps below!

1	Green/black strip	Left speaker (Rear)
2	White/black strip	Left speaker (Front)
3	Gray/black strip	Right speaker (Front)
4	Purple/black strip	Right speaker (Rear)
e	Red	Ignition key +12V DC when ON/ACC
f	Blue	Motor/electric antenna relay control lead
g	Blue/white	Amplifier relay control lead
h	Black	Ground
i	Yellow	To the +12V car battery which is energized at all times

- 3 Connect the antenna and amplifier as illustrated, if applicable.

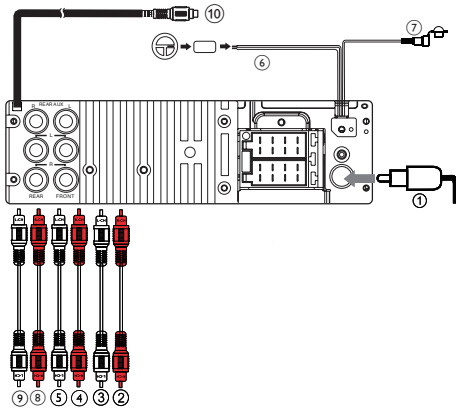

Connector	Connect to
1 ANTENNA	Antenna
2 FRONT LINE OUT R (Socket)	Front right speaker
3 FRONT LINE OUT L (Socket)	Front left speaker
4 REAR LINE OUT R (Socket)	Rear right speaker
5 REAR LINE OUT L (Socket)	Rear left speaker
6 OE REMOTE (Purple)	OE Remote
7 SUBWOOFER (Blue)	Subwoofer
8 REAR AUX LINE OUT R	Rear Aux right
9 REAR AUX LINE OUT L	Rear Aux left
10 External Mic	An external microphone for phone calls

Tip

- The pin arrangement for the ISO connectors depends on the type of vehicle you drive. Be sure to make proper connections to prevent damage to the unit.

Mount into the dashboard

- If the car does not have an on-board drive or navigation computer, disconnect the negative terminal of the car battery.
 - If you disconnect the car battery in a car that has an on-board drive or navigation computer, the computer may lose its memory.
 - If the car battery is not disconnected, to avoid short-circuit, ensure that the bare wires do not touch each other.
- Ensure that car dashboard opening is within these measurements:

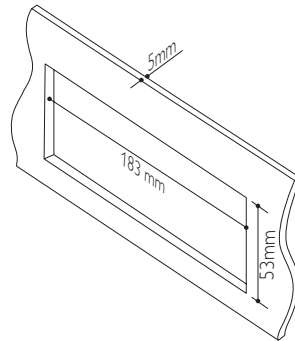

- Remove the mounting sleeve with the supplied disassembly tools.

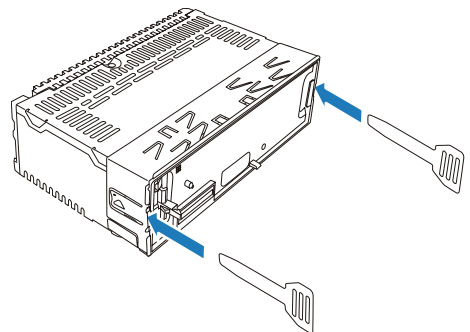

- 4 Install the sleeve into the dashboard and bend the tabs outward to fix the sleeve.

Note

- If the unit is not fixed by sleeve but by the supplied screws, skip this step.

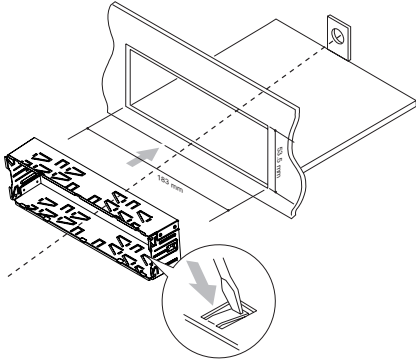

- 5 Place the supplied rubber cushion over the end of the mounting bolt.

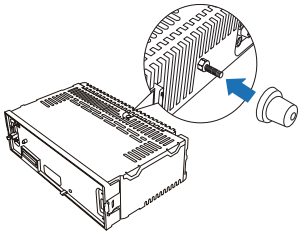

- 6 Slide the unit into the dashboard until you hear a click.

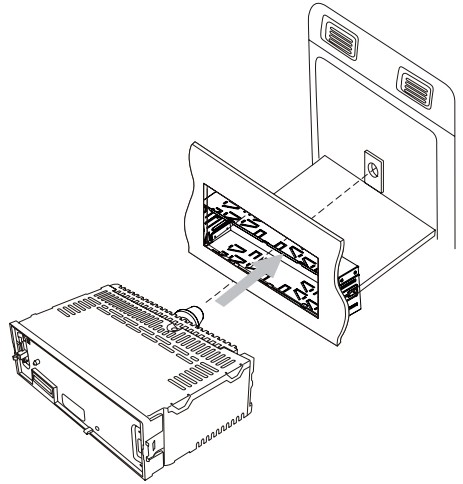

- 7 Reconnect the negative terminal of the car battery.

Attach the front panel

- 1 Attach the trim plate.
- 2 Insert the right side of the panel in the chassis until it is correctly engaged.
- 3 Press the left side of the panel until the mechanism locks it into place.

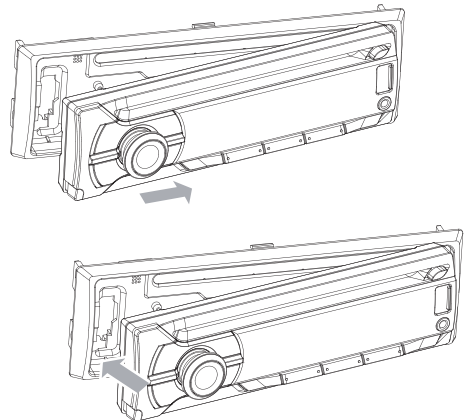

Install remote control battery

! Caution

- Risk of explosion! Keep batteries away from heat, sunshine or fire. Never discard batteries in fire.
- Risk of decreased battery life! Never mix different brands or types of batteries.
- Risk of product damage! When the remote control is not used for long periods, remove the batteries.
- Perchlorate Material - special handling may apply. See www.dtsc.ca.gov/hazardouswaste/perchlorate.

For first-time use:

Remove the protective tab to activate the remote control battery.

To replace the remote control battery:

- 1 Open the battery compartment.
- 2 Insert one CR2025 battery with correct polarity (+/-) as indicated.
- 3 Close the battery compartment.

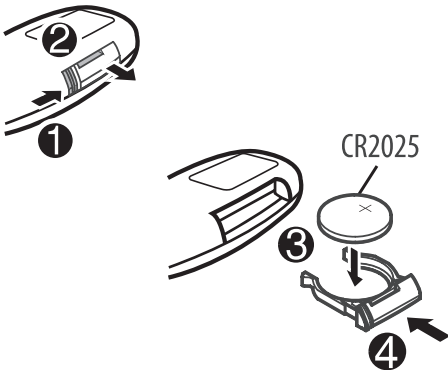

Turn on

To turn the unit on,

- press **⏻**.

To turn the unit off,

- press and hold **⏻** until the unit is turned off.

Select country/region

☰ Note

- Select correct country/region for this unit, otherwise the unit can not work properly.

- 1 Press **⏻** to turn the unit on.
↳ **[SELECT OPERATING REGION]** is displayed.
- 2 Rotate **⏻** to select an option:
 - **[USA]** (United States)
 - **[LATIN]** (Latin America)
 - **[EUROPE]** (Western Europe)
 - **[RUS]** (Russia)
 - **[M-EAST]** (Middle East)
 - **[ASIA]** (Asia Pacific)
 - **[JAP]** (Japan)
 - **[AUST]** (Australia)
 - **[OIRT]** (OIRT)
- 3 Press **⏻** to confirm.

Set clock

- 1 Press **MENU** repeatedly until current time is flashed.
- 2 Rotate **⏻** to set hour.
- 3 Press **⏻** to confirm.
- 4 Rotate **⏻** to set minute.
- 5 Press **⏻** to confirm.

Set clock format

- 1 Press **MENU**.
- 2 Press **▲** or **▼** repeatedly until **[CLOCK FORMAT]** is displayed.
- 3 Rotate **⊖** to select a setting:
 - **[CLOCK 12H]**
 - **[CLOCK 24H]**

View clock

In any mode, press and hold **MAX SOUND** until the clock is displayed.

- Press any key to cancel the clock display.

4 Listen to radio

Tune to a radio station

- 1 Press **SOURCE** repeatedly to select radio mode.
- 2 Press **▲** / **▼** repeatedly to select band: **[FM1]**, **[FM2]**, **[FM3]**, **[AM1]**, or **[AM2]** .
- 3 Press and hold **◀◀** or **▶▶** until the frequency digit is flashed.
- 4 Press **◀◀** or **▶▶** to tune to a radio station manually.
 - ↳ The radio station is broadcast.
 - To search for a radio station automatically, press **◀◀** or **▶▶**.

Select tuner region

You can select suitable country/region of the radio.

- 1 Press **SOURCE** to select radio mode.
- 2 Press and hold **MENU** repeatedly until **[AREA]** is displayed..
- 3 Rotate **⊖** to select:
 - **[USA]** (United States)
 - **[LATIN]** (Latin America)
 - **[EUROPE]** (Western Europe)
 - **[RUS]** (Russia)
 - **[M-EAST]** (Middle East)
 - **[ASIA]** (Asia Pacific)
 - **[JAP]** (Japan)
 - **[AUST]** (Australia)
 - **[OIRT]** (OIRT)
- 4 Press **⊖** to confirm.

Select tuner sensitivity

To receive more radio stations or only stations with strong signal, you can adjust the tuner sensitivity.

- 1 Press and hold **MENU** repeatedly until **[LOCAL]** is displayed.
- 2 Rotate \odot to select a setting:
 - **[LOCAL ON]** (local on): Only stations with strong signal can be broadcast.
 - **[LOCAL OFF]** (local off): Stations with strong and weak signals can be broadcast.

Store radio stations in memory

You can store up to six stations in each band.

Store stations automatically

- 1 In radio mode, press and hold **DBB** until **[STORE - - -]** is displayed.
- 2 Press \odot to confirm.
 - ↳ The six strongest stations of the selected band are saved in the preset channel automatically.

Store stations manually

- 1 Tune to a station that you want to store. (see 'Tune to a radio station' on page 13)
- 2 Press a numeric button for three seconds.
 - ↳ The station is saved in the selected channel.

Tune to a preset station

- 1 In radio mode, press \blacktriangle / \blacktriangledown to select band.
- 2 Press a numeric key to select a preset station.

Play with RDS

The RDS (Radio Data System) function operates only in areas with FM stations broadcasting RDS signals. If you tune to an RDS station, the station name are displayed.

Turn on RDS

Note

- The default setting for RDS is on.

- 1 Press **MENU**.
- 2 Press \blacktriangle or \blacktriangledown repeatedly until **[RDS]** is displayed.
- 3 Rotate \odot to select **[RDS ON]**.
 - ↳ The RDS function is turned on.

Select program type

Before tuning to RDS stations, you can select program type and let the unit search only for programs of the selected category.

- 1 Press **MENU**.
- 2 Press \blacktriangle or \blacktriangledown repeatedly until **[PTY]** is displayed.
- 3 Press \odot to confirm.
- 4 Rotate \odot to select a type, then press \odot to confirm.

Item	Program type	Description
1	NEWS	News services
2	AFFAIRS	Politics and current affairs
3	INFO	Special information programs
4	SPORT	Sports
5	EDUCATE	Education and advanced training
6	DRAMA	Radio plays and literature

Item	Program type	Description
7	CULTURE	Culture, religion and society
8	SCIENCE	Science
9	VARIED	Entertainment programs
10	POP M	Pop music
11	ROCK M	Rock music
12	EASY M	Light music
13	LIGHT M	Light classical music
14	CLASSICS	Classical music
15	OTHER M	Special music programs
16	WEATHER	Weather
17	FINANCE	Finance
18	CHILDREN	Children's programs
19	SOCIAL	Social Affairs
20	RELIGION	Religion
21	PHONE IN	Phone In
22	TRAVEL	Travel
23	LEISURE	Leisure
24	JAZZ	Jazz Music
25	COUNTRY	Country Music
26	NATION M	National Music
27	OLDIES	Oldies Music
28	FOLK M	Folk Music
29	DOCUMENT	Documentary
30	TEST	Alarm Test
31	ALARM	Alarm

Select alternate frequencies

If the radio signal is poor, turn on AF (Alternate Frequency) to search for another station with stronger signal.

- 1 Press **MENU**.
- 2 Press **▲** or **▼** repeatedly until **[AF]** is displayed.
- 3 Rotate **⊙** to select a setting:
 - **[AF ON]**: turn AF mode on.
 - **[AF OFF]**: turn AF mode off.

Set region for AF tuning

You can define AF tuning region:

[REG ON]	Only stations in current region can be tuned to automatically.
[REG OFF]	All stations can be tuned to automatically.

- 1 Press **MENU**.
- 2 Press **▲** or **▼** repeatedly until **[REG]** is displayed.
- 3 Rotate **⊙** to select a setting.

Receive traffic announcement

If you do not want to miss traffic announcement when enjoying music, turn on the TA (Traffic Announcement) function.

- 1 Press **MENU**.
- 2 Press **▲** or **▼** repeatedly until **[TA]** is displayed.
- 3 Rotate **⊙** to select a setting:
 - **[TA ON]**: when there is traffic announcement, the unit switches to the tuner mode (regardless of the current mode) and begins to broadcast the traffic conditions. When the traffic announcement is over, it returns to the previous mode.
 - **[TA OFF]**: traffic announcement does not cut in.

Note

- If the current received TA signal remains weak for over 120 seconds, the unit will activate TA Seek mode automatically. The TA Seek will seek for other station with good condition of TA signal.

Tip

- When a traffic announcement cuts in, user can short press **↵** to terminate the traffic announcement, and the unit will resume to previous playback mode.

Set RDS clock

You can use time signal that is broadcast together with the RDS signal to set the clock of the unit automatically.

- 1 Press **MENU**.
- 2 Press **▲** or **▼** repeatedly until **[CT]** is displayed.
- 3 Rotate **⊙** to select a setting:
 - **[CT ON]**: turn on the RDS clock. Time shown on the unit synchronizes with that on the RDS station.
 - **[CT OFF]**: turn off the RDS clock.



Tip

- The accuracy of the transmitted time depends on the RDS station that transmits the time signal.

5 Use Bluetooth devices

With this car audio system, you can listen to audio files from a player or make a call if Bluetooth connection is available on your phone or player.

Pairing Bluetooth devices

You can pair your Bluetooth device with the unit as follows:



Note

- For pairing operation, make sure to switch on the **[BT MODE]** on the unit.

- 1 Turn on Bluetooth function on your device.
- 2 Search for other Bluetooth devices that can pair with your device.
- 3 Select "Philips" in the pairing list.
- 4 Enter default password "0000".
 - ↳ **[PAIR OK]** is displayed on the panel if pairing is successful.
 - ↳ The paired device connect to the car audio system automatically.
- **To disconnect the Bluetooth**
 - 1 Press and hold **MENU**.
 - ↳ **[BT DISCONN]** is displayed.
 - 2 Press **⊙** / **⌂**.
 - ↳ **[DISCONN OK]** is displayed if disconnection is successful.
- **To connect the Bluetooth**
 - 1 Press and hold **MENU**.
 - ↳ **[BT CONNECT]** is displayed.

- 2 Press **⓪** / **✱**.
 - ↳ **[WAITING]** is displayed.
 - ↳ **[CONNECTED]** is displayed if connection is successful.
 - ↳ **[FAILED]** is displayed if connection is failed.

Make a call

Note

- To make an outgoing call on this unit, the Bluetooth connection between the unit and the phone must be active.

You can dial number through the mobile phone.

To make call through the mobile phone.

- 1 Use the Mobile Phone to dial and make an outgoing call.
 - 2 Once completed the dialing, **[CALLING]** is displayed.
 - **To redial number.**
- 1 Press **↶**.
 - ↳ **[REDIAL]** is displayed.
 - 2 Press **⓪** / **✱** again.
 - ↳ **[CALLING]** is displayed and the unit starts dialing the number dialed last time.

Call transfer

You can transfer voice from loudspeaker to mobile phones during call.

Press and hold **↶** until **[TRANSFER]** is displayed.

- ↳ Voice transfers from loudspeaker to mobile phone.

Receive call

- 1 If there is incoming call, the phone number is displayed.
 - if the incoming call has no phone number, **[PHONE IN]** is displayed.
- 2 Press **↶** to answer/accept the call.

Terminate call

Press **↶** to terminate call.

Play audio files from Bluetooth devices

You can listen to audio from a Bluetooth device and control playback with the unit.

Press **SOURCE** repeatedly to select **[BT AUDIO]**.

- To start play, press **▶||**.

Note

- Some mobile phone supports auto playback, no need to start play manually.
- Some mobile phone needs to open the Media Players for audio files wireless playback.

- To pause, press **▶||** again.
- To track up/down, press **◀◀** / **▶▶**.

6 Play audio files

Note

- Ensure that the disc or device contains playable files.

Play a disc

Note

- You cannot play CDs encoded with copyright protection technologies.

You can play commercially available audio CDs and these discs:

- CD-Recordables (CD-R)
- CD-Re-writables (CD-RW)
- MP3 CDs
- WMA CDs

Note

- Ensure that the disc contains playable content.

Insert a CD with the printed side facing up.

- ↳ Play starts automatically.
- To pause CD play, press **▶||**.
- To resume CD play, press **▶||** again.
- To skip to the previous/next track, press **◀◀** or **▶▶**.
- To search backward/forward rapidly within the current track, press **◀◀** or **▶▶** for 3 seconds.

Remove the CD

To take out the CD, press **▲** on the front panel.

Tip

- If the disc is blocked in the disc compartment, press and hold **▲** until the disc comes out.

Play from USB

Note

- Ensure that the USB device contains playable music.

Insert the USB device

- 1 Slide the USB socket cover marked  to the left.
- 2 Insert the USB device into the USB socket.
↳ The unit starts playing from the USB device automatically.

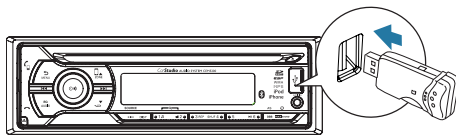

Remove the USB device

- 1 Press **⊖** to turn the unit off.
- 2 Remove the USB device.

Insert a card

Note

- This unit supports SD and SDHC cards.

- 1 Press **▲** to release the panel.
- 2 Insert the card into the card slot.
- 3 Close the front panel.
↳ The unit starts playing from the card automatically.

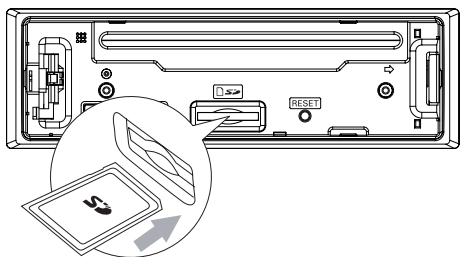

Remove the card

- 1 Press \odot to turn the unit off.
- 2 Press the card until you hear a click.
 \rightarrow The card is now disengaged.
- 3 Remove the card.

Play from iPod/iPhone

You can enjoy audio from iPod/iPhone through this unit.

Compatible iPod/iPhone

Apple iPod and iPhone models with a 30-pin dock connector:

Made for:

- iPod nano (2nd generation)
- iPod nano (3rd generation 4GB)
- iPod nano (3rd generation 8GB)
- iPod nano (4th generation)
- iPod nano (5th generation)
- iPod nano (6th generation)
- iPod classic (1st generation)
- iPod classic (2nd generation)
- iPod touch (1st generation)
- iPod touch (2nd generation)
- iPod touch (3rd generation)
- iPod video (30GB & 80GB)

Works with:

- iPhone
- iPhone 3G
- iPhone 3GS
- iPhone 4
- iPhone 4S

Connect iPod/iPhone

- 1 Slide the USB socket cover marked \leftarrow to the left.
- 2 Insert USB adaptor on one end of iPod/iPhone cable to the USB socket on the main unit.
- 3 Insert the other end of the iPod/iPhone cable to the iPod/iPhone socket.
 \rightarrow The unit starts playing from the USB device automatically.

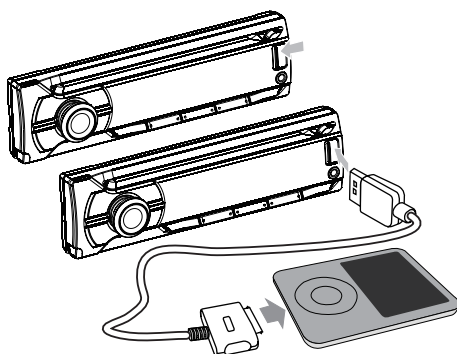

Control music playback on iPod/iPhone

- 1 Ensure that the iPod/iPhone is connected correctly.
- 2 Press **SOURCE** to select iPod USB mode.
- 3 Press \square repeatedly to toggle between the two control modes:
 - **iPod control mode:** Use the buttons/touch screen on iPod/iPhone to control the music.
 - **Audio control mode:** Use the control buttons on car audio to control the music.

To control playback under audio control mode:

- To pause/resume play, press **⏸**.
- To skip to a track, press **⏮** / **⏭**.
- To search during play, press and hold **⏮** / **⏭**, then release to resume normal play.
- To navigate the menu, press **⏪**, rotate **⌂** to select, then press **⏸** to confirm.

Search for a track

- 1 Press **SOURCE** repeatedly to select iPod mode.
- 2 Press **⏪** to browse iPod/iPhone menu.
- 3 Rotate **⌂** to select the Artist search mode, and press **⏸** to confirm.
- 4 Press **DISP** to search alphabetically.
- 5 Rotate **⌂** to select desired artist, then press **⏸** to confirm.
- 6 Rotate **⌂** to select desired song in current album.
- 7 Press **⏸** to start play.



Note

- User cannot control the music via iPod/iPhone under audio control mode.

Play options

Search for an MP3/WMA track

Search within the current folder

- 1 Press **♪**.
↳ The name of the current track is displayed.
- 2 Rotate **⌂** to select another track in current folder.
- 3 Press **⏸** to confirm.

Search in other folder

- 1 Press **⏮**.
↳ The name of the current folder is displayed.
- 2 Rotate **⌂** to navigate through all folders.
- 3 Press **⏸** to access the selected folder.
↳ The unit starts playing the first song from the selected folder automatically.



Tip

- To go back to upper level of a folder, press **⏪**.

View play information

During playing, press **DISP** repeatedly to view:

- Track number and elapsed play time
- Folder
- File
- Album
- Artist
- Title

Repeat play

- 1 During play, press **REP**.
↳ **[REPEAT]** is displayed.
- 2 Rotate **⌂** to select a setting.
 - **[REPEAT TRK]** (repeat one track): play current track repeatedly.
 - **[REPEAT FLD]** (repeat a folder): play all tracks in the current folder repeatedly.
 - **[REPEAT ALL]** (repeat all tracks): play all tracks repeatedly.

Shuffle play

You can play the tracks in random order:

- 1 During play, press **SHUF**.
↳ **[SHUFFLE]** is displayed.

- 2 Rotate \odot to select a setting:
 - **[SHUFFLE FLD]**: start random play for all tracks in the current folder.
 - **[SHUFFLE ALL]**: start random play for all tracks.
 - **[SHUFFLE OFF]** : cancel shuffle play.

Connect external sound source

- 1 Connect the external sound source to **AUDIO IN** socket with a 3.5 mm cable.
- 2 Press **SOURCE** repeatedly until **[AUDIO IN]** is displayed.
- 3 Operate the external component (refer to the instructions supplied with the external component).

7 Adjust sound

Adjust volume

Turn \odot clockwise/counterclockwise to increase/decrease volume.

Mute

You can turn off the sound of your audio.

During play, press \odot .

- To resume sound, press \odot again.

Turn Dynamic Bass Boost (DBB) on/off

- 1 Press **DBB/AS** and the current setting is displayed:
 - ↳ **[DBB ON]** : the Dynamic Bass Boost (DBB) function is on.
 - ↳ **[DBB OFF]** : the DBB function is off.
- 2 Press **DBB/AS** again to change the DBB setting.

Turn MAX sound on/off

- 1 Press **MAX SOUND** / \odot .
 - ↳ The current setting displays
 - **[MAX ON]**: the maximum sound (MAX sound) function is on.
 - **[MAX OFF]**: the maximum sound function is off.
- 2 Press **MAX SOUND** / \odot again to select an option.

Select preset equalizer

- 1 Press **EQ / AUDIO**.
↳ Current Equalizer setting is displayed.
- 2 Press **EQ / AUDIO** again to select a preset EQ setting:
 - **[OPTIMAL]** (optimal)
 - **[FLAT]** (flat)
 - **[POP]** (pop)
 - **[USER]** (user)
 - **[TECHNO]** (techno)
 - **[ROCK]** (rock)
 - **[CLASSIC]** (classic)
 - **[JAZZ]** (jazz)

Switch music listening zone

Philips' innovative Zone technology enables driver or passengers to enjoy music with the best speaker balance and experience more vivid spacial effects as the artist is intended to create. You can switch the music listening zone from driver to passengers for the best speaker sound settings in car.

- 1 Press and hold **ZONE**.
↳ The current setting is displayed.
- 2 Press **▲ / ▼** to select a setting:
 - **[ALL]**
 - **[FRONT LEFT]** (Front left)
 - **[FRONT RIGHT]** (Front right)
 - **[FRONT]**

Turn on/off full sound

- 1 Press and hold **🔊**.
↳ The current setting displays:
 - **[FULL ON]** : the full sound function is on.
 - **[FULL OFF]** : the full sound function is off.

- 2 Press **🔊** again to select an option.

Other sound settings

You can also adjust the preset **EQ / AUDIO** settings.

- 1 Press **EQ / AUDIO** for 3 seconds.
- 2 Press **▲** or **▼** repeatedly to select the item to be adjusted:
 - **[SUBWOOFER ON/OFF]** : Rotate **🔊** to turn on or off the subwoofer.
 - **[SUBWOOFER]** range: 0 to 12.
 - **[SUBWOOFER LPF]** (Subwoofer low pass filter) range: 80, 120, 160.
 - **[BALANCE]** range: 12L to 12R. (L=left speaker, R=right speaker)
 - **[FADER]** range: 12R to 12F. (R=rear speaker, F=front speaker)
 - **[BASS]** range: -7 to +7.
 - **[BASS CFQ]** (bass center frequency) range: 60, 80, 100, 200.
 - **[MIDDLE]** range: -7 to +7.
 - **[MIDDLE CFQ]** (middle center frequency) range: 0.5k, 1.0k, 1.5k, 2.5k.
 - **[TREBLE]** range: -7 to +7.
 - **[TREBLE CFQ]** (treble center frequency) range: 10.0k, 12.5k, 15.0k, 17.5k.
 - **[RESUME]** : Resume the preset EQ value to factory default value.
- 3 Rotate **🔊** to select a value.

8 Adjust system settings

Turn beep sound on/off

Each time you press a button, the unit beeps. You can turn the beep sound on/off.

- 1 Press and hold **MENU**.
- 2 Press **▲** or **▼** repeatedly until **[BEEP]** is displayed.
- 3 Rotate **⊙** to select a setting:
 - **[BEEP ON]**: turn on the beep sound.
 - **[BEEP OFF]**: turn off the beep sound.

Select blackout setting

You can set the screen to turn off automatically, after the unit is idle for 10 or 20 seconds.

- 1 Press and hold **MENU**.
- 2 Press **▲** or **▼** repeatedly until **[BLACK OUT]** is displayed.
- 3 Rotate **⊙** to select a setting:
 - **[BLK OUT 10 S]**: turn off the screen automatically 10 seconds after last operation.
 - **[BLK OUT 20 S]**: turn off the screen automatically 20 seconds after last operation.
 - **[BLK OUT OFF]**: never turn off the screen.

Turn demo mode on/off

- 1 Press and hold **MENU**.
- 2 Press **▲** or **▼** repeatedly until **[DEMO]** is displayed.

↳ The screen shows current demo mode setting.

- 3 Rotate **⊙** to select a setting:
 - **[DEMO ON]**: turn on the demo mode. When the unit is idle for more than 120 seconds, all functions are displayed.
 - **[DEMO OFF]**: turn off the demo mode.

Dimmer

- 1 Press and hold **MENU**.
- 2 Press **▲** or **▼** repeatedly until **[DIMMER]** is displayed.
- 3 Rotate **⊙** to select a setting:
 - **[DIMM HIGH]** (dimmer high)
 - **[DIMM LOW]** (dimmer low)

Dance

You can turn on or off the spectrum on the LCD display.

- 1 Press and hold **MENU**.
- 2 Press **▲** or **▼** repeatedly until **[DANCE]** is displayed.
- 3 Rotate **⊙** to select a setting:
 - **[DANCE ON]**: turn the spectrum on.
 - **[DANCE OFF]**: turn the spectrum off.

LCD Color

You can select your desired LCD color on this car audio.

- 1 Press and hold **MENU**.
- 2 Press **▲** or **▼** repeatedly until **[LCD COLOR]** is displayed.
- 3 Press **⊙**.

- 4 Rotate \odot to select a setting:
- [DEFAULT] (default setting)
 - [COLOR SCAN] (color scan)
 - [WHITE] (white)
 - [GREEN 1] (green 1)
 - [GREEN 2] (green 2)
 - [GREEN 3] (green 3)
 - [AMBER] (amber)
 - [PINK 1] (pink 1)
 - [PINK 2] (pink 2)
 - [PURPLE 1] (purple 1)
 - [PURPLE 2] (purple 2)
 - [BLUE 1] (blue 1)
 - [BLUE 2] (blue 2)
 - [USER COLOR] (user color)

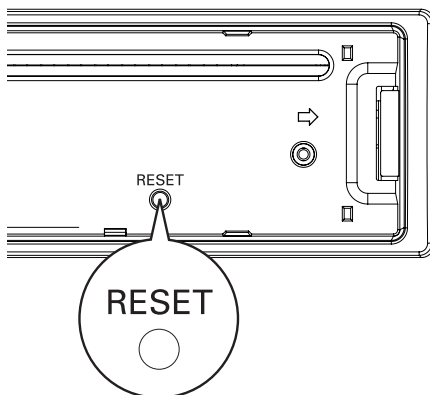

Audiobook

In iPod/iPhone mode, you can set the audiobook playback speed on this car audio.

- 1 Press and hold **MENU**.
- 2 Press \blacktriangle or \blacktriangledown repeatedly until [AUDIOBOOK] is displayed.
- 3 Rotate \odot to select a setting:
 - [FAST]
 - [SLOW]
 - [NORMAL]

Reset

You can reset the unit to its default setting.

- 1 Detach the front panel. (see 'Detach the front panel' on page 26)
- 2 Press the reset button by using a ball-point pen or a similar tool.
 - ↳ Preset adjustments such as preset channels and sound adjustments are erased.

9 Additional information

Detach the front panel

You can detach the front panel to deter theft.

- 1 Press  to release the panel.
- 2 Push the left side of the panel rightward.

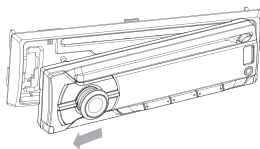
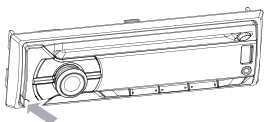

- 3 Pull the panel towards you to disengage it from the chassis.
- 4 Store the panel in the supplied carrying case to protect it from dirt or damage.

Replace fuse

If the fuse is damaged,

- 1 Check the electric connection.
- 2 Buy a fuse that matches the voltage of the damaged fuse.
- 3 Replace the fuse.

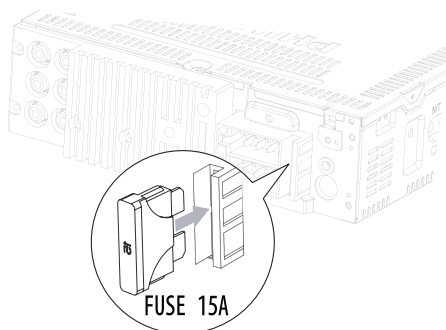

Note

- If the new fuse gets damaged again, there may be an internal malfunction. Consult your Philips dealer.

Remove the unit

You can remove the unit from the dashboard.

- 1 Detach the front panel.
- 2 Pull out the unit by using the disassembly tools.

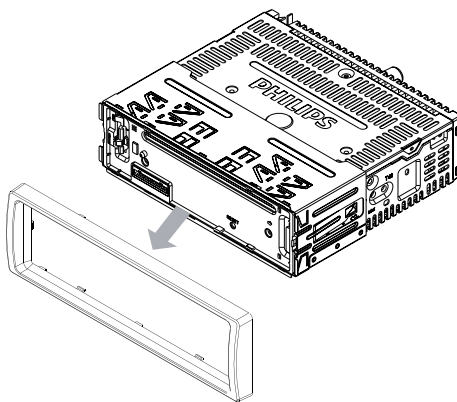

10 Product information

Note

- Product information is subject to change without prior notice.

Power supply	12 V DC (11 V - 16 V), negative ground
Fuse	15 A
Suitable speaker impedance	4 - 8 Ω
Maximum power output	50 W \times 4
Continuous power output	22 W \times 4 RMS (4 Ω 10% T.H.D.)
Pre-Amp output voltage	2.5V
Aux-in level	500 mV
Dimensions (W \times H \times D)	181.5 \times 52 \times 191.4 mm
Weight	1.32 kg

Radio

Frequency range - FM	65.0 - 74.0 MHz and 87.5 - 108.0 MHz (100 kHz per step in auto search and 50 kHz per step in manual search)
Frequency range - AM(MW)	522 - 1620 kHz (9 kHz) 530 - 1710 kHz (10 kHz)
Usable sensitivity - FM	8 μ V
Usable sensitivity - AM(MW) (S/N = 20 dB)	30 μ V

Bluetooth

Output power	0 dBm (Class 2)
Frequency band	2.4000 GHz - 2.4835 GHz ISM Band
Range	3 meters (free space)
Standard	Bluetooth 2.0 specification

Compatible USB devices:

- USB flash memory (USB 2.0 or USB1.1)
- USB flash players (USB 2.0 or USB1.1)
- memory cards (SD / SDHC)

Supported formats:

- USB or memory file format: FAT16, FAT32
- MP3 bit rate (data rate): 32-320 Kbps and variable bit rate
- WMA V4, V7, V8, V9 (L1, L2)
- ISO9660, Joliet

- Supported sampling frequencies: 2 kHz, 44.1 kHz, 48 kHz
- Supported Bit-rates: 2~256 (kbps), variable bit rates
- Directory nesting up to a maximum of 8 levels
- Number of albums/folders: CD maximum 99, USB or memory maximum 99
- Number of tracks/titles/files: CD maximum 999 (depending on number of album), USB or memory maximum 999
- ID3 tag v2.0 or later

Unsupported formats:

- Empty albums: an empty album is an album that does not contain MP3/WMA files, and is not be shown in the display.
- Unsupported file formats are skipped. For example, Word documents (.doc) or MP3 files with extension .dlf are ignored and not played.
- AAC, WAV, PCM audio files
- DRM protected WMA files (.wav, .m4a, .m4p, .mp4, .aac)
- WMA files in Lossless format

11 Troubleshooting



Caution

- Never remove the casing of this apparatus.

To keep the warranty valid, never try to repair the system yourself.

If you encounter problems when using this apparatus, check the following points before requesting service. If the problem remains unsolved, go to the Philips web site (www.philips.com/support). When you contact Philips, ensure that your apparatus is nearby and the model number and serial number are available.

No power or no sound.

- Car engine is not on. Turn the car engine on.
- Cable is not correctly connected. Check connections.
- Fuse is burnt. Replace fuse.
- Volume is too low. Adjust volume.
- If the above solutions cannot help, press the RESET button.
- Ensure that the track played is of a compatible format.

Noise in broadcasts.

- Signals are too weak. Select other stations with stronger signals.
- Check the connection of the car antenna.
- Change broadcast from Stereo to mono.

Cannot play disc

- Ensure that the disc label is inserted with the printed side facing up.
- Wipe the disc with fibre cleaning cloth from the centre to the edge in a straight line.
- This disc may be defective. Play another disc.
- Ensure that the CD is a finalised CD/CD-R/CD-RW.

- Ensure that the CD is not encoded with copyright protection technologies.

The CD skips tracks

- Ensure that the CD is not damaged or dirty.
- Ensure that random mode is deactivated.

Disc cannot be ejected

- Press and hold ▲.

Preset stations lost.

- Battery cable is not correctly connected. Connect the battery cable to the terminal that is always live.

Display show ERR-12

- USB data error. Check the USB device.

The paired mobile phone connects and disconnects constantly.

- The Bluetooth reception is poor. Move the mobile phone closer to the car audio system or remove any obstacle between the mobile phone and the system.
- Some mobile phones may connect and disconnect constantly when you make or end calls. This does not indicate any malfunction of the system.
- For some mobile phones, the Bluetooth connection may be deactivated automatically as a power-saving feature. This does not indicate any malfunction of the system.

About Bluetooth device

Cannot pair the Bluetooth enabled device with the car audio system.

- The device does not support the profiles required for the system.
- The Bluetooth function of the device is not enabled. Refer to the user manual of the device for how to enable the function.

The audio quality is poor after connection with a Bluetooth-enabled device.

- The microphone is not correctly positioned. Adjust the position of the microphone. For example, stick the microphone onto the dashboard where close to the driver.
- The Bluetooth reception is poor. Move the device closer to the car audio system or remove any obstacle between the device and the system.

Music playback is unavailable on the system even after successful Bluetooth connection.

The device cannot be used with the system to play music.

12 Glossary

M

MP3

A file format with a sound data compression system. MP3 is the abbreviation of Motion Picture Experts Group 1 (or MPEG-1) Audio Layer 3. With the MP3 format, one CD-R or CD-RW can contain about 10 times more data than a regular CD.

S

SD

Secure Digital. A type of memory card with a flash memory.

SDHC

Secure Digital High Capacity (SDHC) is a type of flash memory card based on the SDA 2.00 specification. The SDA 2.00 specification enables SD cards to reach higher capacities from 4GB to 32GB, and growing.

W

WMA (Windows Media Audio)

An audio format owned by Microsoft, is a part of Microsoft Windows Media technology. Includes Microsoft Digital Rights Management tools, Windows Media Video encoding technology, and Windows Media Audio encoding technology.

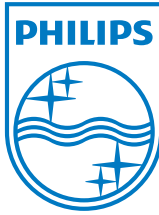

Specifications are subject to change without notice
© 2013 Koninklijke Philips Electronics N.V.
All rights reserved.

CEM5200_51_UM_V1.0

