

Register your product and get support at
www.philips.com/welcome

User manual



PHILIPS

1

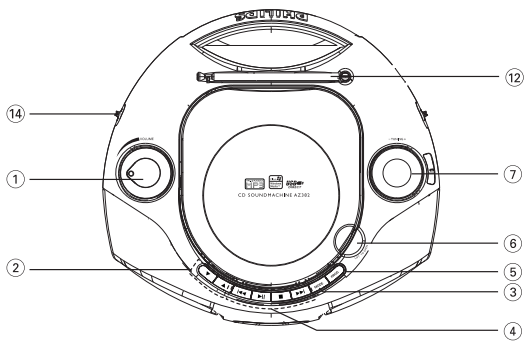
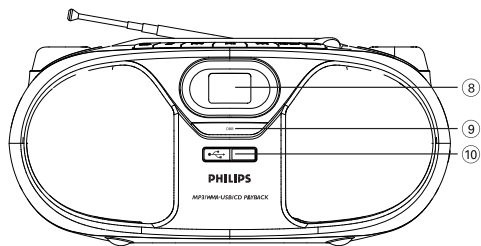

2

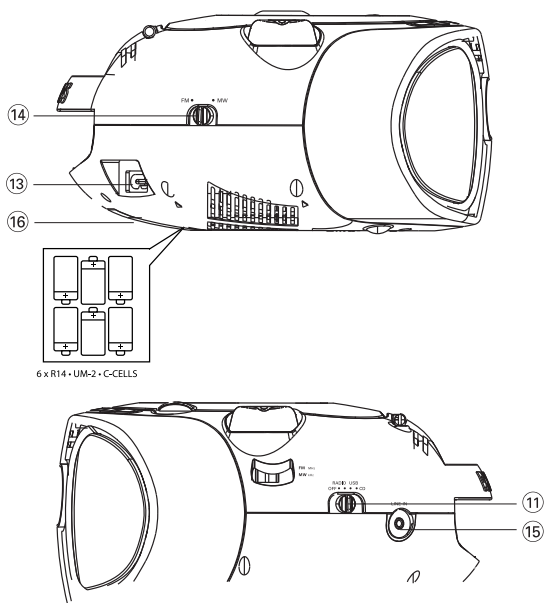

3



7



4



8



5

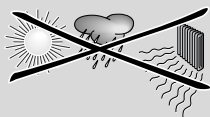

6

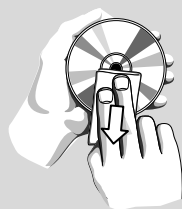

Congratulations on your purchase and welcome to Philips!

To fully benefit from the support that Philips offers, register your product at www.philips.com/welcome.

Supplied Accessories

– AC power cord

Top/front panels (See 1)

- ① **VOLUME** – adjusts volume level.
- ② **▼▲** – **For MP3-CD/USB only:** select albums.
- ③ **MODE** – selects different play modes:
e.g. REPEAT or SHUFFLE (random order).
- ④ **▶ II** – starts or pause CD/USB playback
▶ II ◀ – selects the next/previous track
– searches forwards/backwards (press and hold the button) within the current track
■ – stops disc/USB playback;
– erases a program
- ⑤ **PROG** – programs tracks and reviews the program
- ⑥ **LIFT TO OPEN** – opens/closes the CD door.
- ⑦ **TUNING** – tunes to radio stations
- ⑧ **Display** – shows the CD/USB functions
- ⑨ **DBB** – turns the bass enhancement on/off.
- ⑩ **USB port** – connects an external USB mass storage device.

Back panel (See 1 and 2)

- ⑪ **Source selector: CD, USB, RADIO, OFF**
– selects CD, USB or radio source of sound
– power off switch
- ⑫ **Telescopic antenna** – improves FM reception.
- ⑬ **AC MAINS~** – inlet for power cord.
- ⑭ **Band selector** – selects wavebands: MW or FM.
- ⑮ **LINE-IN** – inlet for external audio source.

Bottom panel

- ⑯ **Battery door** – Press on the arrow and push to insert 6 x 1.5V **R-14/ UM-2/ C-cells**.

CAUTION

- Visible and invisible laser radiation. If the cover is open, do not look at the beam.
- High voltage! Do not open. You run the risk of getting an electric shock. The machine does not contain any user-serviceable parts.
- Modification of the product could result in hazardous radiation of EMC or other unsafe operation.

Power Supply

Whenever convenient, use the power supply cord if you want to conserve battery life.

Make sure you remove the plug from the set and wall outlet before inserting batteries.

Batteries (not included)

- 1 Open the battery door and insert 6 batteries, type **R-14**, **UM-2** or **C-cells**, (preferably alkaline) with the correct polarity as indicated by the "+" and "-" symbols inside the compartment.
- 2 Replace the battery door, making sure the batteries are firmly and correctly in place. The set is now ready to operate.

Batteries contain chemical substances, so they should be disposed of properly.

- Incorrect use of batteries can cause electrolyte leakage and will corrode the compartment or cause the batteries to burst:
- Do not mix battery types: e.g. alkaline with carbon zinc. Only use batteries of the same type for the set.
- When inserting new batteries, do not try to mix old batteries with the new ones.
- Remove the batteries if the set is not to be used for a long time.

Using AC power

WARNING: Always check you have completely switched off the set, before you change or disconnect power supply.

- 1 Check if the power voltage, **as shown on the type plate located on the bottom of the set**, corresponds to your local power supply. If it does not, consult your dealer or service center.
 - 2 Connect the power cord to the **AC MAINS~** inlet and the wall socket. The set is now connected and ready for use.
 - 3 To switch the set off completely, withdraw the power cord from the wall socket.
 - 4 Install the unit near the AC outlet and where the AC power plug can be easily reached.
- Disconnect the power cord from the wall socket to protect your set during heavy

thunderstorms. Children could seriously injure themselves as the free end of the cable may still be live if only the connector is removed from the MAINS socket at the back of the unit.

The type plate is located on the bottom of the set.

Helpful hints:

- To avoid unnecessary energy consumption, always adjust the **Source selector** to **OFF** after using the set.

General operation

Switching on and off and selecting the function

- 1 To select your sound source, adjust the **Source selector** to: **CD**, **USB** or **RADIO**.
- 2 To switch off the set, adjust the **Source selector** to **OFF** position.
- 3 To switch to **LINE IN** mode, connect an external audio source to the **LINE-IN** inlet.

Helpful hints:

- The set switches to **LINE IN** mode automatically when an external audio source is connected, no matter the set is in **CD**, **USB** or **RADIO** mode.
- The **LINE-IN** inlet is not for earphones.

Adjusting volume and sound

Adjust the sound with the **VOLUME** and **DBB** controls.

Radio reception

- 1 Adjust the **Source selector** to **RADIO**.
- 2 Adjust the band selector to select your desired waveband: **MW** or **FM**.
- 3 Turn **TUNING** to tune to a station.

Helpful hints:

To improve radio reception

- For **FM**, extend, incline and turn the telescopic antenna for best reception. Reduce its length if the signal is too strong.
- For **MW**, the set uses a built-in antenna. Direct this antenna for best reception by turning the whole set.

About MP3

The music compression technology MP3 (MPEG1 Audio Layer 3) significantly reduce the digital data of an audio CD while maintaining CD quality sound.

- **Getting MP3 files:** you can either download legal music files from the internet to your computer hard disc, or create such files by converting audio CD files in your computer through appropriate encoder software. (128kbps bit rate or higher is recommended for MP3 files.)
- **Creating an MP3 CD:** burn the music files from your computer hard disc on a CDR or CDRW using your CD burner.

Helpful Hints:

- Make sure that the file names of the MP3 files end with **.mp3** .
- Total number of music files and albums: around 400 (with a typical file name length of 20 characters)
- The length of file names affects the number of tracks for playback. With shorter file names, more files can be burned on a disc.

Playing a disc

- This CD player plays Audio Discs including CD-Recordables (CD-R), CD-Rewritables (CD-RW) and MP3/WMA CD.
- CD-ROM, CD-I, CDV, VCD, DVD or computer CDs are not possible for playback.

IMPORTANT!

- CDs encoded with **copyright protection technologies** by some record companies may be unplayable by this product.
- DRM-protected WMA disc is not support.

1 Adjust the **Source selector** to **CD**.

- 2 Open the CD door, and insert a CD with the printed side facing up, then press the CD door gently to close.

→ Display shows ---, and later the total number of tracks. (See [3])

- 3 Press ►|| to start playback.

- 4 To pause playback, press ►||.

→ Display: ► flashes. (See [4])

- 5 To resume, press ►|| again.

- 6 To stop playback, press ■.

Helpful hints:

CD play will also stop when:

- you open the CD door;
- you select **USB**, **RADIO** or **OFF**;
- the CD has reached the end.

MP3/WMA/CD Player

Selecting a different track

- Press **◀▶** once or repeatedly until the desired track number appears in the display.
For MP3/WMA-CD: First press **▼▲** once or more to select your album.
- In the pause/stop position, press **▶||** to start playback.

Finding a passage within a track

- 1 During playback, press and hold **◀▶** or **▶▶**.
→ The CD is played at high speed and with reduced volume.
- 2 When you recognize the passage you want, release **◀▶** or **▶▶** to resume normal playback.

Helpful hints:

- When your searching reaches the end of the last track, the CD goes to stop mode.

Programming track numbers

You may store up to 20 tracks in the desired sequence. If you like, store any track more than once.

- 1 In the stop position, press **PROG** to activate programming.
→ Display: **PROG** and **P 0 1** flash. (See [5](#))
- 2 Press **◀▶** or **▶▶** to select your desired track number.
For MP3/WMA-CD: first press **▼▲** once or more to select your album.
- 3 Press **PROG** to store the desired track number.
→ Display: **PROG** and **P 0 2** flash for you to program the next track.
- 4 Repeat steps **2** to **3** to select and store all desired tracks in this way.
→ If you attempt to store more than 20 tracks, no track can be selected and the display shows **- - -**.
- 5 To play your program, press **▶||**.

Helpful hints :

- When playback of your program comes to the stop position, your set will return to normal playback. To re-enter program mode, press **PROG** in the stop position.

Reviewing the program

In the stop position, press **PROG** repeatedly to see your stored tracks.

Erasing a program

You can erase the contents of the memory by:

- in the stop position, press **PROG** to enter program mode, and then press **■**.
- during program play, press **■** twice.
- selecting **USB**, **RADIO** or **OFF**;
- opening the CD door;

Different play modes: REPEAT and SHUFFLE (See [6](#), [7](#))

You can select and change the various play modes before or during playback, and combine REPEAT modes with **PROG** (PROGRAM).

↻ – plays the current track continuously.

For MP3:

- ↻ **ALB** – plays all tracks of current album repeatedly.
- ↻ **ALL** – plays all tracks/program repeatedly.
- ∞ – plays all tracks in random order.

- 1 To select play mode, press **MODE** once or more.
→ The display shows the related icon.
→ When you select SHUFFLE mode, play starts automatically.
- 2 Press **▶||** to start playback if in the stop/pause position.
- 3 To return to normal playback, press **MODE** repeatedly until the modes are no longer displayed.
– You can also press **■** to cancel your play mode.

USB Connection

Using USB connectivity

- AZ382 is fitted with a USB port in the front panel, offering a plug and play feature which allows you to play, from your AZ382, digital music and spoken contents stored on a USB mass storage device.
- Using a USB mass storage device, you can also enjoy all the features offered by AZ382 which are explained and instructed in the sections of disc operation.

Compatible USB mass storage devices

With the AZ382, you can use

- USB flash memory (USB 2.0 or USB 1.1)
- USB flash player (USB 2.0 or USB 1.1)
- USB device which requires driver installation under Windows XP is not supported.

Note:

In some USB flash players (or memory devices), the stored contents are recorded using copyright protection technology. Such protected contents will be unplayable on any other devices (such as AZ382 device).

Supported formats:

- USB or memory file format FAT12, FAT16, FAT32 (sector size: 512 - 65,536 bytes)
- MP3 bit rate (data rate): 32-320 kbps and variable bit rate
- WMA v9 or earlier
- Directory nesting up to a maximum of 8 levels
- Number of albums: maximum 40
- Number of tracks: maximum 464
- ID3 tag v2.0 or later
- File name in Unicode UTF8 (maximum length: 128 bytes)

The system will not play or support the following:

- Empty albums: an empty album is an album that does not contain MP3/WMA files, and will not be shown in the display.
- Non-supported file formats are skipped. This means that e.g.: Word documents .doc

or MP3 files with extension .dlf are ignored and will not be played.

- AAC, WAV, PCM, NTFS audio files
- DRM protected WMA files
- WMA files in Lossless format

Playing a USB mass storage device

- 1 Make sure that your AZ382 is being powered by AC mains or specified batteries.
- 2 Adjust the **source selector to USB**.
→ Display shows - - - (see [2]).
- 3 Plug a compatible USB mass storage device to AZ382's USB port marked . If needed, use a suitable USB cable to connect between the device and AZ382's USB port.
→ The device will automatically power on.
- If the device is not powered on, turn on the power manually, then re-connect it.
→ AZ382's display shows - - - and then the total number of playable audio files (Max. displayed track number is 464) stored on the device.
- 4 Press **▶||** on your AZ382 to start play.
→ AZ382's display will show the current track number.

Helpful hints:

- Up to 464 playable audio files stored on a USB mass storage device can be played on AZ382.
- Up to 40 playable albums stored on a USB mass storage device can be selected and displayed on AZ382.
- Make sure that file names of MP3 files end with .mp3, and the file names of WMA files end with .wma.
- For DRM protected WMA files, use Windows Media Player 10 (or later) for conversion. Visit www.microsoft.com for details about Windows Media Player and WM DRM (Windows Media Digital Rights Management).
- For USB device playing, if the display shows "OL", it means that the USB device is electrically overloading AZ382. You need to change a USB device.

Maintenance & Safety (See 8)

CD player and CD handling

- If the CD player cannot read CDs correctly, use a cleaning CD to clean the lens before taking the set to repair.
- The lens of the CD player should never be touched!
- Sudden changes in the surrounding temperature can cause condensation on the lens of your CD player. Playing a CD is then not possible. Do not attempt to clean the lens but leave the set in a warm environment until the moisture evaporates.
- Always close the CD door to avoid dust on the lens.
- To clean the CD, wipe in a straight line from the center towards the edge using a soft, lint-free cloth. Do not use cleaning agents as they may damage the disc.
- Never write on a CD or attach any stickers to it.
- Do not expose the set, batteries, CDs to humidity, rain, sand or excessive heat caused by heating equipment or direct sunlight.
- The apparatus shall not be exposed to dripping or splashing.
- Adequate ventilation with a minimum gap of 15cm (6 inches) between the ventilation holes and surrounding surfaces is necessary to prevent heat build-up.
- Do not cover the ventilation openings with items such as newspapers, table-cloths, curtains, etc.
- No objects filled with liquids, such as vases, shall be placed on the apparatus.
- No naked flame sources, such as lighted candles, should be placed on the apparatus.
- The mechanical parts of the set contain self-lubricating bearings and must not be oiled or lubricated.
- To clean the set, use a dry cloth. Do not use any cleaning agents containing alcohol, ammonia, benzene or abrasives as these may harm the housing.

Safety information

- Place the set on a flat, hard and stable surface so that the system does not tilt.
- Where the MAINS plug or an appliance coupler is used as the disconnect device, the disconnect device shall remain readily operable.

Troubleshooting

If a fault occurs, first check the points listed below before taking the set for repair.

If you are unable to remedy a problem by following these hints, consult your dealer or service centre.

WARNING:

Do not open the set as there is a risk of electric shock. Under no circumstances should you try to repair the set yourself, as this will invalidate the guarantee.

Problem

- Possible cause
- Remedy

No sound /power

- Volume not adjusted
- **Adjust the VOLUME**
- Power cord not securely connected
- **Connect the AC power cord properly**
- Batteries dead/ incorrectly inserted
- **Insert (fresh) batteries correctly**
- CD contains non-audio files
- Press **⏮**, **⏭** once or more to skip to a CD audio track, instead of the data file.

Display does not function properly / No reaction to operation of any of the controls

- Electrostatic discharge
- **Switch off and unplug the set. Reconnect after a few seconds**

---,Er or no indication

- No CD inserted
- **Insert a CD**
- CD badly scratched or dirty
- **Replace/ clean CD, see Maintenance**
- Laser lens steamed up
- **Wait until lens has cleared**
- CD-R/CD-RW is blank or not finalized
- **Use a finalized CD-R/CD-RW or suitable CD Audio disc only**

Note:

Make sure the CD is not encoded with copyright protection technologies, as some do not conform to the Compact Disc standard.

The CD skips tracks

- CD damaged or dirty
- **Replace or clean CD**
- Program/shuffle is active
- **Quit program/shuffle mode**

Note: A CD badly scratch or dirty may result in improper operation.

Sound skips during MP3 playback

- MP3 file made at compression level exceeding 320kbps
- **Use a lower compression level to record CD tracks into MP3 format**
- Disc damaged or dirty
- **Replace or clean disc**

The USB device doesn't play on my AZ382

- It is not set in the USB mode.
- **Adjust the source selector to USB.**
- The device is not securely connected to AZ382's USB port.
- **Re-connect the device, and make sure that the device is powered on.**
- The device is not supported by AZ382, or the audio file format stored on the device is not supported by AZ382.
- **Use a compatible device/ playable audio file format.**

Environmental information

All unnecessary packaging material has been omitted. The packaging can be easily separated into three materials: cardboard, polystyrene and plastic.

Your set consists of materials which can be recycled if disassembled by a specialized company. Please observe the local regulations regarding the disposal of packaging, dead batteries and old equipment.

Specifications

Power Consumption.....15W

Dimensions (w x h x d)..... 261 x 121 x 245 (mm)

Weight..... 1.63 kg

Meet Philips at the Internet
<http://www.philips.com>



AZ382



Printed in China

PDCC2009