

Always there to help you

Register your product and get support at
www.philips.com/support



CE135BT



User manual

PHILIPS

Contents

1	Safety	2	12	Product information	17
2	Your car audio system	3	13	Troubleshooting	18
	Introduction	3		General	18
	What's in the box	3		About the Bluetooth device	18
	Overview of the system	4			
3	Install the car audio system	6	14	Notice	19
	Connect wires	7		Disposal of your old product	19
	Mount into the dashboard	8		Trademark notice	19
	Attach the front panel	9		Copyright	19
4	Get started	10			
	For the first time use	10			
	Set the clock	10			
	Select a source	10			
5	Listen to radio	10			
	Select a tuner region	10			
	Select a tuner sensitivity	10			
	Search for a radio station	11			
	Store radio stations in memory	11			
6	Play from a storage device	12			
7	Use Bluetooth devices	13			
	Connect a device	13			
	Play audio from a Bluetooth device	14			
	Make a call	14			
8	Listen to an external device	15			
9	Charge your USB device	15			
10	Adjust sound	16			
11	Reset the system	16			

1 Safety

Read and understand all instructions before you use this device. If damage is caused by failure to follow instructions, the warranty does not apply.

- Modification of the product could result in hazardous radiation of EMC or other unsafe operation.
- The device is designed for negative ground (earth) 12 V DC operation only.
- To ensure safe driving, adjust the volume to a safe and comfortable level.
- Improper fuses can cause damage or fire. When you need to change the fuse, consult a professional.
- Use only the supplied mounting hardware for a safe and secure installation.
- To avoid short circuits, do not expose the device to rain or water.
- The device shall not be exposed to dripping or splashing.
- Do not place any sources of danger on the device (e.g. liquid filled objects, lighted candles).
- Never insert objects into the ventilation slots or other openings on the device.
- Clean the device with soft, damp cloth. Never use substances such as alcohol, chemicals or household cleaners on the device.

2 Your car audio system

Introduction

With this system, you can:

- enjoy audio from USB storage devices, SD/SDHC card, and other external players, and Bluetooth device.
- listen to radio stations.

You can enrich sound output with these sound effects:

- Dynamic bass boost (DBB)
- Digital sound control (DSC)

Playable media:

- USB storage device
 - Compatibility: USB 2.0, USB 1.1
 - Class support: MSC (Mass Storage Class)
 - Maximum capacity: 32 GB
- SD/SDHC card
 - Maximum capacity: 32 GB
- Files
 - File system: FAT16, FAT32
 - Maximum number of folders: 99
 - Maximum number of tracks/files: 999
 - Maximum level of directory: 8
 - .mp3 files
 - Sampling frequencies: 32 kHz, 44.1 kHz, 48 kHz
 - Bitrates: 8-320 kbps and variable bitrates
 - ID3 tag V2.0 or later
 - **Unsupported files:** AAC, WAV, and PCM files

What's in the box



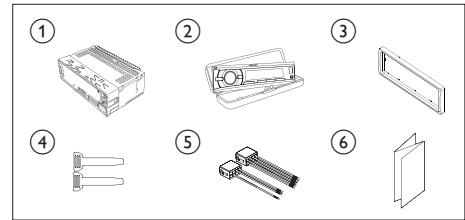

Check and identify the contents of the package:



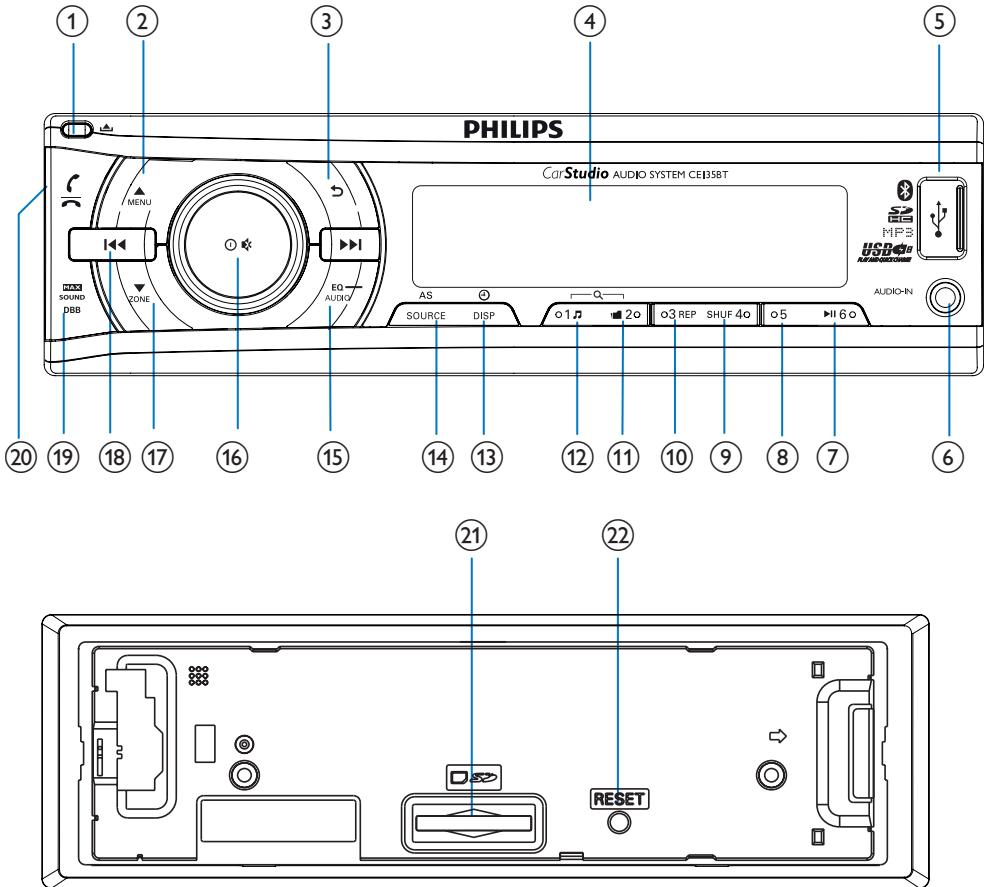







- ① Main unit (with a sleeve)
- ② Carrying case (with front panel included)
- ③ Trim plate
- ④ Disassembly tool X 2
- ⑤ ISO male connector X 2
- ⑥ User manual

Overview of the system



- ① 
 - Unlock the front panel.
- ② 
 - For .mp3 tracks, press to select the previous folder.
 - Press and hold to access the system menu.
 - Press to select a tuner band.
- ③ 
 - Return to the previous menu.
- ④ LCD screen
- ⑤ 
 - Connect to a USB storage device.
- ⑥ AUDIO IN
 - Connect to the audio output socket (usually the headphone socket) of an external device.
- ⑦ 
 - Start, pause, or resume the play of tracks.

- In radio mode, press to select the preset radio station of No. 6.
 - In radio mode, press and hold to store the current radio station at channel No. 6.
- ⑧ 5
- In radio mode, press to select the preset radio station of No. 5.
 - In radio mode, press and hold to store the current radio station at channel No. 5.
- ⑨ SHUF 4
- In radio mode, press to select the preset radio station of No. 4.
 - In radio mode, press and hold to store the current radio station at channel No. 4.
 - For .mp3 tracks, press repeatedly to select a play mode: play all tracks randomly ([SHU ALL]), play tracks in the current folder randomly ([SHU FLD]), or play all tracks in the storage device in sequence ([SHU OFF]).
- ⑩ 3 REP
- In radio mode, press to select the preset radio station of No. 3.
 - In radio mode, press and hold to store the current radio station at channel No. 3.
 - For .mp3 tracks, press repeatedly to select a repeat mode: repeat the current track ([REP ONE]), repeat all tracks in the current folder ([RPT FLD]), or repeat all tracks in the storage device ([RPT ALL]).
- ⑪  2
- In radio mode, press to select the preset radio station of No. 2.
 - In radio mode, press and hold to store the current radio station at channel No. 2.
 - For .mp3 tracks, press to access the folder list.
- ⑫  1
- In radio mode, press to select the preset radio station of No. 1.
 - In radio mode, press and hold to store the current radio station at channel No. 1.
 - For .mp3 tracks, press to access the track list.
- ⑬  /DSP
- Press repeatedly to display available information about the current track.
 - Press and hold to display the set clock.
- ⑭ AS/SOURCE
- Press repeatedly to select a source.
 - In radio mode, press and hold to activate the automatic search of radio stations.
- ⑮  EQ
AUDIO
- Press repeatedly to select a preset sound equalizer.
 - Press and hold to activate the setup of bass, treble, balance, and fader.
- ⑯  
- Press to turn on the system.
 - Press and hold to turn off the system.
 - Press to mute the speakers or release them from mute status.
 - Press to confirm an option.
 - Rotate to switch between menu options.
 - Rotate to adjust the volume level.
- ⑰  ZONE
- For .mp3 tracks, press to select the next folder.
 - Press and hold to activate the selection of listening zones.
 - Press to select a tuner band.
- ⑱ 
- Tune to a radio station.
 - Press to skip to the previous/next track.
 - Press and hold to rewind a track or search fast forward.

19 

- Press to enable or disable the **MAX Sound** effect.
- Press and hold to enable or disable the **DBB** (dynamic bass boost) sound effect.

20 

- Press to hang up a call.
- Press and hold to reject an incoming call.

21 

- Insert an SD/SDHC card.

22 **RESET**

- Press to reset the system to factory default settings.

3 Install the car audio system

Caution

- Use the controls only as stated in this user manual.

Always follow the instructions in this chapter in sequence.

These instructions are for a typical installation. However, if your car has different requirements, make the adjustment accordingly. If you have any question regarding installation kits, consult your local retailer.

Note

- This system is designed for negative ground (earth) 12V DC operation only.
- Always install this system in the car dashboard. Other locations can be dangerous as the rear of the system heats up during use.
- To avoid short-circuit: before you connect, make sure that the ignition is off.
- Make sure that you connect the yellow and red power supply leads after all other leads are connected.
- Make sure that all loose leads are insulated with electrical tape.
- Make sure that the leads do not get caught under screws iron parts that will move (e.g. seat rail).
- Make sure that all ground (earth) leads are run to a common ground (earth) point.
- Use only the supplied mounting hardware for a safe and secure installation.
- Improper fuses can cause damage or fire. When you need to change the fuse, consult a professional.
- When you connect other devices to this system, make sure that the rating of the car circuit is higher than the total fuse value of all the connected devices.
- Never connect speaker wires to the metal body or chassis of the car.
- Never connect speaker wires with stripes to one another.

Connect wires

Note

- Make sure that all loose leads are insulated with electrical tape.
- Consult a professional to connect wires as instructed below.

- 1 Check the car's wiring carefully and connect them to the the ISO male connectors.

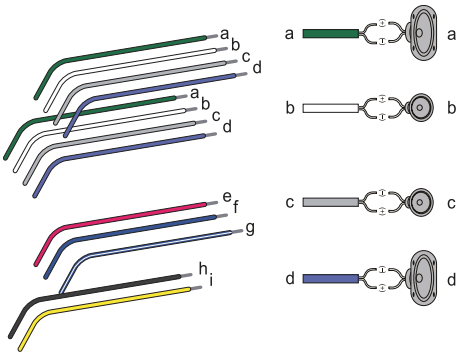

	ISO male connectors	Connect to
a	Green strip, black-edged green strip	Rear left speaker
b	White strip, black-edged white strip	Front left speaker
c	Gray strip, black-edged gray strip	Front right speaker
d	Purple strip, black-edged purple strip	Rear right speaker
e	Red strip	Ignition key +12V DC when ON/ ACC
f	Blue strip	Motor/electric antenna relay control lead
g	White-edged blue strip	Amplifier relay control lead
h	Black strip	Ground

i Yellow strip To the +12V car battery which is energized at all times

- 2 Connect the antenna and amplifier as illustrated, if applicable.

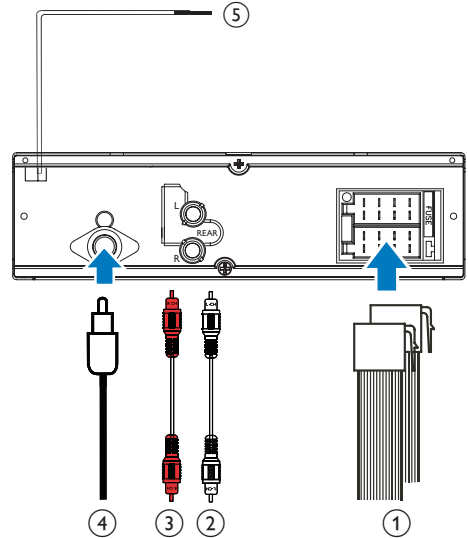

	Sockets on rear panel	External sockets or connectors
1	For ISO male connectors	As indicated above
2	REAR L	Rear left speaker
3	REAR R	Rear right speaker
4	ANTENNA	Antenna
5	purple strip	OE remote control module

Tip

- The pin arrangement for the ISO connectors depends on the type of your vehicle. To avoid damage to the unit, connect properly.

Mount into the dashboard

- If the car does not have an on-board drive or navigation computer, disconnect the negative terminal of the car battery.
- If the car battery is not disconnected, to avoid short-circuit, make sure that the bare wires do not touch each other.

1 Make sure that the car dashboard opening is within these measurements:

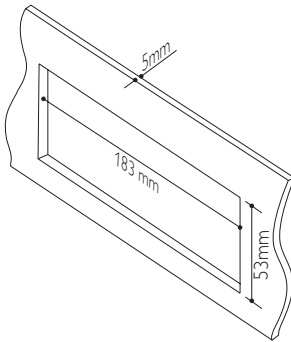

2 Remove the mounting sleeve with the supplied disassembly tools.

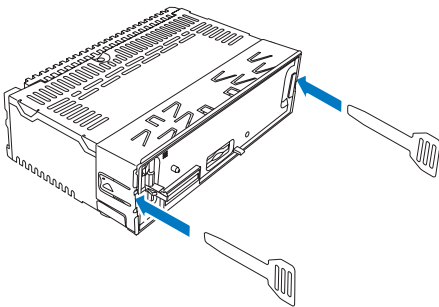

3 Install the sleeve into the dashboard and bend the tabs outward to fix the sleeve.

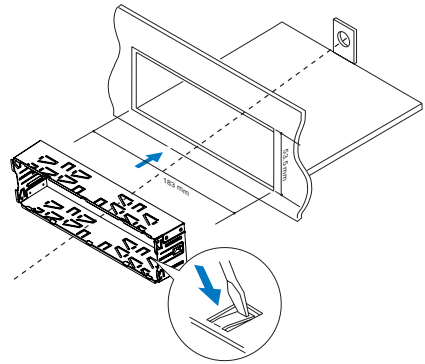

4 Slide the unit into the dashboard until you hear a "click".

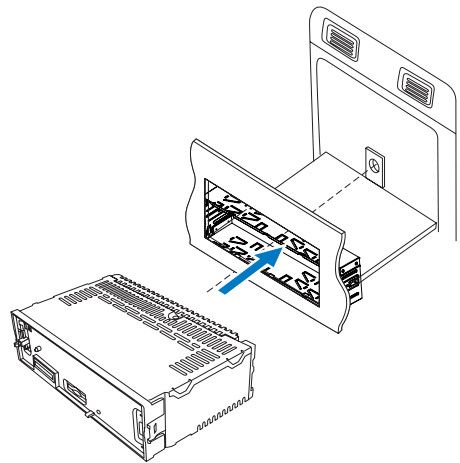

5 Attach the trim plate.

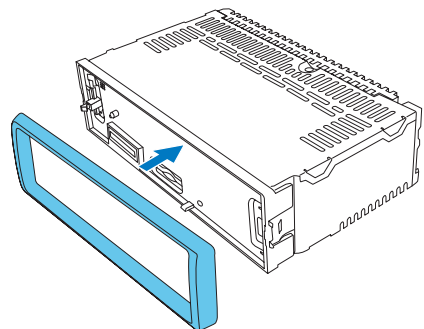

- 6 Reconnect the negative terminal of the car battery.

Attach the front panel

- 1 Insert the notch on the front panel to the chassis on the main unit.

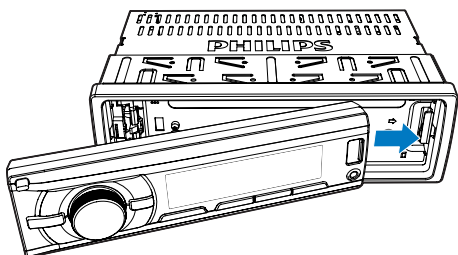

- 2 Press the left end of the front panel inwards until it is securely locked with a "click".

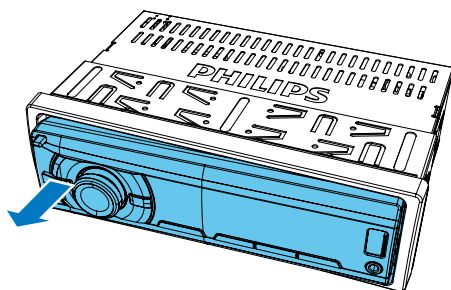
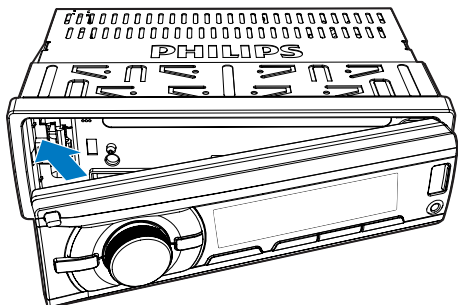

Detach the front panel

Note

- Before you insert an SD/SDHC card or reset the system, detach the front panel.
- Before you detach the front panel, make sure that the system is turned off.

- 1 Press  to release the front panel.
- 2 Pull the front panel outwards to remove it.

4 Get started

For the first time use

Press **⊙** to turn on the system.

- ↳ **[PHILIPS]** is displayed and the device turns to radio mode automatically.

Set the clock

- 1 Press and hold **▲** to access the system menu.
- 2 Press **▲** / **▼** repeatedly until **[CLK]** is displayed with time digits blinking.
- 3 Rotate **⊙** anti-clockwise to set the hour.
- 4 Rotate **⊙** clockwise to set the minute.

Select a source

Press **AS/SOURCE** repeatedly to select a source.

- **[RADIO]**: Listen to FM/AM radio.
- **AUDIO IN**: Listen to the audio input through the **AUDIO IN** socket.
- **[USB]**: When a USB storage device is connected and recognized, you can select this source to play audio files that are stored on it.
- **[SD/SDHC]**: When an SD/SDHC card is inserted and recognized, you can select this source to play audio files that are stored on it.

5 Listen to radio

Select a tuner region

You can select a radio region that matches your location.

- 1 Press and hold **▲** to access the system menu.
- 2 Press **▲** / **▼** repeatedly until one of the following options is displayed.
 - **[AREA EUROPE]** (Western Europe)
 - **[AREA ASIA]** (Asia Pacific)
 - **[AREA MID--EAST]** (Middle East)
 - **[AREA AUST]** (Australia)
 - **[AREA RUSSIA]** (Russia)
 - **[AREA USA]** (United States)
 - **[AREA LATIN]** (Latin America)
- 3 Rotate **⊙** to select a region.

Select a tuner sensitivity

To search for radio stations with strong signals only or more radio stations, you can change the tuner sensitivity.

- 1 Press and hold **▲** to access the system menu.
- 2 Press **▲** / **▼** repeatedly until **[LOC ON]** or **[LOC OFF]** is displayed.
- 3 Rotate **⊙** to select a setting.
 - **[LOC ON]**: Search for radio stations with strong signals only.
 - **[LOC OFF]**: Search for radio stations with strong and weak signals.

Search for a radio station

Search for a radio station automatically

Press **◀◀** or **▶▶** to search for the previous or next radio station with strong signals.

Search for a radio station manually

- 1 Press and hold **◀◀** or **▶▶** until **[M]** blinks.
- 2 Press **◀◀** or **▶▶** repeatedly until the target frequency is displayed.

Store radio stations in memory



Note

- You can store a maximum of six stations in each band.

Store radio stations automatically

- 1 Switch the source to **[RADIO]**.
- 2 Press **▲** or **▼** repeatedly to select a band.
- 3 Press and hold **AS/SOURCE** until **[STORE---**] is displayed.
 - ↳ After the search is complete, the first stored radio station is broadcast automatically.
 - To select a stored radio station, press **1**, **2**, **3**, **4**, **5**, or **6**.

Store radio stations manually

- 1 Press **▲** or **▼** repeatedly to select a tuner band.
- 2 Tune to the radio station that you want to store.
- 3 Press and hold **1**, **2**, **3**, **4**, **5**, or **6** to store the radio station at the selected channel.
 - To select a stored radio station, press **1**, **2**, **3**, **4**, **5**, or **6**.

6 Play from a storage device

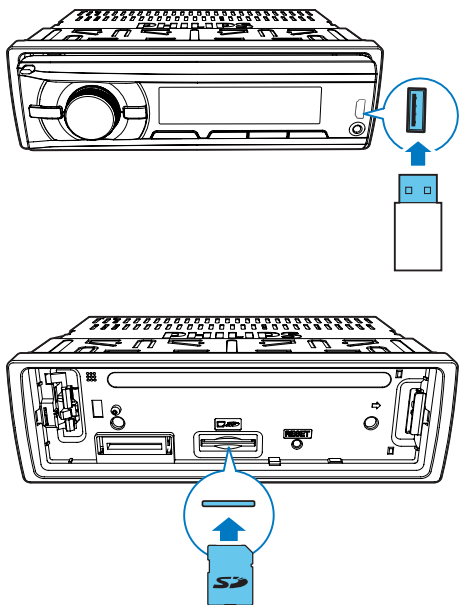

- 1 Connect a compatible USB storage device or SD/SDHC card.
 - For an SD/SDHC card, detach the front panel first, insert the card into the card slot, and then attach the front panel.
- 2 Switch the source to **[USB]** or **[SD/SDHC]**.
- 3 If the play does not start, press **▶||6**.

Button	Function
▲ / ▼ MENU / ZONE	Press repeatedly to select a folder.
▶ 6	Pause or resume play.
◀◀ / ▶▶	Press to play the previous or next track.
◀◀ / ▶▶	Press and hold to rewind a track or search forward fast.
⊕ / DISP	Press repeatedly to display available information about the current track.
3 REP	Press repeatedly to select a repeat mode: <ul style="list-style-type: none"> • [REP ONE]: repeat the current track, • [RPT FLD]: repeat all tracks in the current folder; or • [RPT ALL]: repeat all tracks in the storage device.
SHUF 4	Press repeatedly to select a play mode: <ul style="list-style-type: none"> • [SHU ALL]: play all tracks randomly, • [SHU FLD]: play tracks in the current folder randomly, or • [SHU OFF]: play all tracks in the storage device in sequence.

7 Use Bluetooth devices

With this car audio system, you can listen to audio from a player or make a call through Bluetooth.

Connect a device

Note

- Gibson Innovations does not guarantee the compatibility with all Bluetooth devices.
- Before pairing a device with this system, read its user manual for Bluetooth compatibility.
- Make sure that Bluetooth function is enabled on your device, and your device is set as visible to all other Bluetooth devices.
- At one time, you can connect only one Bluetooth device to this system.
- The operational range between this system and a Bluetooth device is approximately 3 meters (9 feet).
- Any obstacle between this system and a Bluetooth device can reduce the operational range.
- Keep away from any other electronic device that may cause interference.

On your device, follow the steps below.

- 1 Search for Bluetooth devices.
- 2 In the device list, select **CE135BT**.
- 3 Enter the default password "0000", and then confirm the password entry.
 - ↳ If the pairing succeeds, **[PAIRED]** is displayed on the LCD screen of this system.
- 4 Enable or permit the connection with CE135BT.
 - ↳ If the connection succeeds, **[CONNECTED]** scrolls and  is displayed on the LCD screen of this system.
 - ↳ If the connection fails, **[FAILED]** is displayed on the LCD screen of this system.

Disconnect a device

- 1 Press and hold **MENU** to access the system menu.
- 2 Press **▲ / ▼** repeatedly until **[DIS-CON]** is displayed.
- 3 Press **⊙** :
 - ↳ **[WAIT]** is displayed with -, --, and --- blinking alternately until **[DISCONNECTED]** scrolls.

Tip

- You can also complete the disconnection on your device.

Reconnect a device

Some Bluetooth devices support the automatic reconnection with a paired Bluetooth device. If your device does not support automatic reconnection, reconnect it with this system manually.

- 1 Press and hold **MENU** to access the system menu.
- 2 Press **▲ / ▼** repeatedly until **[RE-CON]** is displayed.
- 3 Press **⊙** :
 - ↳ **[WAIT]** is displayed with -, --, and --- blinking alternately until **[CONNECTED]** scrolls or **[FAILED]** appears.
 - ↳ If **[CONNECTED]** scrolls, this system is reconnected to the last connected device.

Tip

- You can also complete the reconnection on your device.

Play audio from a Bluetooth device

If the connected Bluetooth device supports Advanced Audio Distribution Profile (A2DP), you can listen to tracks that are stored on the device through the system. If the device also supports Audio Video Remote Control Profile (AVRCP) profile, you can control play on the system.

- 1 Play a track on the connected device.
- 2 Press **SOURCE** repeatedly to switch the source to **[BT AUDIO]**.
 - ↳ Play starts automatically.
 - To pause or resume play, press **▶||◀**.
 - To skip to the previous or next track, press **◀◀ / ▶▶**.

Note

- If the connected device does not support the AVRCP profile, control play on the connected device.

Make a call

Note

- Keep the Bluetooth connection active between the system and your mobile phone.

Call a number

On your mobile phone, call a number:

- ↳ **[CALLING]** is displayed.

Pick up an incoming call

When the system receives an incoming call, the phone number or **[PHONE IN]** is displayed. Press **☎** to answer the call.

Reject an incoming call

Press and hold  until **[END]** is displayed.

End a call

To end an on-going call, press .

8 Listen to an external device

You can use the system to amplify the audio input from an external device, for example, MP3 player:

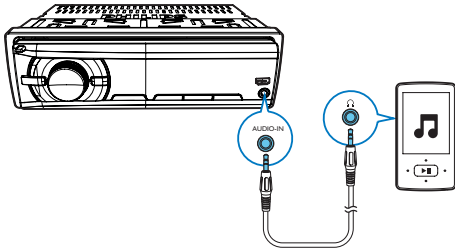

- 1 Switch the source to **AUDIO IN**.
- 2 Connect an audio in cable to
 - the **AUDIO IN** socket on the system, and
 - the audio output socket (usually the headphone socket) on the external device.
- 3 Play the external device.

9 Charge your USB device

You can charge your USB device, for example, smart phone, with this product.







Note

- The output voltage through the USB socket is 5 V with output current 1 A.

Connect your USB device to this product with USB cable. Once the USB device is connected and recognized, it begins to charge automatically.

10 Adjust sound

The following operations are applicable to all supported media.

Button	Function
	Rotate to increase or decrease the volume level.
	Press to mute the speakers or release them from mute status.
	Press to enable or disable the MAX Sound effect.
	Press and hold to enable or disable the Dynamic Bass Boost (DBB) effect.
	Press repeatedly to select a sound equalizer.
	<ol style="list-style-type: none">1 Press and hold to activate the setup of customized sound equalizer.2 Press repeatedly to select an option: [BAS] (bass), [TRE] (treble), [BAL] (balance), or [FAD] (fader).3 Rotate  to adjust the setting.

11 Reset the system

If the system works abnormally, reset the system to factory default settings.

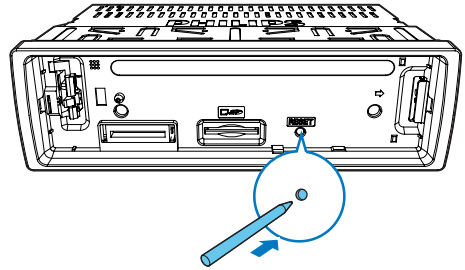

- 1 Detach the front panel.
- 2 Press the **RESET** button with the tip of a ball-point pen or toothpick.
↳ All settings are reset to factory default.

12 Product information

Note

- Product information is subject to change without prior notice.

General

Power supply	12 V DC (11 V - 16 V), negative ground
Fuse	15 A
Suitable speaker impedance	4 - 8 Ω
Maximum power output	50 W \times 4
Continuous power output	22 W \times 4 RMS (4 Ω 10% T.H.D.)
Pre-Amp output voltage	2.5 V
Aux-in level	\geq 500 mV
Dimensions (W \times H \times D)	188 \times 58 \times 110 mm
Weight - main unit	0.63 kg

Radio

Frequency range - FM	87.5 - 108.0 MHz (100kHz per step in auto search and 50kHz per step in manual search)
Usable sensitivity - FM (S/N = 20 dB)	8 μ V
Frequency range - AM(MW)	522 - 1620 KHz (9 kHz) 530 - 1710 kHz (10 kHz)
Usable sensitivity - AM(MW) (S/N = 20 dB)	30 μ V

Bluetooth

Output power	Class 2
Frequency band	2.4000 GHz - 2.4835 GHz ISM Band
Range	3 meters(free space)
Standard	Bluetooth 2.0 specification

13 Troubleshooting



Warning

- Never remove the casing of this product.

To keep the warranty valid, never try to repair the product yourself.

If you encounter problems when using this device, check the following points before requesting service. If the problem remains unsolved, go to the Philips Web page (www.philips.com/support). When you contact the Consumer Care, make sure that the product is nearby and the model number and serial number are available.

General

No power or no sound

- The power supply from car battery is cut off, or the car battery runs out of energy. Power the system with car battery.
- Car engine is not on. Turn the car engine on.
- Cable is not correctly connected. Check connections.
- The fuse is burnt. Replace the fuse.
- Volume is too low. Adjust volume.
- If the above solutions cannot help, press the **RESET** button.
- Make sure that the current track is in a compatible format.

Noise during broadcast

- Signals are too weak. Select other stations with stronger signals.
- Check the connection of the car antenna.
- Change the broadcast setting from stereo to mono.

Presets are erased.

- Battery cable is not correctly connected. Connect the battery cable to the terminal that is always live.

Display shows ERR-12.

- Data error. Check the USB storage device or SD/SDHC card.

About the Bluetooth device

Music playback is unavailable on the system even after successful Bluetooth connection.

- The device cannot be used with the system to play music.

The audio quality is poor after connection with a Bluetooth-enabled device.

- The Bluetooth reception is poor. Move the device closer to the system or remove any obstacle between the device and the system.

Cannot connect with the system.

- The device does not support the profiles required for the system.
- The Bluetooth function of the device is not enabled. Refer to the user manual of the device to find out how to enable the function.
- The system is not in the pairing mode.
- The system is already connected with another Bluetooth-enabled device. Disconnect that device or all other connected devices and then try again.

The paired mobile phone connects and disconnects constantly.

- The Bluetooth reception is poor. Move the mobile phone closer to the system or remove any obstacle between the mobile phone and the system.
- Some mobile phones may connect and disconnect constantly when you make or end calls. This does not indicate any malfunction of the system.
- For some mobile phones, the Bluetooth connection may be deactivated automatically as a power-saving feature. This does not indicate any malfunction of the system.

14 Notice

Any changes or modifications made to this device that are not expressly approved by Gibson Innovations may void the user's authority to operate the equipment.

Disposal of your old product



Your product is designed and manufactured with high quality materials and components, which can be recycled and reused.

Do not throw away the product with the normal household waste at the end of its life, but hand it in at an official collection point or recycling. By doing this, you help to preserve the environment.

Environmental information

All unnecessary packaging has been omitted. We have tried to make the packaging easy to separate into three materials: cardboard (box), polystyrene foam (buffer) and polyethylene (bags, protective foam sheet.)

Your system consists of materials which can be recycled and reused if disassembled by a specialized company. Please observe the local regulations regarding the disposal of packaging materials, exhausted batteries and old equipment.

Trademark notice

The Bluetooth® word mark and logos are registered trademarks owned by Bluetooth SIG, Inc. and any use of such marks by Gibson Innovations Limited is under license.

Other trademarks and trade names are those of their respective owners.

Copyright

2015 © Gibson Innovations Limited. All rights reserved.

Philips and the Philips' Shield Emblem are registered trademarks of Koninklijke Philips N.V. and are used by Gibson Innovations Limited under license from Koninklijke Philips N.V.' Specifications are subject to change without notice. Gibson reserves the right to change products at any time without being obliged to adjust earlier supplies accordingly.



Specifications are subject to change without notice.
2015 © Gibson Innovations Limited. All rights reserved.
Philips and the Philips' Shield Emblem are registered trademarks
of Koninklijke Philips N.V. and are used by Gibson Innovations
Limited under license from Koninklijke Philips N.V.

CE135BT_55/85_UM_Online_V2.0

