



Quick start guide

CD680/CD685

PHILIPS

What's in the box



Handset*

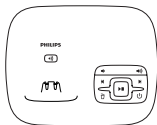

Base station (CD685)



Base station (CD680)



Charger*



Power adapter*

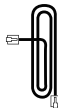

Line cord**

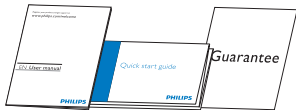

User manual
Quick start guide
Guarantee

Note

- * In multi-handset packs, there are additional handsets, chargers and power adapters.
- ** In some countries, you have to connect the line adapter to the line cord, then plug the line cord to the telephone socket.

Caution

- Use only the supplied batteries and power adapter.

1 Connect

Connect the base station

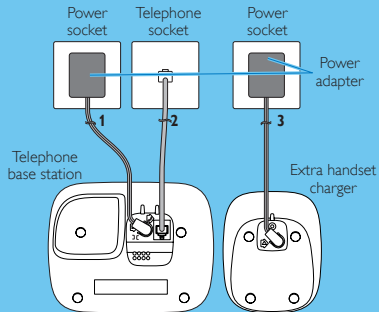

- 1 Connect each end of the power adapter to:
 - the DC input jack at the bottom of the base station;
 - the power socket on the wall.
- 2 Connect each end of the line cord to:
 - the telephone socket at the bottom of the base station;
 - the telephone socket on the wall.

For multi-handset version only:

- 3 Connect each end of the power adapter to:
 - the DC input jack at the bottom of the extra handset charger.
 - the power socket on the wall.

2

Get started

Configure your phone

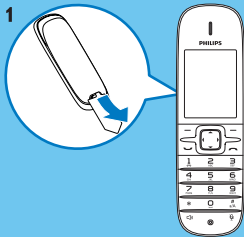

- 1 The batteries are pre-installed in the handset. Pull the battery tape off from the battery door before charging.
- 2 When using your phone for the first time, you see a welcome message (country dependent).
- 3 Please set the country and language if prompted.
- 4 Set the date and time.
 - If the time is in 12-hour format, press * key to select **[AM]** or **[PM]**.

Charge your phone

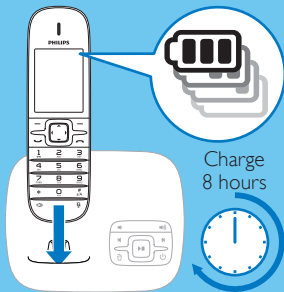

Place the handset on the base station to charge the handset. When the handset is placed correctly on the base station, you hear a docking sound.

↳ The handset starts charging.

Note Charge the batteries for 8 hours before first use.

Check the battery level



When the handset is off the base station/charger, the bars indicate the battery level (full, medium and low). When the handset is on the base station/charger, the bars flash until charging completes.





The empty battery icon flashes and you hear an alert tone.



The battery is low and needs recharging.

3 Enjoy

Call

- To make a call, press  and dial the phone number.
- To answer a call, press  when the phone rings.
- To end a call, press .

Adjust the earpiece volume

Press  or  to adjust the volume during a call.

Add a contact in the phonebook







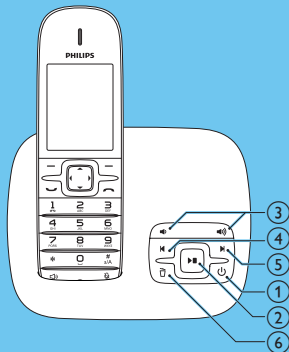

- 1 Press .
- 2 Select **[Option]** > **[Add new]**, then press **[OK]** to confirm.
- 3 Enter the name then press **[OK]** to confirm.
- 4 Enter the number; then press **[Save]** to confirm.

Record an announcement (for CD685 only)

- 1 Press **[Menu]**
- 2 Select  > **[Announcement]**, then press **[OK]** to confirm.
- 3 Select **[Answer only]** or **[Answer & rec.]**, then press **[OK]** to confirm.
- 4 Select **[Record new]**, then press **[OK]** to confirm.
- 5 Start recording close to the microphone after the beep.
- 6 Press **[OK]** to stop recording.
 - ↳ You can listen to the newly recorded announcement on the handset.

Listen to messages recorded on the answering machine (for CD685 only)



- ① Switch on/off the answering machine: Press .
- ② Start/Stop listening to the recorded messages: Press .
- ③ Adjust the volume: Press  / .
- ④ Skip backward:
When you listen to the messages, press  to listen to the message from the beginning.
During the first second of the current message, press  to listen to the previous message.
- ⑤ Skip forward: Press  to skip to the next message.
- ⑥ Delete the current message: Press .

Note For more information, see the Telephone answering machine section in the user manual.

Welcome to Philips

Register your product at www.philips.com/welcome

Need help?

User manual

Refer to the user manual that came with your new phone.

Online help

www.philips.com/support



Reproduction in whole or in part is prohibited without the written consent of the copyright owner. Trademarks are the property of Koninklijke Philips Electronics N.V. or their respective owners. © 2011 Koninklijke Philips Electronics N.V. All rights reserved.



CE 0168

QSG_CD680-685_EN_V2.1
WK11102