

A Connect Conexión Connexion

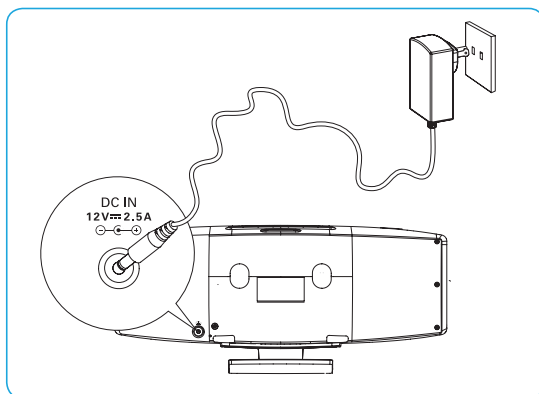

B Set clock Ajuste del reloj Réglage de l'horloge

EN Note:

You can set the clock in the standby mode only.

- 1 Press and hold **PROG/CLOCK SET** to enter the clock setting mode.
- 2 Press **◀▶▶▶** repeatedly to select 12 hour or 24 hour format.
- 3 Press **PROG/CLOCK SET** to confirm.
- 4 Press **◀▶▶▶** to set the hour.
- 5 Press **PROG/CLOCK SET** to confirm.
- 6 Press **◀▶▶▶** to set the minute.
- 7 Press **PROG/CLOCK SET** to confirm the clock setting.

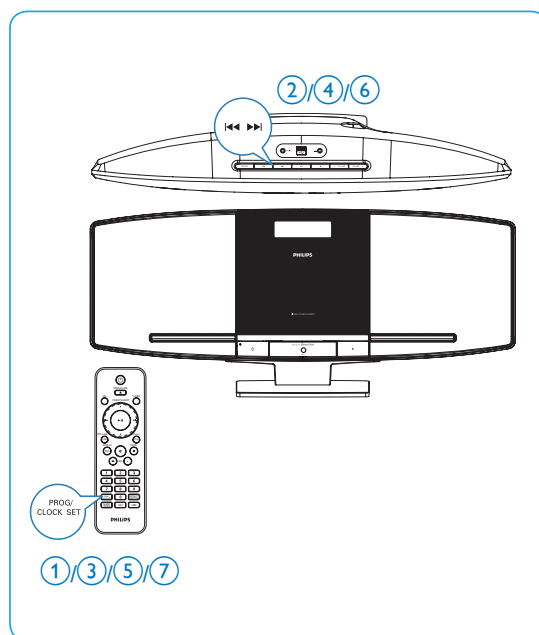

ES Nota:

Sólo se puede configurar el reloj en el modo de espera.

- 1 Mantenga pulsado **PROG/CLOCK SET** para acceder al modo de ajuste del reloj.
- 2 Pulse **◀▶▶▶** repetidamente para seleccionar el formato de 12 ó 24 horas.

- 3 Pulse **PROG/CLOCK SET** para confirmar.
- 4 Pulse **◀▶▶▶** para ajustar las horas.
- 5 Pulse **PROG/CLOCK SET** para confirmar.
- 6 Pulse **◀▶▶▶** para ajustar los minutos.
- 7 Pulse **PROG/CLOCK SET** para confirmar el ajuste del reloj.

FR

Remarque:

Vous pouvez régler l'horloge uniquement en mode veille.

- 1 Maintenez la touche **PROG/CLOCK SET** enfoncée pour accéder au mode de réglage de l'horloge.
- 2 Appuyez plusieurs fois sur **◀◀▶▶** pour sélectionner le format 12 heures ou 24 heures.
- 3 Appuyez sur **PROG/CLOCK SET** pour confirmer.

- 4 Appuyez sur **◀◀▶▶** pour régler l'heure.
- 5 Appuyez sur **PROG/CLOCK SET** pour confirmer.
- 6 Appuyez sur **◀◀▶▶** pour régler les minutes.
- 7 Appuyez sur **PROG/CLOCK SET** pour confirmer le réglage de l'horloge.

C

Play a disc

Reproducción de discos

Lectura d'un disque

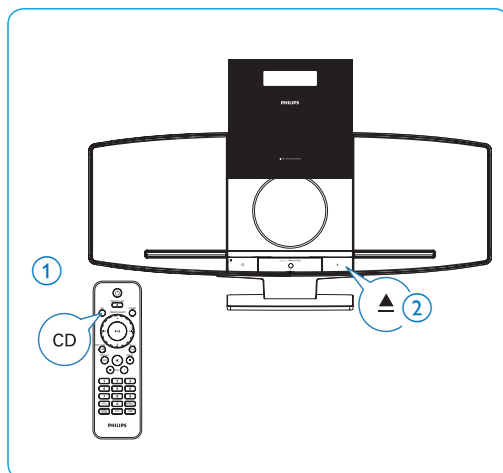

D

Listen to radio

Cómo escuchar la radio

Écoute de la radio

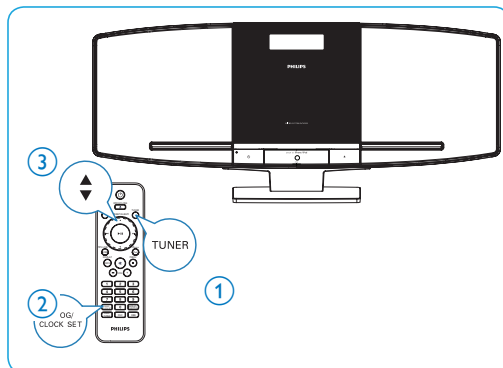

E

Play from USB

Reproducción desde un dispositivo USB

Lecture à partir d'un périphérique USB

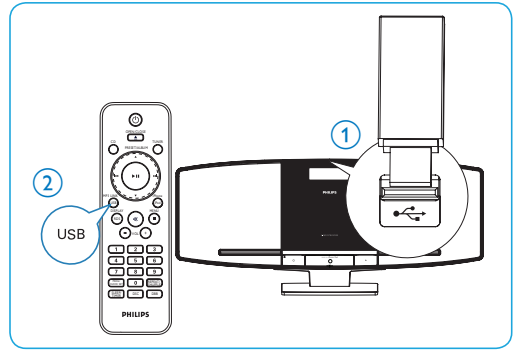

F

Play iPod/iPhone

Reproducción desde el iPod/iPhone

Lecture à partir d'un iPod/iPhone

