

Register your product and get support at
www.philips.com/welcome

CEM3000



EN Installation guide

PHILIPS

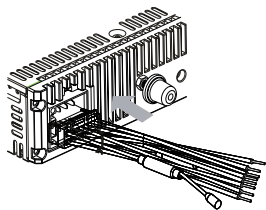
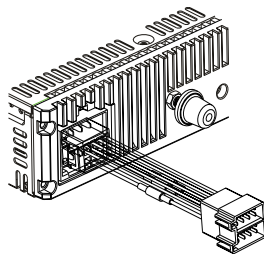
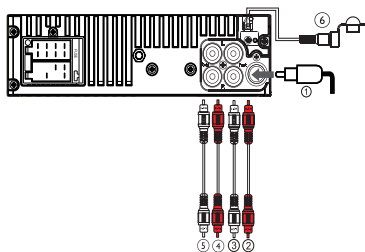
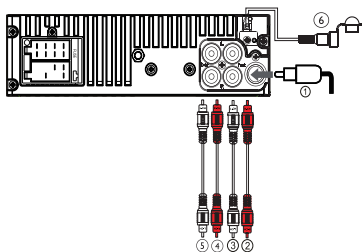
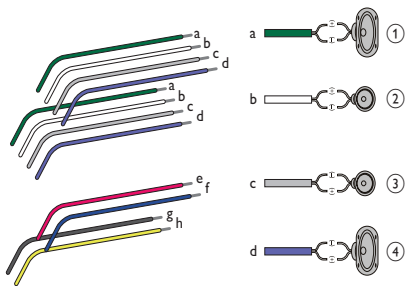
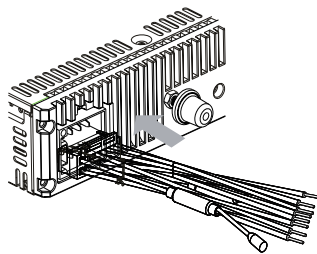
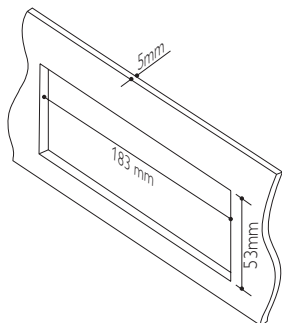
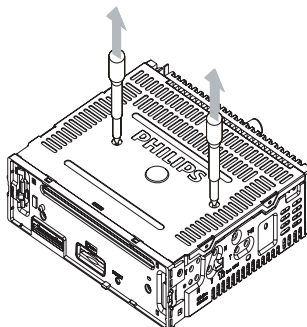
A**B****C****D****E****F****G****H**

I

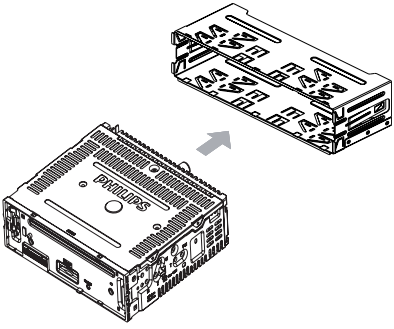

J

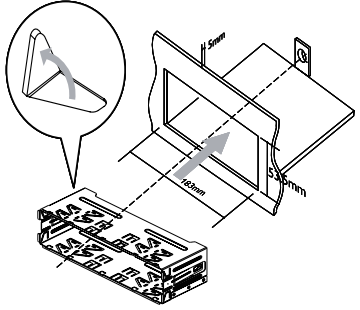

K

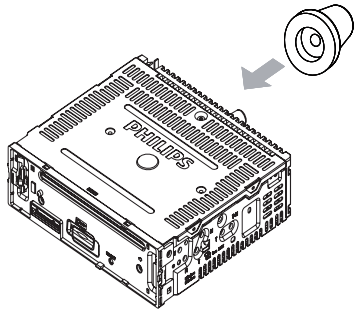

L

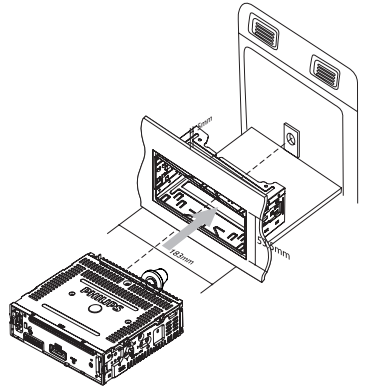

M

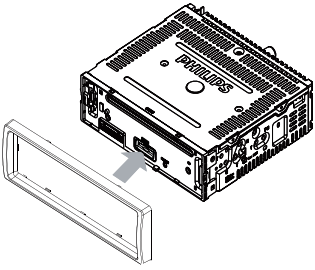

N

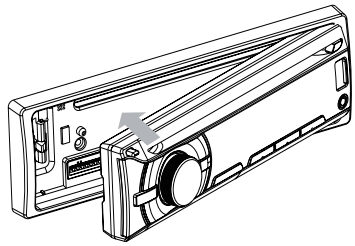

Installation guide

These instructions are for a typical installation. However, if your car has different requirements, make the corresponding adjustment. If you have any questions regarding installation kits, consult your Philips car audio dealer.

Caution

- This unit is designed for negative ground (earth) 12V DC operation only.
- Always install this unit in the car dashboard. Other locations can be dangerous as the rear of the unit heats up during use.
- To avoid short-circuit: before you connect, ensure that the ignition is off.
- Ensure that you connect the yellow and red power supply leads after all other leads are connected.
- Ensure that all loose leads are insulated with electrical tape.
- Ensure that the leads do not get caught under screws or in parts that will move (e.g. seat rail).
- Ensure that all ground (earth) leads are run to a common ground (earth) point.
- Use only the supplied mounting hardware for a safe and secure installation.
- Improper fuses can cause damage or fire. When you need to change the fuse, consult a professional.

Note on the power supply lead (yellow)

- When you connect other devices to this apparatus, ensure that the rating of the car circuit is higher than the total fuse value of all the connected devices.

Notes on speaker connection

- Never connect speaker wires to the metal body or chassis of the car.
- Never connect speaker wires with stripes to one another.

Connection: for cars with ISO connectors

Caution

- Ensure that all loose leads are insulated with electrical tape.

- 1 Pull out the ISO connectors from car dashboard and connect them to the bigger end of the supplied standard connector. **A**
- 2 Connect the other end of the supplied standard connector to the unit. **B**
- 3 Connect the antenna and amplifier as illustrated, if applicable. You can connect the car audio to the amplifier through RCA-TO-RCA cables (not supplied). **C**

	Connector	Connect to
1	ANTENNA	Antenna
2	FRONT LINE OUT R (Socket)	Front right speaker
3	FRONT LINE OUT L (Socket)	Front left speaker
4	REAR LINE OUT R (Socket)	Rear right speaker
5	REAR LINE OUT L (Socket)	Rear left speaker
6	SUBWOOFER	Subwoofer

Connection: for cars without ISO connectors

Caution

- Be sure to connect the black ground (earth) lead first.

- 1 Connect the antenna and amplifier as illustrated, if applicable. **D**

	Connector	Connect to
1	ANTENNA	Antenna
2	FRONT LINE OUT R (Socket)	Front right speaker
3	FRONT LINE OUT L (Socket)	Front left speaker
4	REAR LINE OUT R (Socket)	Rear right speaker
5	REAR LINE OUT L (Socket)	Rear left speaker
6	SUBWOOFER	Subwoofer

- 2 Cut off the bigger end of the supplied standard connector.

3 Check the car's wiring carefully and connect them to the supplied standard connector. **E**

1	Green/black strip	Left speaker (Rear)
2	White/black strip	Left speaker (Front)
3	Gray/black strip	Right speaker (Front)
4	Purple/black strip	Right speaker (Rear)
e	RED	Ignition key +12V DC when ON/ACC
f	BLUE	Motor/electric antenna relay control lead/Amplifier relay control lead
g	BLACK	Ground
h	YELLOW	To the +12V car battery which is energized at all times

4 Connect the supplied standard connector to the unit. **F**

Tip

- The pin arrangement for the ISO connectors depends on the type of vehicle you drive. Be sure to make proper connections to prevent damage to the unit.

Mount into the dashboard

1 If the car does not have an on-board drive or navigation computer, disconnect the negative terminal of the car battery.

- If you disconnect the car battery in a car that has an on-board drive or navigation computer, the computer may lose its memory.
- If the car battery is not disconnected, to avoid short-circuit, ensure that the bare wires do not touch each other.

2 Ensure that car dashboard opening is within these measurements: **G**

3 Remove the two screws on the top of the unit. **H**

4 Remove the mounting sleeve with the supplied disassembly tools. **I**

5 Install the sleeve into the dashboard and bend the tabs outward to fix the sleeve. **J**

Note

- If the unit is not fixed by sleeve but by the supplied screws, skip this step.
- 6** Place the supplied rubber cushion over the end of the mounting bolt. **K**
- 7** Slide the unit into the dashboard until you hear a click sound. **L**
- 8** Reconnect the negative terminal of the car battery.

Attach the front panel

1 Attach the trim plate. **M**

2 Insert the right side of the panel in the chassis until it is correctly engaged.

3 Press the left side of the panel until the mechanism locks it into place. **N**



© 2010 Koninklijke Philips Electronics N.V.

All rights reserved.

CEM3000/x78_IG_V1.0

