

Register your product and get support at
www.philips.com/welcome

SPP1028A



User manual

PHILIPS

1 Important safety instructions

This manual contains important information about the Philips power surge protectors. Read it carefully before you start the installation and setup.



Warning

- Do not operate your surge protector in the rain or near wet areas.
- Do not operate your surge protector if liquid of any kind is spilled onto or inside the unit.
- Do not disassemble or repair.
- Do not expose your surge protector to direct sunlight or place it near wall heaters, space heaters, or enclosed space prone to temperature increase.
- The Philips surge protector requires a properly grounded outlet for safety and to protect the connected equipment. If you are not sure whether your home's electrical wiring has proper grounding, consult a qualified electrician.



Caution

- Risk of electrical shock! Not for use outdoors or in other wet or damp areas, with aquariums, in hazardous environments requiring failsafe performance (such as nuclear facilities or aircraft), or for medical or life support equipment.

residential installation. This equipment generates, uses and can radiate radio frequency energy and, if not installed and used in accordance with the instruction manual, may cause harmful interference to radio communications.

However, there is no guarantee that interference will not occur in a particular installation. If this equipment does cause harmful interference to radio or television reception, which can be determined by turning the equipment off and on, the user is encouraged to try to correct the interference by one or more of the following measures:

- Relocate the receiving antenna.
- Increase the separation between equipment and receiver.
- Connect the equipment into an outlet on a circuit different from that to which the receiver is connected.
- Consult the dealer or an experienced radio/TV technician for help.

Recycling



Your product is designed and manufactured with high quality materials and components, which can be recycled and reused.

Never dispose of your product with other household waste. Please inform yourself about the local rules on the separate collection of electrical and electronic products. The correct disposal of your old product helps prevent potentially negative consequences on the environment and human health.

The packaging of this product is intended to be recycled. Contact your local authorities for information about how to recycle the packaging.

Notice

iPod and iPhone are trademarks of Apple Inc., registered in the U.S. and other countries. iPad is a trademark of Apple Inc.

Notice for USA

This equipment has been tested and found to comply with the limits for a Class B digital device, pursuant to part 15 of the FCC Rules. These limits are designed to provide reasonable protection against harmful interference in a

2 Your surge protector

Congratulations on your purchase and welcome to Philips!

To fully benefit from the support that Philips offers, register your product at www.philips.com/welcome.

Overview

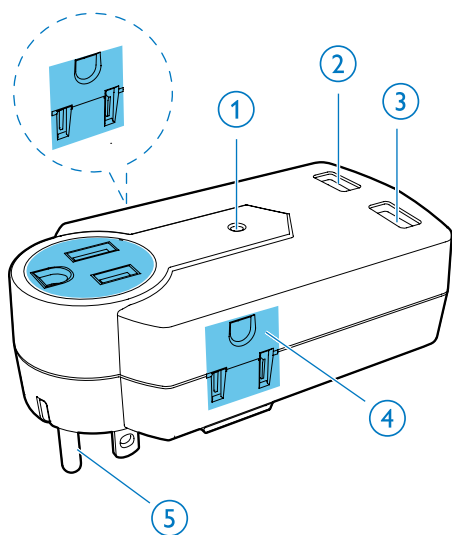

- ① [PROTECTED] indicator light
- ② USB charging port B
- ③ USB charging port A
- ④ AC outlet
- ⑤ AC Plug

3 Get started

This surge protector is designed to guard the connected equipment against electrical damage. Philips offers an entire line of surge protectors to safeguard your home electronics and computer systems.

Connect the surge protector

- 1 Lift up the flat pins of AC plug till you hear a click.

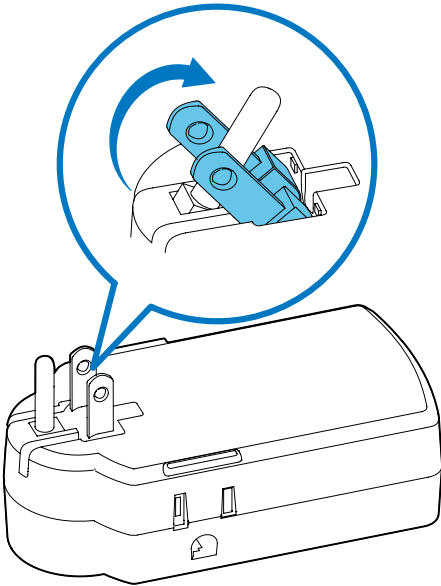

- 2 Plug the surge protector into a properly grounded outlet.
↳ The [PROTECTED] indicator light is on.
- 3 Plug the power cord of devices into the AC outlets of surge protector.
↳ The connected devices are protected by the surge protector.

! Caution

- If the [PROTECTED] indicator light is off when you plug the surge protector, the unit should be replaced.
- Do not use any extension cords, adapters, other grounded wire or electrical connections with your surge protector. Doing so will void all Philips warranties.

Disconnect the surge protector

- 1 Unplug the surge protector from grounded outlet.
- 2 Put down the round pin to hide the AC plug.

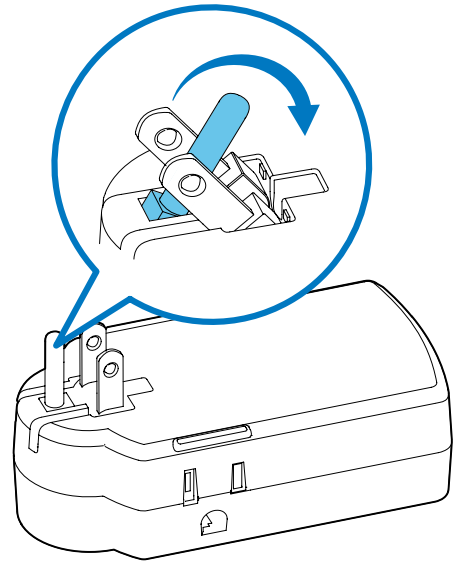

4 Power/Charge your devices

You can also use this surge protector to power or charge iPod, iPhone, iPad, smart phones, tablets and other USB devices.

Power/Charge from AC outlet

There are three AC outlets in this surge protector:

- 1 Plug a proper charging adaptor (not included) into the AC outlet.
- 2 Connect your device to output of the charging adaptor.
 - ↳ The connected device is powered or charged.

Charge from USB port



Note

- Devices are protected from power surges only when plugged into the AC outlets. USB ports are for charging only.

There are two USB charging ports in this surge protector: USB charging port **A** is for charging iPod, iPhone or iPad. USB charging port **B** is for charging smart phones, tablets, or other USB devices.

Connect your device to the USB charging port with a USB cable (not included).

- ↳ The connected device is charged.



Tip

- If your device is not charged, unplug the USB cable and try another USB charging port.
- In case some devices are only charged with its original adaptor, you can charge from AC outlet.

5 Limited warranty

Philips, Inc. ("Philips") provides one or both of the following warranties (Surge Protector Limited Warranty and Connected Equipment Limited Warranty) to the original consumer of surge protectors sold under the Philips brand names.

These warranties apply only to natural purchasers of surge protectors for personal, family or household use, not to commercial, institutional or industrial purchasers. These warranties are valid only in US and Canada.

Except as provided in Connected Equipment Limited Warranty (if applicable), in no event shall Philips be liable for any direct, indirect, incidental, special, consequential or multiple damage arising out of the use of the use of Philips surge protector.

Limited One-Year Warranty

Philips warrants that this product shall be free from defects in material, workmanship and assembly, under normal use, in accordance with the specifications and warnings, for a period of one year from the date of purchase.

This warranty does not cover damages (a) as a result of an accident; (b) resulting from the use of parts not manufactured or sold by Philips; (c) or resulting from modification of the surge protector. After any repair or modification of the surge protector by a facility not authorized by Philips, any problems that arise will not be remedied under this warranty.

These warranties extend only to the original purchaser of the product, and are not transferable. To exercise your rights under this warranty, you must provide proof of purchase in the form of an original sales receipt that shows the product name and the date of purchase.

For customer support or to obtain warranty service, please visit our website www.philips.com/support. There are no other express or implied warranties. Philips' liability is limited to repair or, at its sole option, replacement of the product. Incidental, special and consequential damages are disclaimed where permitted by law. This warranty gives you specific legal rights. You may also have other rights that vary from state to state.

Connected Equipment Warranty

Philips warrants to the original consumer that it will, at its sole option, repair or replace any equipment properly connected through a Philips surge protector to a properly wired AC power line with protective ground and telephone/coax lines, which is damaged by impulses from lightning, or other power transients, or by momentary (less than 1ms) voltage surges or spikes (an "Occurrence") if (a) the surge protector did not protect the equipment (b) the surge protector shows clear signs of damage; and (c) the damage resulted from the Occurrence.

This warranty does not cover (a) damages caused by acts of God, including flood, erosion, or earthquake, but excluding lightning on products with Power Blocker™ technology; (b) damages caused by a sustained low voltage situation, or a low voltage disturbance, including brownouts, sags, or power outages; (c) damages caused by war, vandalism, theft, normal use wear-and-tear, depletion, obsolescence, abnormal care or uses, or abuse; (d) damage due to non-authorized program or system equipment modification or alteration; or (e) damage to equipment that was not directly connected to the surge protector at the time of the Occurrence.

This warranty extends through the lifetime of the surge protector, which means until the surge protector has exceeded its capacity to

protect against surges and spikes. The “Protection Working” indicator light will no longer be lit when this capacity is exceeded. The capacity of the surge protector will be exceeded after an occurrence.

This warranty is limited to losses that are not covered by a warranty from the manufacturer of the connected equipment, or by the consumer’s homeowners insurance or renter’s insurance policy. Consumer agrees to first seek coverage under any such warranty or policy, and not seek duplicate coverage from Philips. Consumer agrees to provide insurance information to Philips, at its request; and after a claims settlement, if applicable, Philips reserves the right to be subrogated under any existing warranty from the manufacturer of the connected equipment or under any existing insurance policies the claimant may have.

This warranty is limited to surge protectors which indicate on the packaging an accompanying connected equipment warranty. After any repair or modification of the surge protector by a facility not authorized by Philips, any problems that arise will not be remedied under this warranty.

Your Philips surge protector must be plugged into a properly grounded outlet. All connected equipment must be plugged directly into your surge protector. Using any extension cord, adapters, other grounding wires or electrical connections in conjunction with a Philips surge protector will void all Philips warranties. All wires leading into the equipment, including telephone and coaxial lines, must pass through an appropriate Philips surge protector.

To claim damage as a result of telephone service line transients, equipment must be properly connected to a Philips surge protector which offers telephone line protection (see the user manual for installation instructions), and your telephone service equipment must include a properly installed and operating “primary protection” device at the service entrance. (Such devices are normally added during

telephone line installation.) If you fail to connect the telephone line protection properly, your connected equipment will not be covered by the Connected Equipment Warranty.

To claim damage as a result of coaxial line transients, equipment must be properly connected to a Philips surge protector which offers coaxial line protection (see the user manual for installation instructions). If you fail to connect the coaxial cable protection properly, your connected equipment will not be covered by the Connected Equipment Warranty.

The customer service department will provide the consumer with a Return Authorization number (RA#). Philips will determine, at its sole discretion, whether consumer should send the damaged equipment and the surge protector to Philips, or to an independent repair facility. If Philips so requests, the consumer must, at his/her own expense, send the damaged equipment and the surge protector, along with a copy of the sales receipt, to the specified location, in secure packaging (to prevent further damage) with the RA# clearly displayed on the outside of the package, and with a full written description of the problem, including the consumer’s name, address, and daytime phone enclosed. Philips also reserves the right to examine the site where the damage occurred.

If Philips determines that the Connected Equipment Limited Warranty covers the damaged equipment, and that the equipment was damaged as a result of the surge protector which is covered under the Surge Protector Limited Warranty, Philips will either (a) authorize repair of the connected equipment, at a cost up to the maximum amount set forth on the packaging of the surge protector involved; (b) provide the consumer with an equivalent equipment replacement; or (c) reimburse the consumer for the present fair market value of the damaged connected equipment.

To make connected equipment warranty claim, consumer must contact the Philips customer service department at 888-744-5477.



© 2012 Koninklijke Philips Electronics N.V. All rights reserved. Reproduction in whole or in part is prohibited without the written consent of the copyright owner. Trademarks are the property of Koninklijke Philips Electronics N.V. or their respective owners.

SPP1028A_UM_17_V1.0

