

QUICK START

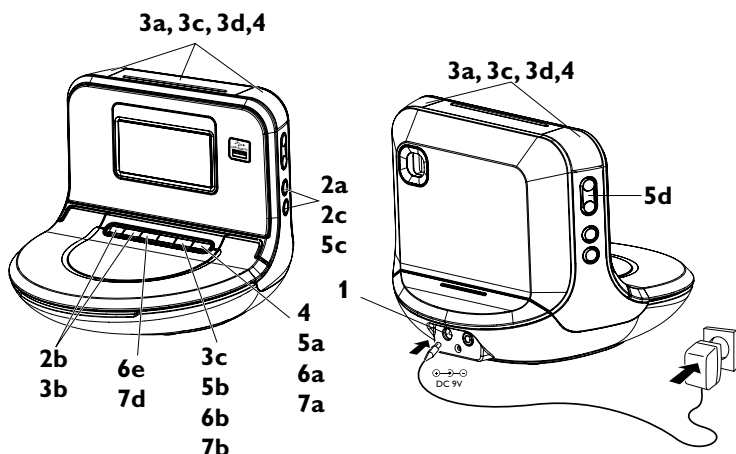

Thanks for buying **Philips AJM180 CD Clock Radio**.
Our **Quick Start** guides you through just some of the features on the set.
Please read our instruction booklet to really rise & shine!

PHILIPS



ENGLISH

1 Power supply

- Connect the supplied mains adapter to the set's 9V DC jack and the plug into a wall outlet.

2 Setting the Clock

- In standby mode, press **PROGRAM/ SET TIME**.
- Press and hold **HOUR/MIN** to adjust time.
- Press **PROGRAM/ SET TIME** to confirm.

3 Setting alarm time and mode

- In standby mode, press **AL1** or **AL2**.
- Press and hold **HOUR/MIN** to adjust time.
- Press **AL1/AL2** again, and then press **SOURCE** to select alarm mode.
- Press corresponding **AL1/AL2** to confirm the setting.

Helpful hints:

- If you have selected **RADIO**, make sure you have properly tuned to a station before turning off the set.

4 Switching off the alarm

- Either press briefly: **AL1/AL2/POWER** or **REPEAT ALARM**.

5 Listening to the Radio

- Press **POWER** to switch on from standby.
- Press **SOURCE** to select **TUNER**.
- Press and hold **PROGRAM/ SET TIME** to program all available stations.
- Press **PRESET/ALBUM ▲▼** until the desired preset station is displayed.

6 Playing a disc

This CD clock radio can play audio discs including CD-R, CD-RW, and MP3.

- Press **POWER** to switch on from standby.
- Press **SOURCE** to select **CD**.
- Lift the CD door to open.
- Insert a CD with the printed side facing up, and close the CD door.
- Press **▶||** to start playback.

7 Playing a USB device

- Press **POWER** to switch on from standby.
- Press **SOURCE** to enter USB mode if USB is NOT displayed.
- Plug a compatible USB mass storage device to AJM180's USB port marked .
- Press **▶||** on your AJM180 to start playback.