

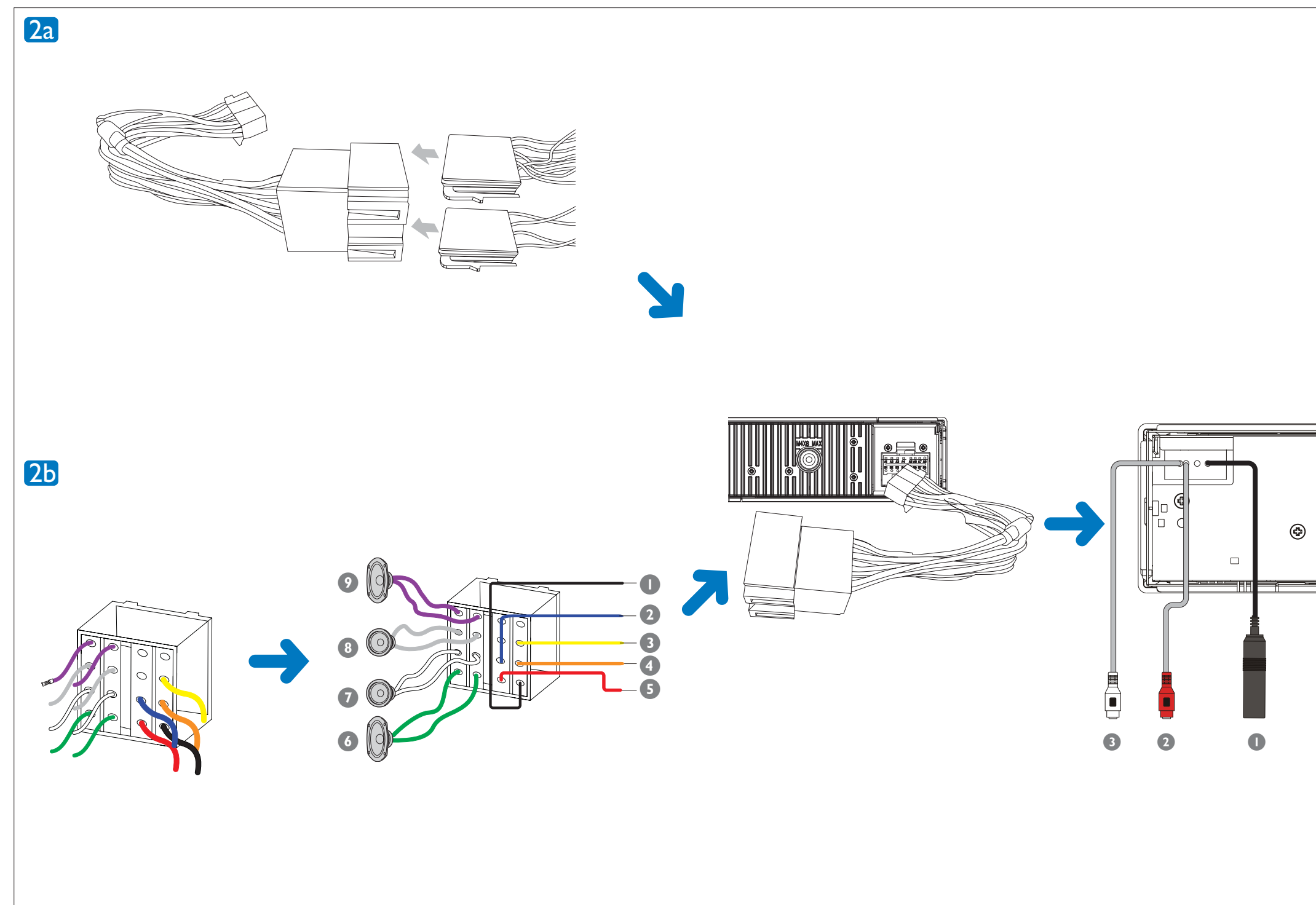

ENG Quick Start Guide

PHILIPS

© 2008 Koninklijke Philips Electronics N.V.
All rights reserved.

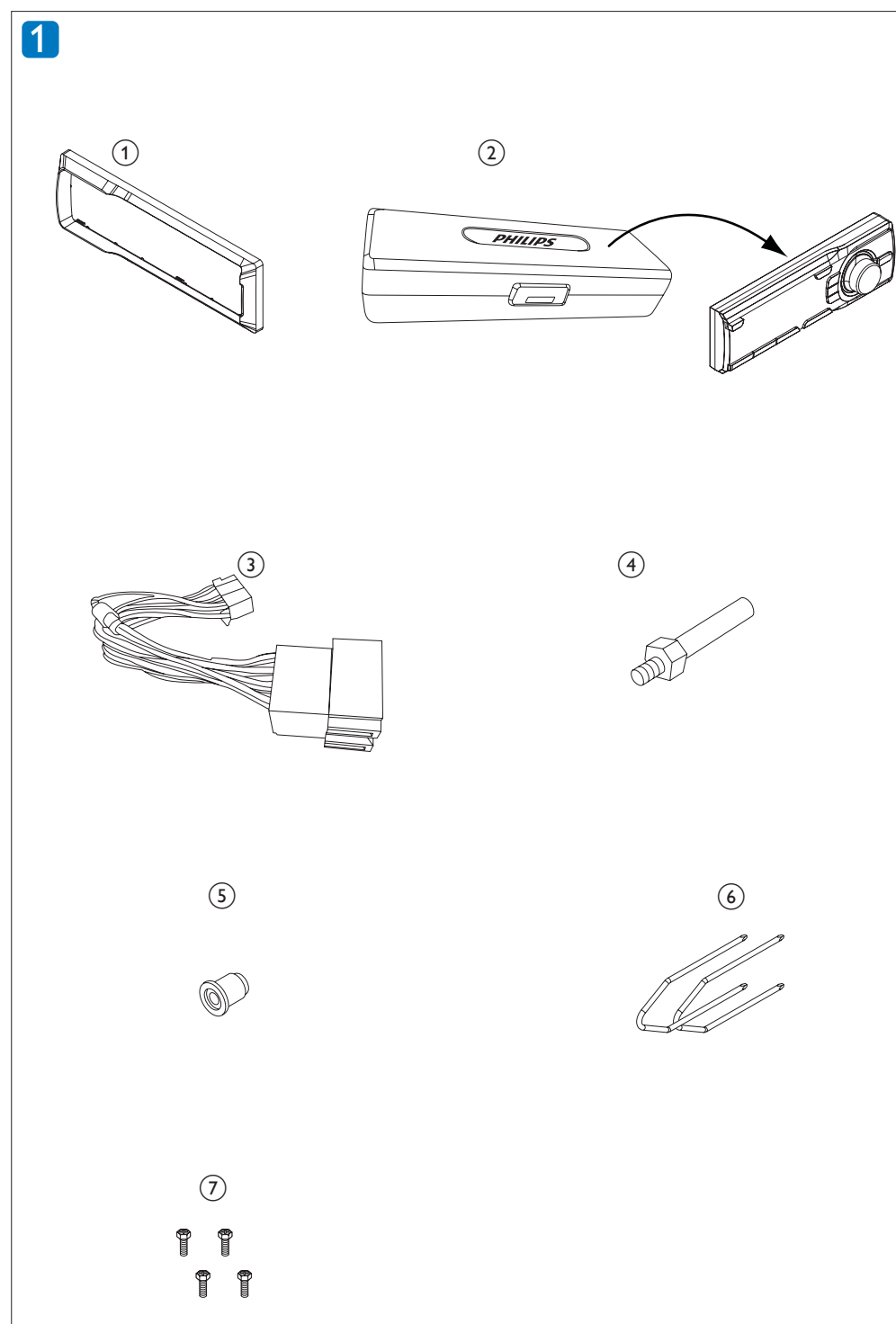

English

Overview of parts 1

These are the supplied parts needed to connect and install this unit.

- ① Carry case with front panel stored inside
- ② Trim plate
- ③ Standard connector
- ④ Disassembly tool x 2 pcs
- ⑤ Rubber cushion
- ⑥ Screw x 4 pcs
- ⑦ Mounting bolt

Connect wires: ISO connectors 2a

- 1 Pull out the ISO connectors from car dashboard and connect them to the bigger end of the supplied standard connector.
- 2 Connect the other end of the supplied standard connector to the unit.
- 3 Do the other connections, if applicable.

| | |
|-------------------------|------------------------------|
| ① Antenna | To antenna |
| ② Rear line out (right) | To amplifier line in (right) |
| ③ Rear line out (left) | To amplifier line in (left) |

Connect wires: without ISO connectors 2b

- 1 Cut off the bigger end of the supplied standard connector.
- 2 Check the car's wiring carefully and connect them to the supplied standard connector.

| | |
|----------------------|---|
| ① Black | To a metal surface of the car First connect the black ground (earth) lead, then connect the yellow and red power supply leads. |
| ② Blue | To the electric antenna control lead or power supply lead of the antenna booster If there is no electric antenna or antenna booster, or it is manually operated telescopic antenna, it is not necessary to connect this lead. |
| ③ Yellow | To the +12V car battery which is energized at all times. |
| ④ Pink | To telephone mute terminal (if any). |
| ⑤ Red | To the +12V power terminal which is energized in the accessory (ACC) position of the ignition switch If there is no accessory position, connect to the +12V car battery terminal that is always live. Be sure to connect the black ground (earth) lead to a metal surface of the car first. |
| ⑥ Green/black strip | Left speaker (Rear) |
| ⑦ White/black strip | Left speaker (Front) |
| ⑧ Gray/black strip | Right speaker (Front) |
| ⑨ Purple/black strip | Right speaker (Rear) |
| ③ | Connect the supplied standard connector to the unit. |
| ④ | Do the other connections, if applicable. |

| | |
|-------------------------|------------------------------|
| ① Antenna | To antenna |
| ② Rear line out (right) | To amplifier line in (right) |
| ③ Rear line out (left) | To amplifier line in (left) |

Attach the front panel 3

- 1 Attach the trim plate.
- 2 Insert the left side of the panel in the chassis until it is correctly engaged.
- 3 Press the right side of the panel until it is locked into place.

Mount into the dashboard 4

Note

- Check wire connection before you mount the unit into a car.
- If preset radio stations are lost when the ignition key is turned OFF and then back ON, reconnect the red leads crosswise to the yellow ones.

- 1 Ensure that car dashboard opening is within these measurements:
 - If the car dashboard is bigger, the supplied mounting sleeve is not suitable for the car. Remove the mounting sleeve with the removal keys and consult a professional for advice.
- 2 If the car does not have an on-board drive or navigation computer, disconnect the negative terminal of the car battery.
 - If you disconnect the car battery in a car that has an on-board drive or navigation computer, the computer may lose its memory.
 - If the car battery is not disconnected, to avoid short-circuit, ensure that bare wires do not touch each other.

- 3 Connect the supplied mounting bolt to the unit.
- 4 Place the supplied rubber cushion over the end of the mounting bolt.
- 5 Slide the unit into the dashboard until you hear a click sound.=
- 6 Reconnect the negative terminal of the car battery.

Detach the front panel 5

- You can detach the front panel to deter theft.
- 1 Press ▲ to release the panel.
 - 2 Pull the panel towards you to detach it from the chassis.
 - 3 Store the panel in the supplied carry case to protect it from dirt or damage.

Turn on

- 1 Press ⏻ to turn on the unit.
 - To turn off the unit, press ⏻ for 3 seconds.

Set clock

- 1 Press MENU/DISP for 3 seconds.
- 2 Press ▲DBB or SEARCH repeatedly until the currently clock is displayed.
- 3 Turn ⏻ in clockwise direction to set hour. Turn in anti-clockwise direction to set minute.
- 4 Press ⏻ to confirm.

View clock

- 1 Press MENU/DISP repeatedly until the clock is displayed.

Tune to a radio station

- 1 Press SOURCE to select Tuner.

- 2 Press ▲DBB or SEARCH to select band: [FM1], [FM2], [FM3], [AM1], or [AM 2].
- 3 Press LOC/DX to select tuner sensitivity: [LOCAL] (local): Only station with strong signal can be broadcast. [DX] (distance): Stations with strong and weak signals can be broadcast.
- 4 Press ◀◀ or ▶▶ to tune to a radio station manually.
 - ↳ The radio station is broadcast.
 - To search for radio station automatically, press ◀◀ or ▶▶ for 3 seconds.

Insert USB device 6

- 1 Open the cover marked USB on the front panel.
- 2 Insert the USB device into the USB socket.
 - ↳ The unit starts playing from the USB device automatically.

Insert SD/MMC card 7

- 1 Open the cover marked SD/MMC on the front panel.
- 2 Insert the SD or MMC card into the card slot.
 - ↳ The unit starts playing from the SD/MMC card automatically.

Control play

- To select a folder, press ▲DBB or SEARCH.
- To skip to a track, press ◀◀ or ▶▶.
- To search within a track, press ◀◀ or ▶▶ for 3 seconds.
- To pause, press 1▶||. To resume, press 1, ▶|| again.



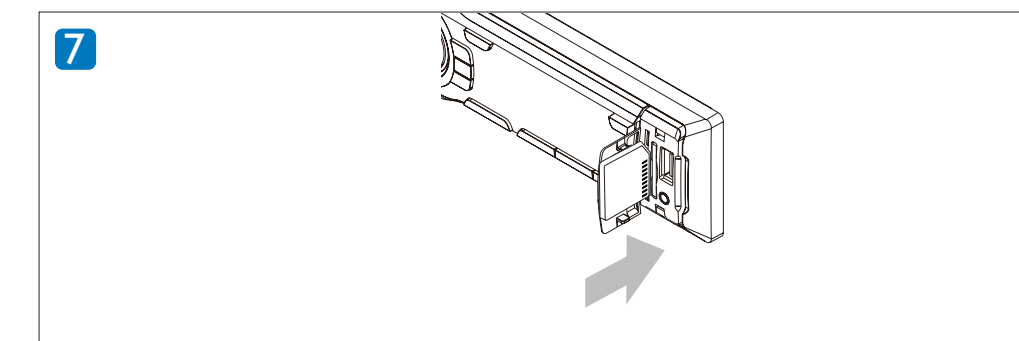
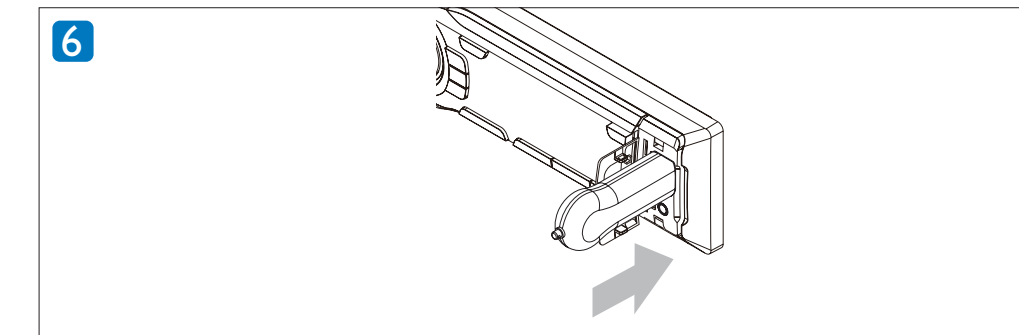
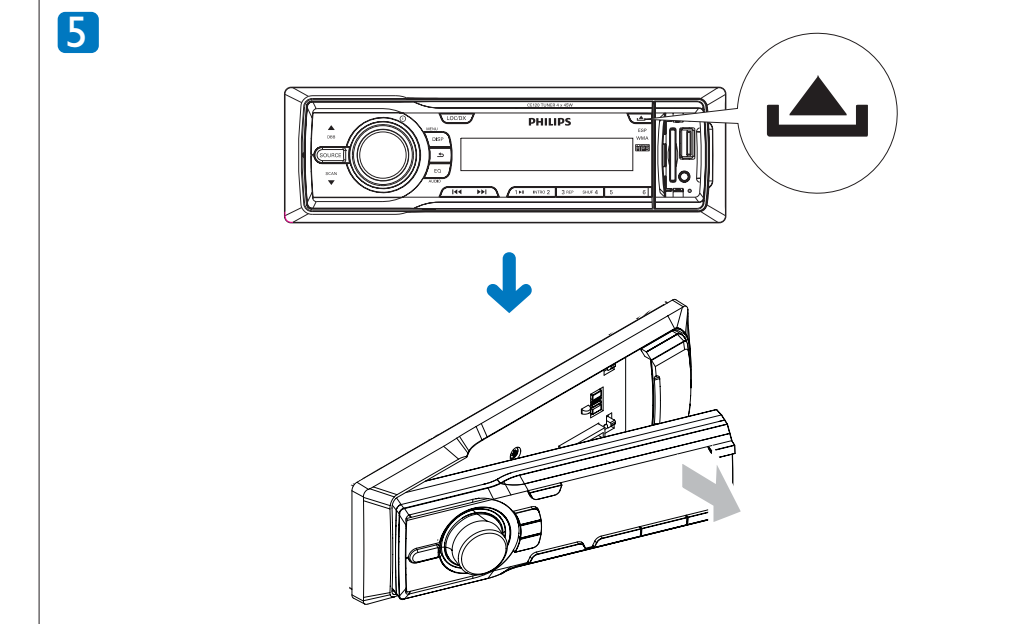
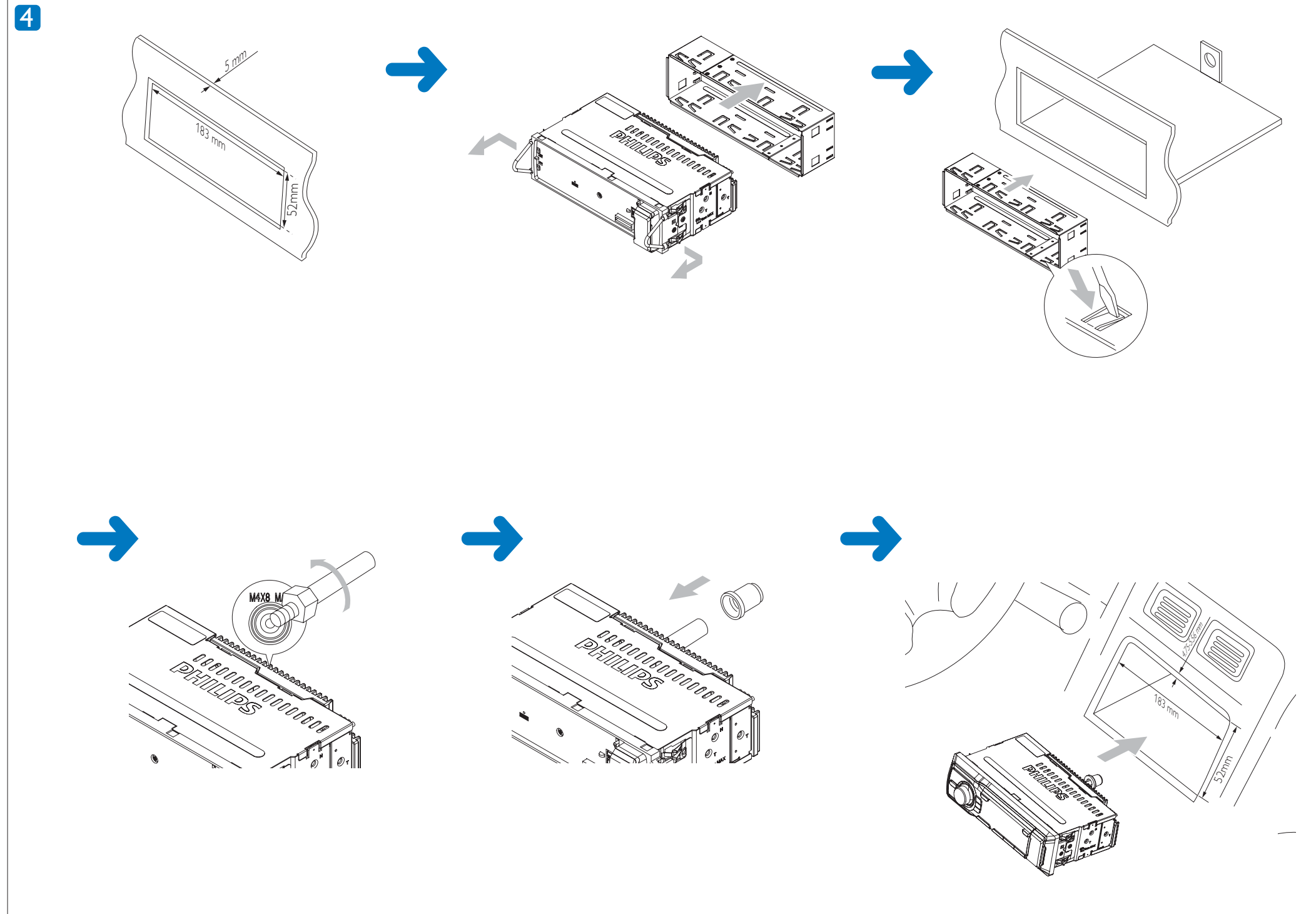
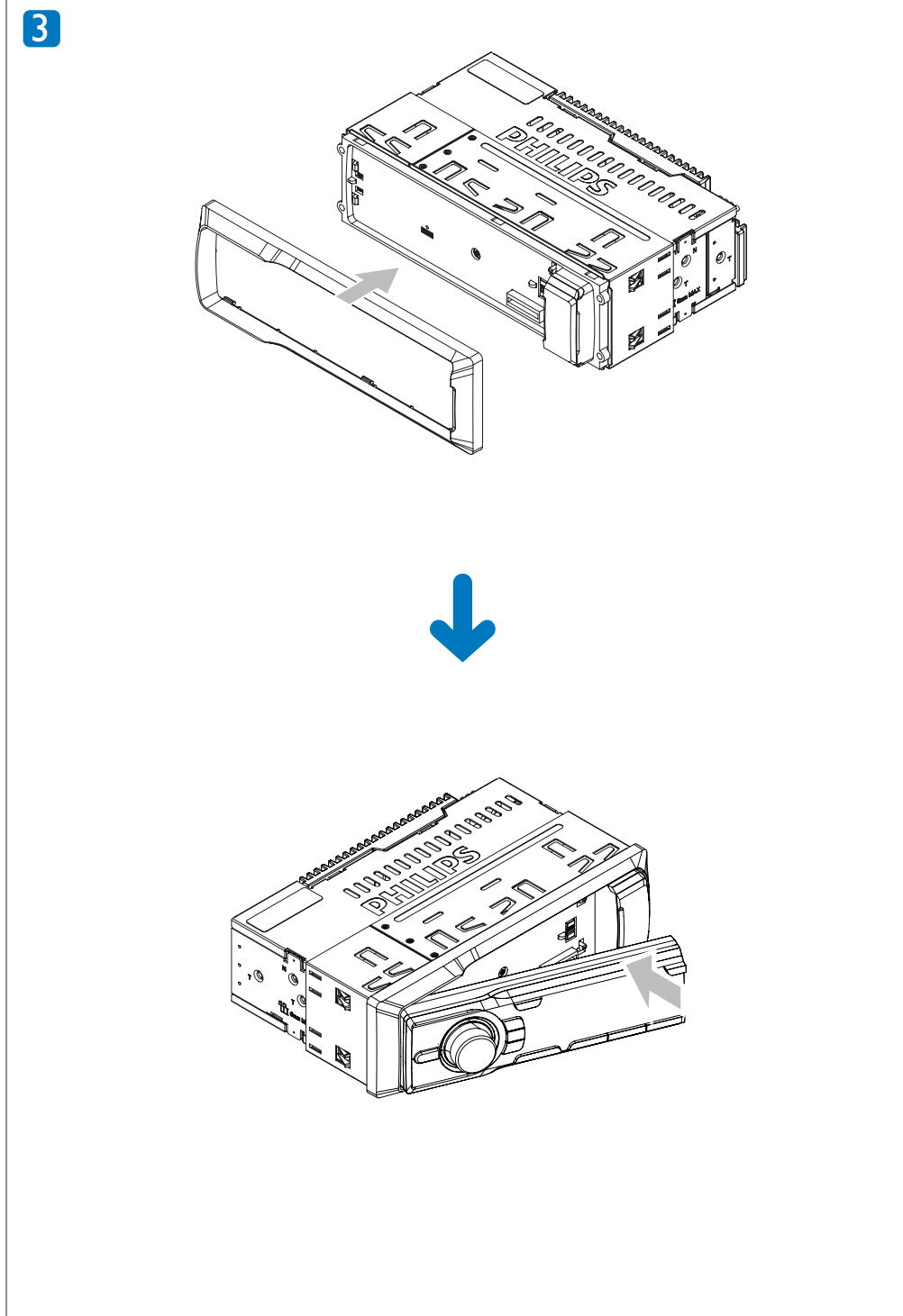

English

Overview of parts 1

These are the supplied parts needed to connect and install this unit.

- ① Carry case with front panel stored inside
- ② Trim plate
- ③ Standard connector
- ④ Disassembly tool x 2 pcs
- ⑤ Rubber cushion
- ⑥ Screw x 4 pcs
- ⑦ Mounting bolt

Connect wires: ISO connectors

2a

- 1 Pull out the ISO connectors from car dashboard and connect them to the bigger end of the supplied standard connector.
- 2 Connect the other end of the supplied standard connector to the unit.
- 3 Do the other connections, if applicable.

| | | |
|---|-----------------------|------------------------------|
| ① | Antenna | To antenna |
| ② | Rear line out (right) | To amplifier line in (right) |
| ③ | Rear line out (left) | To amplifier line in (left) |

Connect wires: without ISO connectors 2b

- 1 Cut off the bigger end of the supplied standard connector.
- 2 Check the car's wiring carefully and connect them to the supplied standard connector.

| | | |
|---|--------------------|--|
| ① | Black | To a metal surface of the car. First connect the black ground (earth) lead, then connect the yellow and red power supply leads. |
| ② | Blue | To the electric antenna control lead or power supply lead of the antenna booster. If there is no electric antenna or antenna booster, or it is manually operated telescopic antenna, it is not necessary to connect this lead. |
| ③ | Yellow | To the +12V car battery which is energized at all times. |
| ④ | Pink | To telephone mute terminal (if any). |
| ⑤ | Red | To the +12V power terminal which is energized in the accessory (ACC) position of the ignition switch. If there is no accessory position, connect to the +12V car battery terminal that is always live. Be sure to connect the black ground (earth) lead to a metal surface of the car first. |
| ⑥ | Green/black strip | Left speaker (Rear) |
| ⑦ | White/black strip | Left speaker (Front) |
| ⑧ | Gray/black strip | Right speaker (Front) |
| ⑨ | Purple/black strip | Right speaker (Rear) |
| ③ | | Connect the supplied standard connector to the unit. |
| ④ | | Do the other connections, if applicable. |

| | | |
|---|-----------------------|------------------------------|
| ① | Antenna | To antenna |
| ② | Rear line out (right) | To amplifier line in (right) |
| ③ | Rear line out (left) | To amplifier line in (left) |

Attach the front panel 3

- 1 Attach the trim plate.
- 2 Insert the left side of the panel in the chassis until it is correctly engaged.
- 3 Press the right side of the panel until it is locked into place.

Mount into the dashboard 4

Note

- Check wire connection before you mount the unit into a car.
- If preset radio stations are lost when the ignition key is turned OFF and then back ON, reconnect the red leads crosswise to the yellow ones.

- 1 Ensure that car dashboard opening is within these measurements:
 - If the car dashboard is bigger, the supplied mounting sleeve is not suitable for the car. Remove the mounting sleeve with the removal keys and consult a professional for advice.
- 2 If the car does not have an on-board drive or navigation computer, disconnect the negative terminal of the car battery.
 - If you disconnect the car battery in a car that has an on-board drive or navigation computer, the computer may lose its memory.
 - If the car battery is not disconnected, to avoid short-circuit, ensure that bare wires do not touch each other.

- 3 Connect the supplied mounting bolt to the unit.
- 4 Place the supplied rubber cushion over the end of the mounting bolt.
- 5 Slide the unit into the dashboard until you hear a click sound.=
- 6 Reconnect the negative terminal of the car battery.

Detach the front panel 5

You can detach the front panel to deter theft.

- 1 Press ▲ to release the panel.
- 2 Pull the panel towards you to detach it from the chassis.
- 3 Store the panel in the supplied carry case to protect it from dirt or damage.

Turn on

- 1 Press ⏻ to turn on the unit.
 - To turn off the unit, press ⏻ for 3 seconds.

Set clock

- 1 Press MENU/DISP for 3 seconds.
- 2 Press ▲DBB or SEARCH▼ repeatedly until the currently clock is displayed.
- 3 Turn ⌚ in clockwise direction to set hour. Turn ⌚ in anti-clockwise direction to set minute.
- 4 Press ⏻ to confirm.

View clock

- 1 Press MENU/DISP repeatedly until the clock is displayed.

Tune to a radio station

- 1 Press SOURCE to select Tuner.

- 2 Press ▲DBB or SEARCH▼ to select band: [FM1], [FM2], [FM3], [AM1], or [AM 2].
- 3 Press LOC/DX to select tuner sensitivity: [LOCAL] (local): Only station with strong signal can be broadcast. [DX] (distance): Stations with strong and weak signals can be broadcast.
- 4 Press ⏪ or ⏩ to tune to a radio station manually.
 - ↳ The radio station is broadcast.
 - To search for radio station automatically, press ⏪ or ⏩ for 3 seconds.

Insert USB device 6

- 1 Open the cover marked USB on the front panel.
- 2 Insert the USB device into the USB socket.
 - ↳ The unit starts playing from the USB device automatically.

Insert SD/MMC card 7

- 1 Open the cover marked SD/MMC on the front panel.
- 2 Insert the SD or MMC card into the card slot.
 - ↳ The unit starts playing from the SD/MMC card automatically.

Control play

- To select a folder, press ▲DBB or SEARCH▼.
- To skip to a track, press ⏪ or ⏩.
- To search within a track, press ⏪ or ⏩ for 3 seconds.
- To pause, press 1⏸. To resume, press 1, ▶▶ again.