

# Micro Hi-Fi System

MCM765

Register your product and get support at

[www.philips.com/welcome](http://www.philips.com/welcome)

User manual



# PHILIPS

**México**



Es necesario que lea cuidadosamente su instructivo de manejo.



Descripción:

**Minisistema de Audio**

Modelo :

**MCM765**

Suministro eléctrico

**110 – 240 V, 60Hz / 50 Hz**

de CA:

Consumo en

**18 W**

funcionamiento:

Importador:

**Philips Mexicana, S.A. de C.V.**

Domicilio:

**Av. La Palma No.6 Col. San**

**Fernando La Herradura**

**Huixquilucan**

Localidad y Tel:

**Edo. de México C.P. 52784**

**Tel.52 69 90 00**

Exportador:

**Philips Electronics HK, Ltd.**

País de Origen:

**China**

Nº de Serie:

**LEA CUIDADOSAMENTE ESTE INSTRUCTIVO  
ANTES DE USAR SU APARATO.**

## **AVISO IMPORTANTE**

*Philips Mexicana, S.A. de C.V. no se hace responsable por daños o desperfectos causados por:*

- Maltrato, descuido o mal uso, presencia de insectos o roedores (cucarachas, ratones etc.).*
- Cuando el aparato no haya sido operado de acuerdo con el instructivo del uso, fuera de los valores nominales y tolerancias de las tensiones (voltaje), frecuencia (ciclaje) de alimentación eléctrica y las características que deben reunir las instalaciones auxiliares.*
- Por fenómenos naturales tales como: temblores, inundaciones, incendios, descargas eléctricas, rayos etc. o delitos causados por terceros (choques asaltos, riñas, etc.).*

## **CAUTION**

**Use of controls or adjustments or performance of procedures other than herein may result in hazardous radiation exposure or other unsafe operation.**

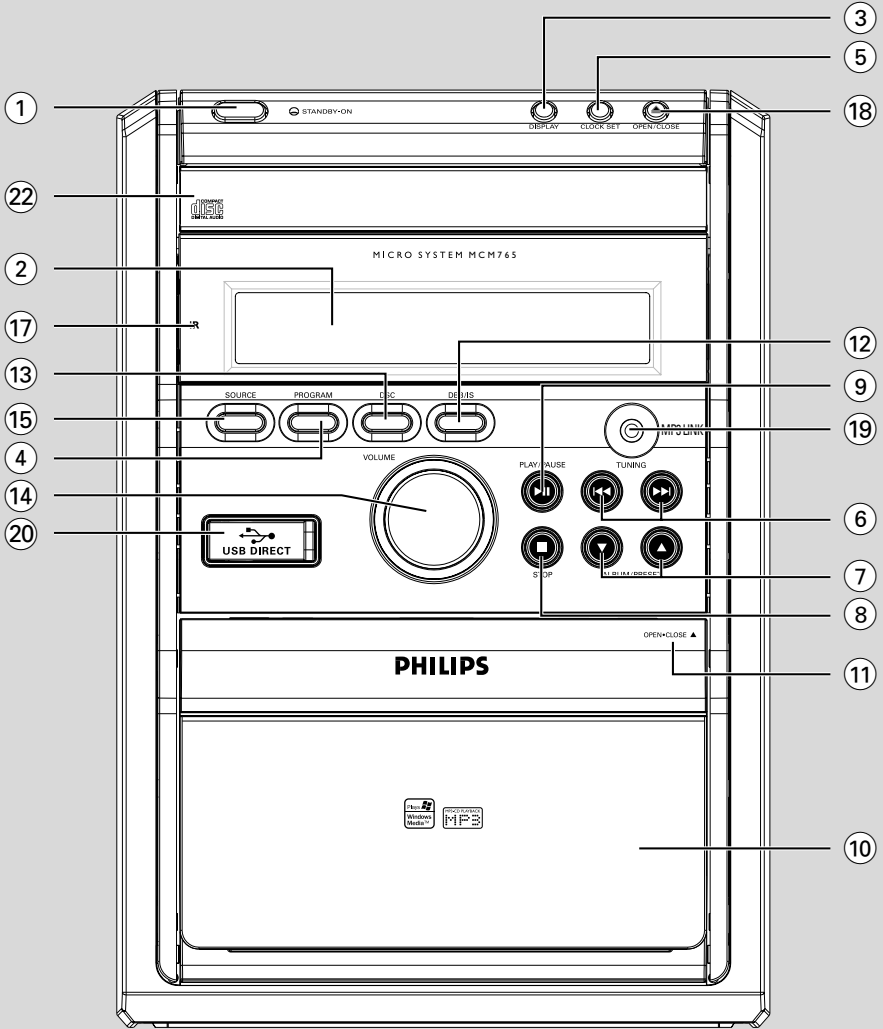

# Contents

---

## General Information

Supplied accessories .....	5
Environmental information .....	5
Safety information .....	5
About MP3 disc .....	5

---

## Preparations

Rear connections .....	6-7
Power	
Antennas connection	
Speakers connection	
Optional connection .....	7
Connecting a USB device or memory card	
Connecting a non-USB device	
Before using the remote control .....	8
Replacing battery (lithium CR2025) into the remote control .....	8

---

## Controls

Controls on the system and remote control .....	9-10
---	------

---

## Basic Functions

Switching the system on .....	11
Switching the system to standby mode .....	11
Power-saving automatic standby .....	11
Volume control .....	11
Sound control .....	11

---

## CD/MP3-CD Operations

Discs for playback .....	12
Playing a disc .....	12
Text display .....	12
Selecting a different track .....	12
Finding a passage within a track .....	13
Selecting a desired Album/Track (MP3 disc only) .....	13
Different play modes: SHUFFLE and REPEAT .....	13
Programming the disc tracks .....	13
Reviewing the programme .....	13
Erasing the programme .....	13

---

## Radio Reception

Tuning to radio stations .....	14
Programming radio stations .....	14
Automatic programming	
Manual programming	
Tuning to preset radio stations .....	14

---

## Tape Operation/Recording

Tape playback .....	15
Rewinding/Fast forwarding .....	15
General information on recording .....	15
Preparation for recording .....	15
Synchro start CD recording .....	16
One touch recording .....	16
Recording timer .....	16

---

## External Sources

Using a non-USB device .....	17
Using a USB mass storage device .....	17-18

---

## Clock/Timer

Clock setting .....	19
Timer setting .....	19
Activating and deactivating timer	
Sleep timer setting .....	19

---

## Specifications

.....	20
-------	----

---

## Maintenance

.....	21
-------	----

---

## Troubleshooting

.....	21-22
-------	-------

Congratulations on your purchase and welcome to Philips!

To fully benefit from the support that Philips offers, register your product at [www.philips.com/welcome](http://www.philips.com/welcome).

---

## Supplied accessories

- 2 speaker boxes
- remote control
- FM wire antenna
- MP3 cable

---

## Environmental Information

All unnecessary packaging has been omitted. We have tried to make the packaging easy to separate into three materials: cardboard (box), polystyrene foam (buffer) and polyethylene (bags, protective foam sheet).

Your system consists of materials which can be recycled and reused if disassembled by a specialised company. Please observe the local regulations regarding the disposal of packaging materials, exhausted batteries and old equipment.

---

## Safety Information

- Before operating the system, check that the operating voltage indicated on the typeplate (or the voltage indication beside the voltage selector) of your system is identical with the voltage of your local power supply. If not, please consult your dealer.
- Place the system on a flat, hard and stable surface.
- The apparatus shall not be exposed to dripping or splashing.
- Place the system in a location with adequate ventilation to prevent internal heat build-up in your system. Allow at least 10 cm (4 inches) clearance from the rear and the top of the unit and 5 cm (2 inches) from each side.
- The ventilation should not be impeded by covering the ventilation openings with items, such as newspapers, table-cloths, curtains, etc.

- Do not expose the system, batteries or discs to excessive moisture, rain, sand or heat sources caused by heating equipment or direct sunlight.
- No naked flame sources, such as lighted candles, should be placed on the apparatus.
- No objects filled with liquids, such as vases, shall be placed on the apparatus.
- If the system is brought directly from a cold to a warm location, or is placed in a very damp room, moisture may condense on the lens of the disc unit inside the system. Should this occur, the CD player would not operate normally. Leave the power on for about one hour with no disc in the system until normal playback is possible.
- The mechanical parts of the set contain self-lubricating bearings and must not be oiled or lubricated.
- Install this unit near the AC outlet and where the AC power plug can be reached easily.
- **When the system is switched to Standby mode, it is still consuming some power. To disconnect the system from the power supply completely, remove the AC power plug from the wall socket.**

---

## About MP3 disc

### Supported formats

- ISO9660, Joliet, Multisession
- Max. track number plus album is 500
- Max. nested directory is 8 levels
- The max. album number is 99
- The max. MP3 programme track number is 20
- Supported VBR bit-rate
- Supported sampling frequencies for MP3 disc are: 32 kHz, 44.1 kHz, 48 kHz
- Supported Bit-rates of MP3 disc are: 32, 64, 96, 128, 192, 256 (kbps)

### Sound Quality

Take note that MP3-CD compilations should best contain only MP3 tracks (.mp3). **To achieve a good MP3 quality, a bit rate of 128 kbps is recommended.**

# Preparations

English

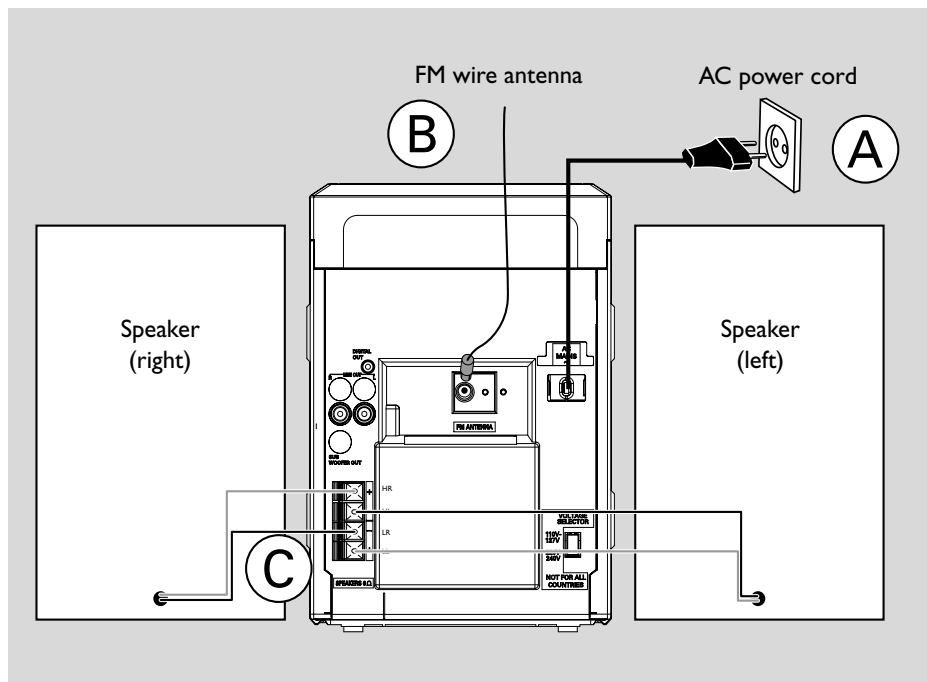

## Rear connections

*The type plate is located at the rear of the system.*

### A Power

Before connecting the AC power cord to the wall outlet, ensure that all other connections have been made.

#### **WARNING!**

- If your system is equipped with a voltage selector, set the **VOLTAGE SELECTOR** to the local power voltage.
- For optimal performance, use only the original power cable.
- Never make or change connections with the power switched on.

*To avoid overheating of the system, a safety circuit has been built in. Therefore, your system may switch to Standby mode automatically under extreme conditions. If this happens, let the system cool down before reusing it (not available for all versions).*

### B Antennas Connection

Connect the supplied FM antenna to the respective terminals. Adjust the position of the antenna for optimal reception.

#### FM Antenna

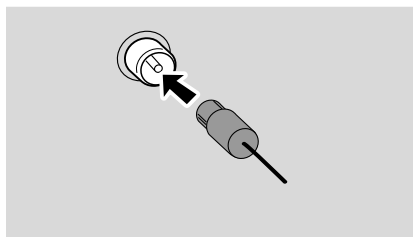

- For better FM stereo reception, connect an outdoor FM antenna to the FM AERIAL (FM ANTENNA) terminal.

## C Speakers Connection

### Front Speakers

There are two groups of wires for each speaker box, one is blue-black wire for high frequency (connect the blue wire to "+" and the black one to "-"), and the other is red-black wire for low frequency (connect the red wire to "+" and black one to "-").

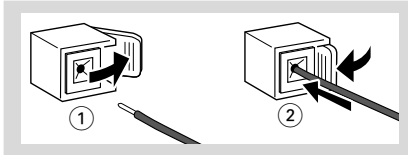

- Fully insert the stripped portion of the speaker wire into the terminal as shown.

#### Notes:

- For optimal sound performance, use the supplied speakers.
- Do not connect more than one speaker to any one pair of +/– speaker terminals.
- Do not connect speakers with an impedance lower than the speakers supplied. Please refer to the SPECIFICATIONS section of this manual.

## Optional connection

The optional equipment and connecting cords are not supplied. Refer to the operating instructions of the connected equipment for details.

### Connecting a USB device or memory card

By connecting a USB mass storage device (including USB flash memory, USB flash players or memory cards) to the Hi-Fi system, you can enjoy the device's stored music through the powerful speakers of Hi-Fi system.

- Insert the USB device's USB plug into the  socket on the set.

OR

#### for the devices with USB cables:

- 1 Insert one plug of the USB cable (not supplied) to the  socket on the set.
- 2 Insert the other plug of the USB cable to the USB output terminal of the USB device.

#### for the memory card:

- 1 Insert the memory card into a card reader (not supplied).
- 2 Use a USB cable (not supplied) to connect the card reader into the  socket on the set.

### Connecting a non-USB device

Use a cinch cable to connect **MP3 LINK** to the analogue audio out terminals of an external equipment (TV,VCR, Laser Disc player, DVD player or CD Recorder).

# Preparations

## Before using the remote control

- 1 Pull out the plastic protective sheet.
- 2 Select the source you wish to control by pressing one of the source select keys on the remote control (for example CD, TUNER).
- 3 Then select the desired function (for example ► || , ◀◀▶▶▶).

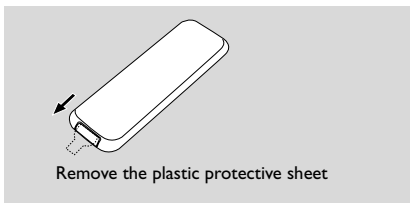

## Replacing battery (lithium CR2025) into the remote control

- 1 Press the slot on the battery compartment.
- 2 Pull out the battery compartment.
- 3 Replace a new battery and fully insert the battery compartment back to the original position.

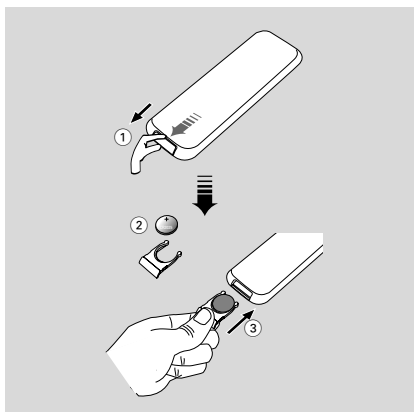

### **CAUTION!**

**Batteries contain chemical substances, so they should be disposed of properly.**



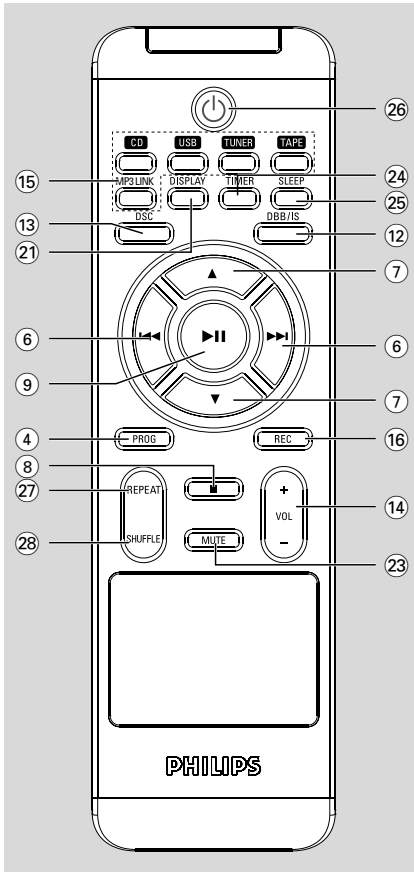



## Controls on the system and remote control

- ① **STANDBY-ON**  $\odot$   
– to switch the system on or to standby mode with clock display.
- ② **Display screen**  
– to view the current status of the system.
- ③ **DISPLAY**  
for CD/MP3-CD/USB...to select disc information display mode.
- ④ **PROGRAM**  
for CD/MP3-CD/USB...to programme disc



- tracks.  
for Tuner .....to programme preset radio stations.
- ⑤ **CLOCK SET**  
for Clock ..... (on the system only) to set the clock function.
- ⑥ **TUNING**  $\left\langle \left\langle \left\langle \right\rangle \right\rangle \right\rangle$  ( $\left\langle \left\langle \right\rangle \right\rangle$ )  
for CD/MP3-CD/USB  
.....to select a desired track.  
..... (press and hold) o search backward/forward.  
for Tuner .....to tune to a lower or higher radio frequency.  
for Tape .....to rewind or fast forward.
- ⑦ **ALBUM/PRESET**  $\nabla/\blacktriangle$   
for MP3-CD/USB to select previous/next album.  
for Tuner .....to select a preset radio station.
- ⑧ **STOP** ■  
for CD/MP3-CD/USB...to stop playback or to clear a programme.  
for Tape .....to stop playback or recording.
- ⑨ **PLAY/PAUSE**  $\blacktriangleright \parallel$   
for CD/MP3-CD/USB...to start or interrupt playback.  
for Tape .....to start playback.
- ⑩ **Tape deck**
- ⑪ **OPEN-CLOSE**  $\blacktriangle$   
– to open tape compartment.
- ⑫ **DBB/IS**  
– to create a super-enhanced stereo effect.  
– to enhance the bass.
- ⑬ **DSC (Digital Sound Control)**  
– to select the desired sound effect : OPTIMAL, ROCK, JAZZ, or POP.
- ⑭ **VOLUME (VOL + / -)**  
– to increase or decrease the volume.  
– to adjust the hours and minutes for the clock/ timer functions.
- ⑮ **SOURCE**  
– to select the respective sound source : CD, USB TUNER, TAPE or MP3 LINK.
- ⑯ **REC**  
– to start recording.

# Controls (main set illustrations on page 3)

---

- ⑰ **iR sensor**
  - infrared sensor for remote control.
- ⑱ **OPEN/CLOSE ▲**
  - to open or close the disc tray.
- ⑲ **MP3 LINK**
  - connect external equipment.
- ⑳ **USB DIRECT **
  - jack for the external USB mass storage device.
- ㉑ **Display**
  - to select disc information display mode.
- ㉒ **Disk tray**
- ㉓ **MUTE**
  - to interrupt and resume sound reproduction.
- ㉔ **TIMER**
  - to activate/deactivate the timer function.
- ㉕ **SLEEP**
  - to activate/deactivate or set the sleep timer.
  - to set the clock function.
- ㉖ ****
  - to switch the system to standby mode.
- ㉗ **REPEAT**
  - to play track(s)/program repeatedly.
- ㉘ **SHUFFLE**
  - to turn on/off the random play mode.

## Notes for remote control:

- **First select the source you wish to control by pressing one of the source select keys on the remote control (for example CD, TUNER).**
- **Then select the desired function (for example , , ).**



### IMPORTANT!

Before you operate the system, complete the preparation procedures.

### Switching the system on

- Press **STANDBY ON**  or **SOURCE**.  
→ The system will switch to the last selected source.
- Press **CD, USB, TUNER, TAPE** or **MP3 LINK** on the remote control.  
→ The system will switch to the selected source.

### Switching the system to Standby mode

- Press **STANDBY ON**  in the active mode.  
→ The system enters the normal standby mode with clock display.  
→ If the clock has not been set, "----:--" is displayed.
- The interactive sound settings, last selected mode, source and tuner presets will be retained in the player's memory.

### Power-saving automatic standby

As a power-saving feature, the system will automatically switch to Standby mode if you do not press any buttons within 15 minutes after a disc, USB, or tape has stopped playing.

### Volume control

Adjust **VOLUME (VOL + / -** on the remote control) to increase or decrease the volume level.

→ Display shows the volume level "VOL" and a number from 1-31. "MIN" denotes the minimum volume level and "MAX" denotes the maximum volume level.

### To switch off the volume temporarily

- Press **MUTE** on the remote control.  
→ Playback will continue without sound and "MUTE" is displayed.
- To restore the volume, press **MUTE** again or increase/decrease the volume level.

### Sound control

- Press **DSC** repeatedly to select the desired sound effect : **OPTIMAL, ROCK, JAZZ** or **POP**.
- Press **DBB/IS** to switch on or off the surround sound effect or bass enhancement.

→ The sequences are as follows :  
**DBB ON** → **INCREDIBLE SURROUND** → **DBB INCREDIBLE SURROUND** → **DBB OFF**

→ If the DBB is activated, **DBB** is shown briefly.

→ If the IS is activated,

**INCREDIBLE SURROUND** scrolls.

→ If both the DBB and IS are activated, **DBB INCREDIBLE SURROUND** scrolls.

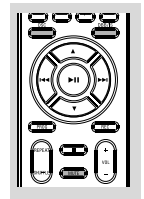

### Note:

– The effect of **INCREDIBLE SURROUND** may vary with different types of music.

# CD/MP3-CD Operations

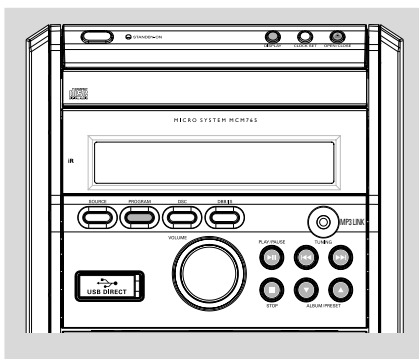

## IMPORTANT!

The lens of the CD player should never be touched.

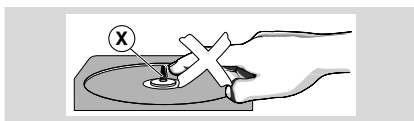

## Discs for playback

This system is able to play :

- All pre-recorded audio CDs
  - All finalised audio CDR and audio CDRW discs
  - MP3-CDs (CD-ROMs with MP3 tracks)
- CD-ROM, CD-I, CDV, VCD, DVD or computer CDs, however, are not possible.

## Playing a disc

- 1 Select **CD** source.
- 2 Press **OPEN/CLOSE** to open the CD compartment.  
→ "CD OPEN" is displayed.
- 3 Insert a disc with the printed side facing up and press **OPEN/CLOSE** to close the CD door.  
→ "READING" is displayed as the CD player scans the contents of a disc, and then the total number of tracks and playing time (or the total number of albums and tracks for MP3 disk) are shown.
- 4 Press **▶||** to start playback.

## To interrupt playback

- Press **▶||**
- To resume playback, press **▶||** again.

## To stop playback

- Press **■**.

### Notes:

- Disc play will also stop when you select another source or the disc has reached the end.
- For MP3 disc, the disc reading time may exceed 10 seconds due to the large number of songs compiled into one disc.

## Text display

### In CD mode

- Press **DISPLAY** (or **DISPLAY** on the remote control) repeatedly to see the following information.
  - Track number and elapsed play time of current track.
  - Remaining play time of current track.
  - Track number and total elapsed time.
  - Track number and total remaining play time.

### In MP3-CD mode

- Press **DISPLAY** (or **DISPLAY** on the remote control) repeatedly to select four display modes :  
**Number** → The current album and track numbers are displayed briefly.  
**Track** → The current track name scrolls twice.  
**Album** → The current album name scrolls twice.  
**ID-3** → The ID-3 tag scrolls twice.

## Selecting a different track

- Press **TUNING** (or on the remote control) repeatedly until the desired track number appears in the display.
- If playback is stopped, press **▶||** to start playback.

## Finding a passage within a track

- 1 Press and hold down on **TUNING** |◀◀/▶▶| (◀◀▶▶| on the remote control).  
→ The disc is played at high speed.
- 2 When you recognize the passage you want, release **TUNING** |◀◀/▶▶| (◀◀▶▶| on the remote control).  
→ Normal playback continues.

## Selecting a desired album/track

### To select a desired album (MP3 disc only)

- Press **ALBUM/PRESET** ▼/▲ repeatedly.

### To select a desired track

- Press **TUNING** |◀◀/▶▶| (◀◀▶▶| on the remote control) repeatedly.

## Different play modes: SHUFFLE and REPEAT

You can select and change the various play modes before or during playback.

- 1 Press **REPEAT** and **SHUFFLE** on the remote control to select :  
→ **REP** – to repeat the current track.  
→ **REP ALL** – to repeat the entire disc/ programme.  
→ **SHUF** – tracks of the entire disc/ programme are played in random order.  
→ **SHUF REP ALL** – to repeat the entire disc/ programme continuously in random order.
- 2 To return to normal playback, press **REPEAT** and **SHUFFLE** until the various SHUFFLE/ REPEAT modes are no longer displayed.
- You can also press ■ to cancel your play mode.

### Note:

*If Shuffle is activated on a MP3-CD, all titles stored in the disc will be played in random order.*

## Programming the disc tracks

Programming tracks is possible when playback is stopped. Up to 20 tracks can be stored in the memory in any order.

- 1 Press **PROGRAM** to enter the programming mode.  
→ A track number is shown and **PROG** flashes.
- 2 Press **TUNING** |◀◀/▶▶| (◀◀▶▶| on the remote control) repeatedly to select your desired track number.
- For MP3 disc, press **ALBUM/PRESET** ▼/▲ and **TUNING** |◀◀/▶▶| (◀◀▶▶| on the remote control) to select the desired album and track for programming.
- 3 Press **PROGRAM** to confirm the track number to be stored.
- 4 Repeat steps 2-3 to select and store all desired tracks.
- 5 Pressing ► || button will start playback of the programmed tracks.
- **If you attempt to programme more than 20 tracks, "FULL" will appear on the display. In this case :**  
→ The system will exit programming mode automatically.  
→ Pressing ■ button will erase all the programmed tracks.  
→ Pressing ► || button will start playback of the programmed tracks.

## Reviewing the programme

In stop mode, press and hold **PROGRAM** until the display shows all your stored track numbers in sequence.

## Erasing the programme

- Press ■ **once** when playback is stopped or **twice** during playback.  
→ **PROG** disappears and "CLEAR" is displayed.

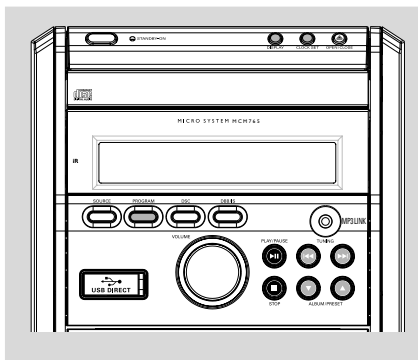

## Tuning to radio stations

- 1 Press **SOURCE** on the front panel repeatedly (or **TUNER** on the remote control) to select FM mode.
- 2 Hold **TUNING** |◀◀/ ▶▶| and then release the button.  
→ The display will show "SEARCH" until a radio station with sufficient signal strength is found.  
→ If a FM station is received in stereo, **∞** is shown.
- 3 Repeat step 2 if necessary until you find the desired station.
- To tune to a weak station, press **TUNING** |◀◀/ ▶▶| briefly and repeatedly until you have found optimal reception.

## Programming radio stations

You can store up to 40 radio stations in the memory.

### Automatic programming

Automatic programming will start with a chosen preset number. From this preset number upwards, former programmed radio stations will be overridden.

- 1 Press **ALBUM/PRESET** ▼/▲ to select the preset number where programming should start.

*Note:*

→ If no preset number is selected, default is preset (1) and all your presets will be overridden.

- 2 Press **PROGRAM** for more than two seconds to activate programming.  
→ All available stations are programmed.

### Manual programming

- 1 Tune to your desired station (refer to "Tuning to radio stations").
- 2 Press **PROGRAM** to activate programming.  
→ **PROG** flashes in the display.
- 3 Press **ALBUM/PRESET** ▼/▲ to allocate a number from 1 to 40 to this station.
- 4 Press **PROGRAM** again to confirm the setting.  
→ **PROG** disappears, the preset number and the frequency of the preset station are shown.
- 5 Repeat the above four steps to store other stations.
- You can override a preset station by storing another frequency in its place.

## Tuning to preset radio stations

- Press **ALBUM/PRESET** ▼/▲ until the desired preset station is displayed.

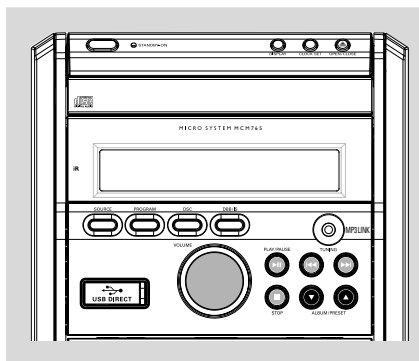

## Tape playback

- 1 Select **TAPE** source.  
→ The display shows "**TAPE**" briefly, and the tape counter  $\square\square\square$  is displayed.
- 2 Press **OPEN•CLOSE ▲** to open the tape door.
- 3 Insert a recorded tape and close the tape door.
- Load the tape with the open side downward and the full spool to the left.
- 4 Press **▶||** to start playback.

### To stop playback

- Press **■**.

### To reset the tape counter display

- In stop mode, press **■ once**.

## Rewinding/Fast forwarding

- 1 Press **TUNING |◀◀▶▶|** (◀◀▶▶ on the remote control).  
→ The tape will stop automatically at the end of rewinding or fast forwarding.  
→ During fast winding, you can monitor the tape message with the tape counter.
- 2 Press **■** to stop rewinding or fast forwarding.

## General information on recording

- For recording, use only NORMAL (IEC type I) tapes on which the tabs have not yet been broken. This deck is not suited for recording on METAL (IEC IV) type tapes.
- The best recording level is set automatically. Altering the VOLUME, INCREDIBLE SURROUND or DBB will not affect the recording in progress.
- At the very beginning and end of the tape, no recording will take place during the 7 seconds when the leader tape passes the recorder heads.
- To protect a tape from accidental erasure, have the tape in front of you and break out the left tab. Recording on this side is no longer possible. If, however, you wish to record over this side again, cover the tabs with a piece of adhesive tape.

### IMPORTANT!

**Recording is permissible if copyright or other rights of third parties are not infringed upon.**

## Preparation for recording

- 1 Select **TAPE** source.
- 2 Load a recordable tape into tape deck with full spool to the left.
- 3 Prepare the source to be recorded.  
**CD** – load the disc.  
**TUNER** – tune to the desired radio station.  
**MP3 LINK** – connect external equipment.

### When recording is in progress

→ **REC** flashes.

- To stop recording, press **■**.
- It is not possible to listen to another source.

## Synchro start CD recording

- 1 Select **CD** source.
- 2 Press **TUNING** |◀◀/▶▶| (◀◀▶▶) on the remote control) to select the desired track to start recording.
- 3 You can programme the tracks in the order you want them to be recorded (refer to "CD/MP3-CD Operations - Programming the disc tracks").
- 4 Press **REC** on the remote control to start recording.  
→ Playing of the CD programme starts automatically from the beginning of the CD. It is not necessary to start the CD player separately.

## One touch recording

- 1 Select **CD**, **TUNER** or **MP3 LINK** source.
- 2 If necessary, start playback of the selected source.
- 3 Press **REC** to start recording.

## Recording timer

To record from the radio, you will need to use a preset radio station and to set a start (ON) and finish (OFF) time.

- 1 Select the preset radio station to record from (refer to "Radio Reception - Tuning to preset radio stations").
- 2 In standby mode, press **TIMER** on the remote control for more than two seconds.  
→ The current selected source is displayed.
- 3 Press **SOURCE** repeatedly until "RECTUN" source is displayed.
- 4 Press **TIMER** to confirm the source.  
→ "SET ON TIME" is displayed and the clock digits for the hours flash.

- 5 Adjust **VOLUME** on the front panel to set the hours.
- 6 Press **TIMER** again.  
→ The clock digits for the minutes flash.
- 7 Adjust **VOLUME** on the front panel to set the minutes.
- 8 Press **TIMER** to confirm the recording start time.  
→ "SET OFF TIME" is displayed and the clock digits for the hours flash.
- 9 Repeat steps 5-7 to set the finish time.
- 10 Press **TIMER** to confirm the timer settings.  
→ ⌚ is shown and the recording timer is now set.

### Note:

– The recording timer will not be activated if the system is in tape play mode.

## ORIGINAL COPYRIGHT NOTICE

The making of unauthorized copies of copy-protected material, including computer programmes, files, broadcasts and sound recordings, may be an infringement of copyrights and constitute a criminal offence. This equipment should not be used for such purposes.



Be responsible  
Respect copyrights



## Using a non-USB device

- 1 Connect the audio out terminals of the external equipment (TV,VCR, Laser Disc player, DVD player or CD Recorder) to the **MP3 LINK** terminals of your system.
- 2 Press **MP3 LINK** to select external equipment.

### Note:

- All the sound control features (DSC or DBB, for example) are available for selection.
- Refer to the operating instructions for the connected equipment for details.

**For Recording, please refer to “Tape Operation/Recording”.**

## Using a USB mass storage device

By connecting a USB mass storage device to the Hi-Fi system, you can enjoy the device’s stored music through the powerful speakers of Hi-Fi system.

### Playing a USB mass storage device Compatible USB mass storage devices

With the Hi-Fi system, you can use:

- USB flash memory (USB 2.0 or USB1.1)
- USB flash players (USB 2.0 or USB1.1)
- memory cards (requires an additional card reader to work with this Hi-Fi system)

### Note:

- In some USB flash players (or memory devices), the stored contents are recorded using copyright protection technology. Such protected contents will be unplayable on any other devices (such as this Hi-Fi system).
- Switch on the USB device only after it is connected to the Micro system.

### Supported formats:

- USB or memory file format FAT12, FAT16, FAT32 (sector size: 512 - 4,096 bytes)
- MP3 bit rate (data rate): 32-320 Kbps and variable bit rate
- WMA v9 or earlier
- Directory nesting up to a maximum of 8 levels
- Number of albums/ folders: maximum 99
- Number of tracks/titles: maximum 500
- ID3 tag v2.0 or later
- File name in Unicode UTF8 (maximum length: 128 bytes)

### The system will not play or support the following:

- Empty albums: an empty album is an album that does not contain MP3/WMA files, and will not be shown in the display.
- Non-supported file formats are skipped. This means that e.g.: Word documents .doc or MP3 files with extension .dlf are ignored and will not be played.
- AAC, WAV, PCM audio files
- DRM protected WMA files
- WMA files in Lossless format

### How to transfer music files from PC to a USB mass storage device

By dragging and dropping music files, you can easily transfer your favorite music from PC to a USB mass storage device.

For the flash player, you can also use its music management software for the music transfer.

**However, those WMA files may be unplayable for compatibility reasons.**

## How to organize your MP3/WMA files on the USB mass storage device

This Hi-Fi system will browse the MP3/WMA files in the folders/sub-folders/titles order.  
Example:

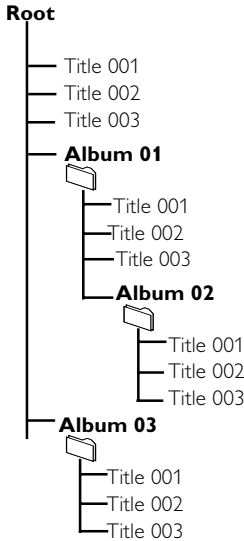

Organize your MP3/WMA files in different folders or subfolders as required.

### Notes:

- If you have not organized MP3/WMA files into any albums on your disc, an album "01" will be automatically assigned for all those files.
- Make sure that the file names of MP3 files end with `.mp3`, and the file names of WMA files end with `.wma`.
- For DRM protected WMA files, use Windows Media Player 10 (or later) for conversion. Visit [www.microsoft.com](http://www.microsoft.com) for details about Windows Media Player and WM DRM (Windows Media Digital Rights Management).

- 1 Check the USB device has been properly connected. (See Installation: Connecting an additional appliance).
- 2 Press **SOURCE (USB)** on the remote control) once or more to select USB.  
-NO TRACK appears if no audio file is found in the USB device.

- 3 Play the USB's audio files as you do with the albums/tracks on a CD (See CD/MP3 Operations).

### Notes:

- For compatibility reasons, the album/track information may differ from what it is displayed through flash players' music management software.
- File names or ID3 tags will be displayed as — if they are not in English.

## IMPORTANT!

### Compatibility of the USB connection on this product:

- This product supports most USB Mass storage devices (MSD) that are compliant to the USB MSD standards.
  - Most common Mass storage class devices are flash drives, memory sticks, jump drives and etc.
  - If you see a "Disc Drive" show up on your computer after you plugged the mass storage device into your computer, most likely it is MSD compliant and it will work with this product.
- If your Mass storage device required a battery/ power source. Please make sure you have a fresh battery in it or charge the USB device first and then plug it into the product again.

### Supported Music type:

- This device only supports unprotected music with the following file extension:  
`.mp3`  
`.wma`
- Music bought from on-line music stores are not supported because they are secured by Digital Rights Management protection (DRM).
- File name extensions that end with the following are not supported:  
`.wav`; `.m4a`; `.m4p`; `mp4`; `.aac` and etc.

**No Direct connection can be made from Computer USB port to the product even you have either or both mp3 or wma files in your computer.**



## Clock setting

The clock can be set in either 12-hour or 24-hour mode ("AM 12:00" or "00:00" for example).

- 1 In standby mode, press and hold **CLOCK SET**.  
→ SET CLK is displayed briefly. Then, clock digits for the hours flash.
- 2 Press **■** on the remote control to select clock mode.  
→ Then, the clock digits for the hours continue to flash.
- 3 Adjust **VOLUME** to set the hours.
- 4 Press **CLOCK SET** again.  
→ The clock digits for the minutes flash.
- 5 Adjust **VOLUME** to set the minutes.
- 6 Press **CLOCK SET** to confirm the time.

## Timer setting

- The system can be used as an alarm clock, whereby the CD, TUNER or TAPE is switched on at a set time (one time operation). The clock time needs to be set first before the timer can be used.
- You can also use it to record a favourite tuner programme at a set period (refer to "Recording timer")
- During setting, if no button is pressed within 15 seconds, the system will exit timer setting mode automatically.

- 1 In standby mode, press **TIMER** on the remote control for more than two seconds.
- 2 Press **SOURCE** repeatedly to select the sound source.  
→ "SET TIME" and "SELECT SOURCE" are displayed.
- 3 Press **TIMER** to confirm your desired mode.  
→ "SET ON TIME" is displayed and the clock digits for the hours flash.
- 4 Adjust **VOLUME** to set the hours.
- 5 Press **TIMER** again.  
→ The clock digits for the minutes flash.
- 6 Adjust **VOLUME** to set the minutes.
- 7 Press **TIMER** to confirm the time.  
→ The timer is now set and activated.

## Activating and deactivating timer



- In standby or during playback, press **TIMER** on the remote control once.  
→ Display shows  if activated, and disappears if deactivated.

## Sleep timer setting

The sleep timer enables the system to switch off by itself after a set period of time.

- 1 Press **SLEEP** on the remote control repeatedly to select a preset time.  
→ The selections are as follows (time in minutes):  
**15 → 30 → 45 → 60 → 0 → 15 ...**  
→ "SLEEP XX" is displayed. "XX" is the time in minutes.
- 2 When you reach the desired length of time, stop pressing **SLEEP**.  
→ "SLEEP" is displayed.

## To deactivate the sleep timer

- Press **SLEEP** repeatedly until "SLEEP  is displayed, or press **STANDBY-ON** .

## AMPLIFIER

Output power ..... 4 x 75 W RMS\*  
 Signal-to-noise ratio .....  $\geq$  62 dBA (IEC)  
 Frequency response ..... 40 – 15000 Hz,  $\pm$  3 dB  
 Impedance loudspeakers ..... 4  $\Omega$   
 Impedance headphones ..... 32  $\Omega$   
 \* (4  $\Omega$ , 1 kHz, 10% THD)

## CD/MP3-CD PLAYER

Number of programmable tracks ..... 20  
 Frequency range ..... 20 – 20000 Hz  
 Signal-to-noise ratio ..... 75 dBA  
 Channel separation .....  $\geq$  60 dB (1 kHz)  
 Total harmonic distortion .....  $<$  0.5%  
 MPEG 1 Layer 3 (MP3-CD) ..... MPEG AUDIO  
 MP3-CD bit rate ..... 32-256 kbps  
 (128 kbps advised)  
 Sampling frequencies ..... 32, 44.1, 48 kHz

## USB PLAYER

USB ..... 12Mb/s, V1.1  
 ..... support MP3 and WMA files  
 Number of albums/folders ..... maximum 99  
 Number of tracks/titles ..... maximum 500

## TUNER

FM wave range ..... 87.5 – 108 MHz  
 Sensitivity at 75  $\Omega$   
 – mono, 26 dB signal-to-noise ratio ..... 2.8  $\mu$ V  
 – stereo, 46 dB signal-to-noise ratio ..... 61.4  $\mu$ V  
 Total harmonic distortion .....  $\leq$  5%  
 Frequency response ..... 63 – 12500 Hz ( $\pm$  3 dB)  
 Signal-to-noise-ratio .....  $\geq$  50 dBA

## TAPE DECK

Frequency response  
 Normal tape (type I) ..... 80 – 12500 Hz (8 dB)  
 Signal-to-noise ratio  
 Normal tape (type I) ..... 50 dBA  
 Wow and flutter .....  $\leq$  0.4% DIN

## SPEAKERS

System 2-way, double port bass reflex  
 Woofer ..... 1x13 cm  
 Tweeter ..... 1x5 cm

## GENERAL INFORMATION

AC Power ..... 110 – 240V, 60Hz / 50 Hz  
 Standby Power Consumption .....  $\leq$  18 W  
 Dimensions (w x h x d)  
 – Main unit (w x h x d) ..... 175 x 252 x 360 mm  
 – Speaker box (w x h x d) 175 x 252 x 214 mm  
 Weight  
 With packing ..... 10.16 kg  
 Main unit ..... 3.18 kg  
 Speaker box ..... 5.36 kg

**Specifications and external appearance are subject to change without notice.**

# Maintenance

## Cleaning the Cabinet

- Use a soft cloth slightly moistened with a mild detergent solution. Do not use a solution containing alcohol, spirits, ammonia or abrasives.

## Cleaning Discs

- When a disc becomes dirty, clean it with a cleaning cloth. Wipe the disc from the centre out.
- Do not use solvents such as benzene, thinner, commercially available cleaners, or antistatic spray intended for analogue records.



## Cleaning the disc lens

- After prolonged use, dirt or dust may accumulate at the disc lens. To ensure good playback quality, clean the disc lens with Philips CD Lens Cleaner or any commercially available cleaner. Follow the instructions supplied with cleaner.

## Cleaning the Heads and the Tape Paths

- To ensure good recording and playback quality, clean the heads (A), the capstan(s) (B), and pressure roller(s) (C) after every 50 hours of tape operation.

**Caution: Do not rotate the heads during cleaning.**

- Use a cotton swab slightly moistened with cleaning fluid or alcohol.
- You can also clean the heads by playing a cleaning tape once.

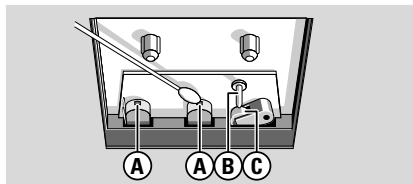

## Demagnetizing the heads

- Use a demagnetizing tape available at your dealer.

# Troubleshooting

## WARNING

**Under no circumstances should you try to repair the system yourself, as this will invalidate the warranty. Do not open the system as there is a risk of electric shock.**

**If a fault occurs, first check the points listed below before taking the system for repair. If you are unable to remedy a problem by following these hints, consult your dealer or Philips for help.**

Problem	Solution
<b>"NO DISC" is displayed.</b>	<ul style="list-style-type: none"><li>✓ Insert a disc.</li><li>✓ Check if the disc is inserted upside down.</li><li>✓ Wait until the moisture condensation at the lens has cleared.</li><li>✓ Replace or clean the disc, see "Maintenance".</li><li>✓ Use a finalised CD-RW or CD-R.</li></ul>
<b>Radio reception is poor.</b>	<ul style="list-style-type: none"><li>✓ If the signal is too weak, adjust the antenna or connect an external antenna for better reception.</li><li>✓ Increase the distance between the Micro HiFi System and your TV or VCR.</li></ul>

Problem	Solution
<b>Recording or playback cannot be made.</b>	<ul style="list-style-type: none"> <li>✓ Clean deck parts, see "Maintenance".</li> <li>✓ Use only normal (IEC I) tape for recording.</li> </ul>
<b>"CHK TAPE" is displayed.</b>	<ul style="list-style-type: none"> <li>✓ Apply a piece of adhesive tape over the missing tab space.</li> </ul>
<b>The tape deck door cannot open.</b>	<ul style="list-style-type: none"> <li>✓ Remove and reconnect the AC power plug and switch on the system again.</li> </ul>
<b>The system does not react when buttons are pressed.</b>	<ul style="list-style-type: none"> <li>✓ Remove and reconnect the AC power plug and switch on the system again.</li> </ul>
<b>Sound cannot be heard or is of poor quality.</b>	<ul style="list-style-type: none"> <li>✓ Adjust the volume.</li> <li>✓ Disconnect the headphones.</li> <li>✓ Check that the speakers are connected correctly.</li> <li>✓ Check if the stripped speaker wire is clamped.</li> <li>✓ Make sure the MP3-CD was recorded within 32-256 kbps bit rate with sampling frequencies at 48 kHz, 44.1 kHz or 32 kHz.</li> </ul>
<b>The left and right sound outputs are reversed.</b>	<ul style="list-style-type: none"> <li>✓ Check the speaker connections and location.</li> </ul>
<b>The remote control does not function properly.</b>	<ul style="list-style-type: none"> <li>✓ Select the source (CD or TUNER, for example) before pressing the function button (▶ II,  ◀▶▶▶ ).</li> <li>✓ Reduce the distance between the remote control and the system.</li> <li>✓ Insert the batteries with their polarities (+/- signs) aligned as indicated.</li> <li>✓ Replace the batteries.</li> <li>✓ Point the remote control directly toward IR sensor on the front of the system.</li> </ul>
<b>The timer is not working.</b>	<ul style="list-style-type: none"> <li>✓ Set the clock correctly.</li> <li>✓ Press <b>TIMER</b> on the remote control) to switch on the timer.</li> <li>✓ If a recording is in progress, stop the recording.</li> </ul>
<b>The Clock/Timer setting is erased.</b>	<ul style="list-style-type: none"> <li>✓ Power has been interrupted or the power cord has been disconnected. Reset the clock/timer.</li> </ul>
<b>Some files on the USB device are not displayed.</b>	<ul style="list-style-type: none"> <li>✓ Check if the number of folders exceeds 99 or the number of titles exceeds 500.</li> </ul>
<b>"DEVICE NOT SUPPORTED" scrolls on the display.</b>	<ul style="list-style-type: none"> <li>✓ Remove the USB mass storage device or select another source.</li> </ul>