

Sempre perto para ajudá-lo

Registre seu produto e obtenha suporte em www.philips.com/support

Dúvidas? Entregue em contato com a Philips



Imagem meramente ilustrativa

Guia de Início Rápido

PHILIPS

FX10



PRODUZIDO NO POLO INDUSTRIAL DE MANAUS
CONHEÇA A AMAZÔNIA



Este produto contém a placa F-6688 código de homologação ANATEL 0846-15-4950

2016 © Gibson Innovations Limited. All rights reserved. This product has been manufactured by, and is sold under the responsibility of Gibson Innovations Ltda., and Gibson Innovations Ltd. is the warrantor in relation to this product. Philips and the Philips Shield Emblem are registered trademarks of Koninklijke Philips N.V. and are used under license from Koninklijke Philips N.V.

3106 305 59791 - FX10X_78_QSG_V1.0

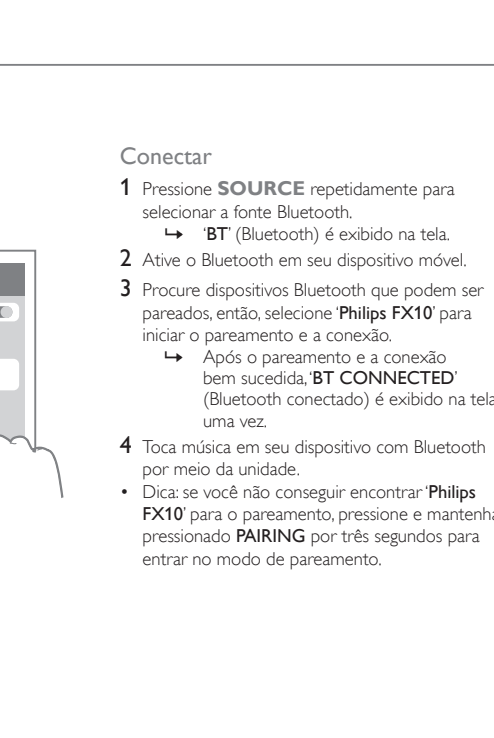
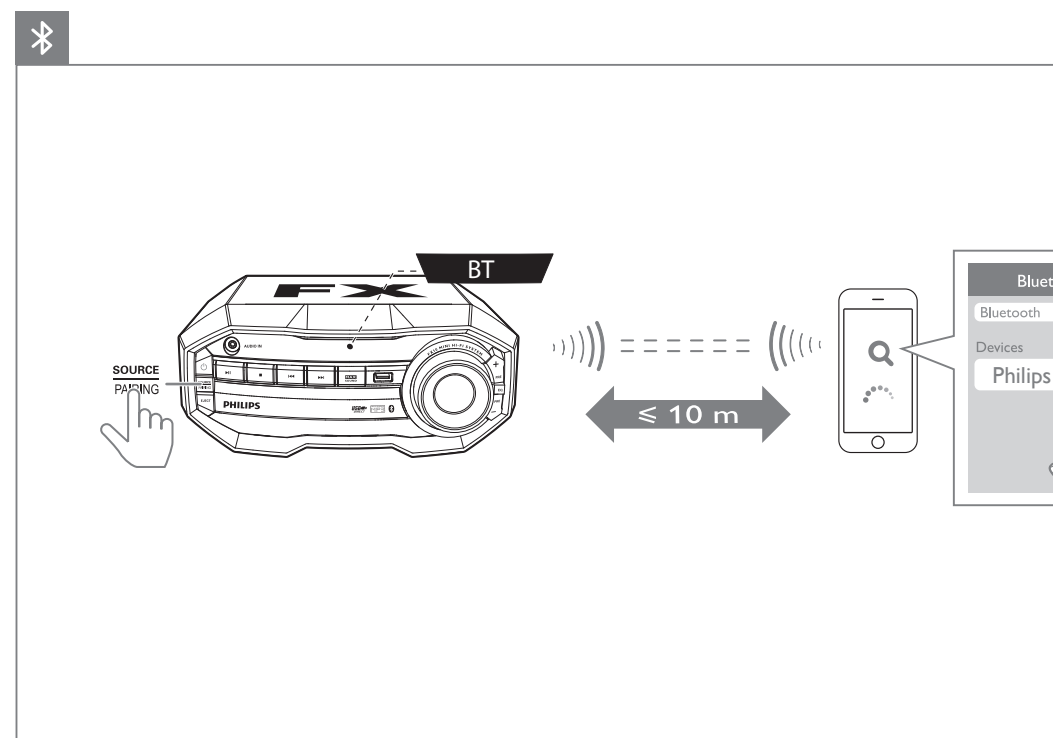
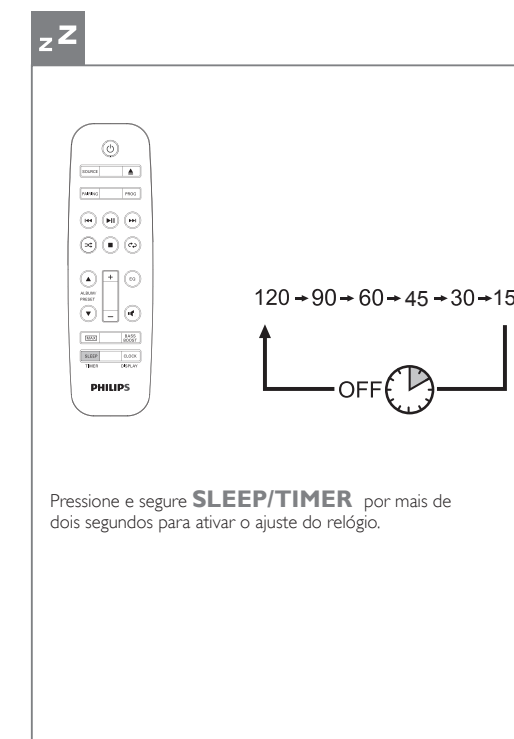
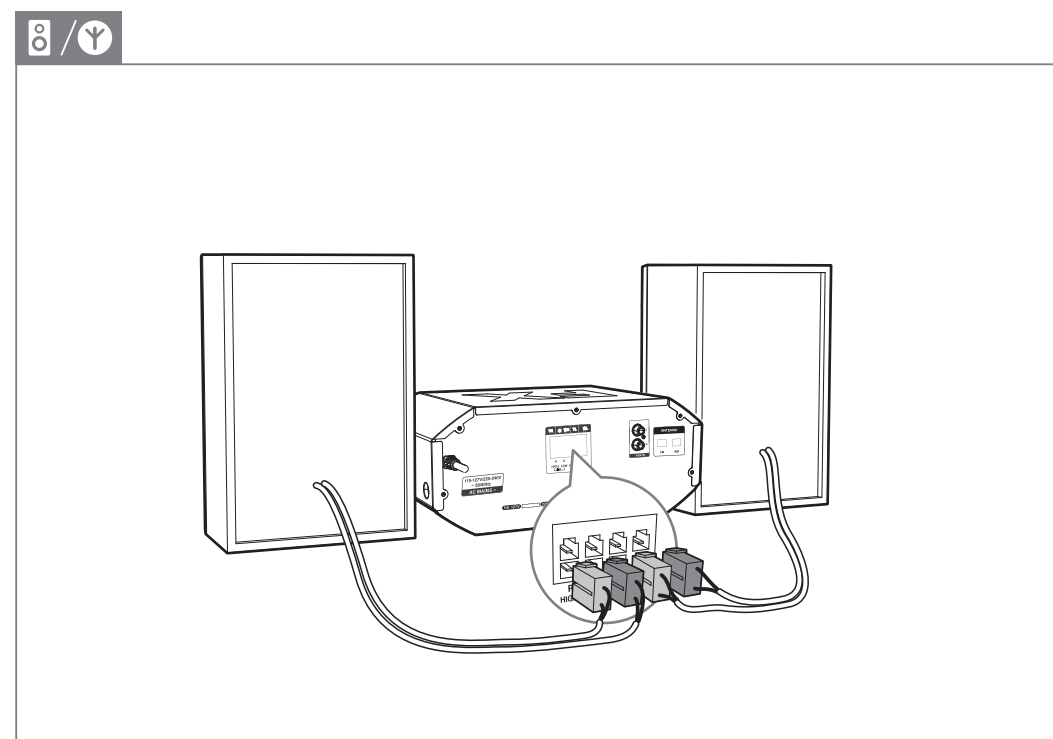
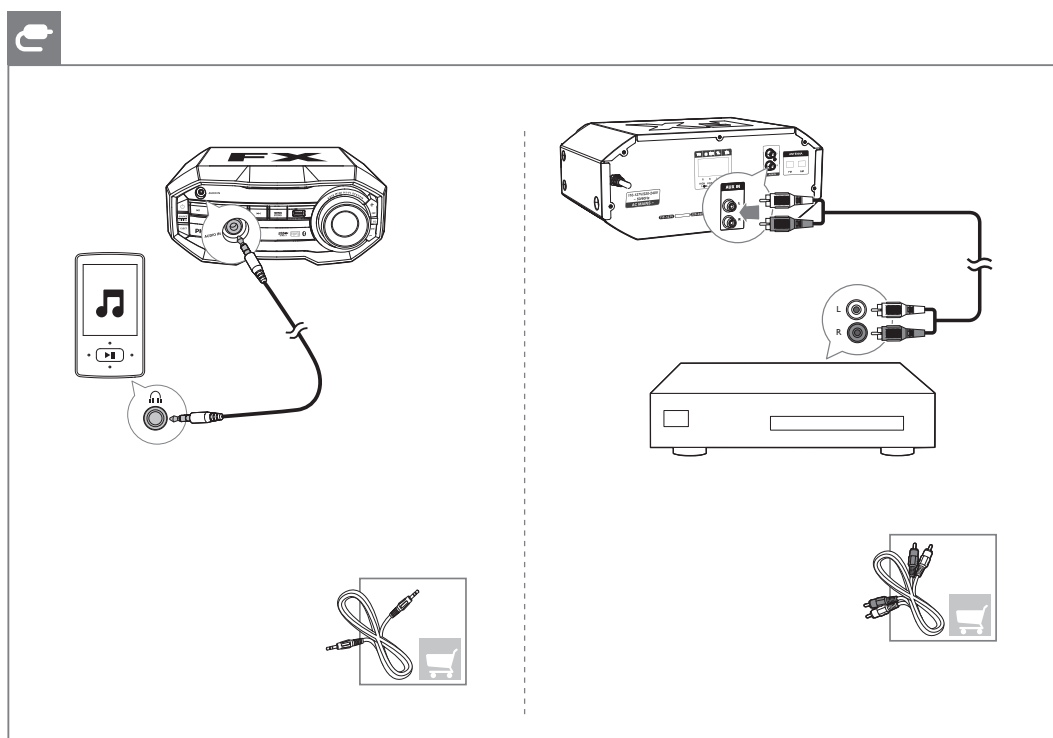
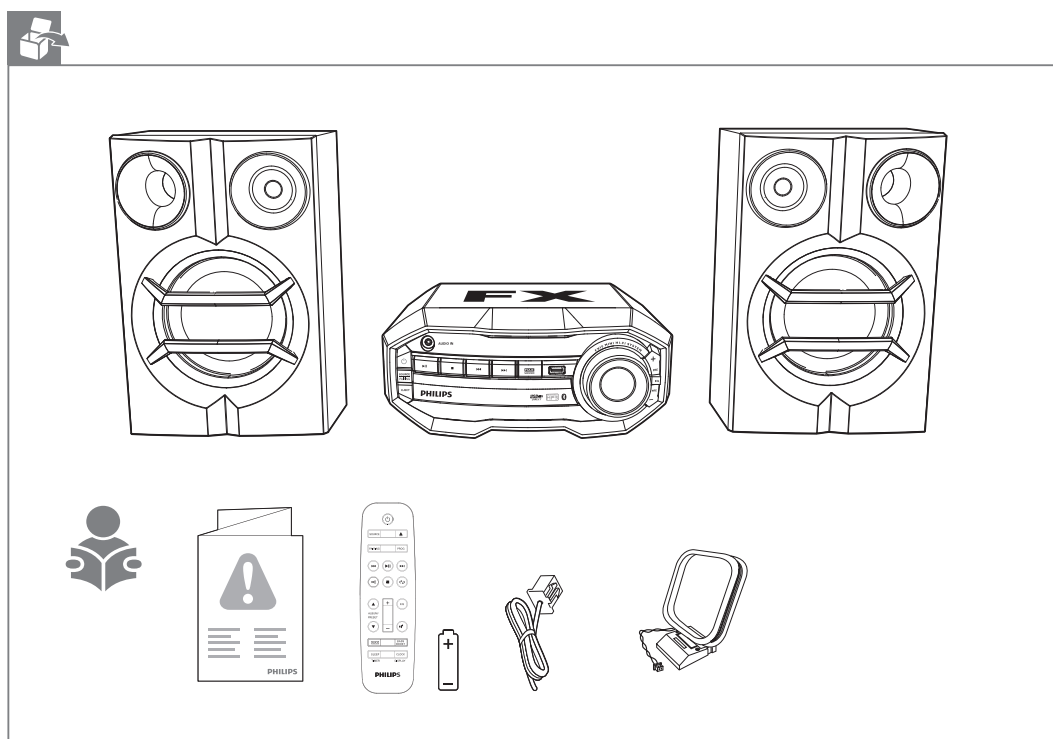

Conectar

- Pressione **SOURCE** repetidamente para selecionar a fonte Bluetooth.
 - **BT** (Bluetooth) é exibido na tela.
- Ative o Bluetooth em seu dispositivo móvel.
- Procure dispositivos Bluetooth que podem ser pareados, então, selecione **Philips FX10** para iniciar o pareamento e a conexão.
 - Após o pareamento e a conexão bem sucedida, **BT CONNECTED** (Bluetooth conectado) é exibido na tela uma vez.
- Toca música em seu dispositivo com Bluetooth por meio da unidade.
 - Dica: se você não conseguir encontrar **Philips FX10** para o pareamento, pressione e mantenha pressionado **PAIRING** por três segundos para entrar no modo de pareamento.

