

# Always there to help you

Register your product and get support at  
[www.philips.com/welcome](http://www.philips.com/welcome)

CEM2101



## User manual

**PHILIPS**



# Contents

<b>1 Important</b>	2	<b>7 Adjust system settings</b>	15
Safety	2	Turn beep sound on/off	15
Notice	2	Turn demo mode on/off	15
		Dimmer	15
		Dance	16
		Reset	16
<b>2 Your car audio system</b>	4		
Introduction	4	<b>8 Additional information</b>	16
What's in the box	4	Detach the front panel	16
Overview of the main unit	5	Replace fuse	16
		Remove the unit	17
<b>3 Get started</b>	6		
Install the car audio	6	<b>9 Product information</b>	18
Turn on	9		
Select country/region	10	<b>10 Troubleshooting</b>	19
Set clock format	10		
Set clock	10	<b>11 Glossary</b>	20
<b>4 Listen to radio</b>	11		
Tune to a radio station	11		
Store radio stations in memory	11		
Tune to a preset station	11		
<b>5 Play audio files</b>	12		
Play a disc	12		
Play from USB	12		
Play options	12		
Connect external sound source	13		
<b>6 Adjust sound</b>	14		
Adjust volume	14		
Mute	14		
Turn Dynamic Bass Boost (DBB) on/off	14		
Turn MAX sound on/off	14		
Select preset equalizer	14		
Switch music listening zone	14		
Other sound settings	15		

# 1 Important

## Safety

- Read and understand all instructions before you use your apparatus. If damage is caused by failure to follow instructions, the warranty does not apply.
- This apparatus is designed for negative ground (earth) 12 V DC operation only.
- To ensure safe driving, adjust the volume to a safe and comfortable level.
- Improper fuses can cause damage or fire. When you need to change the fuse, consult a professional.
- Use only the supplied mounting hardware for a safe and secure installation.
- To avoid short circuit, do not expose the apparatus, remote control or remote control batteries to rain or water.
- Never insert objects into the ventilation slots or other openings on the apparatus.
- Clean the apparatus and frame with a soft, damp cloth. Never use substances such as alcohol, chemicals or household cleaners on the apparatus.
- Never place any objects other than discs into the apparatus.
- Never use solvents such as benzene, thinner, cleaners available commercially, or anti-static sprays intended for discs.
- Visible and invisible laser radiation when open. Avoid exposure to beam.
- Risk of damage to the apparatus screen! Never touch, push, rub or strike the screen with any object.

### Caution

- Use of controls or adjustments or performance of procedures other than herein may result in hazardous radiation exposure or other unsafe operation.

- The apparatus shall not be exposed to dripping or splashing.
- Do not place any sources of danger on the apparatus (e.g. liquid filled objects, lighted candles).

## Notice

Any changes or modifications made to this device that are not expressly approved by Philips Consumer Lifestyle may void the user's authority to operate the equipment.

## Recycling



Your product is designed and manufactured with high quality materials and components, which can be recycled and reused.

When you see the crossed-out wheel bin symbol attached to a product, it means the product is covered by the European Directive 2002/96/EC:



Never dispose of your product with other household waste. Please inform yourself about the local rules on the separate collection of electrical and electronic products. The correct disposal of your old product helps prevent potentially negative consequences on the environment and human health.

### Environmental information

All unnecessary packaging has been omitted. We have tried to make the packaging easy to separate into three materials: cardboard (box), polystyrene foam (buffer) and polyethylene (bags, protective foam sheet.)

Your system consists of materials which can be recycled and reused if disassembled by a specialized company. Please observe the

local regulations regarding the disposal of packaging materials, exhausted batteries and old equipment.



The making of unauthorized copies of copy-protected material, including computer programs, files, broadcasts and sound recordings, may be an infringement of copyrights and constitute a criminal offence. This equipment should not be used for such purposes.



Windows Media and the Windows logo are trademarks, or registered trademarks of Microsoft Corporation in the United States and/or other countries.

**This apparatus includes this label:**



2013 © Koninklijke Philips Electronics N.V. All rights reserved.

Specifications are subject to change without notice. Trademarks are the property of Koninklijke Philips Electronics N.V. or their respective owners. Philips reserves the right to change products at any time without being obliged to adjust earlier supplies accordingly.

## 2 Your car audio system

Congratulations on your purchase, and welcome to Philips! To fully benefit from the support that Philips offers, register your product at [www.philips.com/welcome](http://www.philips.com/welcome).

### Introduction

With the in-car audio system, you can enjoy your drive while listening to:

- FM or AM (MW) radio
- Audio from CD or MP3 disc
- Audio from USB devices
- Audio from other external devices

The unit supports the following media format:



### What's in the box

Check and identify the contents of your package:

- ① Main unit (with a sleeve)
- ② Front panel
- ③ Trim plate
- ④ Carrying case for front panel
- ⑤ Rubber cushion
- ⑥ Screw x 1 pc
- ⑦ Disassembly tools x 2 pcs
- ⑧ User manual
- ⑨ ISO male connector

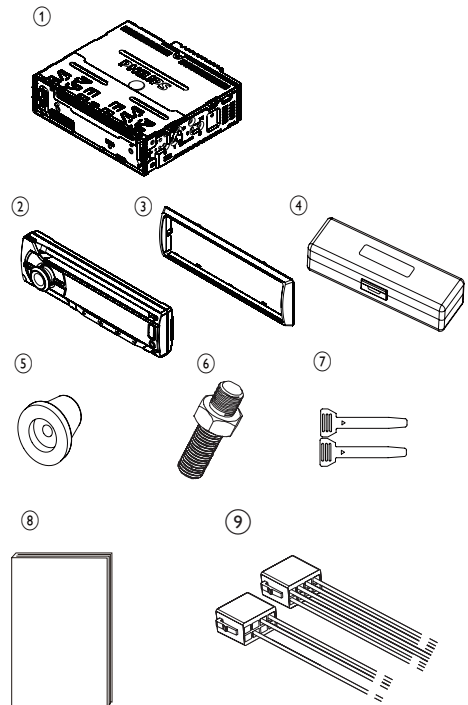

## Overview of the main unit

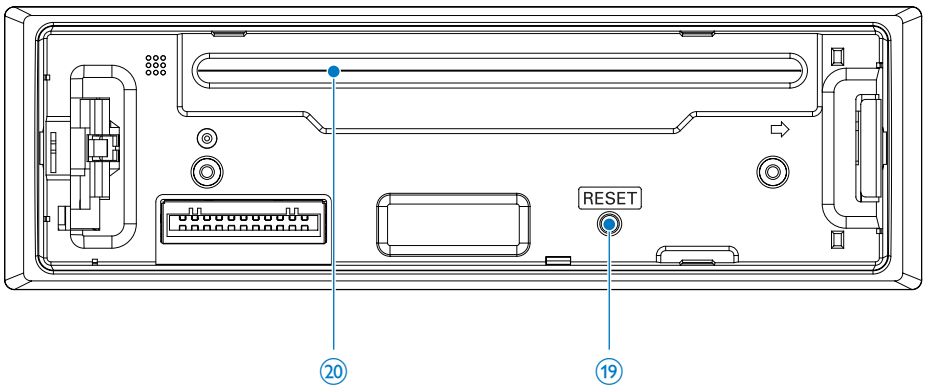
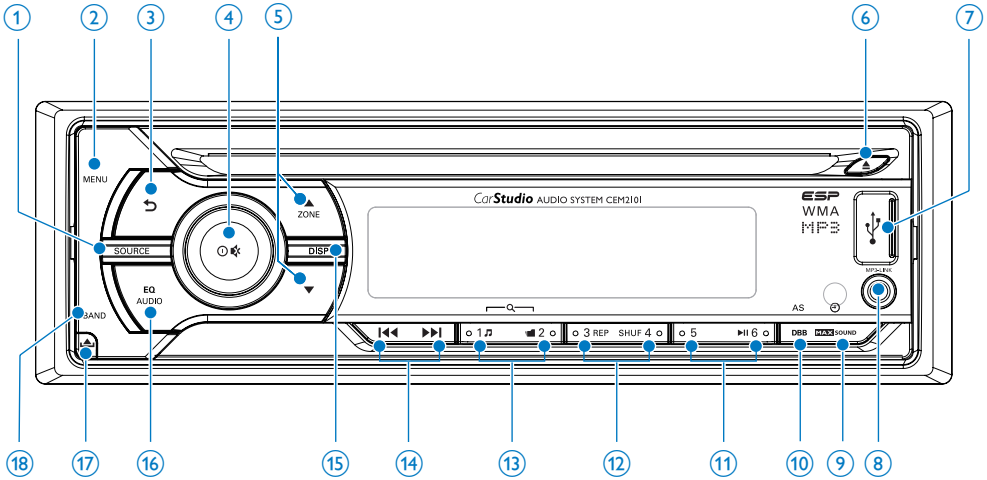

### ① SOURCE

- Select audio source.

### ② MENU

- Access system menu.

### ③ ↶

- Return to previous menu.

### ④ ⏻ / 🔊

- Turn the unit on or off.
- Confirm selection.
- Mute or unmute sound.
- Rotate to adjust volume.

### ⑤ ZONE ▲ / ▼

- Select tuner band.
- Select MP3/WMA folder.
- Switch music listening zone.

### ⑥ ▲

- Eject disc.

### ⑦ ⏏

- USB socket.

### ⑧ MP3 LINK

- Connect external audio device.

## 3 Get started

- 9 **MAX SOUND**
  - Turn on or off Maximizing volume.
  - View clock.
- 10 **DBB**
  - Turn on or off Dynamic Bass Boost (DBB) sound.
  - Access to tuner auto store.
- 11 **▶||**
  - Select preset radio station No.6.
  - Start play.
  - Pause or resume play.
- 12 **REP / SHUF**
  - Select preset radio station No.3/4.
  - Access to repeat play.
  - Access to shuffle play.
- 13 **♪ / 📁**
  - Select preset radio station No.1/2.
  - Search for track/folder.
- 14 **⏮ / ⏭**
  - Tune for radio station.
  - Skip/search for track.
  - Fast backward/forward playback.
- 15 **DISP**
  - Display current status.
  - Select the dimmer high or low.
- 16 **EQ / AUDIO**
  - Select equalizer (EQ) setting.
  - Access audio setting menu.
- 17 **🔒**
  - Unlock the panel.
- 18 **BAND**
  - Select tuner band.
- 19 **RESET**
  - Restore default settings.
- 20 **Disc slot**



### Caution

- Use the controls only as stated in this user manual.

Always follow the instructions in this chapter in sequence.

If you contact Philips, you will be asked for the model and serial number of your apparatus. The model number and serial number are on the bottom of your apparatus. Write the numbers here:

Model No. \_\_\_\_\_

Serial No. \_\_\_\_\_

---

## Install the car audio

These instructions are for a typical installation. However, if your car has different requirements, make the corresponding adjustment. If you have any questions regarding installation kits, consult your Philips car audio dealer.



### Caution

- This unit is designed for negative ground (earth) 12V DC operation only.
- Always install this unit in the car dashboard. Other locations can be dangerous as the rear of the unit heats up during use.
- To avoid short-circuit: before you connect, ensure that the ignition is off.
- Ensure that you connect the yellow and red power supply leads after all other leads are connected.
- Ensure that all loose leads are insulated with electrical tape.
- Ensure that the leads do not get caught under screws or in parts that will move (e.g. seat rail).
- Ensure that all ground (earth) leads are run to a common ground (earth) point.
- Use only the supplied mounting hardware for a safe and secure installation.
- Improper fuses can cause damage or fire. When you need to change the fuse, consult a professional.



### Note on the power supply lead (yellow)

- When you connect other devices to this apparatus, ensure that the rating of the car circuit is higher than the total fuse value of all the connected devices.

### Notes on speaker connection

- Never connect speaker wires to the metal body or chassis of the car.
- Never connect speaker wires with stripes to one another.

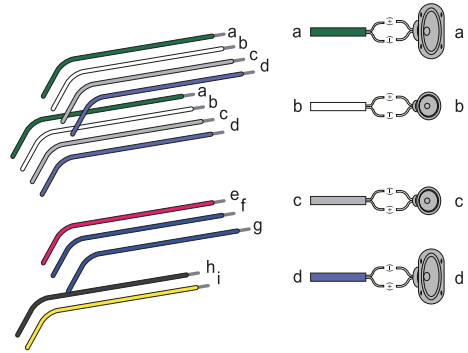

## Connection: for cars with ISO connectors

### Caution

- Ensure that all loose leads are insulated with electrical tape.

### Note

- Consult a professional to connect CEM2101 as instructed below.

- Connect the supplied male connector to the unit.

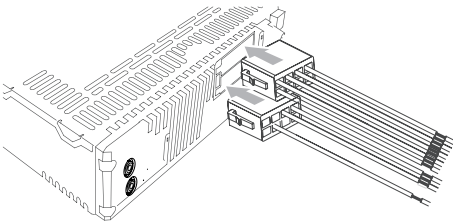

- Check the car's wiring carefully and connect them to the the supplied male connector.

### Note

- Risk of danger! Please consult a professional to perform the below steps!

a	Green/black strip	Left speaker (Rear)
b	White/black strip	Left speaker (Front)
c	Gray/black strip	Right speaker (Front)
d	Purple/black strip	Right speaker (Rear)
e	Red	Ignition key +12V DC when ON/ACC
f	Blue	Motor/electric antenna relay control lead
g	Blue/white	Amplifier relay control lead
h	Black	Ground
i	Yellow	To the +12V car battery which is energized at all times

- Connect the antenna and amplifier as illustrated, if applicable.

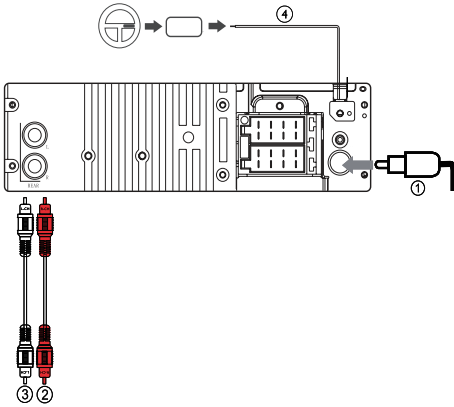

Connector	Connect to
1 ANTENNA	Antenna
2 REAR LINE OUT R (Socket)	Rear right speaker
3 REAR LINE OUT L (Socket)	Rear left speaker
4 OE REMOTE (Purple)	OE Remote

#### Tip

- The pin arrangement for the ISO connectors depends on the type of vehicle you drive. Be sure to make proper connections to prevent damage to the unit.

## Mount into the dashboard

- If the car does not have an on-board drive or navigation computer, disconnect the negative terminal of the car battery.
  - If you disconnect the car battery in a car that has an on-board drive or navigation computer, the computer may lose its memory.
  - If the car battery is not disconnected, to avoid short-circuit, ensure that the bare wires do not touch each other.
- Ensure that car dashboard opening is within these measurements:

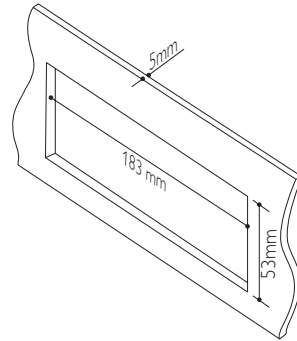

- Remove the mounting sleeve with the supplied disassembly tools.

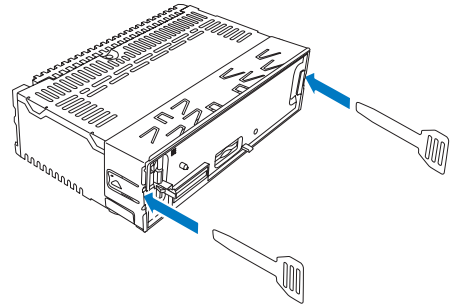

- Install the sleeve into the dashboard and bend the tabs outward to fix the sleeve.

#### Note

- If the unit is not fixed by sleeve but by the supplied screws, skip this step.

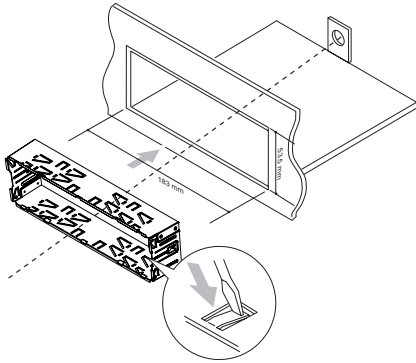

- 5 Place the supplied rubber cushion over the end of the mounting bolt.

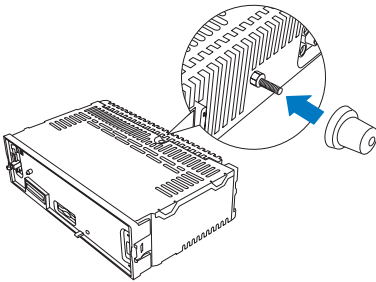

- 6 Slide the unit into the dashboard until you hear a click sound.

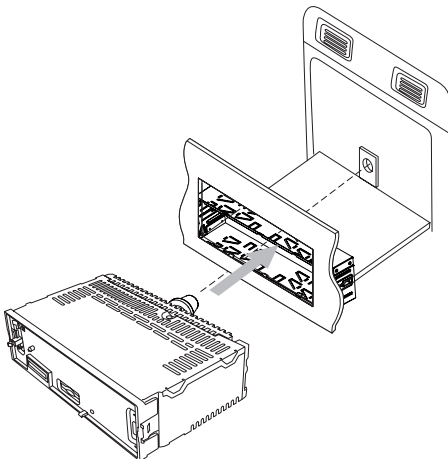

- 7 Reconnect the negative terminal of the car battery.

## Attach the front panel

- 1 Attach the trim plate.
- 2 Insert the right side of the panel in the chassis until it is correctly engaged.
- 3 Press the left side of the panel until the mechanism locks it into place.

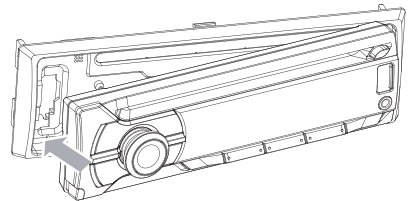
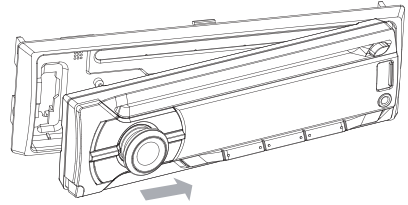

## Turn on

To turn on the unit,

- Press  $\odot$ .

To turn off the unit,

- press and hold  $\odot$  until the unit is turned off.

---

## Select country/region



### Note

- Select correct country/region for this unit, otherwise the unit can not work properly.

- 1 Press **⊕** to turn the unit on.  
↳ **[SELECT OPERATING REGION]** is displayed.
- 2 Rotate **⊕** to select an option:
  - **[USA]** (United States)
  - **[LATIN]** (Latin America)
  - **[EUROPE]** (Western Europe)
  - **[RUS]** (Russia)
  - **[M-EAST]** (Middle East)
  - **[ASIA]** (Pacific)
  - **[JAP]** (Japan)
  - **[AUST]** (Australia)
- 3 Press **⊕** to confirm.

---

## View clock

In any mode, press and hold **MAX SOUND** until the clock is displayed.

- Press any key to cancel the clock display.

---

## Set clock format

- 1 Press **MENU**.
- 2 Press **▲** or **▼** repeatedly until **[CLOCK FORMAT]** is displayed.
- 3 Rotate **⊕** to select a setting:
  - **[CLOCK 12H]**
  - **[CLOCK 24H]**

---

## Set clock

- 1 Press **MENU** repeatedly until current time is flashed.
- 2 Rotate **⊕** to set hour.
- 3 Press **⊕** to confirm.
- 4 Rotate **⊕** to set minute.
- 5 Press **⊕** to confirm.

## 4 Listen to radio

---

### Tune to a radio station

- 1 Press **SOURCE** repeatedly to select radio mode.
- 2 Press **BAND** or ▲ / ▼ repeatedly to select band: **[FM1]**, **[FM2]**, **[FM3]**, **[AM1]**, or **[AM2]**.
- 3 Press and hold **◀◀** or **▶▶** until the frequency digit is flashed.
- 4 Press **◀◀** or **▶▶** to tune to a radio station manually.
  - ↳ The radio station is broadcast.
  - To search for a radio station automatically, press **◀◀** or **▶▶**.

### Select tuner sensitivity

To receive more radio stations or only stations with strong signal, you can adjust the tuner sensitivity.

- 1 Press **MENU** repeatedly until **[LOCAL]** is displayed.
- 2 Rotate **⊖** to select a setting:
  - **[LOCAL ON]** (local on): only stations with strong signal can be broadcast.
  - **[LOCAL OFF]** (local off): stations with strong and weak signals can be broadcast.

### Store radio stations in memory

You can store up to 6 stations in each band.

---

### Store stations automatically

- 1 In Radio mode, press and hold **DBB** until **[STORE - - -]** is displayed.
- 2 Press **⊖** to confirm.
  - ↳ The six strongest stations of the selected band are saved in preset channel automatically.

---

### Store stations manually

- 1 Tune to a station that you want to store. (see 'Tune to a radio station' on page 11)
- 2 Press a numeric button for 3 seconds.
  - ↳ The station is saved in the selected channel.

---

### Tune to a preset station

- 1 Press **BAND** to select band.
- 2 Press a numeric key to select a preset station.

# 5 Play audio files

## Note

- Ensure that the disc or device contains playable files.

## Play a disc

### Note

- You cannot play CDs encoded with copyright protection technologies.

You can play commercially available audio CDs and these discs:

- CD-Recordables (CD-R)
- CD-Re-writables (CD-RW)
- MP3 CDs
- WMA CDs

### Note

- Ensure that the disc contains playable content.

Insert a CD with the printed side facing up.

- ↳ Play starts automatically.
- To pause CD play, press ►||.
- To resume CD play, press ►|| again.
- To skip to the previous/next track, press ◀◀ or ▶▶.
- To search backward/forward rapidly within the current track, press ◀◀ or ▶▶ for three seconds.

## Remove the CD

To take out the CD, press ▲ on the front panel.

## Tip

- If the disc is blocked in the disc compartment, press and hold ▲ until the disc comes out.

## Play from USB

### Note

- Ensure that the USB device contains playable music.

## Insert the USB device

- 1 Slide the USB socket cover marked  to the left.
- 2 Insert the USB device into the USB socket. ↳ The unit starts playing from the USB device automatically.

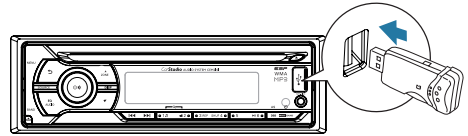

## Remove the USB device

- 1 Press ○ to turn off the unit.
- 2 Remove the USB device.

## Play options

### Search for an MP3/WMA track

#### Search within the current folder

- 1 Press ♪.  
↳ The name of the current track is displayed.
- 2 Rotate ○ to select another track in current folder.
- 3 Press ○ to confirm.

#### Search in other folder

- 1 Press .  
↳ The name of the current folder is displayed.

- 2 Rotate  $\odot$  to navigate through all folders.
- 3 Press  $\odot$  to access the selected folder.
  - ↳ The unit starts playing the first song from the selected folder automatically.



Tip

- To go back to upper level of a folder, press  $\leftarrow$ .

---

## View play information

During playing, press **DISP** repeatedly to view:

- Track number and elapsed play time
- Folder
- File
- Album
- Artist
- Title

---

## Repeat play

- 1 During play, press **REP**.
  - ↳ **[REPEAT]** is displayed.
- 2 Rotate  $\odot$  to select a setting:
  - **[REP TRK]** (repeat one track): play current track repeatedly.
  - **[REP FLD]** (repeat a folder): play all tracks in the current folder repeatedly.
  - **[REP ALL]** (repeat all tracks): play all tracks repeatedly.

---

## Shuffle play

You can play the tracks in random order:

- 1 During play, press **SHUF**.
  - ↳ **[SHUFFLE]** is displayed.
- 2 Rotate  $\odot$  to select a setting:
  - **[SHUF FLD]**: start random play for all tracks in the current folder.
  - **[SHUF ALL]**: start random play for all tracks.

- **[SHUF OFF]**: cancel shuffle play.

---

## Connect external sound source

- 1 Connect the external sound source to **MP3 LINK** socket with a 3.5 mm cable.
- 2 Press **SOURCE** repeatedly until **[MP3 LINK]** is displayed.
- 3 Operate the external component (refer to the instructions supplied with the external component).

# 6 Adjust sound

---

## Adjust volume

Turn  $\odot$  clockwise/counterclockwise to increase/decrease volume.

---

## Mute

You can turn off the sound of your audio.

During play, press  $\odot$ .

- To resume sound, press  $\odot$  again.

---

## Turn Dynamic Bass Boost (DBB) on/off

- 1 Press **DBB** and the current setting is displayed:
  - ↳ **[DBB ON]**: Dynamic Bass Boost (DBB) function is on.
  - ↳ **[DBB OFF]**: Dynamic Bass Boost (DBB) function is off.
- 2 Press **DBB** again to change the DBB setting.

---

## Turn MAX sound on/off

- 1 Press **MAX SOUND**.
  - ↳ The current setting displays
    - **[MAX ON]**: maximum sound (MAX sound) function is on.
    - **[MAX OFF]**: maximum sound (MAX sound) function is off.
- 2 Press **MAX SOUND** again to select an option.

---

## Select preset equalizer

- 1 Press **EQ / AUDIO**.
  - ↳ Current Equalizer setting is displayed.
- 2 Press **EQ / AUDIO** again to select a preset EQ setting:
  - **[OPTIMAL]** (optimal)
  - **[FLAT]** (flat)
  - **[POP]** (pop)
  - **[USER]** (user)
  - **[TECHNO]** (techno)
  - **[ROCK]** (rock)
  - **[CLASSIC]** (classic)
  - **[JAZZ]** (jazz)

---

## Switch music listening zone

Philips' innovative Zone technology enables driver or passengers to enjoy music with the best speakers balance and experience more vivid spacial effect as the artist is intended to create. You can switch the music listening zone from driver to passengers for the best speaker sound settings in car.

- 1 Press **ZONE**.
  - ↳ The current setting is displayed.
- 2 Rotate  $\blacktriangle$  /  $\blacktriangledown$  to select a setting:
  - **[ALL]** (All)
  - **[FRONT-L]** (Front left)
  - **[FRONT-R]** (Front right)
  - **[FRONT]** (Front)



---

## Other sound settings

You can also adjust the preset **EQ / AUDIO** settings.

- 1 Press **EQ / AUDIO** for 3 seconds.
- 2 Press **▲** or **▼** repeatedly to select the item to be adjusted:
  - **[BAS]** (bass) range: -7 to +7.
  - **[TRE]** (treble) range: -7 to +7.
  - **[BAL]** (balance) range: 12L to 12R. (L=left speaker, R=right speaker)
  - **[FAD]** (fader) range: 12R to 12F. (R=rear speaker, F=front speaker)
- 3 Rotate **⊕** to select a value.

## 7 Adjust system settings

---

### Turn beep sound on/off

Each time you press a button, the unit beeps. You can turn this beep sound on or off.

- 1 Press **MENU**.
- 2 Press **▲** or **▼** repeatedly until **[BEEP]** is displayed.
- 3 Rotate **⊕** to select a setting:
  - **[BEEP ON]**: turn the beep sound on.
  - **[BEEP OFF]**: turn the beep sound off.

---

### Turn demo mode on/off

- 1 Press **MENU**.
- 2 Press **▲** or **▼** repeatedly until **[DEMO]** is displayed.
  - ↳ The screen shows current demo mode setting.
- 3 Rotate **⊕** to select a setting:
  - **[DEMO ON]**: turn the demo mode on. When the unit is idle for more than 120 seconds, all functions are displayed.
  - **[DEMO OFF]**: turn the demo mode off.

---

### Dimmer

- 1 Press **MENU**.
- 2 Press **▲** or **▼** repeatedly until **[DIMMER]** is displayed.

- 3 Rotate  to select a setting:
  - [DIMM HIGH] (dimmer high)
  - [DIMM LOW] (dimmer low)

---

## Dance

You can turn on or off the spectrum on the LCD display.

- 1 Press **MENU**.
- 2 Press **▲** or **▼** repeatedly until [DANCE] is displayed.
- 3 Rotate  to select a setting:
  - [DANCE ON]: turn the spectrum on.
  - [DANCE OFF]: turn the spectrum off.

---

## Reset

You can reset the unit to its default setting.

- 1 Detach the front panel.
- 2 Press the reset button by using a ball-point pen or a similar tool.
  - ↳ Preset adjustments such as preset channels and sound adjustments are erased.

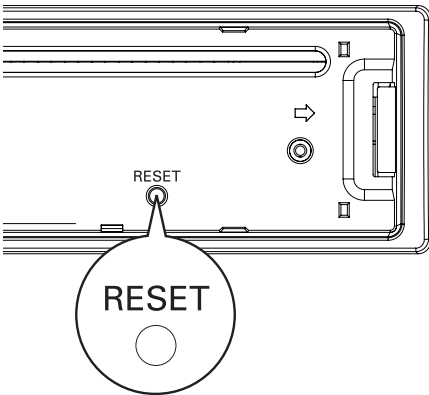

# 8 Additional information

---

## Detach the front panel

You can detach the front panel to deter theft.

- 1 Press  to release the panel.
- 2 Pull the panel towards you to disengage it from the chassis.

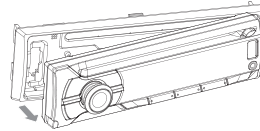
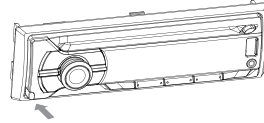

- 3 Store the panel in the supplied carrying case to protect it from dirt or damage.

---

## Replace fuse

If the fuse is damaged,

- 1 Check the electric connection.
- 2 Buy a fuse that matches the voltage of the damaged fuse.
- 3 Replace the fuse.

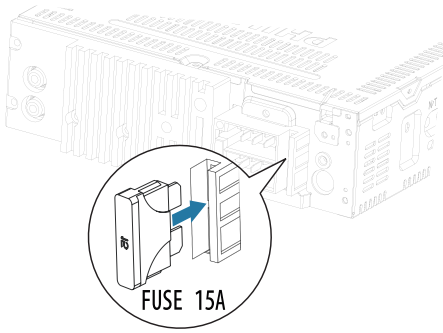

### ☰ Note

- If the new fuse gets damaged again, there may be an internal malfunction. Consult your Philips dealer.

---

## Remove the unit

You can remove the unit from the dashboard.

- 1 Detach the front panel.
- 2 Pull out the unit by using the disassembly tools.

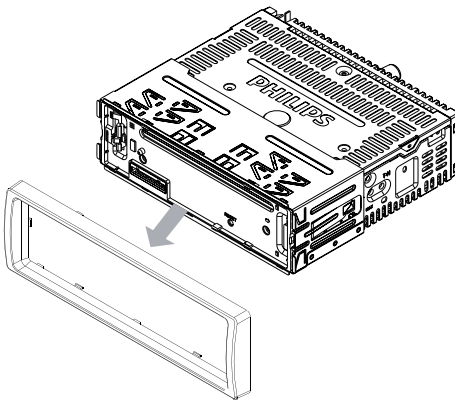

# 9 Product information



## Note

- Product information is subject to change without prior notice.

Power supply	12V DC (11 V - 16 V), negative ground
Fuse	15 A
Suitable speaker impedance	4 - 8 $\Omega$
Maximum power output	50 W x 4
Continuous power output	21 W x 4 RMS (4 $\Omega$ 10% T.H.D.)
Pre-Amp output voltage	2.5V
Aux-in level	500 mV
Dimensions (W x H x D)	181.5 x 52 x 191.4 mm
Weight	1.47 kg

## Radio

Frequency range - FM	87.5 - 108.0 MHz
Frequency range - AM(MW)	522 - 1620 KHz (9 kHz) 530 - 1710 kHz (10 kHz)
Usable sensitivity - FM	8 $\mu$ V
Usable sensitivity - AM(MW)	30 $\mu$ V

## Compatible USB devices:

- USB flash memory: USB 1.1 host with interface reading all speed support (1.1, 2.0)
- USB flash players: USB 1.1 host with interface reading all speed support (1.1, 2.0)

## Supported formats:

- USB or memory file format: FAT12, FAT16, FAT32
- MP3 bit rate (data rate): 32-320 Kbps and variable bit rate
- WMA V4,V7,V8,V9 (L1, L2)
- MP3 sampling frequencies: 8-48 kHz
- MP3 Bit-rates: 8~320 (kbps), variable bit rates
- WMA sampling frequencies: 32 kHz, 44.1 kHz, 48 kHz
- WMA Bit-rates: 32~192 (kbps), variable bit rates
- Directory nesting up to a maximum of 8 levels
- Number of albums/folders: CD maximum 99, USB or memory maximum 99
- Number of tracks/titles: CD maximum 999 (depending on number of album), USB or memory maximum 999
- ID3 tag v2.0 or later

### Unsupported formats:

- Empty albums: an empty album is an album that does not contain MP3/WMA files, and is not be shown in the display.
- Unsupported file formats are skipped. For example, Word documents (.doc) or MP3 files with extension .dlf are ignored and not played.
- AAC, WAV, PCM audio files
- DRM protected WMA files (.wav, .m4a, .m4p, .mp4, .aac)
- WMA files in Lossless format

## 10 Troubleshooting



### Caution

- Never remove the casing of this apparatus.

To keep the warranty valid, never try to repair the system yourself.

If you encounter problems when using this apparatus, check the following points before requesting service. If the problem remains unsolved, go to the Philips web site ([www.philips.com/support](http://www.philips.com/support)). When you contact Philips, ensure that your apparatus is nearby and the model number and serial number are available.

### No power or no sound.

- Car engine is not on. Turn the car engine on.
- Cable is not correctly connected. Check connections.
- Fuse is burnt. Replace fuse.
- Volume is too low. Adjust volume.
- If the above solutions cannot help, press **RESET** button.
- Ensure that the track played is of a compatible format.

### Noise in broadcasts.

- Signals are too weak. Select other stations with stronger signals.
- Check the connection of the car antenna.
- Change broadcast from Stereo to mono.

### Cannot play disc

- Ensure that the disc label is inserted with the printed side facing up.
- Wipe the disc with fibre cleaning cloth from the centre to the edge in a straight line.
- This disc may be defective. Play another disc.
- Ensure that the CD is a finalised CD/CD-R/CD-RW.

- Ensure that the CD is not encoded with copyright protection technologies.

#### The CD skips tracks

- Ensure that the CD is not damaged or dirty.
- Ensure that random mode is deactivated.

#### Disc cannot be ejected

- Press and hold ▲.

#### Preset stations lost.

- Battery cable is not correctly connected. Connect the battery cable to the terminal that is always live.

#### Display show ERR-12

- USB data error. Check the USB device.

# 11 Glossary

---

## M

### MP3

A file format with a sound data compression system. MP3 is the abbreviation of Motion Picture Experts Group 1 (or MPEG-1) Audio Layer 3. With the MP3 format, one CD-R or CD-RW can contain about 10 times more data than a regular CD.

---

## W

### WMA (Windows Media Audio)

An audio format owned by Microsoft, is a part of Microsoft Windows Media technology. Includes Microsoft Digital Rights Management tools, Windows Media Video encoding technology, and Windows Media Audio encoding technology.





Specifications are subject to change without notice  
© 2013 Koninklijke Philips Electronics N.V.  
All rights reserved.

CEM2101\_55\_UM\_V1.0





# Always there to help you

Register your product and get support at  
[www.philips.com/welcome](http://www.philips.com/welcome)



CSP6910



# User manual

# PHILIPS



# Contents

---

<b>1</b>	<b>Important</b>	<b>4</b>
	Safety	4
	Notice	4

---

<b>2</b>	<b>Your car stereo speakers</b>	<b>5</b>
	Introduction	5
	What's in the box	5

---

<b>3</b>	<b>Installation</b>	<b>5</b>
	Option 1: Mount on door (front or rear)	5
	Option 2: Mount on rear tray	7

---

<b>4</b>	<b>Product information</b>	<b>7</b>
----------	----------------------------	----------

---

<b>5</b>	<b>Troubleshooting</b>	<b>8</b>
----------	------------------------	----------

---

# 1 Important

---

## Safety

- Read and understand all instructions before you use the apparatus. If damage is caused by failure to follow instructions, the warranty does not apply.
- Use only the supplied mounting hardware for a safe and secure installation.
- Do not continuously use the speaker system beyond the peak power handling capacity.
- Keep credit cards, watches, recorded tapes etc. with magnetic coding away from the speaker system to prevent damage caused by the magnets in the speakers.
- Clean the apparatus with soft, damp cloth. Never use substances such as alcohol, chemicals or household cleaners on the apparatus.

---

## Notice

### Environmental information

All unnecessary packaging has been omitted. We have tried to make the packaging easy to separate into three materials: cardboard (box), polystyrene foam (buffer) and polyethylene (bags, protective foam sheet.)

Your system consists of materials which can be recycled and reused if disassembled by a specialized company. Please observe the local regulations regarding the disposal of packaging materials, exhausted batteries and old equipment.

Any changes or modifications made to this device that are not expressly approved by Philips Consumer Lifestyle may void the user's authority to operate the equipment.

2013 © Koninklijke Philips Electronics N.V. All rights reserved.

Specifications are subject to change without notice. Trademarks are the property of Koninklijke Philips Electronics N.V. or their respective owners. Philips reserves the right to change products at any time without being obliged to adjust earlier supplies accordingly.

## 2 Your car stereo speakers

Congratulations on your purchase, and welcome to Philips! To fully benefit from the support that Philips offers, register your product at [www.philips.com/welcome](http://www.philips.com/welcome).

### Introduction

With the speakers, you can enjoy high power music with vivid sound.

### What's in the box

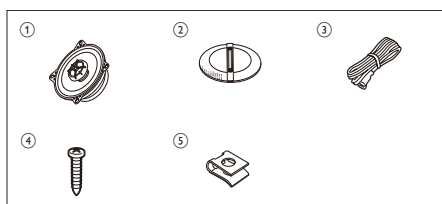

Check and identify the contents of your package:

- ① Speakers (x2)
- ② Grille net + Frame (x2)
- ③ Speaker wire (x2)
- ④ Screw (x8)
- ⑤ Shrapnel (x8)

## 3 Installation

A depth of at least 46mm is required to mount the speaker. Measure the depth of the area where you are to mount the speaker; and ensure that the speaker does not obstruct any other components of the car.

### Option 1: Mount on door (front or rear)

You can mount the speakers on the front/rear door of your car.

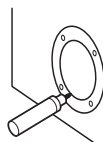

#### Nota

- Make sure that nothing obstructs around the mounting location of the door.
- A hole for mounting may already be cut out of the inner panel of the door (front or rear). In this case, you need to modify the board only.
- Ensure that the speaker terminals, frame or magnet do not interfere with any inner parts, such as the window mechanism in the door (when you open or close the window), etc. Also ensure that the speaker grille does not touch any inner fittings, such as the window cranks, door handles, arm rests etc.

- 1 Turn off the car ignition key.
  - If the power is on, the click noise generated by the connection may damage the speakers.
- 2 Cut out the mounting template from the packing box.
- 3 Paste the template on the location selected for mounting the speaker.

4 Mark the cut-off hole and the 4 bolt holes.

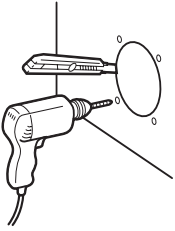

5 Cut out the marked area and drill the bolt holes.

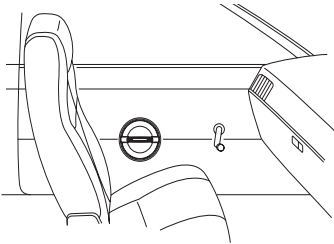

6 Remove the grille net.

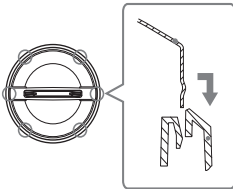

7 Strip the speaker wires and connect them to the amplifier:

- Black wire: connect to “-” (negative) terminal
- Black (white lined): connect to “+” (positive) terminal

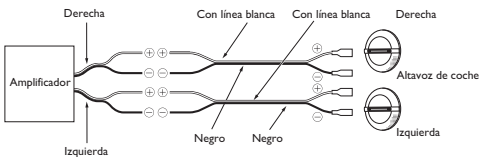

### Note

- Match the “left”, “right”, “+” and “-” terminals correctly. Revised polarity may degrade sound quality.
- Two 4-ohm speakers, wired in stereo, present a 8 ohm load to each channel of the amplifier. Most two channel amplifiers work well in this configuration. However, if two 4-ohm speakers, wired in parallel to a bridged two-channel amplifier, present a 2-ohm mono load to the amplifier. Most 2-channel amplifiers do not support 2-ohm mono operation! Amplifier damage may result!

8 Mount on the speaker as shown below.

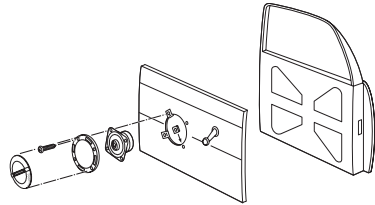

9 Press and insert the edges of the grille net.

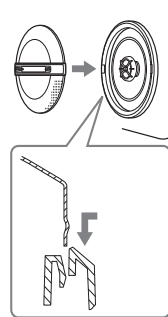

### Tip

- The speaker grille can be mounted without the grille net, if you like.

## Option 2: Mount on rear tray

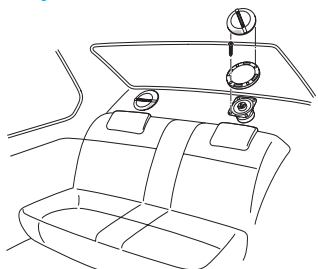

You can also mount the speakers into the surface of the rear tray.

Follow the steps in section “Option 1: Mount in door” to mount the speakers into the rear tray:

# 4 Product information

### Note

- Product information is subject to change without prior notice.

<b>Model</b>	<b>CSP6910</b>
<b>Speaker type</b>	16x24cm, 3-way triaxial speaker
<b>RMS power (Watts)</b>	50W
<b>Peak music power (Watts)</b>	300W
<b>Sensitivity (dB/W/m)</b>	90dB
<b>Frequency response (Hz)</b>	28-32kHz
<b>Impedance (ohms)</b>	4 ohms
<b>Magnet mass (Oz)</b>	12.6Oz
<b>Mounting depth (mm)</b>	78mm

# 5 Troubleshooting

To keep the warranty valid, never try to repair the system yourself.

If you encounter problems when using this apparatus, go to the Philips web site ([www.philips.com/welcome](http://www.philips.com/welcome)). When you contact Philips, ensure that the apparatus is nearby and the model number and serial number are available.







Specifications are subject to change without notice

© 2013 Koninklijke Philips Electronics N.V.

All rights reserved.

CSP6910\_UM\_55\_UM\_V3.0

