

Always there to help you

Register your product and get support at
www.philips.com/welcome

CE138



User manual

PHILIPS

Contents

1	Safety	2	9	Adjust sound	19
2	Your car audio system	3	10	Additional information	20
	Introduction	3		Reset the system	20
	What's in the box	3		Replace the fuse	20
	Overview of the system	4	11	Product Information	21
	Overview of the remote control	6	12	Troubleshooting	22
3	Install the car audio system	7	13	Notice	23
	Connect wires	7		Care of the environment	23
	Mount into the dashboard	8		Trademark notice	23
	Attach the front panel	9		Copyright	23
4	Get started	10	14	Glossary	24
	For the first time use	10			
	Set the time format	10			
	Set the clock	10			
	Select a source	10			
	Select a listening zone	10			
	Mute the button beep	11			
	Install/replace the remote control battery	11			
5	Listen to radio	12			
	Select a tuner region	12			
	Select a tuner sensitivity	12			
	Search for a radio station	12			
	Store radio stations in memory	12			
6	Play from a storage device	14			
	Control play	14			
	Switch tracks	14			
7	Play from an iPod/iPhone	16			
	Compatible iPod/iPhone models	16			
	Connect your iPod/iPhone	16			
	Control play	16			
	Charge your iPod/iPhone	17			
8	Listen to an external player	18			

1 Safety

Read and understand all instructions before you use this device. If damage is caused by failure to follow instructions, the warranty does not apply.

- Modification of the product could result in hazardous radiation of EMC or other unsafe operation.
- The device is designed for negative ground (earth) 12 V DC operation only.
- To ensure safe driving, adjust the volume to a safe and comfortable level.
- Improper fuses can cause damage or fire. When you need to change the fuse, consult a professional.
- Use only the supplied mounting hardware for a safe and secure installation.
- To avoid short circuits, do not expose the device to rain or water.
- The device shall not be exposed to dripping or splashing.
- Do not place any sources of danger on the device (e.g. liquid filled objects, lighted candles).
- Never insert objects into the ventilation slots or other openings on the device.
- Clean the device with soft, damp cloth. Never use substances such as alcohol, chemicals or household cleaners on the device.
- Risk of swallowing batteries! A coin type battery is bundled, which can be swallowed. Keep the battery out of reach of children at all times!

2 Your car audio system

Congratulations on your purchase, and welcome to Philips! To fully benefit from the support that Philips offers, register your product at www.philips.com/welcome.

Introduction

With this system, you can:

- enjoy audio from a USB storage device, SD/SDHC card, iPod/iPhone, and external player;
- charge your iPod/iPhone, and
- listen to radio stations.

You can enrich sound output with these sound effects:

- Dynamic bass boost (DBB)
- Digital sound control (DSC)

Playable media:

- USB storage device
 - Compatibility: USB 2.0, USB 1.1
 - Class support: MSC (Mass Storage Class)
 - Maximum capacity: 32 GB
- SD/SDHC card
 - Maximum capacity: 32 GB
- Files
 - File system: FAT16, FAT32
 - Maximum number of folders: 99
 - Maximum number of tracks/files: 999
 - Maximum level of directory: 8
 - .mp3 files
 - Sampling frequencies: 32 kHz, 44.1 kHz, 48 kHz
 - Bitrates: 8-320 kbps and variable bitrates
 - .wma files
 - Versions: V4, V7, V8, V9 (L1 and L2)
 - Sampling frequencies: 44.1 kHz, 48 kHz

Bitrates: 64-192 kbps and variable bitrates

- ID3 tag V2.0 or later
- **Unsupported files:**
AAC, WAV, and PCM files
DRM protected WMA files (.wav, .m4a, .m4p, .mp4, and .aac)
WMA files in lossless format

What's in the box



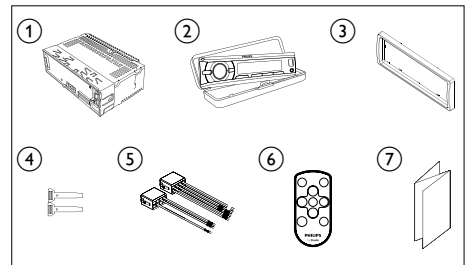

Check and identify the contents of the package:

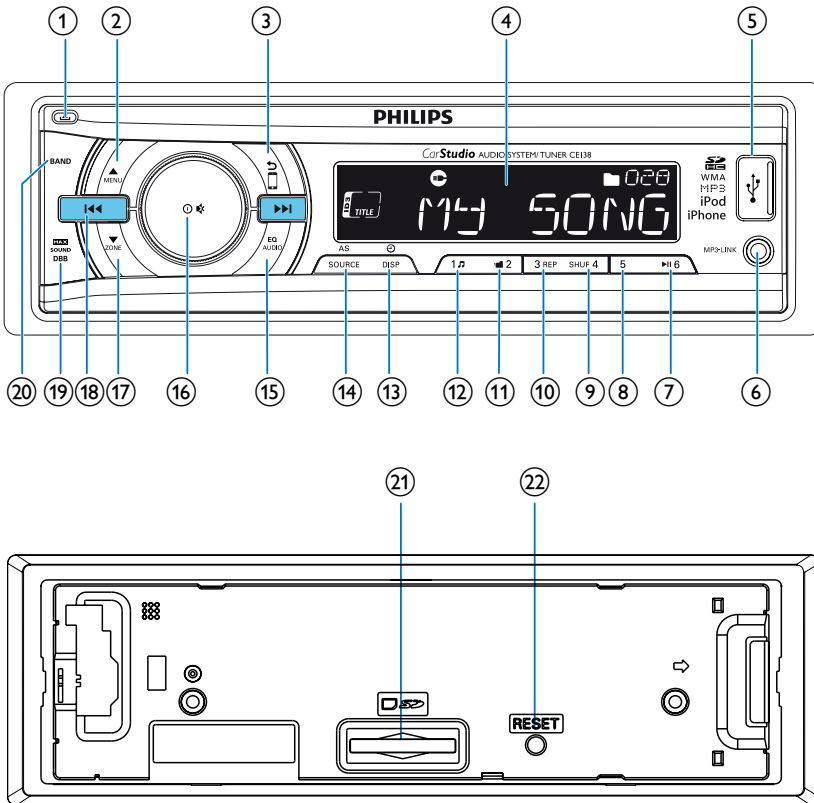

- ① Main unit (with a sleeve)
- ② Carrying case (with front panel included)
- ③ Trim plate
- ④ Disassembly tool X 2
- ⑤ ISO male connector X 2
- ⑥ Remote control
- ⑦ User manual

Overview of the system



- ① 
 - Unlock the front panel.
- ②  MENU
 - For .wma and .mp3 tracks, press to select the previous folder.
 - Press and hold to access the system menu.
 - Press to select a tuner band.
- ③ 
 - Return to the previous menu.
 - For iPod/iPhone, press repeatedly to select a control mode: control play on the iPod/iPhone or on this system.
- ④ LCD screen
- ⑤ 
 - Connect to a USB storage device.
 - Connect to a compatible iPod/iPhone.
- ⑥ MP3-LINK
 - Connect to the audio output socket (usually the headphone socket) of an external device.
- ⑦  6
 - Start, pause, or resume the play of tracks.
 - In radio mode, press to select the preset radio station of No. 6.

- In radio mode, press and hold to store the current radio station at channel No. 6.

⑧ 5

- In radio mode, press to select the preset radio station of No. 5.
- In radio mode, press and hold to store the current radio station at channel No. 5.

⑨ SHUF 4

- In radio mode, press to select the preset radio station of No. 4.
- In radio mode, press and hold to store the current radio station at channel No. 4.
- For .wma and .mp3 tracks, press repeatedly to select a play mode: play all tracks randomly ([SHU ALL]), play tracks in the current folder or album randomly ([SHU FLD]/[SHU ALBM]), or play all tracks in the storage device in sequence ([SHU OFF]).

⑩ 3 REP

- In radio mode, press to select the preset radio station of No. 3.
- In radio mode, press and hold to store the current radio station at channel No. 3.
- For .wma and .mp3 tracks, press repeatedly to select a repeat mode.

⑪ 2

- In radio mode, press to select the preset radio station of No. 2.
- In radio mode, press and hold to store the current radio station at channel No. 2.
- For .wma and .mp3 tracks on a storage device, press to access the folder list.

⑫ 1

- In radio mode, press to select the preset radio station of No. 1.
- In radio mode, press and hold to store the current radio station at channel No. 1.

- For .wma and .mp3 tracks on a storage device, press to access the track list.
- Press to access the music menu of an iPod/iPhone.

⑬ /DSP

- Press repeatedly to display available information about the current track.
- Press and hold to display the set clock.

⑭ AS/SOURCE

- Press repeatedly to select a source.
- In radio mode, press and hold to activate the automatic search of radio stations.

⑮ EQ AUDIO

- Press repeatedly to select a preset sound equalizer.
- Press and hold to activate the setup of bass, treble, balance, and fader:

⑯

- Press to turn on the system.
- Press and hold to turn off the system.
- Press to mute the speakers or release them from mute status.
- Press to confirm an option.
- Rotate to switch between menu options.
- Rotate to adjust the volume level.

⑰ ZONE

- For .wma and .mp3 tracks on a storage device, press to select the next folder.
- Press and hold to activate the selection of listening zones.
- Press to select a tuner band.

⑱ /

- Tune to a radio station.
- Press to skip to the previous/next track.
- Press and hold to rewind a track or search fast forward.

⑲ MAX SOUND DBB

- Press to enable or disable the maximum volume.

- Press and hold to enable or disable the DBB (dynamic bass boost) sound effect.

20 BAND

- Press repeatedly to select a tuner band.

21 Slot for SD/SDHC card

- Insert an SD/SDHC card.

22 RESET

- Press to reboot the system.

3 ◀◀ / ▶▶

- Tune to a radio station
- Skip to the previous or next track.
- Press and hold to rewind a track or search forward fast.

4 SOURCE

- Select an source.

5 EQ

- Select a preset sound equalizer (EQ).

6 OFF / 🔊

- Turn the system on or off.
- Mute the speakers or release them from mute status.

Overview of the remote control

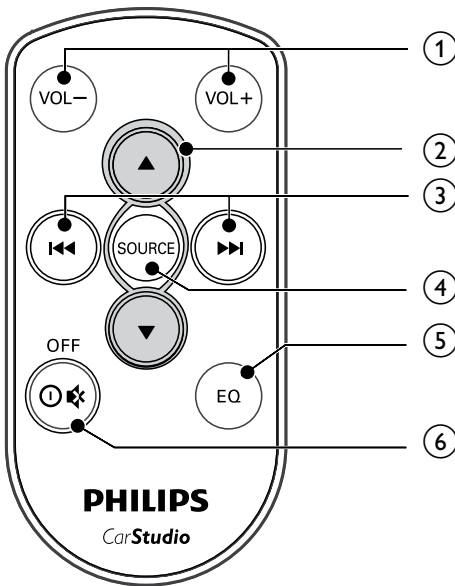

1 VOL +/VOL -

- Adjust the volume.

2 ▲ / ▼

- Select a tuner band.
- Toggle through menus.
- Select an MP3/WMA folder.

3 Install the car audio system

! Caution

- Use the controls only as stated in this user manual.

Always follow the instructions in this chapter in sequence.

These instructions are for a typical installation. However, if your car has different requirements, make the adjustment accordingly. If you have any question regarding installation kits, consult your local retailer.

≡ Note

- This system is designed for negative ground (earth) 12V DC operation only.
- Always install this system in the car dashboard. Other locations can be dangerous as the rear of the system heats up during use.
- To avoid short-circuit: before you connect, make sure that the ignition is off.
- Make sure that you connect the yellow and red power supply leads after all other leads are connected.
- Make sure that all loose leads are insulated with electrical tape.
- Make sure that the leads do not get caught under screws iron parts that will move (e.g. seat rail).
- Make sure that all ground (earth) leads are run to a common ground (earth) point.
- Use only the supplied mounting hardware for a safe and secure installation.
- Improper fuses can cause damage or fire. When you need to change the fuse, consult a professional.
- When you connect other devices to this system, make sure that the rating of the car circuit is higher than the total fuse value of all the connected devices.
- Never connect speaker wires to the metal body or chassis of the car.
- Never connect speaker wires with stripes to one another.

Connect wires

≡ Note

- Make sure that all loose leads are insulated with electrical tape.
- Consult a professional to connect wires as instructed below.

1 Check the car's wiring carefully and connect them to the the supplied ISO male connectors.

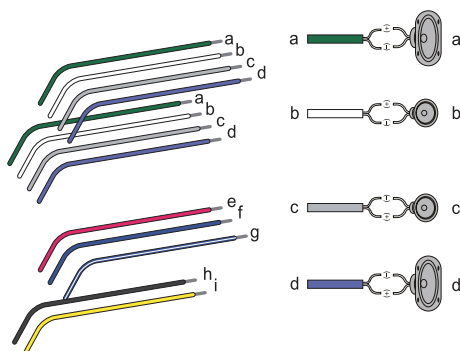

	ISO male connectors	Connect to
a	Green strip, black-edged green strip	Rear left speaker
b	White strip, black-edged white strip	Front left speaker
c	Gray strip, black-edged gray strip	Front right speaker
d	Purple strip, black-edged purple strip	Rear right speaker
e	Red strip	Ignition key +12V DC when ON/ACC
f	Blue strip	Motor/electric antenna relay control lead
g	White-edged blue strip	Amplifier relay control lead
h	Black strip	Ground
i	Yellow strip	To the +12V car battery which is energized at all times

- 2 Connect the antenna and amplifier as illustrated, if applicable.

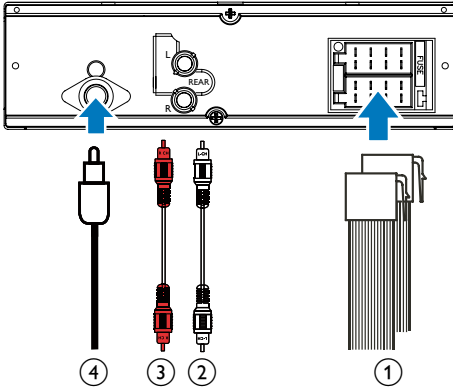

Sockets on rear panel	External sockets or connectors
1	For ISO male connectors As indicated above connectors
2	REAR L Rear left speaker
3	REAR R Rear right speaker
4	ANTENNA Antenna

 Tip

- The pin arrangement for the ISO connectors depends on the type of your vehicle. To avoid damage to the unit, connect properly.

Mount into the dashboard

- If the car does not have an on-board drive or navigation computer, disconnect the negative terminal of the car battery.
- If the car battery is not disconnected, to avoid short-circuit, make sure that the bare wires do not touch each other.

- 1 Make sure that the car dashboard opening is within these measurements:

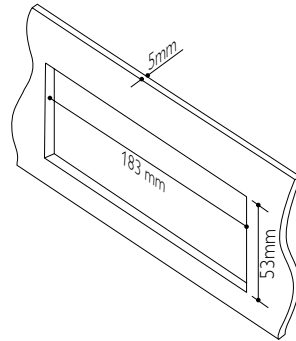

- 2 Remove the mounting sleeve with the supplied disassembly tools.

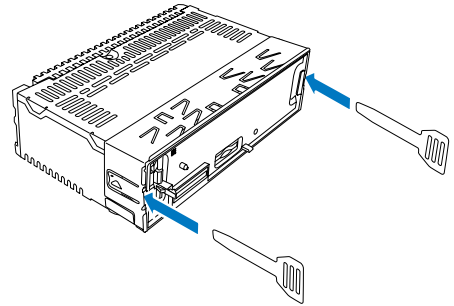

- 3 Install the sleeve into the dashboard and bend the tabs outward to fix the sleeve.

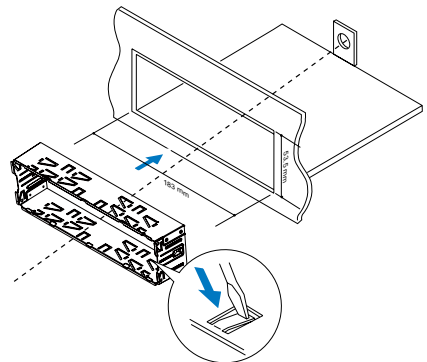

- 4 Slide the unit into the sleeve until you hear a "click".

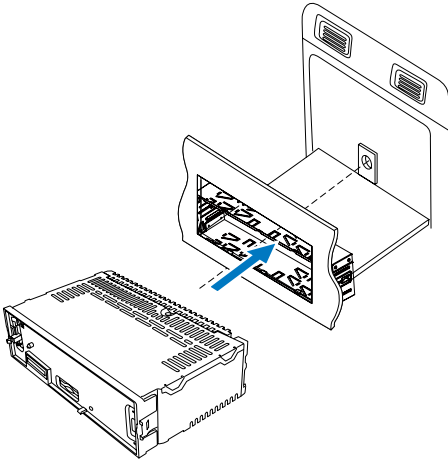

- 5 Attach the trim plate.

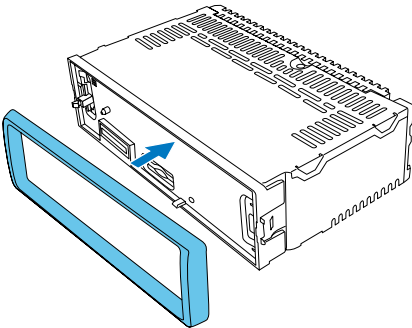

- 6 Reconnect the negative terminal of the car battery.

Attach the front panel

- 1 Insert the notch on the front panel to the chassis on the main unit.

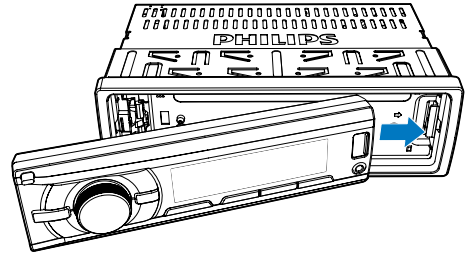

- 2 Press the left end of the front panel inwards until it is securely locked with a "click".

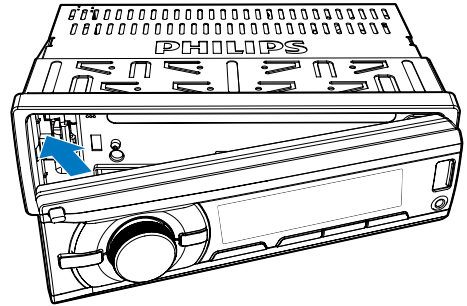

Detach the front panel

Note

- Before you insert an SD/SDHC card or reset the system, detach the front panel.
- Before you detach the front panel, make sure that the system is turned off.

- 1 Press  to release the front panel.
- 2 Pull the front panel outwards to remove it.

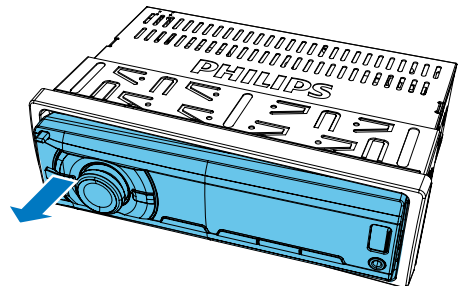

4 Get started

For the first time use

- 1 Press **⏻** **⌘** to turn on the system.
↳ **[PHILIPS]** is displayed and then **[SELECT OPERATING REGION]** (select a radio region) scrolls.
- 2 When one of the following options is displayed, rotate **⏻** **⌘** to select a radio region that matches your location.
 - **[AREA EUROPE]** (Western Europe)
 - **[AREA ASIA]** (Asia Pacific)
 - **[AREA MID--EAST]** (Middle East)
 - **[AREA AUST]** (Australia)
 - **[AREA RUSSIA]** (Russia)
 - **[AREA USA]** (United States)
 - **[AREA LATIN]** (Latin America)
 - **[AREA JAPAN]** (Japan)
- 3 Press **⏻** **⌘** to confirm.
↳ The system switches to radio mode automatically.
 - To turn off the system, press and hold **⏻** **⌘** until the screen backlight is off.

Set the time format

- 1 Press and hold **▲** **MENU** to access the system menu.
- 2 Press **▲** **MENU** / **▼** **ZONE** repeatedly until **[CLK 24H]** or **[CLK 12H]** is displayed.
- 3 Rotate **⏻** **⌘** to select **[CLK 24H]** or **[CLK 12H]**.
 - **[CLK 24H]**: 24-hour time format
 - **[CLK 12H]**: 12-hour time format

Set the clock

- 1 Press and hold **▲** **MENU** to access the system menu.
- 2 Press **▲** **MENU** / **▼** **ZONE** repeatedly until **[CLK]** is displayed with time digits blinking.
- 3 Rotate **⏻** **⌘** anti-clockwise to set the hour.
- 4 Rotate **⏻** **⌘** clockwise to set the minute.

Display the clock

Press and hold **⊕** / **DISP** until **[CLK]** and the set clock are displayed.

- To exit the clock display, press any button or rotate **⏻** **⌘**.

Select a source

Press **AS/SOURCE** repeatedly to select a source.

- **[RADIO]**: Listen to FM/AM radio.
- **[MP3--LINK]**: Listen to the audio input through the **MP3-LINK** socket.
- **[iPod/USB]**: When a USB storage device or compatible iPod/iPhone is connected and recognized, you can select this source to play audio files that are stored on it.
- **[SD/SDHC]**: When an SD/SDHC card is inserted and recognized, you can select this source to play audio files that are stored on it.

Select a listening zone

- 1 Press and hold **▼** **ZONE** until one of the following options is displayed.
 - **[ALL]**: For all passengers
 - **[FRONT-L]**: For the front-left seat only
 - **[FRONT-R]**: For the front-right seat only
 - **[FRONT]**: For front passengers only
- 2 Press **▲** **MENU** / **▼** **ZONE** repeatedly to select a listening zone.

Mute the button beep

The beep sound of buttons is enabled by default.

- 1 Press and hold **MENU** to access the system menu.
- 2 Press **MENU** / **ZONE** repeatedly until **[BEEP ON]** or **[BEEP OFF]** is displayed.
 - **[BEEP ON]**: Enable the beep sound of buttons.
 - **[BEEP OFF]**: Mute the beep sound of buttons.
- 3 Rotate **⊖** / **⊕** to change the setting.

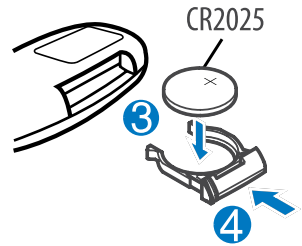
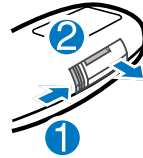

Install/replace the remote control battery

! Caution

- Risk of explosion! Keep batteries away from heat, sunshine or fire. Never discard any battery in fire.
- Risk of product damage! When the remote control is not to be used for a long period, remove the battery.
- Perchlorate Material - special handling may apply. See www.dtsc.ca.gov/hazardouswaste/perchlorate.

For the first time use

Remove the protective tab to activate the remote control battery.

To replace the remote control battery:

- 1 Open the battery compartment.
- 2 Insert one CR2025 battery with correct polarity (+/-) as indicated.
- 3 Close the battery compartment.

5 Listen to radio





Select a tuner region

You can select a radio region that matches your location.

- 1 In radio mode, press and hold  **MENU** to access the system menu.
- 2 Press  /  repeatedly until one of the following options is displayed.
 - **[AREA EUROPE]** (Western Europe)
 - **[AREA ASIA]** (Asia Pacific)
 - **[AREA MID--EAST]** (Middle East)
 - **[AREA AUST]** (Australia)
 - **[AREA RUSSIA]** (Russia)
 - **[AREA USA]** (United States)
 - **[AREA LATIN]** (Latin America)
 - **[AREA JAPAN]** (Japan)
- 3 Rotate   to select a region.



Select a tuner sensitivity

To search for radio stations with strong signals only or more radio stations, you can change the tuner sensitivity.



- 1 Press and hold  **MENU** to access the system menu.
- 2 Press  /  repeatedly until **[LOC ON]** or **[LOC OFF]** is displayed.
- 3 Rotate   to select a setting.
 - **[LOC ON]**: Search for radio stations with strong signals only.
 - **[LOC OFF]**: Search for radio stations with strong and weak signals.

Search for a radio station

Search for a radio station automatically

Press  or  to search for the previous or next radio station with strong signals.

Search for a radio station manually

- 1 Press and hold  or  until **[M]** blinks.
- 2 Press  or  repeatedly until the target frequency is displayed.





Store radio stations in memory











Note

- You can store a maximum of six stations in each band.

Store radio stations automatically

- 1 Switch the source to **[RADIO]**.
- 2 Press **BAND**,  **MENU**, or  repeatedly to select a band.
- 3 Press and hold **AS/SOURCE** until **[STORE---**] is displayed.
 - ↳ After the search is complete, the first stored radio station is broadcast automatically.
 - To select a stored radio station, press **1**  **2**  **3** **REP**, **SHUF** **4**, **5**, or **▶** **6**.

Store radio stations manually

- 1 Press **BAND**,  **MENU**, or  **ZONE** repeatedly to select a tuner band.
- 2 Tune to the radio station that you want to store.
- 3 Press and hold **1**  **2**  **3** **REP**, **SHUF** **4**, **5**, or  **6** to store the radio station at the selected channel.
 - To select a stored radio station, press **1**  **2**  **3** **REP**, **SHUF** **4**, **5**, or  **6**.

6 Play from a storage device

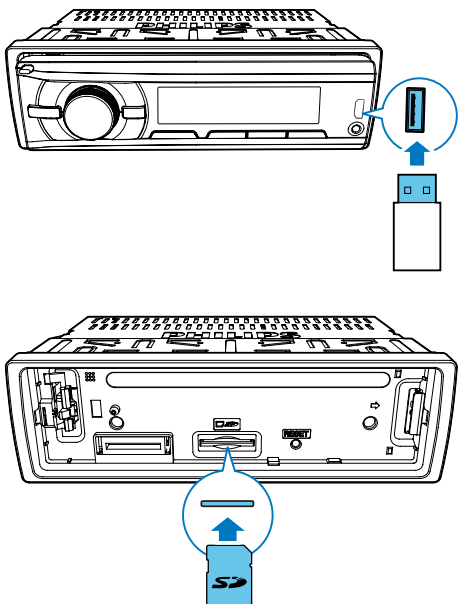

- 1 Connect a compatible USB storage device or SD/SDHC card.
 - For an SD/SDHC card, detach the front panel first, insert the card into the card slot, and then attach the front panel.
- 2 Switch the source to **[iPod/USB]** or **[SD/SDHC]**.
 - When a USB storage device is connected and recognized, the system switches the source to **[iPod/USB]** automatically.
- 3 If the play does not start, press **▶||6**.

Control play

Button	Function
▲ / ▼ MENU / ZONE	Press repeatedly to select a folder.
▶ 6	Pause or resume play.
⏮ / ⏭	Press to play the previous or next track.
⏮ / ⏭	Press and hold to rewind a track or search forward fast.
⌚ / DISP	Press repeatedly to display available information about the current track.
3 REP	Press repeatedly to select a repeat mode: <ul style="list-style-type: none"> • [REP ONE]: repeat the current track, • [RPT FLD]: repeat all tracks in the current folder; or • [RPT ALL]: repeat all tracks in the storage device.
SHUF 4	Press repeatedly to select a play mode: <ul style="list-style-type: none"> • [SHU ALL]: play all tracks randomly, • [SHU FLD]: play tracks in the current folder randomly; or • [SHU OFF]: play all tracks in the storage device in sequence.

Switch tracks

During play, you can switch tracks or folders quickly.

Switch tracks directly

- 1 Press **1** **🎵** to access the track list.
↳ The file name of current track scrolls.
- 2 Rotate **⌚** **🔍** to toggle through tracks.
- 3 Press **⌚** **🔍** to play the selected track.

Switch folders for a track

- 1 Press **■** **2** to access the folder list.
↳ The name of current folder scrolls.
- 2 Rotate **⌚** **⌘** to toggle through folders.
- 3 Press **⌚** **⌘** to select the folder.
↳ The system starts playing the first track under the folder.

7 Play from an iPod/iPhone

Note

- During play, no audio signals are transferred through the headphone socket of your iPod/iPhone.

Compatible iPod/iPhone models

This car audio system supports the following iPod and iPhone models.

- iPhone 4S, iPhone 4, iPhone 3GS, and iPhone 3G
- iPod touch (2nd, 3rd, and 4th generations)
- iPod classic
- iPod nano (3rd, 4th, 5th, and 6th generations)

Connect your iPod/iPhone

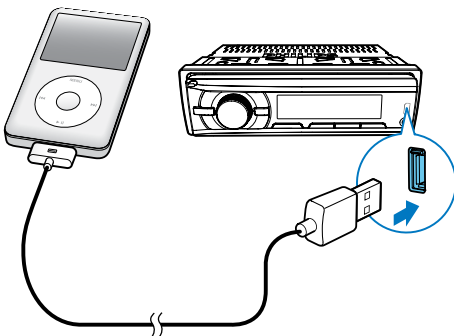

Connect an Apple 30-pin USB cable to:

- the USB socket on the front panel of this system, and
- your iPod/iPhone.
 - ↳ [iPod/USB] scrolls.
 - ↳ The system starts playing tracks that are stored on your iPod/iPhone.

Note

- Before you disconnect the iPod/iPhone, switch the system to another source.



Control play

Button	Function
	Press repeatedly to select a control mode: control play on your iPod/iPhone, or on the system.
	Press to pause or resume play.
	Press to play the previous or next track.
	Press and hold to rewind a track or search forward fast.
	Press repeatedly to display available information about the current track.
	Press repeatedly to select a repeat mode: <ul style="list-style-type: none">• [REP ONE]: repeat the current track, or• [REP ALL]: repeat all tracks.
	Press repeatedly to select a play mode: <ul style="list-style-type: none">• [SHU ALL]: play all tracks randomly,• [SHU ALBM]: play tracks in the current album randomly, or• [SHU OFF]: play all tracks in the iPod/iPhone library in sequence.

Search for a track

After accessing the iPod/iPhone menu, you can select a specific track quickly.

- 1 Press **1** to access the iPod/iPhone menu.
 - ↳ [PLAYLIST] scrolls.
- 2 Rotate to select a category.
- 3 Press to access the list of tracks under the category.
 - ↳ The file name of the first track scrolls.

- 4 Rotate  to select a track.
↳ The file name of current track scrolls.
- 5 Press  to start play.

Charge your iPod/iPhone

Once the iPod/iPhone is docked and recognized, the charging starts.

8 Listen to an external player

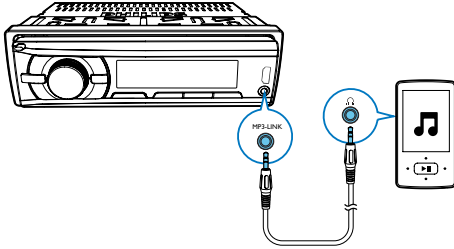

You can use the system to amplify the audio input from an external player, for example, MP3 player:



- 1 Switch the source to **[MP3--LINK]**.
- 2 Connect an MP3 link cable to
 - the **MP3-LINK** socket on the system, and
 - the audio output socket (usually the headphone socket) on the external player.
- 3 Play the external player.

9 Adjust sound

The following operations are applicable to all supported media.

Button	Function
	Rotate to increase or decrease the volume level.
	Press to mute the speakers or release them from mute status.
MAX SOUND DBB	Press to enable or disable the maximum volume.
MAX SOUND DBB	Press and hold to enable or disable the Dynamic Bass Boost (DBB) effect.
EQ AUDIO	Press repeatedly to select a sound equalizer.
EQ AUDIO	<ol style="list-style-type: none">1 Press and hold to activate the setup of customized sound equalizer.2 Press repeatedly to select an option: [BAS] (bass), [TRE] (treble), [BAL] (balance), or [FAD] (fader).3 Rotate  to adjust the setting.

10 Additional information

Reset the system

If the system works abnormally, reset the system to factory default settings.

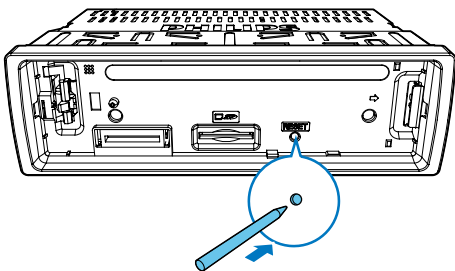

- 1 Detach the front panel.
- 2 Press the **RESET** button with the tip of a ball-point pen or toothpick.
↳ All settings are reset to factory default.

Replace the fuse

If there is no power, check the fuse and replace it if it is damaged.

- 1 Check the electric connection.
- 2 Remove the damaged fuse from the rear panel.

- 3 Insert a new fuse with the same specifications (15 A).

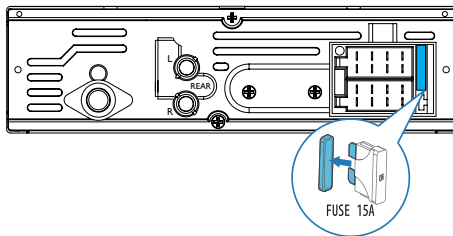

Note

- If the fuse gets damaged immediately after it is replaced, an internal malfunction may occur. In such case, consult your Philips retailer.

11 Product Information

Note

- Specifications are subject to change without prior notice.

General

Power supply	12V DC (11V - 16V), negative ground
Fuse	15 A
Suitable speaker impedance	4 - 8 Ω
Maximum power output	50 W \times 4 channels
Continuous power output	22 W \times 4 RMS (4 Ω 10% T.H.D.)
Pre-Amp output voltage	2.5 V
Aux-in level	\geq 500 mV

Radio

Frequency range - FM	87.5 - 108.0 MHz (100kHz per step in auto search and 50kHz per step in manual search)
Usable sensitivity - FM (S/N = 20 dB)	8 μ V
Frequency range - AM(MW)	522 - 1620 KHz (9 kHz) 530 - 1710 kHz (10 kHz)
Usable sensitivity - AM(MW) (S/N = 20 dB)	30 μ V

12 Troubleshooting



Warning

- Never remove the casing of this product.

To keep the warranty valid, never try to repair the product yourself.

If you encounter problems when using this product, check the following points before requesting service. If the problem remains unsolved, go to the Philips Web page (www.philips.com/support). When you contact Philips, make sure that the product is nearby and the model number and serial number are available.

No power or no sound

- The power supply from car battery is cut off, or the car battery runs out of energy. Power the system with car battery.
- Car engine is not on. Turn the car engine on.
- Cable is not correctly connected. Check connections.
- The fuse is burnt. Replace the fuse.
- Volume is too low. Adjust volume.
- If the above solutions cannot help, press the **RESET** button.
- Make sure that the current track is in a compatible format.

Noise in broadcasts

- Signals are too weak. Select other stations with stronger signals.
- Check the connection of the car antenna.
- Change the broadcast setting from stereo to mono.

Preset stations are erased.

- Battery cable is not correctly connected. Connect the battery cable to the terminal that is always live.

Cannot switch the source to iPod/iPhone

- Check whether the iPod/iPhone is securely connected.

- Check whether the iPod/iPhone is compatible with this system.
- Check whether the iPod/iPhone battery is nearly empty. Connect it to this system for charging first.

Display shows ERR-12.

- Data error. Check the USB storage device or SD/SDHC card.

13 Notice

Any changes or modifications made to this device that are not expressly approved by Philips Consumer Lifestyle may void the user's authority to operate the equipment.

Care of the environment



Your product is designed and manufactured with high quality materials and components, which can be recycled and reused. Never dispose of your product with other household waste. Please inform yourself about the local rules on the separate collection of electrical and electronic products and batteries. The correct disposal of these products helps prevent potentially negative consequences on the environment and human health. Your product contains batteries, which cannot be disposed of with normal household waste. Please inform yourself about the local rules on separate collection of batteries. The correct disposal of batteries helps prevent potentially negative consequences on the environment and human health. Please visit www.recycle.philips.com for additional information on a recycling center in your area.

Environmental information

All unnecessary packaging has been omitted. We have tried to make the packaging easy to separate into three materials: cardboard (box), polystyrene foam (buffer) and polyethylene (bags, protective foam sheet.) Your system consists of materials which can be recycled and reused if disassembled by a specialized company. Please observe the local regulations regarding the disposal of packaging materials, exhausted batteries and old equipment.

Trademark notice



Windows Media and the Windows logo are trademarks, or registered trademarks of Microsoft Corporation in the United States and/or other countries.



"Made for iPod" and "Made for iPhone" mean that an electronic accessory has been designed to connect specifically to iPod or iPhone respectively, and has been certified by the developer to meet Apple performance standards. Apple is not responsible for the operation of this device or its compliance with safety and regulatory standards. Please note that the use of this accessory with iPod or iPhone may affect wireless performance. iPod and iPhone are trademarks of Apple Inc., registered in the U.S. and other countries. Other trademarks and trade names are those of their respective owners.

Copyright

2012 © Koninklijke Philips Electronics N.V. Specifications are subject to change without notice. Trademarks are the property of Koninklijke Philips Electronics N.V or their respective owners. Philips reserves the right to change products at any time without being obliged to adjust earlier supplies accordingly.

14 Glossary

M

MP3

A file format with a sound data compression system. MP3 is the abbreviation of Motion Picture Experts Group 1 (or MPEG-1) Audio Layer 3.

S

SD

Secure Digital. A type of memory card with a flash memory.

SDHC

Secure Digital High Capacity (SDHC) is a type of flash memory card based on the SDA 2.00 specification. The SDA 2.00 specification enables SD cards to reach higher capacities from 4GB to 32GB, and growing.

W

WMA (Windows Media Audio)

An audio format owned by Microsoft, is a part of Microsoft Windows Media technology. Includes Microsoft Digital Rights Management tools, Windows Media Video encoding technology, and Windows Media Audio encoding technology.



Specifications are subject to change without notice
© 2012 Koninklijke Philips Electronics N.V.
All rights reserved.

CE138_94_UM_V2.0

