

Register your product and get support at
www.philips.com/welcome

DCB293



EN User manual

PHILIPS

Contents

1 Important	4
Safety	4
Notice	5

2 Your Micro Hi-Fi System	7
Introduction	7
What's in the box	7
Overview of the main unit	8
Overview of the remote control	9

3 Get started	11
Placement	11
Prepare the remote control	11
Connect power	11
Auto install radio stations	12
Set clock	12
Turn on	12

4 Play	13
Play a disc	13
Play from USB	13
Play iPod/iPhone	13

5 Listen to radio	15
Listen to Digital Audio Broadcasts (DAB+)	15
Listen to FM radio	17

6 Play options	18
Pause/resume play	18
Skip to a track	18
Search within a track	18
Select repeat/shuffle play options	18
Program tracks	18
Display time	18
Adjust volume level	18
Mute sound	19
Select a preset sound effect	19
Enhance bass	19

7 Other features	20
Set the alarm timer	20
Set the sleep timer	20
Play from an external device	20
Listen through headphone	20

8 Product information	21
Specifications	21
USB playability information	22
Supported MP3 disc formats	22
Maintenance	22

9 Troubleshooting	23
--------------------------	----

1 Important

Safety

Important Safety Instructions

- ① Read these instructions.
- ② Keep these instructions.
- ③ Heed all warnings.
- ④ Follow all instructions.
- ⑤ Do not use this apparatus near water.
- ⑥ Clean only with dry cloth.
- ⑦ Do not block any ventilation openings. Install in accordance with the manufacturer's instructions.
- ⑧ Do not install near any heat sources such as radiators, heat registers, stoves, or other apparatus (including amplifiers) that produce heat.
- ⑨ Protect the power cord from being walked on or pinched, particularly at plugs, convenience receptacles, and the point where they exit from the apparatus.
- ⑩ Only use attachments/accessories specified by the manufacturer.
- ⑪ Use only with the cart, stand, tripod, bracket, or table specified by the manufacturer or sold with the apparatus. When a cart is used, use caution when moving the cart/apparatus combination to avoid injury from tip-over.



- ⑫ Unplug this apparatus during lightning storms or when unused for long periods of time.
- ⑬ Refer all servicing to qualified service personnel. Servicing is required when the apparatus has been damaged in any way, such as power-supply cord or plug is damaged, liquid has been spilled or objects have fallen into the apparatus, the apparatus has been exposed to rain or moisture, does not operate normally, or has been dropped.
- ⑭ **Battery usage CAUTION** – To prevent battery leakage which may result in bodily injury, property damage, or damage to the unit:
 - Install all batteries correctly, + and - as marked on the unit.
 - Do not mix batteries (old and new or carbon and alkaline, etc.).
 - Remove batteries when the unit is not used for a long time.
- ⑮ Apparatus shall not be exposed to dripping or splashing.
- ⑯ Do not place any sources of danger on the apparatus (e.g. liquid filled objects, lighted candles).
- ⑰ Where the MAINS plug or an appliance coupler is used as the disconnect device, the disconnect device shall remain readily operable.



Warning

- Never remove the casing of this apparatus.
- Never lubricate any part of this apparatus.
- Never place this apparatus on other electrical equipment.
- Keep this apparatus away from direct sunlight, naked flames or heat.
- Never look into the laser beam inside this apparatus.
- Ensure that you always have easy access to the power cord, plug or adaptor to disconnect this apparatus from the power.

Hearing safety

Listen at a moderate volume.

- Using headphones at a high volume can impair your hearing. This product can produce sounds in decibel ranges that may cause hearing loss for a normal person, even for exposure less than a minute. The higher decibel ranges are offered for those that may have already experienced some hearing loss.
- Sound can be deceiving. Over time your hearing 'comfort level' adapts to higher volumes of sound. So after prolonged listening, what sounds 'normal' can actually be loud and harmful to your hearing. To guard against this, set your volume to a safe level before your hearing adapts and leave it there.

To establish a safe volume level:

- Set your volume control at a low setting.
- Slowly increase the sound until you can hear it comfortably and clearly, without distortion.

Listen for reasonable periods of time:

- Prolonged exposure to sound, even at normally 'safe' levels, can also cause hearing loss.
- Be sure to use your equipment reasonably and take appropriate breaks.

Be sure to observe the following guidelines when using your headphones.

- Listen at reasonable volumes for reasonable periods of time.
- Be careful not to adjust the volume as your hearing adapts.
- Do not turn up the volume so high that you can't hear what's around you.
- You should use caution or temporarily discontinue use in potentially hazardous situations. Do not use headphones while operating a motorized vehicle, cycling, skateboarding, etc.; it may create a traffic hazard and is illegal in many areas.

Notice

Any changes or modifications made to this device that are not expressly approved by Philips Consumer Lifestyle may void the user's authority to operate the equipment.



This product complies with the radio interference requirements of the European Community.



Your product is designed and manufactured with high quality materials and components, which can be recycled and reused.



When this crossed-out wheeled bin symbol is attached to a product it means that the product is covered by the European Directive 2002/96/EC.

Please inform yourself about the local separate collection system for electrical and electronic products.

Please act according to your local rules and do not dispose of your old products with your normal household waste. Correct disposal of your old product helps to prevent potential negative consequences for the environment and human health.



Your product contains batteries covered by the European Directive 2006/66/EC, which cannot be disposed with normal household waste. Please inform yourself about the local rules on separate collection of batteries because correct disposal helps to prevent negative consequences for the environmental and human health.

Environmental information

All unnecessary packaging has been omitted. We have tried to make the packaging easy to separate into three materials: cardboard (box), polystyrene foam (buffer) and polyethylene (bags, protective foam sheet.)

Your system consists of materials which can be recycled and reused if disassembled by a specialized company. Please observe the local regulations regarding the disposal of packaging materials, exhausted batteries and old equipment.



The making of unauthorized copies of copy-protected material, including computer programs, files, broadcasts and sound recordings, may be an infringement of copyrights and constitute a criminal offence. This equipment should not be used for such purposes.



Windows Media and the Windows logo are trademarks, or registered trademarks of Microsoft Corporation in the United States and/or other countries.

This apparatus includes this label:



Note

- The type plate is located on the bottom of the apparatus.

2 Your Micro Hi-Fi System

Congratulations on your purchase, and welcome to Philips! To fully benefit from the support that Philips offers, register your product at www.philips.com/welcome.

Introduction

With this unit, you can enjoy audio from discs, USB devices, iPod players, iPhone and listen to tuner/Digital Audio Broadcasting (DAB) radio stations, or other external devices.

The unit offers Digital Sound Control (DSC) and Dynamic Bass Boost (DBB) to enrich sound.

The unit supports the following media formats:



What's in the box

Check and identify the contents of your package:

- Main unit
- Remote control
- Power adaptor
- 1 x MP3 link cable
- Mounting kit (2 dowels and 2 screws)
- Quick start guide
- User manual
- Wall mounting instructions

Overview of the main unit

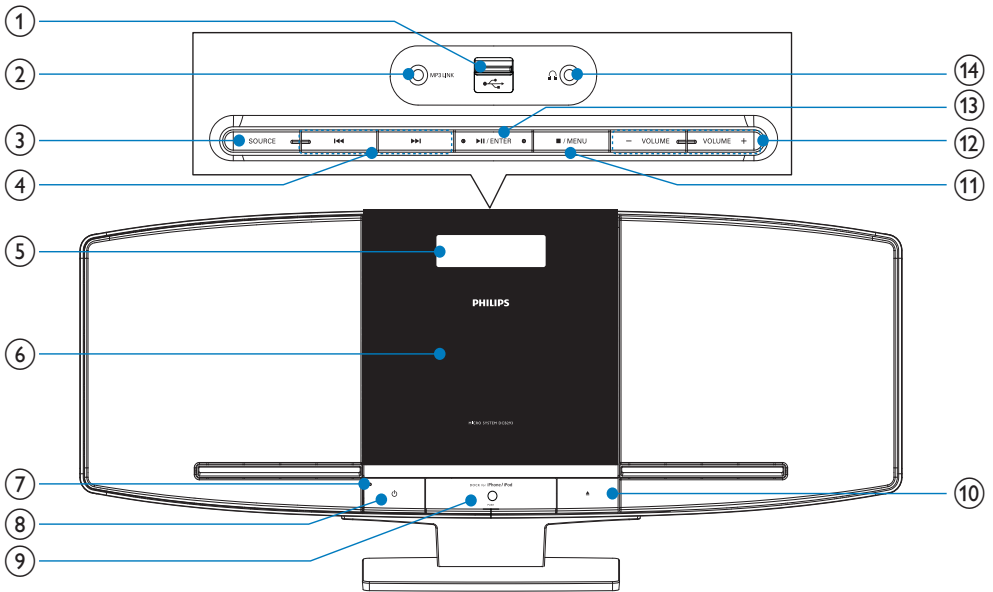

- ①
 - Jack for a USB mass storage device.
- ② **MP3 LINK**
 - Audio input jack (3.5mm) for an external audio device.
- ③ **SOURCE**
 - Select a source: CD, iPod, FM/DAB, USB, or MP3 link.
- ④
 - Skip to the previous/next track.
 - Search within a track.
 - Tune to a radio station.
 - Adjust hour/minute digits.
 - Select 12 hour or 24 hour format.
- ⑤ **Display panel**
 - Show current status.
- ⑥ **Disc compartment**
- ⑦ **Eco-power indicator**
- ⑧
 - Turn on the unit, or switch to standby mode, or switch to Eco Power standby.
- ⑨ **Dock for iPod/iPhone**
- ⑩
 - Open/close the disc compartment.
- ⑪
 - Stop play or erase a program.
 - Access and exit a menu.
- ⑫ **VOLUME + / -**
 - Adjust volume.
- ⑬
 - Start or pause play.
 - Confirm a selection.
 - Access the iPod menu.
 - In FM mode, switch between mono and stereo signals.
- ⑭
 - Headphones jack.

⑭



- Jack for the headphone.

Overview of the remote control

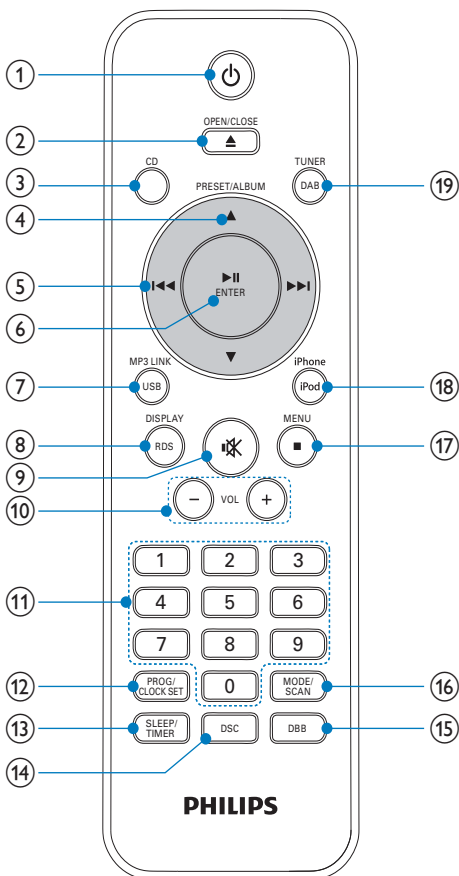

①

- Turn on the unit, or switch to standby mode, or switch to Eco Power standby.

② **OPEN/CLOSE▲**

- Open or close the disc compartment.

③ **CD**

- Select disc source.

④ **▲▼**

- Navigate in the iPod/DAB menu.
- Skip to the previous/next album.
- Skip to the previous/next radio station.

⑤ **◀▶**

- Navigate in the iPod/DAB menu.
- Skip to the previous/next album.
- Skip to the previous/next track.
- Search within a track.
- Tune to a radio station.
- Adjust hour/minute digits.
- Select 12 hour or 24 hour format.

⑥ **▶||/ENTER**

- Start or pause play.
- Confirm a selection.
- Access the iPod menu.
- In FM mode, switch between mono and stereo signals.

⑦ **USB/MP3 LINK**

- Select USB device source.
- Select external audio device source.

⑧ **RDS/DISPLAY (RDS not available)**

- Display time.
- Display DAB information.
- Select display information during play.

⑨ **🔇**

- Mute or restore volume.

⑩ **VOL +/-**

- Adjust volume.

⑪ **Numeric keypad**

- Select a track from a disc directly.
- Select a preset radio station.

⑫ **PROG/CLOCK SET**

- Program tracks.
- Program radio stations.
- Set the clock.

⑬ **SLEEP/TIMER**

- Set the sleep timer.
- Set the alarm timer.

- ⑭ **DSC**
 - Select a preset sound setting.
- ⑮ **DBB**
 - Turn on or off dynamic bass enhancement.
- ⑯ **MODE/SCAN**
 - Select repeat/shuffle play mode.
 - Scan FM/DAB radio stations.
- ⑰ **■/MENU**
 - Stop play or erase a program.
 - Access and exit a menu.
- ⑱ **iPod/iPhone**
 - Select iPod/iPhone source.
- ⑲ **DAB/TUNER**
 - Select DAB/tuner source.

3 Get started

! Caution

- Use of controls or adjustments or performance of procedures other than herein may result in hazardous radiation exposure or other unsafe operation.

Always follow the instructions in this chapter in sequence.

If you contact Philips, you will be asked for the model and serial number of this apparatus. The model number and serial number are on the rear of the apparatus. Write the numbers here:

Model No. _____

Serial No. _____

Placement

You can place the unit on a flat surface or mount the unit on a wall.

Mount on a wall

To wall mount the unit, see the included separate sheet of wall mounting instructions.

Prepare the remote control

! Caution

- Risk of explosion! Keep batteries away from heat, sunshine or fire. Never discard batteries in fire.

To insert the remote control battery:

- 1 Open the battery compartment.
- 2 Insert 2 AAA batteries (not supplied) with correct polarity (+/-) as indicated.
- 3 Close the battery compartment.

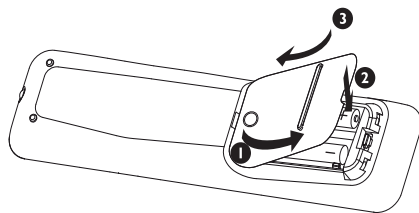

≡ Note

- If you are not going to use the remote control for a long time, remove the batteries.
- Do not use old and new or different types of batteries in combination.
- Batteries contain chemical substances, so they should be disposed of properly.

Connect power

! Caution

- Risk of product damage! Ensure that the power voltage corresponds to the voltage printed on the back or underside of the apparatus.
- Risk of electric shock! When you unplug the AC adaptor, always pull the plug from the socket. Never pull the cord.
- Before connecting the AC adaptor, ensure you have completed all other connections.

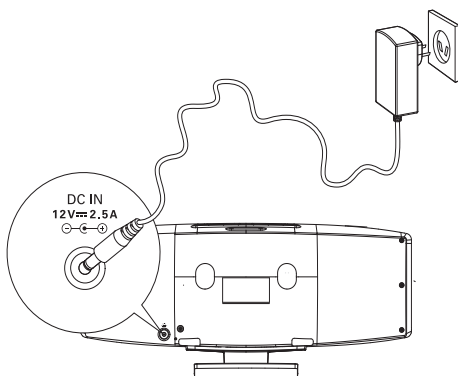

- 1 Connect the power adaptor to:
 - the **DC IN** jack on the main unit.
 - the wall outlet.

Auto install radio stations

When you connect power and no radio stations are stored, the unit automatically begins to store radio stations.

- 1 Connect the unit to the power supply.
↳ [AUTO INSTALL PRESS - PLAY KEY](auto install press - play key) is displayed.
- 2 Press ►|| on the main unit to start installation.
↳ The unit automatically stores radio stations with sufficient signal strength.
↳ When all the available radio stations are stored, the first preset radio station is broadcast automatically.

Set clock

Note

- You can set the clock in the standby mode only.

- 1 Press and hold **PROG/CLOCK SET** to enter the clock setting mode.
↳ [SET CLOCK] (set clock) scrolls on the screen.
↳ [Synch On] (synch on) is displayed.
- 2 Press ◀◀▶▶ to select [Y] or [N].
 - [Y]: the unit reads the DAB/RDS time and sets the clock automatically.
 - [N]: the unit turns off the time synchronization.
- 3 Press **PROG/CLOCK SET** to confirm.
- 4 Press ◀◀▶▶ repeatedly to select 12 hour or 24 hour format.
- 5 Press **PROG/CLOCK SET** to confirm.
↳ The hour digits are displayed and begin to blink.
- 6 Press ◀◀▶▶ to set the hour.

- 7 Press **PROG/CLOCK SET** to confirm.
↳ The minute digits are displayed and begin to blink.
- 8 Press ◀◀▶▶ to set the minute.
- 9 Press **PROG/CLOCK SET** to confirm the clock setting.

Turn on

- 1 Press ⏻.
↳ The unit switches to the last selected source.

Switch to standby

- 1 Press ⏻ again to switch the unit to standby mode.
↳ The clock (if set) appears on the display panel.

To switch the unit to Eco Power Standby mode:

- 1 Press and hold ⏻ for more than 2 seconds.
↳ The backlight on the display panel turns off.

Tip

- The unit switches to Eco Power Standby mode after 15 minutes in standby mode.

To switch between standby mode and Eco Standby Mode:

- 1 Press and hold ⏻ for more than 2 seconds.

4 Play

Play a disc

- 1 Press **CD** to select the disc source.
- 2 Press **▲** to open the disc compartment.
- 3 Insert a disc with the printed side facing outward.
- 4 Press **▲** to close the disc compartment.
↳ Play starts automatically. If not, press **▶||**.

Play from USB

Note

- Ensure that the USB device contains playable audio content.

- 1 Insert the USB device into the  socket.

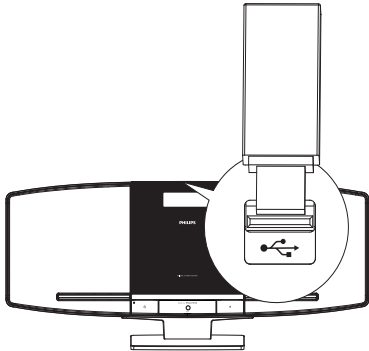

- 2 Press **USB** to select the USB source.
↳ Play starts automatically. If not, press **▶||**.
 - To select a folder, press **▲/▼**.
 - To select an audio file, press **◀◀▶▶▶**.

Play iPod/iPhone

You can enjoy audio from iPod/iPhone through this Micro Hi-Fi system.

Compatible iPod/iPhone

Apple iPod and iPhone models with a 30-pin dock connector:

- iPod classic, iPod touch, iPod nano, iPod 5th generation (video), iPod with color display, iPod mini
- iPhone, iPhone 3G, iPhone 3GS

Play an iPod/iPhone player

Note

- When an iPod/iPhone player is loaded, the unit switches to iPod source automatically.

- 1 Push to open the dock compartment.

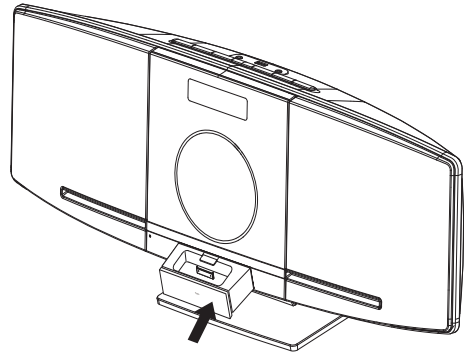

- 2 Place the iPod/iPhone player in the dock.

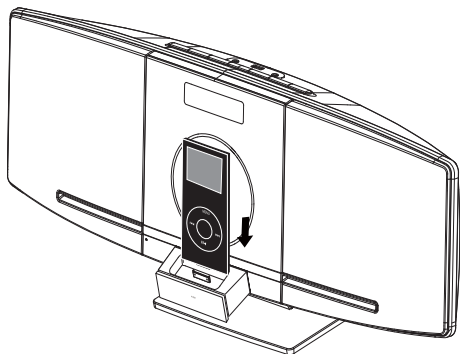

- 3** Press **iPod** to select iPod source.
- To pause/resume play, press **▶||**.
 - To skip to a track, press **◀◀▶▶**.
 - To search during play, press and hold **◀◀▶▶**, then release to resume normal play.

Charge the iPod/iPhone

When the unit is connected to power, the docked iPod/iPhone begins to charge.

5 Listen to radio

Listen to Digital Audio Broadcasts (DAB+)

Digital Audio Broadcasting (DAB+), is a way of broadcasting radio digitally through a network of transmitters. It provides you with more choice, better sound quality and more information.

- 1 Press **SOURCE** repeatedly to select **[DAB+]**.
 - ↳ When you enter the DAB+ mode for the first time, the unit automatically scans DAB+ radio stations. The unit stores all available DAB+ radio stations and then broadcasts the first available station.
 - ↳ The last selected DAB+ radio station broadcasts automatically.



Tip

- If no DAB+ service is available, **[NO DAB STATION]** is displayed, and then **[Station list]** is displayed.

Scan DAB+ radio stations automatically

You can perform full scan to search for DAB+ radio stations.

- 1 In DAB+ mode, press **MODE/SCAN**.
 - ↳ The unit scans all available DAB+ radio stations and broadcasts the first available station.

Tune to DAB+ radio station manually

- 1 Press **DAB/TUNER** repeatedly to select **[DAB+]**.
- 2 Press **◀▶▶▶** to select **[Manual Tune]**.
- 3 Press **ENTER** to confirm.

- 4 Press **◀▶▶▶** to navigate DAB+ radio stations.
- 5 Press **ENTER** to confirm.

Program DAB+ radio stations manually

You can program a maximum of 30 preset DAB+ radio stations.

- 1 Tune to a DAB+ radio station.
- 2 Press **PRESET +/-** to select a preset number.
- 3 Press and hold **PROG/CLOCK SET** for two seconds.
 - ↳ The preset number of the saved station appears.

Listen to a preset DAB+ radio station

- 1 Press **SOURCE** repeatedly to select **[DAB+]**.
- 2 Press **PRESET +/-** to select a preset number.
- 3 Press **ENTER** to confirm.

Show DAB+ information

- 1 Tune to a DAB+ radio station.
- 2 Press repeatedly to scroll through the following information (if available):
 - ↳ Dynamic label segment (DLS)
 - ↳ Program type (PTY)
 - ↳ Ensemble Name
 - ↳ Time
 - ↳ Channel and frequency
 - ↳ Bit rate and audio status
 - ↳ Signal error rate

Use DAB+ menu

- 1 In the DAB+ mode, press **MENU** to enter the DAB+ menu.

2 Press **◀◀▶▶** to scroll the menu options:

- **[Station list]**
- **[Full scan]**
- **[Manual tune]**
- **[DRC] (dynamic range control)**
- **[Prune]**
- **[System]**

3 To select an option, press **ENTER**.

4 Repeat step 2-3 if sub-option is available under one option.

Full scan

Full scan is used to perform a wide range of DAB+ radio search.

- 1 In the DAB+ mode, press **MENU** to enter the menu options.
- 2 Press **◀◀▶▶** repeatedly until **[Full scan]** is displayed.
- 3 Press **ENTER** to confirm the selection.
↳ Full scan starts automatically.

Manual tune

With this feature, you can tune to a specific channel/frequency manually. In addition to antenna orientation for better radio reception, the optimal reception can also be obtained with this feature.

- 1 In the DAB+ mode, press **MENU** to display the "Manual tune" option.
- 2 Press **ENTER** to confirm the selection.
↳ The display shows a channel and its frequency.
- 3 Press **◀◀▶▶** repeatedly until the desired channel/frequency appears.
- 4 Press **ENTER** to confirm the selection.



Tip

- You may press **DISPLAY** to change the service information on the display.
 - You may adjust the position of the antenna to obtain the optimal signal strength.
- Press **MENU** to exit manual tune function.

DRC

Dynamic range control (DRC) adds or removes a degree of compensation for the differences in the dynamic range between radio stations.

- **[DRC off]** (DRC is switched off.)
- **[DRC high]** (DRC is switched on; the default setting recommended for noisy environment.)
- **[DRC low]** (DRC is set to half normal level)

Prune

With this feature, you can clear all the invalid stations from the station list.

- 1 In the DAB+ mode, press **MENU** to enter the menu options.
- 2 Press **◀◀▶▶** repeatedly until **[Prune]** is displayed.
- 3 Press **ENTER** to confirm the selection.
↳ **[Y]** or **[N]** is displayed.
- 4 Press **◀◀▶▶** to switch between **[Y]** and **[N]**.
- 5 Press **ENTER** to confirm.

System

With this feature, you can:

- **know the software version of the unit**
- 1 In the DAB+ mode, press **MENU** to enter the menu options.
 - 2 Press **◀◀▶▶** repeatedly until **[System]** is displayed.
 - 3 Press **ENTER** to confirm.
↳ **[SW version]** is displayed.
 - 4 Press **ENTER** again.
↳ The software version of the main unit is displayed.
- **reset DAB/FM stations**
- 1 In the DAB+ mode, press **MENU** to enter the menu options.
 - 2 Press **◀◀▶▶** repeatedly until **[System]** is displayed.
 - 3 Press **ENTER** to confirm.
↳ **[SW version]** is displayed.

- 4 Press **◀▶▶▶** to switch to **[Tuner Reset]**.
- 5 Press **ENTER** to confirm.
- 6 Press **◀▶▶▶** to switch between **[Y]** and **[N]**.
 - **[Y]**: reset all DAB/FM radio stations.
 - **[N]**: preset radio stations remain unchanged.
- 7 Press **ENTER** to confirm.

Listen to FM radio

Tune to a radio station

- 1 Press **TUNER** to select FM.
- 2 Press **◀▶▶▶** to tune to a specific frequency.
 - ↳ Play starts automatically.



Tip

- You can press **MODE/SCAN** to tune to the next station with strong reception automatically.

Program radio stations automatically

You can program a maximum of 30 preset radio stations (FM).

- 1 In the tuner mode, press and hold **MODE/SCAN** to activate automatic program mode.
 - ↳ All available stations are programmed in the order of waveband reception strength.
 - ↳ The first programmed radio station is broadcast automatically.

Program radio stations manually

You can program a maximum of 30 preset radio stations (FM).

- 1 Tune to a radio station.

- 2 Press **PROG/CLOCK SET** to activate program mode.
- 3 Press **▲▼** to allocate a number to this radio station, then press and hold **PROG/CLOCK SET** to confirm.
- 4 Repeat the above steps to program other stations.



Tip

- To overwrite a programmed station, store another station in its place.

Select a preset radio station

- 1 In tuner mode, press **▲▼** to select a preset number.
- 2 Press **▶■/ENTER** to confirm.
 - You can also press the numeric buttons to select a preset number directly.
 - You can press **▶■/ENTER** to switch between mono and stereo signals.



Tip

- Position the antenna as far as possible from TV, VCR or other radiation source.
- For optimal reception, fully extend and adjust the position of the antenna.

6 Play options

Pause/resume play

- 1 During play, press **▶||** to pause/resume play.

Skip to a track

For CD:

- 1 Press **◀◀▶▶** to select another track.
 - To select a track directly, you can also press a key on the numerical keypad.

For MP3 disc and USB:

- 1 Press **▲▼** to select an album or a folder.
- 2 Press **◀◀▶▶** to select a track or a file.

Search within a track

- 1 During play, press and hold **◀◀▶▶**.
- 2 Release to resume normal play.

Select repeat/shuffle play options

- 1 During play, press **MODE/SCAN** repeatedly to select a repeat option or the shuffle play mode.
 - **[▶ONE]**: the current track is played repeatedly.
 - **[▶ALB]**: all tracks in the current album are played repeatedly.
 - **[▶ALL]**: all tracks are played repeatedly.
 - **[▶SHUF]**: all tracks are played randomly.

- 2 To resume normal play, press **MODE/SCAN** repeatedly until no option is displayed.

Program tracks

Note

- You can program tracks only when the play stops.

You can program a maximum of 40 tracks.

- 1 Press **PROG/CLOCK SET** to activate the program mode.
↳ **[P]** is displayed.
- 2 For MP3/WMA tracks, press **▲▼** to select an album.
- 3 Press **◀◀▶▶** to select a track, then press **PROG/CLOCK SET** to confirm.
- 4 Repeat steps 2 to 3 to program more tracks.
- 5 Press **▶||** to play the programmed tracks.
↳ During play, **[P]** is displayed.
 - To erase the program, in the stop position, press **■**.

Display time

- 1 Press **DISPLAY** to display time.

Tip

- In Eco Standby mode, time is displayed for 90 seconds.

Adjust volume level

- 1 During play, press **VOL +/-** to increase/decrease the volume level.

Mute sound

- 1 During play, press **M** to mute/unmute sound.

Select a preset sound effect

- 1 During play, press **DSC** repeatedly to select:
 - **[POP]** (pop)
 - **[JAZZ]** (jazz)
 - **[ROCK]** (rock)
 - **[CLASSIC]** (classic)
 - **[FLAT]** (flat - all equalizers off)

Enhance bass

- 1 During play, press **DBB** to turn on or off dynamic bass enhancement.
 - ↳ If DBB is activated, **[DBB]** is displayed.

7 Other features

Set the alarm timer

This unit can be used as an alarm clock. The disc/radio/USB/iPod is activated to play at a preset time.

Note

- Ensure that you have set the clock correctly.

- 1 Press **⏻** to switch to standby mode.
- 2 Press and hold **SLEEP/TIMER** for more than two seconds.
 - ↳ A prompt to select the source is displayed.
- 3 Press **CD**, **iPod**, **TUNER**, **DAB**, or **USB** to select a source.
- 4 Press **SLEEP/TIMER** to confirm.
 - ↳ The clock digits are displayed.
 - ↳ The hour digits begin to blink.
- 5 Press **⏮**/**⏭** to set the hour.
- 6 Press **SLEEP/TIMER** to confirm.
 - ↳ The minute digits begin to blink.
- 7 Press **⏮**/**⏭** to set the minute.
 - ↳ The timer is set and activated.
 - ↳ **⌚** is displayed.

Set the sleep timer

This unit can switch to standby automatically after a set period of time.

- 1 When the unit is turned on, press **SLEEP/TIMER** repeatedly to select a set period of time (in minutes).
 - ↳ When sleep timer is activated, **zZ** is displayed.

To deactivate sleep timer

- 1 Press **SLEEP/TIMER** repeatedly until **[OFF]** (off) is displayed.
 - ↳ When sleep timer is deactivated, **zZ** disappears on the display.

Play from an external device

You can also listen to an external audio device through this unit.

- 1 Press **USB/MP3 LINK** to select the MP3 link source.
- 2 Connect the supplied MP3 link cable to:
 - the **MP3 LINK** jack (3.5mm) on the unit.
 - the headphone jack on an external device.
- 3 Start to play the device (see the device user manual).

Listen through headphone

- 1 Plug a headphone into the **🎧** socket on the unit.

8 Product information



Note

- Product information is subject to change without prior notice.

Specifications

Amplifier

Total output power	2 × 10 W RMS
Frequency response	80 Hz - 16 kHz, ± 3 dB
Signal to noise ratio	> 60 dB
MP3 link input	0.5 V RMS 20 kΩ

Disc

Laser type	Semiconductor
Disc diameter	12 cm / 8 cm
Support disc	CD-DA, CD-R, CD-RW, MP3-CD, WMA-CD
Audio DAC	24 Bits / 44.1 kHz
Total harmonic distortion	< 1.5%
Frequency response	60 Hz -16 kHz (44.1 kHz)
Signal to noise ratio	> 55 dBA

Tuner

Tuning Range	FM: 87.5 - 108MHz DAB: 174.92 - 239.20 MHz
Tuning grid (FM)	50 KHz
Sensitivity	- Mono, 26dB S/N Ratio < 22 dBf - Stereo, 46dB S/N Ratio > 43 dBf
Search Selectivity	< 28 dBf
Total Harmonic Distortion	< 2%
Signal to Noise Ratio	>55 dB
Number of presets	30 (FM) 30 (DAB)

Speakers

Speaker impedance	2 × 10 W, 4 Ω
-------------------	---------------

General information

AC power	100 - 240V~, 50/60Hz
Operation Power	
Consumption	15 W
Standby Power	
Consumption	< 2 W
Eco Power Standby	
Power Consumption	< 1 W
USB Direct	Version 2.0/1.1
Dimensions	
- Main Unit (W × H × D)	565 × 245 × 104 mm
Weight	
- Main Unit	2.7 kg

USB playability information

Compatible USB devices:

- USB flash memory (USB 2.0 or USB 1.1)
- USB flash players (USB 2.0 or USB 1.1)
- memory cards (requires an additional card reader to work with this unit)

Supported formats:

- USB or memory file format FAT12, FAT16, FAT32 (sector size: 512 bytes)
- MP3 bit rate (data rate): 32-320 Kbps and variable bit rate
- WMA v9 or earlier
- Directory nesting up to a maximum of 8 levels
- Number of albums/ folders: maximum 99
- Number of tracks/titles: maximum 999
- ID3 tag v2.0 to v2.3
- File name in Unicode UTF8 (maximum length: 128 bytes)

Supported MP3 disc formats

- ISO9660, Joliet
- Maximum title number: 999 (depending on file name length)
- Maximum album number: 99
- Supported sampling frequencies: 32 kHz, 44.1kHz, 48 kHz
- Supported Bit-rates: 32-320 (kbps), variable bit rates
- ID3 tag v2.0 to v2.3
- Directory nesting up to a maximum of 8 levels

Maintenance

Clean the cabinet

- Use a soft cloth slightly moistened with a mild detergent solution. Do not use a solution containing alcohol, spirits, ammonia or abrasives.

Clean discs

- When a disc becomes dirty, clean it with a cleaning cloth. Wipe the disc from the centre out.

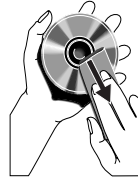

- Do not use solvents such as benzene, thinner, commercially available cleaners, or antistatic spray intended for analogue records.

Clean the disc lens

- After prolonged use, dirt or dust may accumulate at the disc lens. To ensure good play quality, clean the disc lens with Philips CD lens cleaner or any commercially available cleaner. Follow the instructions supplied with cleaner.

9 Troubleshooting



Warning

- Never remove the casing of this apparatus.

To keep the warranty valid, never try to repair the system yourself.

If you encounter problems when using this apparatus, check the following points before requesting service. If the problem remains unsolved, go to the Philips web site (www.philips.com/welcome). When you contact Philips, ensure that the apparatus is nearby and the model number and serial number are available.

No power

- Ensure that the AC power plug of the unit is connected properly.
- Ensure that there is power at the AC outlet.
- To save power, the unit switches to Eco Standby mode automatically after 15 minutes in standby mode.

No sound

- Adjust the volume.

No response from the unit

- Disconnect and reconnect the AC power plug, then turn on the unit again.

No disc detected

- Insert a disc.
- Check if the disc is inserted with the print side facing inward.
- Wait until the moisture condensation at the lens has cleared.
- Replace or clean the disc.
- Use a finalized CD or correct format disc.

Remote control does not work

- Before pressing any function button, first select the correct source with the remote control instead of the main unit.
- Reduce the distance between the remote control and the unit.
- Insert the battery with its polarities (+/- signs) aligned as indicated.
- Replace the battery.
- Aim the remote control directly at the sensor on the front of the unit.

Cannot display some files in USB device

- The number of folders or files in the USB device has exceeded a certain limit. This phenomenon is not a malfunction.
- The formats of these files are not supported.

USB device not supported

- The USB device is incompatible with the unit. Try another one.

Poor radio reception

- Increase the distance between the unit and your TV or VCR.
- Fully extend the DAB/FM antenna.

Clock/timer setting erased

- Power has been interrupted or the power cord has been disconnected.
- Reset the clock/timer.

Timer does not work

- Set the clock correctly.
- Switch on the timer.



sense and simplicity

**PHILIPS CONSUMER ELECTRONICS
WARRANTY POLICY FOR AUSTRALIA**

Effective 1st July 2009

Philips provides its Consumer Electronics products with a 1 Year Manufacturers Warranty.

The benefits given to the purchaser by this warranty are in addition to all other rights and remedies, which the purchaser has in respect of the product under the Trade Practices Act or other Commonwealth or State Law.

The conditions contained in this warranty replace and override the provision of the Philips World-Wide Guarantee for products purchased in Australia and used in Australia.

Please record the following information for your records and keep in a safe place. It is essential that you retain your original purchase receipt to make a warranty claim.

Model number	:
Serial number	:
Date of purchase	:
Retailer	:

If you require assistance with the operation of the product, its features or specifications, you may call the **Philips Technology Care Centre on 1300 363 391** where support is provided by our trained staff.

If the product fails within 12 months from the date of purchase, please return the faulty product to the place of purchase.

Conditions of Warranty

- a. All claims for warranty can only be made at the place of purchase and a copy of the purchase receipt is required for any warranty claim.
- b. The warranty period is valid from the original date of purchase of the product.
- c. This warranty extends only to defects in material or workmanship occurring under normal use of the product when operated in accordance with the instructions.
- d. Philips may, at its discretion choose to repair rather than replace this product.
- e. If a replacement product is supplied, it is warranted for the remainder of the warranty period, from the original date of purchase.
- f. This Manufacturers Warranty is limited to 3 months for products used in commercial applications.
- g. Product accessories are covered by the same warranty period. If an accessory is faulty, please contact the Philips Technology Care Centre on **1300 363 391**.
- h. This Manufacturers Warranty is neither transferable nor valid in countries other than Australia.

This Warranty does not cover:

- a. Service costs arising from failure to correctly adjust the controls of the product or to observe the instructions, or inspections that reveal that the product is in normal working order.
- b. Product failures caused by misuse, neglect, accidental breakage, transit damage, un-authorized repairs or modification by un-authorized persons, external fires, lightning strikes, floods, vermin infestation or liquid spillage.
- c. Reception problems, replacement of worn or used batteries or other consumables.
- d. Second hand products or refurbished products.
- e. Products failure, caused by other products.

New Zealand - Guarantee and Service for New Zealand

Thank-you for purchasing this quality Philips product.

Philips New Zealand Ltd guarantees this product against defective components and faulty workmanship for a period of 12 months. Any defect in materials or workmanship occurring within 12 months from the date of purchase subject to the following conditions will be rectified free of charge by the retailer from whom this product was purchased.

Conditions

1. The product must have been purchased in New Zealand. As proof of purchase, retain the original sales docket indicating the date of purchase.
2. The guarantee applies only to faults caused by defective components, or faulty workmanship on the part of the manufacturer.
3. The guarantee does not cover failures caused by misuse, neglect, normal wear and tear, accidental breakage, use on the incorrect voltage, use contrary to operating instructions, or unauthorised modification to the product or repair by an unauthorised technician.
4. Reasonable evidence (in the form of a sales docket) must be supplied to indicate that the product was purchased no more than 12 months prior to the date of your claim.
5. In the event of a failure, Philips shall be under no liability for any injury, or any loss or damage caused to property or products other than the product under guarantee.

This guarantee does not prejudice your rights under common law and statute, and is in addition to the normal responsibilities of the retailer and Philips.

How to claim

Should your Philips product fail within the guarantee period, please return it to the retailer from whom it was purchased. In most cases the retailer will be able to satisfactorily repair or replace the product.

However, should the retailer not be able to conclude the matter satisfactorily, or if you have other difficulties claiming under this guarantee, please contact

The Guarantee Controller Philips New Zealand Ltd.

✉ P.O. Box 41.021

Auckland

☎ (09) 84 94 160

fax ☎ (09) 84 97 858

