

Always there to help you  
Register your product and get support at  
[www.philips.com/support](http://www.philips.com/support)



## Short User Manual

**PHILIPS**

FXD58

### Important

#### Safety

##### Know these safety symbols



This 'bolt of lightning' indicates uninsulated material within your unit may cause an electrical shock. For the safety of everyone in your household, please do not remove product covering.

The 'exclamation mark' calls attention to features for which you should read the enclosed literature closely to prevent operating and maintenance problems.

**WARNING:** To reduce the risk of fire or electric shock, this apparatus should not be exposed to rain or moisture and objects filled with liquids, such as vases, should not be placed on this apparatus.

**CAUTION:** To prevent electric shock, match wide blade of plug to wide slot, and fully insert the plug.

##### Important Safety Instructions

- 1 Read these instructions.
- 2 Keep these instructions.
- 3 Heed all warnings.
- 4 Follow all instructions.
- 5 Do not use this apparatus near water.
- 6 Clean only with dry cloth.
- 7 Do not block any ventilation openings. Install in accordance with the manufacturer's instructions.
- 8 Do not install near any heat sources such as radiators, heat registers, stoves, or other apparatus (including amplifiers) that produce heat.
- 9 Protect the power cord from being walked on or pinched, particularly at plugs, convenience receptacles, and the point where they exit from the apparatus.
- 10 Only use attachments/accessories specified by the manufacturer.
- 11 Use only with the cart, stand, tripod, bracket, or table specified by the manufacturer or sold with the apparatus. When a cart is used, use caution when moving the cart/apparatus combination to avoid injury from tip-over.



- 12 Unplug this apparatus during lightning storms or when unused for long periods of time.
- 13 Refer all servicing to qualified service personnel. Servicing is required when the apparatus has been damaged in any way, such as power-supply cord or plug is damaged, liquid has been spilled or objects have fallen into the apparatus, the apparatus has been exposed to rain or moisture, does not operate normally, or has been dropped.
- 14 Battery usage **CAUTION** – To prevent battery leakage which may result in bodily injury, property damage, or damage to the unit:
  - Install all batteries correctly, + and - as marked on the unit.
  - Do not mix batteries (old and new or carbon and alkaline, etc.).
  - Remove batteries when the unit is not used for a long time.

- 15 Apparatus shall not be exposed to dripping or splashing.
- 16 Do not place any sources of danger on the apparatus (e.g. liquid filled objects, lighted candles).
- 17 Where the MAINS plug or an appliance coupler is used as the disconnect device, the disconnect device shall remain readily operable.

Risk of overheating! Never install this apparatus in a confined space. Always leave a space of at least four inches around this apparatus for ventilation. Ensure curtains or other objects never cover the ventilation slots on this apparatus.

#### Caution

- Use of controls or adjustments or performance of procedures other than herein may result in hazardous radiation exposure or other unsafe operation.

#### Warning

- Never remove the casing of this unit.
- Never lubricate any part of this unit.
- Place this unit on a flat, hard and stable surface.
- Never place this unit on other electrical equipment.
- Only use this unit indoors. Keep this unit away from water, moisture and liquid-filled objects.
- Keep this unit away from direct sunlight, naked flames or heat.
- Never look into the laser beam inside the unit.

#### Notice

Any changes or modifications made to this device that are not expressly approved by WOOX Innovations may void the user's authority to operate the equipment.

Specifications are subject to change without notice. WOOX reserves the right to change products at any time without being obliged to adjust earlier supplies accordingly.

#### Disposal of your old product and batteries

Your product is designed and manufactured with high quality materials and components, which can be recycled and reused. Never dispose of your product with other household waste. Please inform yourself about the local rules on the separate collection of electrical and electronic products and batteries. The correct disposal of these products helps prevent potentially negative consequences on the environment and human health.

Your product contains batteries, which cannot be disposed of with normal household waste.

Please inform yourself about the local rules on separate collection of batteries. The correct disposal of batteries helps prevent potentially negative consequences on the environment and human health.

Please visit [www.recycle.philips.com](http://www.recycle.philips.com) for additional information on a recycling center in your area.

#### Information about the use of batteries:

#### Caution

- Risk of leakage: Only use the specified type of batteries. Do not mix new and used batteries. Do not mix different brands of batteries. Observe correct polarity. Remove batteries from products that are not in use for a longer period of time. Store batteries in a dry place.
- Risk of injury: Wear gloves when handling leaking batteries. Keep batteries out of reach of children and pets.
- Risk of explosion: Do not short circuit batteries. Do not expose batteries to excessive heat. Do not throw batteries into the fire. Do not damage or disassemble batteries. Do not recharge non-rechargeable batteries.

#### Environmental information

All unnecessary packaging has been omitted. We have tried to make the packaging easy to separate into three materials: cardboard (box), polystyrene foam (buffer) and polyethylene (bags, protective foam sheet).

Your system consists of materials which can be recycled and reused if disassembled by a specialized company. Please observe the local regulations regarding the disposal of packaging materials, exhausted batteries and old equipment.

#### Copyright notice

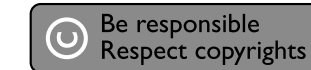

This item incorporates copy protection technology that is protected by U.S. patents and other intellectual property rights of Rovi Corporation. Reverse engineering and disassembly are prohibited.

#### Trademark notice

Philips and the Philips' Shield Emblem are registered trademarks of Koninklijke Philips N.V. and are used by WOOX Innovations Limited under license from Koninklijke Philips N.V.

Manufactured under license from Dolby Laboratories. Dolby and the double-D symbol are trademarks of Dolby Laboratories.

DivX®, DivX Ultra®, DivX Certified® and associated logos are trademarks of Rovi Corporation or its subsidiaries and are used under license.

DivX Ultra® Certified to play DivX® video with advanced features and premium content. ABOUT DIVX-VIDEO: DivX® is a digital video format created by DivX, LLC, a subsidiary of Rovi Corporation. This is an official DivX Certified® device that plays DivX video. Visit [divx.com](http://divx.com) for more information and software tools to convert your files into DivX videos.

ABOUT DIVX-VIDEO-ON-DEMAND: This DivX Certified® device must be registered in order to play purchased DivX Video-on-Demand (VOD) movies. To obtain your registration code, locate the DivX VOD section in your device setup menu. Go to [vod.divx.com](http://vod.divx.com) for more information on how to complete your registration.

'DVD Video' is a trademark of DVD Format/Logo Licensing Corporation.

HDMI and HDMI logo, and High-Definition Multimedia Interface are trademarks or registered trademarks of HDMI Licensing LLC in the United States and other countries.

The Bluetooth® word mark and logos are registered trademarks owned by Bluetooth SIG, Inc. and any use of such marks by WOOX Innovations is under license.

Other trademarks and trade names are those of their respective owners.

The N Mark is a trademark or registered trademark of NFC Forum, Inc. in the United States and in other countries.

#### This apparatus includes this label:



#### Note

- The type plate is located on the back of the unit.

#### Specifications

Amplifier	
Rated Output Power	240W x 2 + 240W RMS
Frequency Response	20 Hz-20 kHz / ±3 dB
Signal to Noise Ratio	≥ 65 dBA
AUDIO Input	1V RMS 22k ohm

Disc	
Laser Type	Semiconductor
Disc Diameter	12 cm/8 cm
Video Decoding	MPEG-1 / MPEG-2 / DivX
Video DAC	12 Bits
Signal System	PAL / NTSC
Video Format	4:3 / 16:9
Video Luminance S/N	> 55 dB
Audio DAC	24 Bits / 96 kHz
Total Harmonic Distortion	≤ 1% (1 kHz)

Tuner (FM)	
Tuning Range	87.5 - 108 MHz
Tuning grid	50 KHz
Sensitivity - Mono, 26dB S/N Ratio	< 22 dBf
Total Harmonic Distortion	< 3%
Signal to Noise Ratio	> 50dB

Speakers	
Speaker Impedance	3 ohm
Speaker Driver	5.25 inch woofer*2 + 2 inch tweeter*2 + 8 inch subwoofer*1
Sensitivity	84dB/1M/1W

Bluetooth	
Bluetooth version	V2.1 + EDR
Frequency band	2.4GHz ~ 2.48GHz ISM Band
Range	10m (free space)

General information	
AC power	110-240V ~ 50-60 Hz
Operation Power Consumption	130 W
Standby Power Consumption	< 0.5 W
Composite Video Output	1.0Vp-p, 75 ohm
USB Direct	Version 2.0

Dimensions	
- Main Unit (W x H x D)	467 X 140 X 320 mm
- Speaker (W x H x D)	204 X 309 X 145 mm
- Subwoofer (W x H x D)	299 X 308 X 248 mm
Weight	
- Main Unit	3.35 kg
- Speaker Box	2 x 2.2 kg
- Subwoofer	4.9 kg

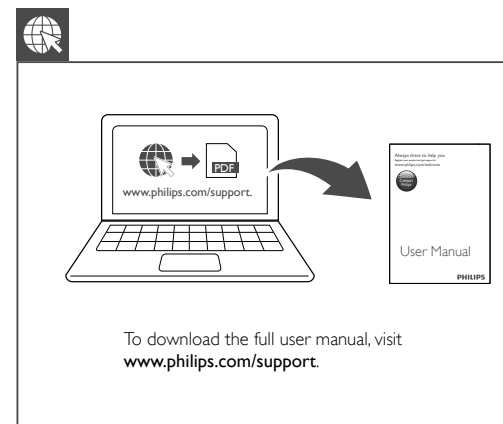
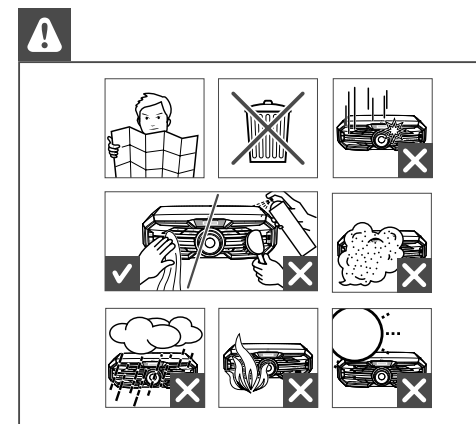

2014 © WOOX Innovations Limited. All rights reserved. Philips and the Philips' Shield Emblem are registered trademarks of Koninklijke Philips N.V. and are used by WOOX Innovations Limited under license from Koninklijke Philips N.V.

FXD58\_98\_Short User Manual\_V3.0

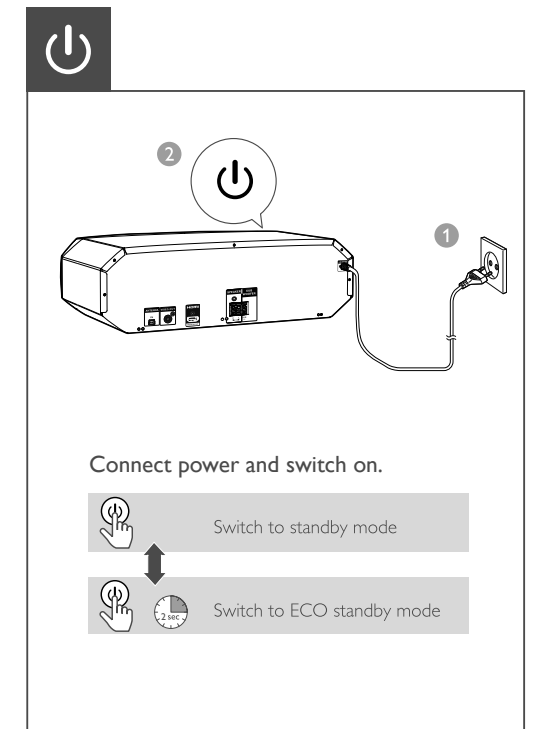
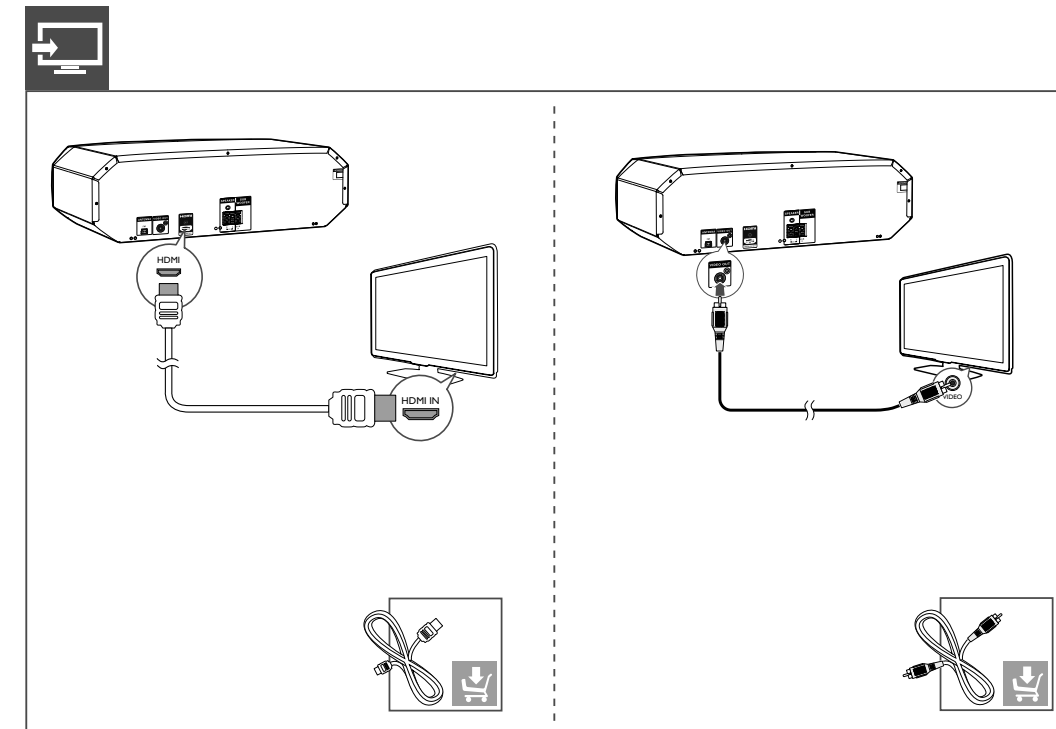
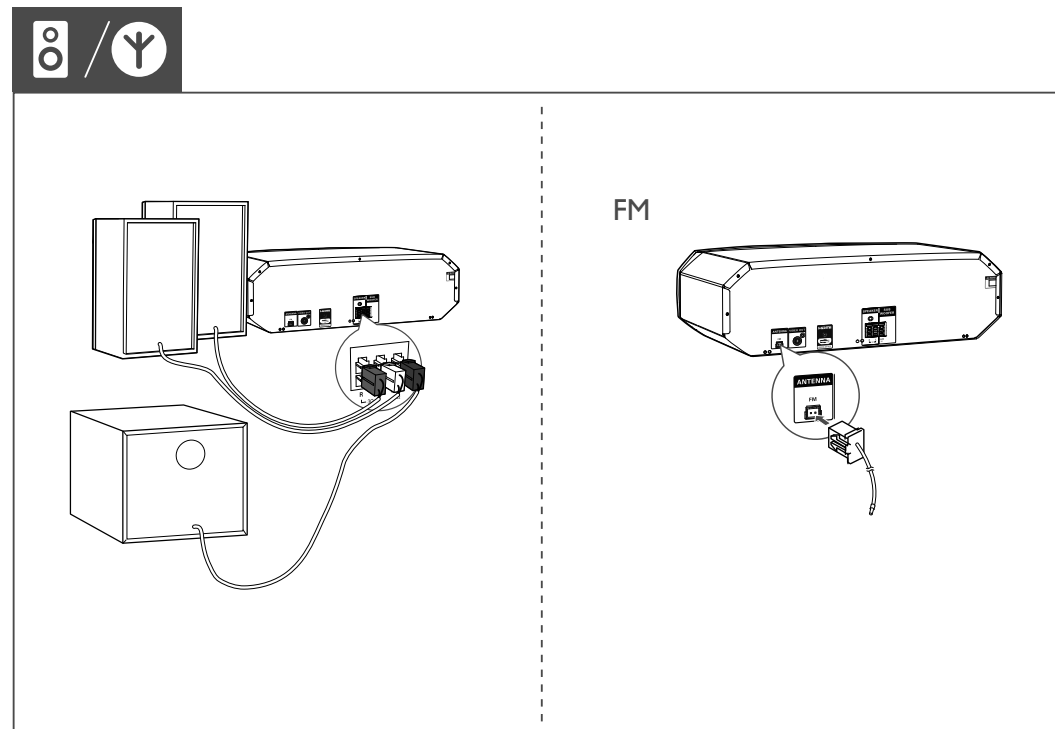
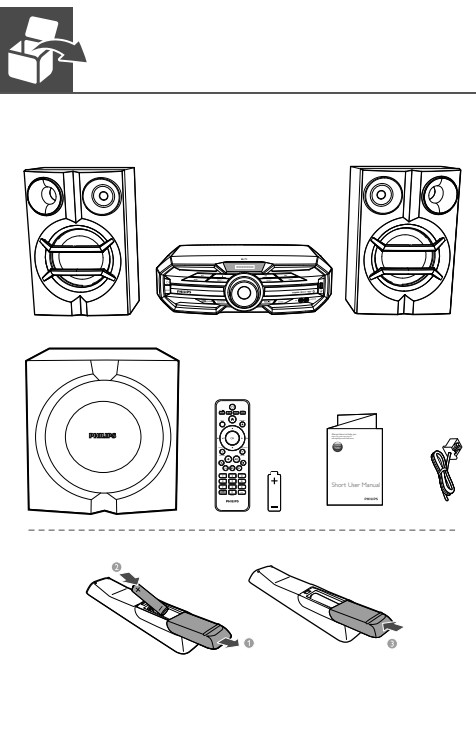

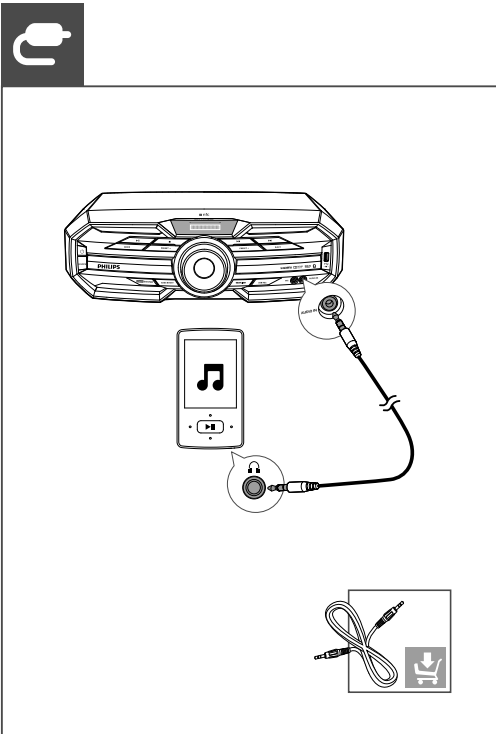

**PHILIPS**

1 — [Power] SOURCE

2 — [TV] SOURCE

3 — [Power] PHILIPS

4 — DISC PHILIPS

5 — [Power] PHILIPS

General	Audio	English
Video	Subtitle	Off
Audio	Disc Menu	English
Preference	Parental Control	8 Adult
	PBC	On
	Password	Change
	DivX Subtitle	Standard
	Version Info	

General	Disc Lock	*Unlock
Video	Display Dim	100%
Audio	OSD Language	English
Preference	Stop Time	Off
	Auto Standby	On
	DivX(R) VOD Code	*Registration

**PHILIPS**

General	Audio	English
Video	Subtitle	Off
Audio	Disc Menu	English
Preference	Parental Control	8 Adult
	PBC	On
	Password	Change
	DivX Subtitle	Standard
	Version Info	

General	Audio	Off
Video	Subtitle	English
Audio	Disc Menu	Chinese
Preference	Parental Control	French
	PBC	Spanish
	Password	Portuguese
	DivX Subtitle	Polish
	Version Info	Italian

Karaoke	Microphone	Off
	Mic Volume	
	Echo Level	
	Karaoke Scoring	Off
	Karaoke Kdol	Off
	Key Shift	
	Vocal	No Vocal

**BT**

1 SOURCE

2 Bluetooth

3 A Bluetooth Devices Philips FXD58

3 B NFC

4 Bluetooth

10 m

Press **SOURCE** repeatedly to select the Bluetooth source.  
 ↳ 'BT' (Bluetooth) is displayed on the screen.

1 Enable Bluetooth on your mobile device.  
 2 A Search for Bluetooth devices that can be paired, then select 'Philips MINI FXD58' to start pairing and connection.  
 B Or, enable the NFC feature on your Bluetooth device, then touch the NFC area of the external device with the NFC area on the top of the unit.  
 ↳ After successful pairing and connection, 'BT CONNECTED' (Bluetooth connected) scrolls on the screen once.  
 3 Play music on your Bluetooth-enabled device through the unit.

Button	Function
[Mute]	Mute or resume sound.
[Volume +/-]	Increase or decrease volume.
[MAX SOUND]	Turn on or off instant power boost for sound.
[EQ]	Select a preset sound equalizer setting: JAZZ, ROCK, TECHNO, POP or SAMBA.

**REC**

1 2 3 4

1 Load a CDDA disc onto the disc tray and close the disc compartment.  
 2 Insert a USB device into the USB socket on the front panel.  
 3 Press **USB REC** to enter the home page with **MP3** highlighted.  
 4 Press **OK** to enter the recording menu and follow on-screen instructions to continue.

**DISC**

1 2

**USB**

1 2

In DISC/USB mode, access or exit the home menu.  
 ▲ / ▼ Navigate up/down in a menu. Rotate a picture. During video play, select a slow backward/forward mode.  
 ◀ / ▶ (◀ / ▶) Search in a track or disc. Navigate left/right in a menu. Tune to a radio station.  
 ≡ **OPTIONS (MODE)** Access more play options while playing a disc or a USB storage device. Select a repeat play mode.

■ Stop play or erase a program.  
 ◀ / ▶ Skip to the previous/next track, title, or chapter. In radio mode, select a preset radio station.  
 || Start or pause play.  
 ↶ **BACK (ID3/INFO)** Return to the previous menu. For discs, access the play options or display the current disc status. For slideshow, display a thumbnail view of photo files. For MP3 discs, display ID3 information if available.  
 OK Confirm an operation or selection.

**87.50**

1 2

**87.50**

**AUTO**

**87.50**

**P 01**

**P 02**

**Store radio stations manually**  
 1 Tune to a radio station.  
 2 Press ≡ **OPTIONS (MODE)** to activate program mode.  
 3 Press ▲ / ▼ to allocate a preset number then press ≡ **OPTIONS (MODE)** to confirm.  
 4 Repeat the above three steps to store more stations.

**Store radio stations automatically**  
 1 Press and hold ≡ **OPTIONS (MODE)** to activate automatic program mode.  
 2 Press ▲ / ▼ to select preset stations.