

User manual



Need help? Call us!
 Philips representatives are ready to help you with any questions about your new product.
CALL US BEFORE YOU CONSIDER RETURNING THE PRODUCT!
1-888-PHILIPS(1-888-744-5477)
 or visit us on the web at www.philips.com



PHILIPS

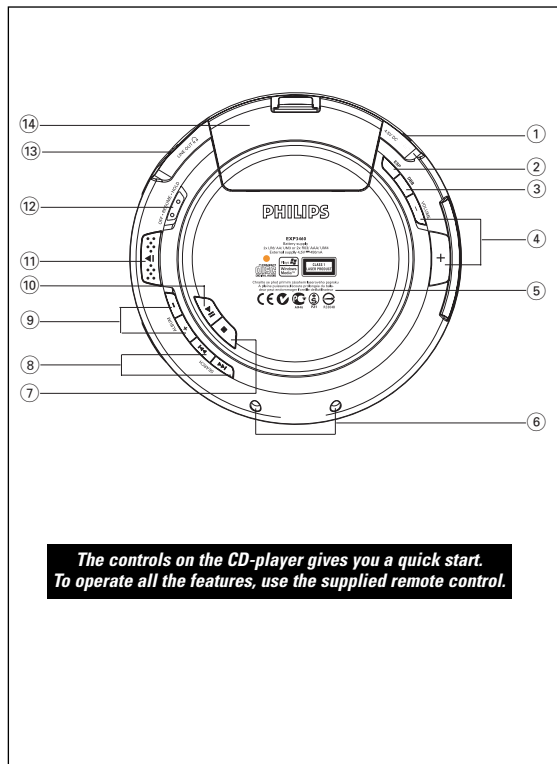

The controls on the CD-player gives you a quick start. To operate all the features, use the supplied remote control.

PHILIPS CONSUMER ELECTRONICS NORTH AMERICA

Knoxville, Tennessee 37914-1810, U.S.A.

Meet Philips at the Internet
<http://www.philips.com>



EXP3461

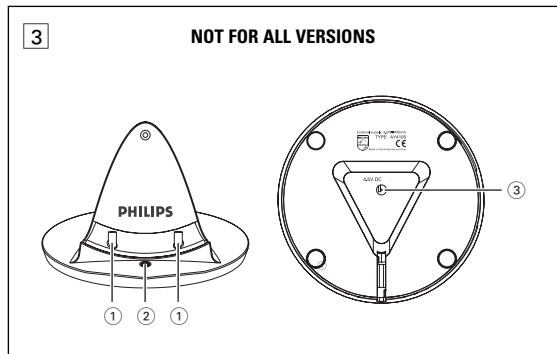
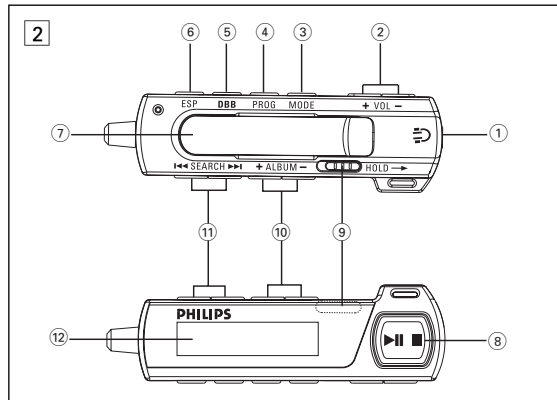

Printed in China

LC/bk WK0446

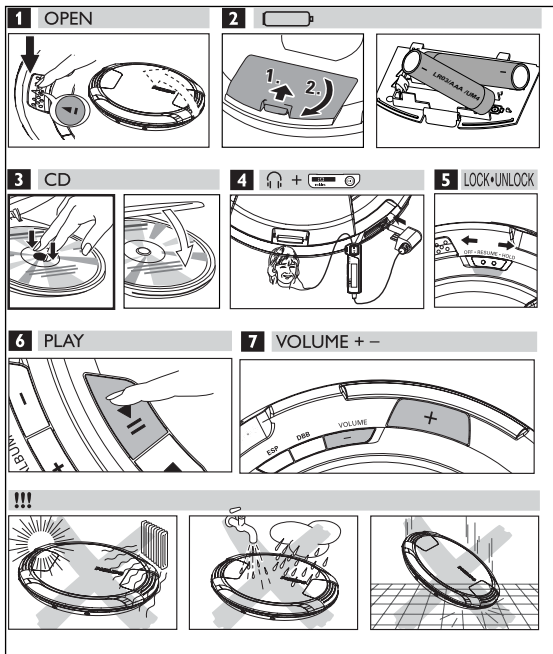

Return your Product Registration Card today to get the very most from your purchase.

Registering your model with PHILIPS makes you eligible for all of the valuable benefits listed below, so don't miss out. Complete and return your Product Registration Card at once to ensure:

***Proof of Purchase**

Returning the enclosed card guarantees that your date of purchase will be on file, so no additional paperwork will be required from you to obtain warranty service.

***Product Safety Notification**

By registering your product, you'll receive notification - directly from the manufacturer - in the rare case of a product recall or safety defect.

***Additional Benefits of Product Ownership**

Registering your product guarantees that you'll receive all of the privileges to which you're entitled, including special money-saving offers.

Know these safety symbols



This "bolt of lightning" indicates uninsulated material within your unit may cause an electrical shock. For the safety of everyone in your household, please do not remove product covering.

The "exclamation point" calls attention to features for which you should read the enclosed literature closely to prevent operating and maintenance problems.

For Customer Use

Enter below the Serial No. which is located on the rear of the cabinet. Retain this information for future reference.

Model No. _____

Serial No. _____

WARNING: To reduce the risk of fire or electric shock, this apparatus should not be exposed to rain or moisture, and objects filled with liquids, such as vases, should not be placed on this apparatus.

CAUTION: To prevent electric shock, match wide blade of plug to wide slot, fully insert.

ATTENTION: Pour éviter les chocs électriques, introduire la lame la plus large de la fiche dans la borne correspondante de la prise et pousser jusqu'au fond.

IMPORTANT SAFETY INSTRUCTIONS

1. Read these instructions.
2. Keep these instructions.
3. Heed all warnings.
4. Follow all instructions.
5. Do not use this apparatus near water.
6. Clean only with a dry cloth.
7. Do not block any of the ventilation openings. Install in accordance with the manufacturers instructions.
8. Do not install near any heat sources such as radiators, heat registers, stoves, or other apparatus (including amplifiers) that produce heat.
9. Only use attachments/accessories specified by the manufacturer.
10.  Use only with a cart, stand, tripod, bracket, or table specified by the manufacturer or sold with the apparatus. When a cart is used, use caution when moving the cart/apparatus combination to avoid injury from tip-over.

11. Refer all servicing to qualified service personnel. Servicing is required when the apparatus has been damaged in any way, such as if the power-supply cord or plug is damaged, liquid has been spilled or objects have fallen into the apparatus, or when the apparatus has been exposed to rain or moisture, does not operate normally, or has been dropped.
12. Battery usage **CAUTION** – To prevent battery leakage which may result in bodily injury, property damage, or damage to the unit:
 - Install **ALL** batteries correctly, + and - as marked on the unit.
 - Do not mix batteries (**OLD** and **NEW** or **CARBON** and **ALKALINE**, etc.).
 - Remove batteries when the unit is not used for a long time.
13. Apparatus shall not be exposed to dripping or splashing.
14. Do not place any sources of danger on the apparatus. (e.g. liquid filled objects, lighted candles).
15. This product may contain lead and mercury. Disposal of these material may be regulated due to environment considerations. **For disposal or recycling information, please contact your local authorities or the Electronic Industries Alliance : www.eiae.org.**

EL 6475-E005: 04/01

Supplied Accessories:

- 1 x headphones HS383
- 1 x remote control, AY3802
- 1 x AAA battery door

Controls (see figure 1)



- ① **4.5V DC** jack for AC/DC adapter power supply
- ② **ESP** selects between the battery powersave mode and Electronic Skip Protection (ESP). ESP prevents playback interruptions caused by shocks.
- ③ **DBB** switches the bass enhancement on/off. When pressed for more than 2 seconds, the button switches audible feedback (beep) on/off.
- ④ **VOLUME +/-** adjusts the volume
- ⑤ typeplate
- ⑥ **■** stops playback/ clears programmed tracks / switches off the set.
- ⑦ **SEARCH << / >>**skips and searches backward/ forward tracks.
- ⑧ **ALBUM +/-**MP3/WMA- CD only: selects the next/previous album or skips forward/backward tracks.
- ⑨ **▶II** switches the player on, starts or pauses CD playback.
- ⑩ **▲** opens the CD lid
- ⑪ **OFF**switches RESUME and HOLD off (on the set only)
- RESUME**saves the last position played
- HOLD**locks all buttons (on the set only)
- ⑫  connect the remote control here and your headphones to the remote control
- ⑬ battery door

Remote control AY3802 (see figure 2)



- ① 3.5 mm headphone jack
- ② **VOL +/-**adjusts the volume
- ③ **MODE**selects playback options. To select and enter the display function, press and hold MODE for 3 seconds.
- ④ **PROG**programs tracks and reviews the program
- ⑤ **DBB**switches the bass enhancement on and off. When pressed for more than 2 seconds, the button switches audible feedback (beep) on/off.
- ⑥ **ESP**selects between the battery powersave mode and Electronic Skip Protection (ESP). ESP prevents playback interruptions caused by shocks.
- ⑦clip
- ⑧ **▶II**switches the player on, starts or pauses CD playback.
■stops CD playback, clears a program or switches the player off.
- ⑨ **OFF**switches HOLD off (on the remote control only)
- HOLD**locks all buttons (on the remote control only)
- ⑩ **ALBUM +/-**MP3/WMA-CD only: selects the previous or next album
- ⑪ **SEARCH << / >>**skips and searches backward/ forward tracks
- ⑫display

REMOTE CONTROL AY3802 / HEADPHONE HS 383**Using the remote control**

The remote control allows you to command all the functions on the player.

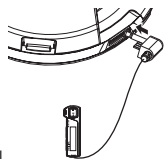
- 1 **Firmly connect the remote control to LINE OUT  on the set.**
- 2 **Firmly connect the headphones to the jack  on the remote control.**
- 3 On the remote control, press **▶II** to start playback.
- 4 Adjust the volume and sound on your remote control.
- 5 To stop playback, press **■**.
- 6 To switch off the CD player, press **■** again.

**Headphones HS383, LINE OUT**

- Connect the remote control to **LINE OUT  jack** of the player and your headphones to the remote control.
-  can also be used for connecting the player to your HiFi system.

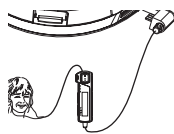
**IMPORTANT!**

Hearing safety: listen at a moderate volume. using headphones at high volume can impair your hearing.

Traffic safety: do not use headphones while driving or cycling as you may cause an accident.

CD PLAYER AND CD HANDLING

- Do not touch the lens (A) of the CD player.
- Do not expose the unit, batteries or CDs to humidity, rain, sand or excessive heat (caused by heating equipment or direct sunlight).
- You can clean the CD player with a soft, slightly dampened, lint-free cloth. Do not use any cleaning agents as they may have a corrosive effect.
- To clean the CD, wipe it in a straight line from the center toward the edge using a soft, lint-free cloth. A cleaning agent may damage the disc! Never write on a CD or attach a sticker to it.
- The lens may cloud over when the unit is moved suddenly from cold to warm surroundings. Playing a CD is not possible then. Leave the CD player in a warm environment until the moisture has evaporated.
- Active mobile phones in the vicinity of the CD player may cause malfunctions.
- Avoid dropping the unit as this may cause damage.

**CAUTION**

Use of controls or adjustments or performance of procedures other than herein may result in hazardous radiation exposure or other unsafe operation.

POWER SUPPLY

Batteries (supplied or optionally available)

You can use the following batteries with this CD-player:

- ◆ alkaline batteries type **AA (LR6, UM3)** or **AAA (LR03, UM4)**.
- ◆ PHILIPS rechargeable batteries, type **AY3363**

Inserting AA (LR6, UM3) batteries

- 1 Open the battery compartment.
- 2 Insert 2 x **AA** batteries as shown into the battery compartment.
- 3 Close the battery compartment.

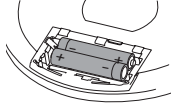

Inserting AAA (LR03, UM4) or AY 3363 batteries

- 1 Open the battery compartment.
- 2 Insert **AAA** batteries as shown onto the back of the AAA battery door.
- 3 Fit the **AAA** battery-loaded door onto the battery compartment.



Helpful Hints:

- Old and new or different types of batteries should not be combined.
- Remove batteries if they are empty or if the player is not going to be used for a long time.

POWER SUPPLY

Battery indication

The battery level is shown in the display screen as follows:

- Battery full
- Battery two-thirds full
- Battery one-third full
- Battery dead or empty. The display shows **LQW BATT** and the beep tone sounds repeatedly.

Average playing time of batteries under normal conditions

Battery type	Power Save	
	Audio CD	MP3-CD
Alkaline AA	30 hours	45 hours
Alkaline AAA	13 hours	20 hours

Batteries contain chemical substances, so they should be disposed of properly

- Apparatus shall not be exposed to dripping or splashing.
- Do not place any sources of danger on the apparatus (e.g. liquid filled objects, lighted candles)

POWER SUPPLY

AC/DC adapter AY3162 (supplied or optionally available)

Only use AY3162 adapter (4.5V/450mA DC, positive pole to the center pin). Any other product may damage the player.

- 1 Make sure the local voltage corresponds to the AC/DC adapter's voltage.
- 2 Connect the AC/DC adapter to the 4.5V DC jack of the player and to the wall outlet.

Helpful Hint:

- Always disconnect the adapter when you are not using it.

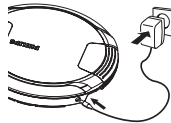

ABOUT MP3/ WMA

The music compression technology MP3 (MPEG1 Audio Layer 3) and WMA (Windows Media Audio) significantly reduce the digital data of an audio CD while maintaining CD quality sound.

- **Getting MP3/WMA files:** you can either download legal music files from the internet to your computer hard disc, or create such files by converting audio CD files in your computer through appropriate encoder software. (128kbps bit is recommended for MP3 files and 96 kbps bit rate for WMA files.)
- **Creating a MP3/WMA CD:** burn the music files from your computer hard disc on a CDR or CDRW using your CD burner.

Helpful Hint:

- Make sure that the file names of the MP3 files end with **.mp3** and WMA files and with **.wma**.
- Total number of music files and albums: around 350 (with a typical file length of 20 characters)
- The length of file names affects the number of tracks for playback. With short file names, more files can be burned on a disc.

Windows Media Audio® is a registered trademark of Microsoft Corporation.

All trademarks used are owned by their respective owners.

ENVIRONMENTAL INFORMATION

- All redundant packing material has been omitted. We have done our utmost to make the packaging easily separable into two materials: cardboard (box) and polyethylene (bags, protective foam sheet).
- Your set consists of materials which can be recycled if disassembled by a specialized company. Please observe the local regulations regarding the disposal of packing materials, dead batteries and old equipment.

PLAYING A CD

With this set you can play
 – all pre-recorded audio CDs (CDDA)

Important: CDs encoded with **copyright protection technologies** by some record companies may be unplayable by this product.

- all finalized audio CDRs and CDRWs
- WMA/MP3-CDs (CD-ROMs with WMA/MP3 files)

1 Push the open ▲ slider to open the CD lid.

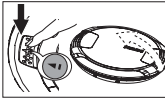

2 Insert a disc, printed side up, by pressing gently on the disc's center so that it fits onto the hub. Close the lid by pressing it down.



3 Press ►| to switch the player on and start playback.
 → Display shows **EXPANUM** and also **"READING CD"** if the reading time exceed 5 seconds, e.g. MP3/WMA-CD). Then, Audio CD: current track number appears. MP3/WMA: Current file name appears.



4 Press ►| briefly to interrupt playback.
 → The time where playback was interrupted blinks. Beep sounds at intervals.



5 To resume playback press ►| briefly again.

6 Press ■ to stop playback.
 → Audio CD: total playing time and total number of tracks appear. MP3/WMA: total number of albums/tracks appear.

PLAYING A CD

Helpful Hint:

- When playing a disc with CD Audio tracks and MP3 files, the CD Audio tracks will be played first..

- "0" is shown as your album number, if you have not organized your MP3/WMA files into any albums on your disc.

7 Press ■ again to switch off the CD player.

8 To remove the disc, hold it by its edge and press the hub gently while lifting the disc.

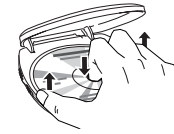

Auto-standby

When a CD has reached the end of playback and remains in the stop position for more than 25 seconds, the display will disappear. 65 seconds later, the set will automatically switch off to save mains.

VOLUME AND SOUND

Volume adjustment

- Adjust the volume by pressing **VOLUME +/-** (00 - 30, or **VOL +/-** on the remote control).

Helpful Hint:

Volume level resumes at:

- Default level 12: when starting playback from standby/power off mode.
- Previous level: when starting playback from the stop position.

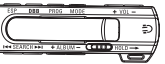

Bass adjustment

There are three DBB (Dynamic Bass Boost) options:

- Off: no bass enhancement
- **DBB 1** : moderate bass enhancement
- **DBB 2** : strong bass enhancement
- Press DBB once or more to select your option.
- **DBB 1 2** appears if DBB activated.

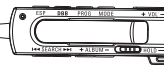

SELECTING A TRACK/ ALBUM AND SEARCHING

Selecting and searching on all discs

Selecting a track

- Briefly press ◀◀ or ▶▶ once or several times to skip to the beginning of the current, previous or subsequent track.
- In the pause/stop position, press ►| to start playback.
 → Playback continues with the selected track.

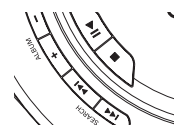

Searching for a passage during playback

- 1 Keep ◀◀ or ▶▶ pressed to find a particular passage in backward or forward direction.
 → Searching starts and playback continues at a low volume.
- 2 Release the button at the desired passage.
 → Normal playback continues.

Selecting on WMA/MP3-CDs

Selecting an album

- Briefly press **ALBUM +/-** once or several times to skip to the first track of the subsequent, current or previous album.
- In the pause/stop position, press ►| to start playback.
 → The first track of the selected album is played.

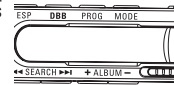

Selecting a track

- 1 Keep **ALBUM +/-** - pressed to skip quickly to the subsequent, current or previous MP3/ WMA tracks.
 → Skipping starts and speeds up after 5 seconds.
- 2 Release the button at the desired track.
 → Playback continues with the selected track.

Helpful Hint:

- When the program mode is active, use of the **ALBUM +/-** - keys are void.

PROGRAMMING TRACK NUMBERS

(remote control only)

You can select up to 50 tracks and store them in the memory in a desired sequence. You can store any track more than once.

- 1 Select a track with ◀◀ or ▶▶ (and also **ALBUM +/-** for a MP3/WMA-CD).
- 2 On the remote control, press **PROG** to store the track.
→ P with the number of stored tracks is displayed.
- 3 Select and store all desired tracks in this way.
- 4 If necessary, press ■ to stop normal playback. Press and hold ▶▶ briefly to start playback of the program.
→ **PROG** is shown and playback of the program starts.
- 5 To add additional tracks to your program, press ■ to stop playing the program and continue with step 1 and 2.
→ After 50 tracks are stored, **PROG FULL** is shown.



Reviewing the program

You can review the programme by pressing **PROG** for more than 3 seconds.
→ All stored tracks are displayed in sequence.

Clearing the program

- 1 If necessary press ■ to stop playback.
- 2 Press ■ to clear the program.
→ **Cleared** is displayed.

Helpful Hint:

- The program will also be cleared if you interrupt the power supply or open the CD lid or if the set switches off automatically.

DISPLAY INFORMATION

(WMA/MP3 tracks only)

- On the remote control, press and hold **MODE** 3 seconds to activate the display option mode. Within 2 seconds, press **MODE** briefly again, once or more to change and select your display option:
 - **FILENAME** : the track's file name
 - **ALBUM** : the album's folder name
 - **TITLE** : the track's title (if this ID3 tag information is available)
 - **ARTIST** : the artist's name (if this ID3 tag information is available)
 - **PLAYTIME**: the album number, elapsed playing time, and track number.

Helpful Hint:

- The ID3 tag is part of an WMA/MP3 file and contains various track information such as the track's title or the artist's name. Complete the ID3 tag information with your MP3 encoder software before burning the WMA/MP3-CD.
- The display can show a maximum of 31 characters.

SELECTING DIFFERENT PLAY OPTIONS – MODE

(remote control only)

You can select and change the various play modes before or during playback.

- 1 On the remote control, press **MODE** repeatedly to select any of the following:
 - **ALL** ↕ (Shuffle All): all tracks of the disc play in random order once.
 - **ALL** ↕ (Shuffle repeat all): all tracks of the disc play in random order repeatedly.
 - **1** (Repeat 1): the current track plays repeatedly.
 - **ALL** (Repeat All): all tracks of the disc/ program play repeatedly.
 - **Scan All** : each track in the disc/program plays 10 seconds in sequence.
- For MP3/WMA-CDs only:
- **↕** (Shuffle Album): all tracks of current album play in random order once.
 - **↕** (Shuffle Repeat Album): all tracks of current album play in random order repeatedly.
 - **↔** (Repeat Album): all tracks of current album play repeatedly.
→ The play mode is selected after its icon flashes 3 times.
- 2 Press ▶▶ to start playback if in the stop position.
 - 3 To return to normal playback, press **MODE** repeatedly until the play option icons e.g. ↕ and **ALL** disappear.

Helpful Hint:

- **↔**, **↕**, **ALL**, **Scan All** : only these play modes can be combined with programmed tracks.

ESP / POWERSAVING MODE

With a conventional portable CD-player you might have experienced that the music stopped e.g. when you were jogging. The **Electronic Skip Protection (ESP)** prevents loss of sound caused by light vibrations and shocks. Continuous playback is ensured. However ESP does not prevent playback interruptions during vigorous running. **It also does not protect the unit against any damage caused by dropping!**

The power save mode helps to extend battery service life for longer playback.

- To deactivate the shock protection and enter the power save mode, press **ESP**.
→ **ESP** disappears.
- Press **ESP** again.
→ **ESP** appears when shock protection is activated
- **Oops**: maximum **ESP** time exceeded. Playback skips but will resume optimum playback when the player is free from vibration.



200 SEC MAGIC ESP

Average playing times when ESP skip protection is activated:

Seconds track type

200	WMA-CD(64kbps)
100	MP3-CD(128kbps)
45	Audio CD

Helpful Hint:

- **ESP** is by default activated.

RESUME

(main set only, audio CD only)

RESUME - continuing from where you have stopped

You can store the last position played. When restarting, playback will continue from where you have stopped (RESUME). Use the **OFF-RESUME-HOLD** slider on the set for this function.

- 1 Switch the slider to **RESUME** during playback to activate RESUME.
 - 2 Press **■** whenever you want to stop playback.
 - 3 Press **▶II** whenever you want to resume playback (or on the remote control, press and hold **▶II** briefly).
 - Playback continues from where you have stopped.
- To deactivate RESUME, switch the slider to **OFF**.



HOLD

HOLD - locking all buttons

This player offers a double lock function to prevent buttons from being accidentally pressed and activated. You can choose to lock all buttons on either your set, remote control or even both! Simply adjust the respective **HOLD** slider to on or off position as desired. For example:

- Switch the **OFF•RESUME•HOLD** slider to **HOLD** to activate HOLD (or on the remote control, switch the **OFF•HOLD** slider to **HOLD**).

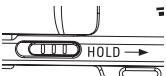

- All buttons are locked. **HOLD** is shown when you press any button on the set / remote control respectively. If the set is locked and switched off, **HOLD** will be shown only when you press **▶II**.

HOLD

TROUBLESHOOTING

WARNING: Under no circumstances should you try to repair the unit yourself as this will invalidate the warranty. If a fault occurs, first check the points listed, before taking the unit for repair. If you are unable to solve a problem by following these hints, consult your dealer or service center.

The CD player has no power, or playback does not start

- Check that your batteries are not dead or empty, that they are inserted correctly, that the contact pins are clean.
- Your adapter connection may be loose. Connect it securely.

The indication Insert CD is displayed

- Check that the CD is clean and correctly inserted (label-side upward).
- If your lens has steamed up, wait a few minutes for this to clear.
- Make sure the CD is not encoded with **Copyright protection technologies**, as some do not conform to the Compact Disc standard.

The indication Disc Error is displayed

- CD-RW (CD-R) was not recorded properly. Use FINALIZE on your CD-recorder.

The indication Non audio is displayed

- CD contains non-audio files. Insert a suitable disc or press **SEARCH** **◀◀** / **▶▶** once or more to skip to an audio track, instead of the data file.

The indication HOLD is on and/or there is no reaction to controls

- If **HOLD** is activated, then deactivate it.
- Electrostatic discharge. Disconnect power or remove batteries for a few seconds.

The CD skips tracks

- The CD is damaged or dirty. Replace or clean the CD.
- **SHUFFLE** or **PROG** is active. Switch off whichever is on.

No sound or bad sound quality.

- pause might be active. Press **▶II**.
- Loose, wrong or dirty connections. Check and clean connections.
- Volume might not be appropriately adjusted. Adjust the volume.
- Strong magnetic fields. Check player's position and connections. Also keep away from active mobile phones.

HOLD

- To deactivate HOLD, switch the slider to **OFF**.
 - All the buttons are unlocked.

Helpful Hint:

- If you deactivate HOLD by switching the slider on the set to RESUME, you will be activating the RESUME function.

ACOUSTIC FEEDBACK (BEEP)

Acoustic feedback is a beep signal that is heard when buttons on the set or remote control are pressed. Also, when the set or remote control is in pause mode or the battery power is low, it beeps at intervals.

- 1 Keep **DBB** pressed for more than 2 seconds to switch the beep either off or on.
 - **beep off** : Beep is switched off.
 - **beep on** : Beep is switched on.

Helpful Hint:

- Beep is on as the default setting.

Canada

English

This digital apparatus does not exceed the Class B limits for radio noise emissions from digital apparatus as set out in the Radio Interference Regulations of the Canadian Department of Communications.

Français

Cet appareil numérique n'émet pas de bruits radioélectriques dépassant les limites applicables aux appareils numériques de Classe B prescrites dans le Règlement sur le Brouillage Radioélectrique édicté par le Ministère des Communications du Canada.

PHILIPS LIMITED WARRANTY

One (1) Year Free Product Exchange

PHILIPS CONSUMER ELECTRONICS warrants this product against defect in material or workmanship, subject to any conditions set forth as follows:

PROOF OF PURCHASE:

You must have proof of the date of purchase to exchange the product. A sales receipt or other document showing the product, the date that you purchased the product, as well as the authorized retailer included, is considered such proof.

COVERAGE:

Warranty coverage begins the day you buy your product. For a period of one (1) year from the date of purchase, if the product is determined to be defective, Philips will exchange the defective product with a new or renewed product, at its option, at no charge. The replacement product is covered only for the warranty period of the original product. When the warranty on the original product expires, the warranty on all replaced products also expires. When it is necessary for you to ship the product to Philips for exchange, you will pay the shipping cost for shipment to Philips. Philips will pay the shipping costs when returning a product to you.

Note: The exchange model supplied will be the most comparable one in Philips current inventory. Shipping of your product to Philips implies intent to follow the specified requirements of the warranty and exchange program. Product received by Philips cannot be returned. Replacement product can only be sent if all warranty requirements are met. Failure to follow all requirements can result in delay of exchange process.

EXCLUDED FROM WARRANTY COVERAGE

Your warranty does not cover:

- Shipping charges to return defective product.
- Labor charges for installation or setup of the product, adjustment of customer controls on the product, and installation or repair of antenna systems outside of the product.
- Product repair and/or part replacement because of improper installation, connections to improper voltage supply, abuse, neglect, misuse, accident, unauthorized repair or other cause not within the control of Philips.
- Damage occurring to product during shipping when improperly packaged or cost associated with packaging.
- A product that requires modification or adaptation to enable it to operate in any country other than the country for which it was designed, manufactured, approved and/or authorized, or repair of products damaged by these modifications.
- A product used for commercial or institutional purposes (including but not limited to rental purposes).

- Products lost in shipment and no signature verification of receipt can be provided.
- Products sold AS IS or RENEWED.

WHERE WARRANTY EXCHANGE IS AVAILABLE:

Exchange is available in all countries where Philips officially distributes the product. In countries where Philips does not distribute the product, the local Philips organization will attempt to exchange the product, although there may be a delay if the appropriate product is not readily available, or special customs processes are implied.

FOR EXCHANGE IN THE U.S.A., PUERTO RICO, OR U.S. VIRGIN ISLANDS...

Contact Philips Customer Care Center at:
1-888-PHILIPS (1-888-744-5477)

FOR EXCHANGE IN CANADA...

1-800-661-6162 (French Speaking)
1-888-PHILIPS (1-888-744-5477) - (English or Spanish Speaking)

REPLACEMENT AS PROVIDED UNDER THIS WARRANTY IS THE EXCLUSIVE REMEDY OF THE CONSUMER. PHILIPS SHALL NOT BE LIABLE FOR ANY INCIDENTAL OR CONSEQUENTIAL DAMAGES FOR BREACH OF ANY EXPRESS OR IMPLIED WARRANTY ON THIS PRODUCT. EXCEPT TO THE EXTENT PROHIBITED BY APPLICABLE LAW, ANY IMPLIED WARRANTY OF MERCHANTABILITY OR FITNESS FOR A PARTICULAR PURPOSE ON THIS PRODUCT IS LIMITED IN DURATION TO THE DURATION OF THIS WARRANTY.

Some states do not allow the exclusions or limitation of incidental or consequential damages, or allow limitations on how long an implied warranty lasts, so the above limitations or exclusions may not apply to you. In addition, if you enter into a service contract agreement with the PHILIPS partnership within ninety (90) days of the date of sale, the limitation on how long an implied warranty lasts does not apply.

This warranty gives you specific legal rights. You may have other rights which vary from state/province to state/province.

Philips, P.O. Box 671539, Marietta, GA. 30006-0026

(Warranty: 4835 710 27325)