

Register your product and get support at

[www.philips.com/support](http://www.philips.com/support)

M888



Short user manual

**PHILIPS**



# Important safety instructions

## Warning

- The Electrical network is classified as hazardous. The only way to power down the charger is to unplug the power supply from the electrical outlet. Ensure that the electrical outlet is always easily accessible.
- Refer to safety information before using the product.
- This product complies with European R&TTE directive 1999/5/EC
- Use only the power supply listed in the user instructions.
- Use only the batteries listed in the user instructions.
- Do not allow the product to come into contact with liquids.
- Risk of explosion if battery is replaced by an incorrect type.
- Dispose of used batteries according to the instructions.
- When the handset rings or when the handsfree is activated, keep the handset away from your ear to avoid hearing damage.

## When using the phone as a baby monitor

- Children should be supervised to ensure that they do not play with the appliance.
- Make sure the baby unit and the cord are always out of reach of the baby (at least 1 metre/3 feet away).
- Keep the parent unit at least 1.5 metres/5 feet away from the baby unit to prevent acoustic feedback.
- Never place the baby unit inside the baby's bed or playpen.
- Never cover the parent unit and the baby unit with anything (e.g. a towel or blanket). Always make sure the cooling vents of the baby unit are free.
- This appliance is not intended for use by persons (including children) with reduced physical, sensory or mental capabilities, or lack of experience and knowledge, unless they have been given supervision or instruction concerning use of the appliance by a person responsible for their safety.

- If you place the parent unit next to a transmitter or other DECT appliance (e.g. a DECT telephone or wireless router for the internet), the connection with the baby unit may be lost. Move the baby monitor further away from the other wireless appliances until the connection is restored.
- This baby monitor is intended as an aid. It is not a substitute for responsible and proper adult supervision and should not be used as such.

# 1 Overview

## In call

/ Enter the option menu.

**OK**

Change the sound profile.

Adjust the volume.

Recall (network dependent).

End calls.

Turn the speaker on/off.

Mute/unmute the microphone.

# a/A Enter a pause (press and hold).

## In menu

/ Confirm / Select / Enter the option menu.

**OK**

Cancel

Up / down

Exit menu.

## Standby

/ Access the main menu.

**OK**

Access the redial list.

Phonebook

Call log

Make and receive calls.

\*INT Make intercom call (press and hold).  
Multi-handset version only.

Lock/unlock the keypad (press and hold).

Make and receive calls through the speaker.

## In text input

Delete a character.  
Delete all characters (press and hold).

Enter a space.

# a/A Switch upper/lower case (press and hold).

Left / right

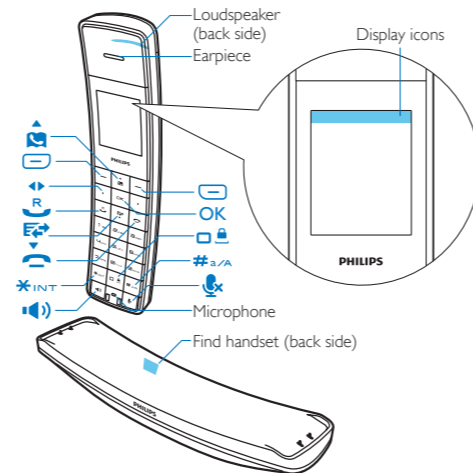

## Main menu icons

- Alarm
- Phonebook
- Services
- Sounds
- Phone setup
- Baby monitor
- Display
- Answer machine

## Display icons

The number of bars indicates the connection status between the handset and base station. The more bars are shown, the better the signal strength is.

It remains steadily on beside the unread missed call record when browsing the call log.

It flashes when there is a new missed call. It remains steadily on when browsing missed calls in call log.

The alarm is activated.

The silent mode is set, but is outside of active period.

The speaker is on.

The ringer is off.  
The silent mode is set and within active period (the phone does not ring).

Answering machine: it flashes when there is a new message. It remains steadily on when the telephone answering machine is turned on.

Voice messages indicator: flashes for new messages, is steady for reviewed messages.  
\*This is network dependent

ECO The ECO mode is activated.

ECO+ The ECO+ mode is activated.

## 2 Connect

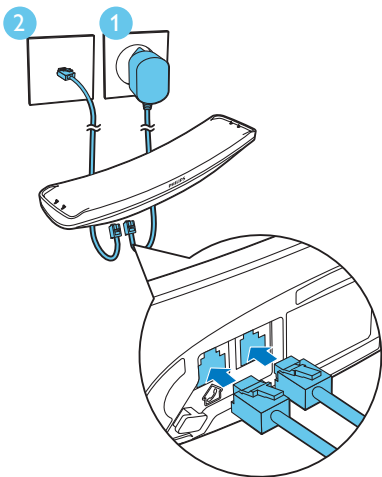

## 3 Get started

### Configure your phone

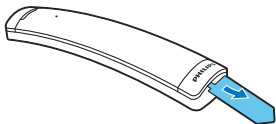

- 1 The batteries are pre-installed in the handset. Pull the battery tape off from the battery door before charging.
- 2 When using your phone for the first time, you see a welcome message (country dependent).
- 3 Set the country and language if prompted.
- 4 Set the date and time.
  - If the time is in 12-hour format, press  to select **[am]** or **[pm]** (country dependent).

### Charge your phone

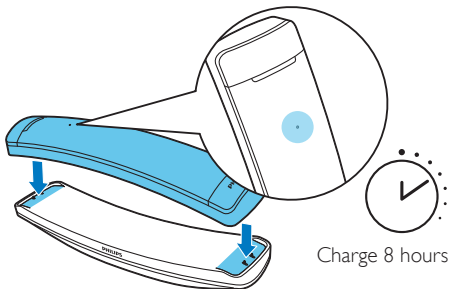

Charge your handset by docking it in either direction. The LED at the back of the handset flashes once.

 > 84%

 36% - 52%

 68% - 84%

 18% - 36%

 52% - 68%

 < 18%

Flashing: low battery

# 4 Enjoy

## Phonebook

### Add record

- 1 Press > [Option] > [Add new].
- 2 Follow on-screen instructions.

### Call from the phonebook

- 1 Press .
- 2 Select a record and press .

### Direct access memory

You have 9 direct access memories (Keys 1 to 9). To dial the saved phone number automatically, press and hold on the keys in standby mode.

Depending on your country, keys 1 and 2 are preset to the voice mail number and information service number of your service provider respectively (network dependent).

## Call log

### Call from the call log

- 1 Press > [Incoming calls].
- 2 Select a record and press .

### View record

- 1 Press > [Incoming calls].
- 2 Select a record and select [Option] > [View].

### Save record

- 1 Press > [Incoming calls].
- 2 Select a record and select [Option] > [Save number].
- 3 Follow on-screen instructions.

### Delete record

- 1 Press > [Incoming calls].
- 2 Select a record and select [Option] > [Delete].
- 3 Follow on-screen instructions.

## Redial list

### Call from the redial list

- 1 Press [Redial].
- 2 Select a record and press .

### Save record

- 1 Press [Redial].
- 2 Select a record and select [Option] > [Save number].
- 3 Follow on-screen instructions.

### Delete record

- 1 Press [Redial].
- 2 Select a record and select [Option] > [Delete].
- 3 Follow on-screen instructions.

## Telephone answering machine

### Record an announcement

- 1 Press [Menu].
- 2 Press / to select > [Announcement].
- 3 Follow on-screen instructions.

### Listen to the incoming messages

Select [Menu] > > [Play], then press [OK] to confirm.

### Delete an incoming message

- 1 When you listen to the message, press [Option] to enter the options menu.
- 2 Select [Delete], then press [OK] to confirm.

## Register additional handsets

You can register additional handsets to the base station.

- 1 Select [Menu].
- 2 Press / to select > [Register].
- 3 Press and hold on the base station for 5 seconds.
- 4 Enter the system PIN/passcode (0000).
- 5 Press [OK] to confirm the PIN/passcode.  
↳ Registration is complete in less than 2 minutes.

# 5

## Learn more

### Silent mode

Sets time during which the phone will not ring

 > [Silent mode]

### MySound

Customizes the sound of voices to your liking

 > [MySound]

### Eco mode

Reduces power consumption / transmission power; reduces radiation and range by approximately 60%

 > [Eco mode]

### Eco+ mode

Eliminates radiation in standby mode (causes 2 seconds ring delay, 50% shorter standby time)

 > [ECO+ mode]

### Call barring

Prevents unwanted outgoing calls to selected numbers

 > [Call barring]



# Technical data

## Battery

- Philips: 2 x AAA NiMH 1.2 V Rechargeable 550 mAh batteries

Use only the supplied batteries.

## Adapter

- MEIC: MN-A075-U056  
Input: 100-240V~ 50/60 Hz 200 mA;  
Output: (i)6.5V 300 mA, (ii)7.5V 200 mA

Phonebook with 250 entries

Call log with 50 entries

Talk time: 18 hours

Standby time: 250 hours



## Note

- You can install a DSL (digital subscriber line) filter to prevent noise and caller ID problems caused by the DSL interference.
- You can find the Declaration of Conformity on [www.p4c.philips.com](http://www.p4c.philips.com).







# ? Frequently asked questions





## No signal bar is displayed on the screen.

- The handset is out of range. Move it closer to the base station.
- If the handset displays **[Register your Handset]**, register your handset. (See the section on "Register additional handsets").

## If I fail to pair (register) the additional handsets to the base station, what do I do?

Your base memory is full. Press . Then press  /  to select  > **[Unregister]** to unregister the unused handsets and try again.

## I have chosen a wrong language which I cannot read, what do I do?

- 1 Press  to go back to the standby screen.
- 2 Press  to access the main menu screen.
- 3 Press  /  to select , then you see one of the following texts appear on the screen:

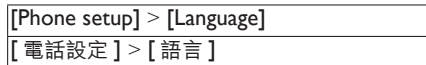

- 4 Select it to access the language options.
- 5 Select your own language.

## My handset is in searching status, what do I do?

- Make sure that the base station has power supply.
- Register the handset to the base station.
- Move the handset closer to the base station.

## I cannot change the settings of my voice mail, what do I do?

The voice mail service is managed by your service provider but not the phone itself. Contact your service provider to change the settings.

## No display

- Make sure the batteries are charged.
- Make sure there are power and phone connections.

## The handset on the charger does not charge.

- Make sure the batteries are inserted correctly.
- Make sure the handset is placed properly on the charger. The LED at the back of the handset flashes once.
- Make sure the docking tone setting is turned on. When the handset is placed correctly on the charger, you can hear a docking tone.
- The charging contacts are dirty. Disconnect the power supply first and clean the contacts with a damp cloth.
- Batteries are defective. Purchase new ones with the same specifications.

## Bad audio (crackles, echo, etc.)

- The handset is nearly out of range. Move it closer to the base station.
- The phone receives interference from the nearby electrical appliances. Move the base station away from them.
- The phone is at a location with thick walls. Move the base away from them.

## The handset does not ring.

Make sure the handset ringtone is turned on.

## The caller ID does not display.

- The service is not activated. Check with your service provider.
- The caller's information is withheld or unavailable.

i



[www.philips.com/support](http://www.philips.com/support)

For information, refer to the extended user documentation online.



# CE 0168

This symbol on a product means that the product is covered by European Directive 2012/19/EU.

2015 © Gibson Innovations Limited.

All rights reserved.

This product has been manufactured by, and is sold under the responsibility of Gibson Innovations Ltd., and Gibson Innovations Ltd. is the warrantor in relation to this product.

Philips and the Philips Shield Emblem are registered trademarks of Koninklijke Philips N.V. and are used under license from Koninklijke Philips N.V.



UMS\_M888  
90\_EN\_V3.0  
WK15333