

Register your product and get support at  
[www.philips.com/welcome](http://www.philips.com/welcome)

CEM220



---

EN User manual

---

RU Руководство пользователя

**PHILIPS**

# Contents

<b>1 Important</b>	4
Safety	4
Notice	4
<b>2 Your car audio system</b>	6
Introduction	6
What's in the box	6
Overview of the main unit	7
Overview of the remote control	8
<b>3 Get started</b>	10
Install the car audio	10
Install remote control battery	14
Turn on	14
Set clock	14
<b>4 Listen to radio</b>	15
Tune to a radio station	15
Store radio stations in memory	15
Tune to a preset station	15
Play with RDS	15
<b>5 Play audio files</b>	18
Play a disc	18
Play from USB/SD/SDHC/MMC device	18
Control play	19
Search for an MP3/WMA track	19
View play information	19
Intro play	20
Shuffle play	20
Repeat play	20
Connect external sound source	20
<b>6 Adjust sound</b>	21
Adjust volume	21
Mute	21
Turn Dynamic Bass Boost (DBB) on/off	21
Select preset equalizer	21
Other sound settings	21
<b>7 Adjust system settings</b>	22
Select blackout setting	22
Turn demo mode on/off	22
Change button backlight color	22
Select start volume	22
Turn beep sound on/off	23
Turn display scroll on/off	23
Select shock-protect setting	23
Reset	23
<b>8 Additional information</b>	24
Detach the front panel	24
Replace fuse	24
Remove the unit	24
<b>9 Product information</b>	25
<b>10 Troubleshooting</b>	26
<b>11 Glossary</b>	27

# 1 Important

## Safety

- Read and understand all instructions before you use your apparatus. If damage is caused by failure to follow instructions, the warranty does not apply.
- This apparatus is designed for negative ground (earth) 12 V DC operation only.
- To ensure safe driving, adjust the volume to a safe and comfortable level.
- Improper fuses can cause damage or fire. When you need to change the fuse, consult a professional.
- Use only the supplied mounting hardware for a safe and secure installation.
- To avoid short circuit, do not expose the apparatus, remote control or remote control batteries to rain or water.
- Never insert objects into the ventilation slots or other openings on the apparatus.
- Clean the apparatus and frame with a soft, damp cloth. Never use substances such as alcohol, chemicals or household cleaners on the apparatus.
- Never place any objects other than discs into the apparatus.
- Never use solvents such as benzene, thinner, cleaners available commercially, or anti-static sprays intended for discs.
- Visible and invisible laser radiation when open. Avoid exposure to beam.
- Risk of damage to the apparatus screen! Never touch, push, rub or strike the screen with any object.

### Caution

- Use of controls or adjustments or performance of procedures other than herein may result in hazardous radiation exposure or other unsafe operation.

## Notice



The making of unauthorized copies of copy-protected material, including computer programs, files, broadcasts and sound recordings, may be an infringement of copyrights and constitute a criminal offence. This equipment should not be used for such purposes.

**This apparatus includes these labels:**



Class II equipment symbol



This symbol indicates that the apparatus has a double insulation system.

## Recycling



Your product is designed and manufactured with high quality materials and components, which can be recycled and reused.

When you see the crossed-out wheel bin symbol attached to a product, it means the product is covered by the European Directive 2002/96/EC:



Never dispose of your product with other household waste. Please inform yourself about the local rules on the separate collection of electrical and electronic products. The correct disposal of your old product helps prevent potentially negative consequences on the environment and human health.

Your product contains batteries covered by the European Directive 2006/66/EC, which cannot be disposed of with normal household waste.

Please inform yourself about the local rules on separate collection of batteries. The correct disposal of batteries helps prevent potentially negative consequences on the environment and human health.



This product complies with the radio interference requirements of the European Community.

This product complies with the requirements of the following directives and guidelines: 2004/108/EC + 2006/95/EC.

#### **Environmental information**

All unnecessary packaging has been omitted. We have tried to make the packaging easy to separate into three materials: cardboard (box), polystyrene foam (buffer) and polyethylene (bags, protective foam sheet.)

Your system consists of materials which can be recycled and reused if disassembled by a specialized company. Please observe the local regulations regarding the disposal of packaging materials, exhausted batteries and old equipment.

Any changes or modifications made to this device that are not expressly approved by Philips Consumer Lifestyle may void the user's authority to operate the equipment.

2009 © Koninklijke Philips Electronics N.V. All rights reserved.

Specifications are subject to change without notice. Trademarks are the property of Koninklijke Philips Electronics N.V. or their respective owners. Philips reserves the right to change products at any time without being obliged to adjust earlier supplies accordingly.

## 2 Your car audio system

Congratulations on your purchase, and welcome to Philips! To fully benefit from the support that Philips offers, register your product at [www.philips.com/welcome](http://www.philips.com/welcome).

---

### Introduction

With the in-car audio system, you can enjoy your drive while you listen to:

- FM or AM (MW) radio
- Audio from CD or MP3 disc
- Audio from a USB drive
- Audio from a SD/MMC card
- Audio from external devices

---

### What's in the box

Check and identify the contents of your package:



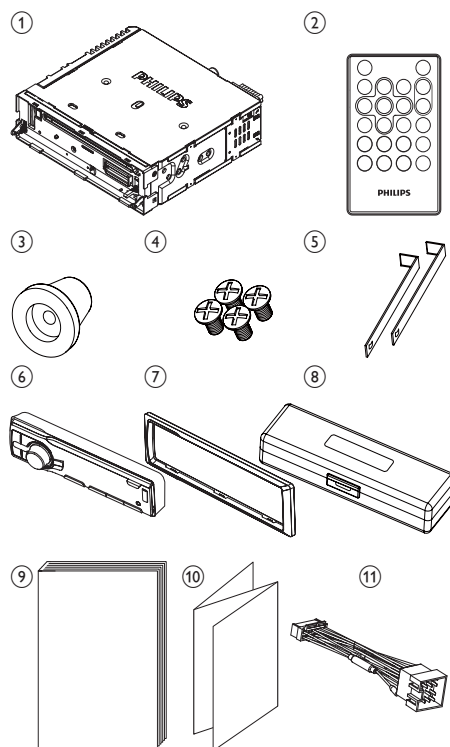

- ① In-car audio system
- ② Remote control
- ③ Rubber cushion
- ④ Screw (4 pieces)
- ⑤ Disassembly tool ( 2 pieces)
- ⑥ Front panel
- ⑦ Trim plate
- ⑧ Carrying case for front panel
- ⑨ User manual
- ⑩ Quick start guide
- ⑪ Standard connector

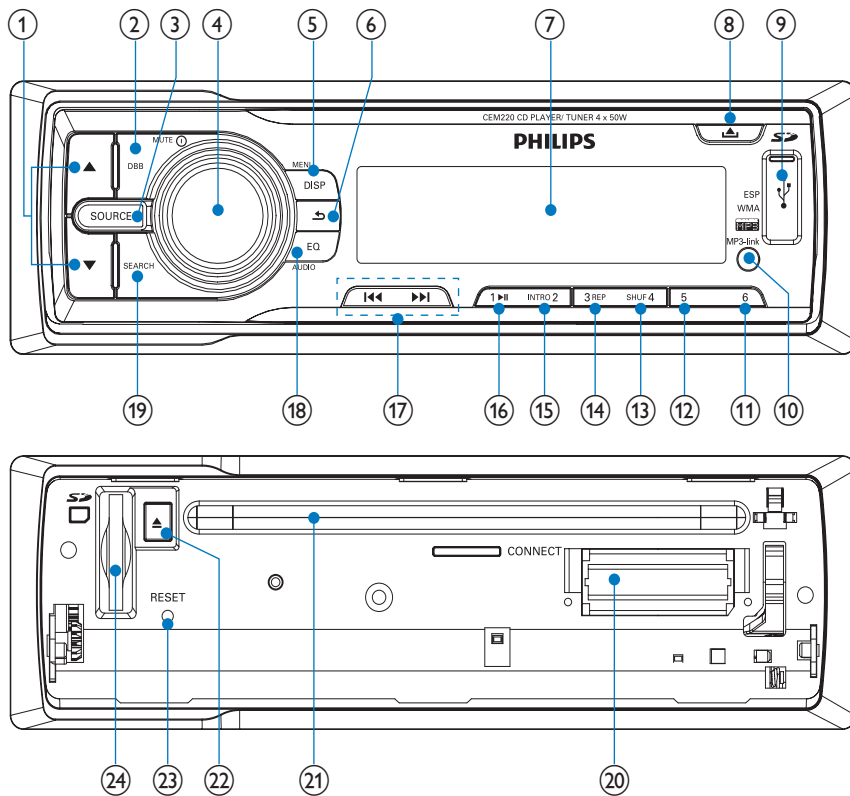

## Overview of the main unit



- ① ▲▼
  - Select tuner band.
  - Select MP3/WMA folder.
  - Scroll up or down menu.
  - Select RDS program type.
- ② DBB
  - Turn on or off Dynamic Bass Boost (DBB) sound.
- ③ SOURCE
  - Select audio source.
- ④ ○/MUTE
  - Turn the unit on or off.
  - Adjust volume.
  - Confirm selection.
  - Enter characters for search.
  - Mute or restore volume.
- ⑤ MENU / DISP
  - Display radio frequency, clock and radio program type (if available).
  - Display track, elapsed time, artist, album, title, folder, file and clock.
  - Access system menu.
  - Access RDS (Radio Data System) menu.

- ⑥ 
  - Return to previous menu.
  - Stop search.
  - Disable screen blackout.
- ⑦ **Display panel**
- ⑧ 
  - Unlock the panel
- ⑨ **USB socket**
- ⑩ **External device socket**
- ⑪ **6**
  - Select preset station no. 6
- ⑫ **5**
  - Select preset station no. 5
- ⑬ **SHUF, 4**
  - Activate or deactivate shuffle mode.
  - Select preset station no. 4
- ⑭ **3, REP**
  - Set repeat play mode.
  - Select preset station no. 3
- ⑮ **INTRO, 2**
  - Turn intro play on or off.
  - Select preset station no. 2
- ⑯ **1, **
  - Start play
  - Pause or resume play.
  - Select preset station no. 1
- ⑰ ****
  - Tune to a radio station
  - Skip/search for a track.
- ⑱ **EQ/Audio**
  - Select equalizer (EQ) setting.
  - Access audio setting menu.
- ⑲ **SEARCH**
  - Store radio stations automatically.
  - Search a track or folder.
- ⑳ **Panel power connection**
- ㉑ **Disc slot**
- ㉒ 
  - Take disc out.

- ㉓ **RESET**
  - Restore default settings
- ㉔ **SD/MMC card slot**

## Overview of the remote control

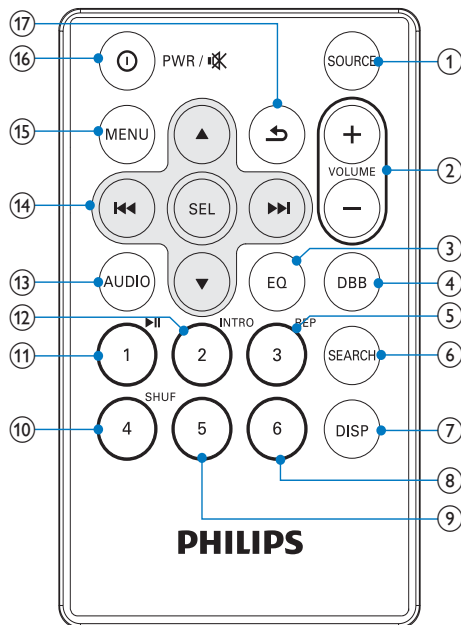

- ① **SOURCE**
  - Select audio source.
- ② **VOLUME +/-**
  - Adjust volume.
- ③ **EQ**
  - Select EQ setting.
- ④ **DBB**
  - Turn on or off Dynamic Bass Boost (DBB) sound.
- ⑤ **3, REP**
  - Select repeat play mode.
  - Select preset station no. 3.

- ⑥ **SEARCH**
  - Store radio stations automatically.
  - Search a track or folder.
- ⑦ **DISP**
  - Display radio frequency and clock.
  - Display track, elapsed time, artist, album, title, folder, file and clock.
- ⑧ **6**
  - Select preset station no. 6.
- ⑨ **5**
  - Select preset station no. 5.
- ⑩ **SHUF, 4**
  - Activate or deactivate shuffle mode.
  - Select preset station no. 4.
- ⑪ **1, ►||**
  - Start play.
  - Pause or resume play.
  - Select preset station no. 1.
- ⑫ **INTRO, 2**
  - Turn intro play on or off.
  - Select preset station no. 2.
- ⑬ **AUDIO**
  - Access audio setting menu.
- ⑭ **Navigation buttons**
  - **◀◀▶▶**  
Tune for radio station  
Skip/search for MP3/WMA track.
  - **▲/▼**  
Select tuner band.  
Select MP3/WMA folder.  
Select RDS program type.
  - **SEL**  
Confirm selection.
- ⑮ **MENU**
  - Access system menu.
  - Access RDS (Radio Data System) menu.
- ⑯ **ⓅPWR, 🔊**
  - Turn the unit on or off.
  - Mute or restore volume.
- ⑰ **↶**
  - Return to previous menu.
  - Disable screen blackout.



## 3 Get started

### ! Caution

- Use the controls only as stated in this user manual.

Always follow the instructions in this chapter in sequence.

If you contact Philips, you will be asked for the model and serial number of your apparatus. The model number and serial number are on the bottom of your apparatus. Write the numbers here:

Model No. \_\_\_\_\_

Serial No. \_\_\_\_\_

### Install the car audio

These instructions are for a typical installation. However, if your car has different requirements, make the corresponding adjustment. If you have any questions regarding installation kits, consult your Philips car audio dealer.

### ! Caution

- This unit is designed for negative ground (earth) 12 V DC operation only.
- Always install this unit in the car dashboard. Other locations can be dangerous as the rear of the unit heats up during use.
- To avoid short-circuit: before you connect, ensure that the ignition is off.
- Ensure that you connect the yellow and red power supply leads after all other leads are connected.
- Ensure that all loose leads are insulated with electrical tape.
- Ensure that the leads do not get caught under screws or in parts that will move (e.g. seat rail).
- Ensure that all ground (earth) leads are run to a common ground (earth) point.
- Use only the supplied mounting hardware for a safe and secure installation.
- Improper fuses can cause damage or fire. When you need to change the fuse, consult a professional.

### Note on the power supply lead (yellow)

- When you connect other devices to this apparatus, ensure that the rating of the car circuit is higher than the total fuse value of all the connected devices.

### Notes on speaker connection

- Never connect speaker wires to the metal body or chassis of the car.
- Never connect speaker wires with stripes to one another.

### Overview of parts

These are the supplied parts needed to connect and install this unit.

- ① In-car audio system
- ② Sleeve
- ③ Front panel
- ④ Trim plate
- ⑤ Rubber cushion
- ⑥ Disassembly tools
- ⑦ Screws (4 pieces)
- ⑧ ISO connector

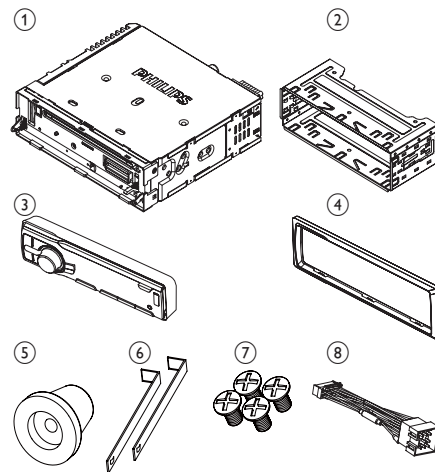

## Connection: for cars with ISO connectors

### ! Caution

- Ensure that all loose leads are insulated with electrical tape.

- 1 Pull out the ISO connectors from car dashboard and connect them to the bigger end of the supplied standard connector.

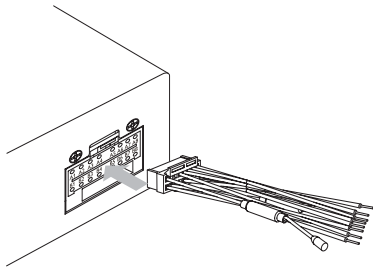

- 2 Connect the other end of the supplied standard connector to the unit.

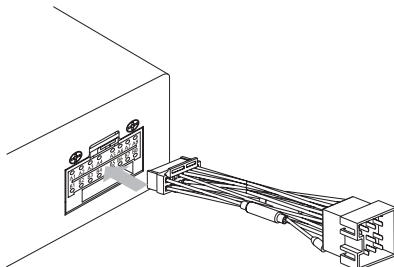

- 3 Connect the antenna and amplifier as illustrated, if applicable.

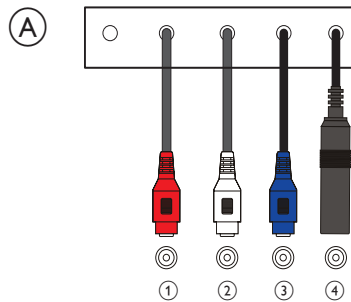

	Connector	Connect to
1	REAR LINE OUT R	Rear right speaker
2	REAR LINE OUT L	Rear left speaker
3	SUB OUT	Subwoofer
4	ANTENNA	Antenna

## Connection: for cars without ISO connectors

### ! Caution

- Be sure to connect the black ground (earth) lead first.

- 1 Connect the antenna and amplifier as illustrated, if applicable.

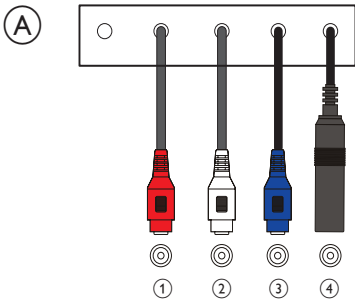

	Connector	Connect to
1	REAR LINE OUT R	Rear right speaker
2	REAR LINE OUT L	Rear left speaker
3	SUB OUT	Subwoofer
4	ANTENNA	Antenna

1	Green/black strip	Left speaker (Rear)
2	White/black strip	Left speaker (Front)
3	Gray/black strip	Right speaker (Front)
4	Purple/black strip	Right speaker (Rear)

e	RED	Ignition key +12V DC when ON/ACC
f	BLUE	Motor/electric antenna relay control lead/ Amplifier relay control lead
g	BLACK	Ground
h	PINK	Illumination switch
i	YELLOW	To the +12V car battery which is energized at all times

- Cut off the bigger end of the supplied standard connector.
- Check the car's wiring carefully and connect them to the supplied standard connector.

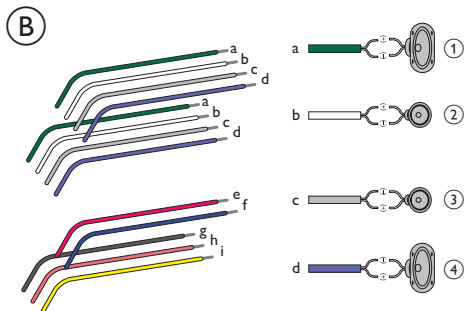

- Connect the supplied standard connector to the unit.

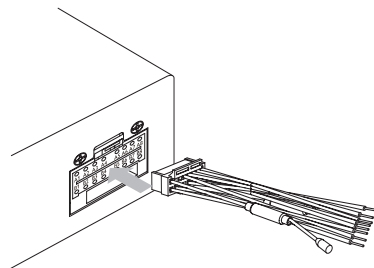

**Mount in the dashboard**

- 1 If the car does not have an on-board drive or navigation computer, disconnect the negative terminal of the car battery.
  - If you disconnect the car battery in a car that has an on-board drive or navigation computer, the computer may lose its memory.
  - If the car battery is not disconnected, to avoid short-circuit, ensure that bare wires do not touch each other.
- 2 Remove the two screws on the top of the unit.

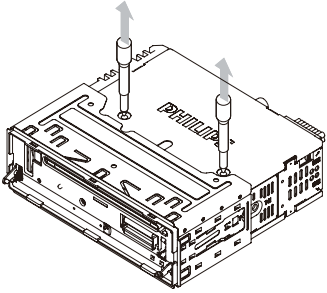

- 3 Remove the mounting sleeve with the supplied disassembly tools.

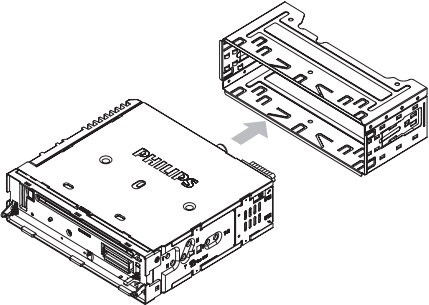

- 4 Ensure that car dashboard opening is within these measurements:

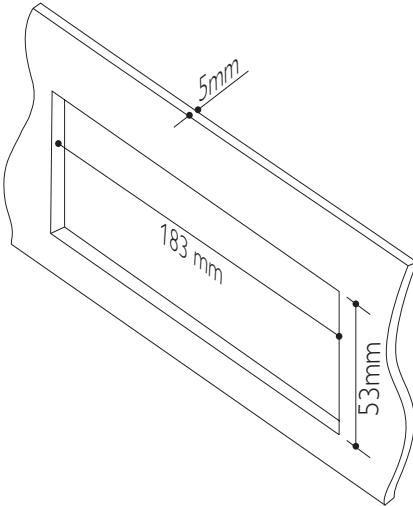

- 5 Install the sleeve into the dashboard and bend the tabs outward to fix the sleeve.

**Note**

- Skip this step if the unit is not fixed by sleeve but by supplied screws.

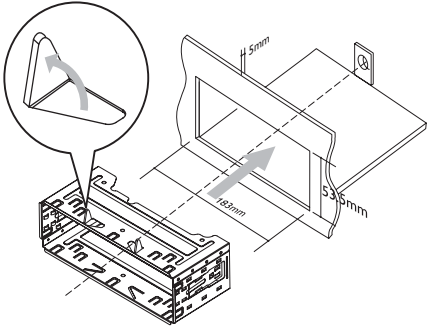

- 6 Place the supplied rubber cushion over the end of the mounting bolt.

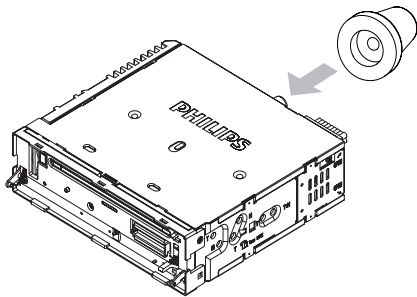

- 7 Slide the unit into the dashboard until you hear a click sound.
- 8 Reconnect the negative terminal of the car battery.

### Attach the front panel

- 1 Attach the trim plate.

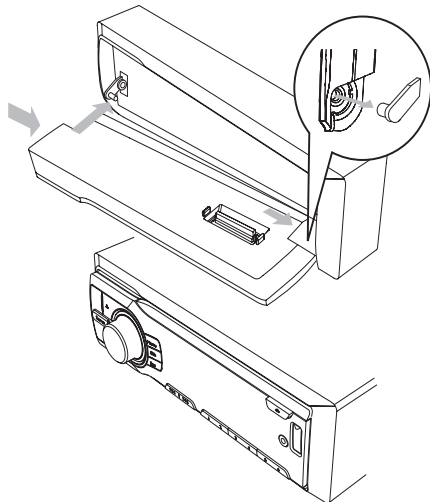

- 2 Insert the right side of the panel in the chassis until it is correctly engaged.
- 3 Press the left side of the panel and point the left hole at the left pillar.
- 4 Release the panel to engage the left side.

## Install remote control battery

### ! Caution

- Risk of explosion! Keep batteries away from heat, sunshine or fire. Never discard batteries in fire.
- Risk of decreased battery life! Never mix different brands or types of batteries.
- Risk of product damage! When the remote control is not used for long periods, remove the batteries.
- Perchlorate Material - special handling may apply. See [www.dtsc.ca.gov/hazardouswaste/perchlorate](http://www.dtsc.ca.gov/hazardouswaste/perchlorate).

### For first-time use:

- 1 Remove the protective tab to activate the remote control battery.
- 2 Open the battery compartment.
- 3 Insert 1 CR2025 batteries with correct polarity (+/-) as indicated.
- 4 Close the battery compartment.

## Turn on

- 1 Press  $\odot$  to turn on the unit.
  - To turn off the unit, press  $\odot$  for 3 seconds.

## Set clock

- 1 Press **MENU/DISP** for 3 seconds.
- 2 Press  $\blacktriangle$  or  $\blacktriangledown$  repeatedly to until the currently time is displayed.
- 3 Turn  $\odot$  clockwise to set hour.
- 4 Press  $\odot$  to confirm.
- 5 Turn  $\odot$  anti-clockwise to set minute.
- 6 Press  $\odot$  to confirm.

## View clock

- 1 Press **MENU/DISP** repeatedly until the clock is displayed.

## 4 Listen to radio

### Tune to a radio station

- 1 Press **SOURCE** repeatedly to select Tuner.
- 2 Press **▲** or **▼** to select band: **[FM1]**, **[FM2]**, **[FM3]**, **[AM1]**, or **[AM2]**.
- 3 Press **◀◀** or **▶▶** to tune to a radio station manually.
  - ↳ The radio station is broadcast.
  - ↳ To search for a radio station automatically, press **◀◀** or **▶▶** for 3 seconds.

### Select tuner sensitivity

You can adjust the tuner sensitivity if you want to receive more radio stations or only stations with strong signal.

- 1 Press **MENU/DISP** for over 2 seconds.
- 2 Press **▲** or **▼** repeatedly until **[LOCAL]** or **[DX]** is displayed.
- 3 Rotate **⊖** to select a setting:
  - **[LOCAL]** (local): Only stations with strong signal can be broadcast.
  - **[DX]** (distance): Stations with strong and weak signals can be broadcast.
- 4 Press **⊖** to confirm the selection.

### Select stereo/mono broadcasting

For stations with weak signals: to improve the reception, change to monoaural sound.

- 1 Press **MENU/DISP** for 3 seconds.
- 2 Press **▲** or **▼** repeatedly until **[STEREO]** or **[MONO]** is displayed.
- 3 Turn **⊖** to select a setting:
  - **[STEREO]**: stereo broadcast.
  - **[MONO]**: mono broadcast.
- 4 Press **⊖** to confirm the selection.

### Store radio stations in memory

You can store up to 6 stations in each band.

#### Store stations automatically

- 1 Press **SEARCH** for 3 seconds.
  - ↳ The six strongest stations of the selected band are saved in preset channels 1-6 automatically.

#### Store stations manually

- 1 Tune to a station that you want to store. (see 'Tune to a radio station' on page 16)
- 2 Press one of the numbered buttons **1** to **6** for 3 seconds.
  - ↳ The station is saved in the selected channel.

### Tune to a preset station

- 1 Press **▲** or **▼** to select band.
- 2 Press the number button **1** to **6** to select the preset station.

### Play with RDS

The RDS (Radio Data System) function operates only in areas with FM stations broadcasting RDS signals. If you tune to an RDS station, an RDS icon and information about the presenter, station or program is displayed.

#### Turn on RDS



#### Note

- By default, the RDS function is off.

- 1 Press **MENU/DISP** for 3 seconds.

- 2 Turn  $\odot$  to select [RDS ON]:
  - ↳ [RDS] is displayed.
- To turn off the RDS function, repeat steps above and choose [RDS OFF].

### Select program type

Before tuning to RDS stations, you can select program type and let the unit search only for programs of the selected category.

- 1 Press  $\blacktriangledown$ /SEARCH until [AUTO--SCN] or [PTY] is displayed.
- 2 Press  $\blacktriangle$  or  $\blacktriangledown$  to select [PTY], then press  $\odot$ /MUTE to confirm.
- 3 Turn  $\blacktriangle$  or  $\blacktriangledown$  to select a program type, then press  $\odot$ /MUTE to start searching.
  - ↳ "PTY SEEK" is displayed.

Item	Program type	Description
1	NEWS	News services
2	AFFAIRS	Politics and current affairs
3	INFO	Special information programs
4	SPORT	Sports
5	EDUCATE	Education and advanced training
6	DRAMA	Radio plays and literature
7	CULTURE	Culture, religion and society
8	SCIENCE	Science
9	VARIED	Entertainment programs
10	POP M	Pop music
11	ROCK M	Rock music
12	EASY M	Light music
13	LIGHT M	Light classical music
14	CLASSICS	Classical music
15	OTHER M	Special music programs

16	WEATHER	Weather
17	FINANCE	Finance
18	CHILDREN	Children's programs
19	SOCIAL	Social Affairs
20	RELIGION	Religion
21	PHONE IN	Phone In
22	TRAVEL	Travel
23	LEISURE	Leisure
24	JAZZ	Jazz Music
25	COUNTRY	Country Music
26	NATION M	National Music
27	OLDIES	Oldies Music
28	FOLK M	Folk Music
29	DOCUMENT	Documentary
30	TEST	Alarm Test
31	ALARM	Alarm

### Store RDS stations

You can store up to six (6) RDS stations in each FM band in preset channels.

#### Note

- If you have stored radio stations in the preset channels (see 'Store radio stations in memory' on page 16), below operation will replace the pre-stored stations.

- 1 Turn on RDS (see 'Turn on RDS' on page 16).
- 2 Select band:[FM1], [FM2] or [FM3] .
- 3 PressSEARCH/ $\blacktriangledown$  for 3 seconds.
  - ↳ [AUTO - SCN] or [PTY] is displayed.
- 4 Press  $\blacktriangle$  or  $\blacktriangledown$  to select [AUTO - SCN].
- 5 Press  $\odot$  to start searching.
  - ↳ Six RDS stations with strongest signal are stored in channel 1 to 6.

### Select alternate frequencies

If the radio signal from the current station is poor, you can turn on the AF (Alternate Frequency) function to let the unit search for another station with a stronger signal but with the same program identification as the current station automatically.

- 1 Press **MENU/DISP** for 3 seconds.
- 2 Press **▲** or **▼** repeatedly until **[AF]** is displayed.
- 3 Turn **⊕** to select a setting:
  - **[AF ON]**: Turn on the AF mode.
  - **[AF OFF]**: Turn off the AF mode.

### Set region for AF tuning

You can define AF tuning region:

<b>[REG ON]</b>	Only stations in the current region can be tuned to automatically.
<b>[REG OFF]</b>	All stations can be tuned to automatically.

- 1 Press **MENU/DISP** for 3 seconds.
- 2 Press **▲** or **▼** repeatedly until **[REG]** (Regional Radio) is displayed.
- 3 Turn **⊕** to select a setting.

### Receive traffic announcement

If you do not want to miss traffic announcement during enjoying music, you can turn on the TA (Traffic Announcement) function.

- 1 Press **MENU/DISP** for 3 seconds.
- 2 Press **▲** or **▼** repeatedly until **[TA]** is displayed.

- 3 Turn **⊕** to select a setting:
  - **[TA ON]**: When there is traffic announcement, the unit switches to the tuner mode (regardless of the current mode) and begins to broadcast the announcement on traffic conditions. When the traffic announcement is over, it returns to the previous mode.
  - **[TA OFF]**: Traffic announcement does not cut in.

### Set TA volume

When TA (traffic announcement) signal is interrupted, the volume can keep at a preset level. Follow steps below to set TA volume:

- 1 Press **MENU/DISP** for 3 seconds.
- 2 Press **▲** or **▼** repeatedly until **[TA VOL]** is displayed.
- 3 Turn **⊕** to select a volume level: 12(minimum) to 45(maximum).



## 5 Play audio files

### Note

- Ensure that the disc or device contains playable files.

### Play a disc

### Note





- You cannot play CDs encoded with copyright protection technologies.

You can play commercially available audio CDs and these discs:

- CD-Recordables (CD-R)
- CD-Re-writables (CD-RW)
- MP3 CDs
- WMA CDs



### Note

- Ensure that the disc contains playable content.

- 1 Press  on the front panel to release the panel.
- 2 Insert a CD with the printed side facing up.
- 3 Close the panel.
- 4 Press 1,  to start play.
  - To pause CD play, press 1 .
  - To resume CD play, press 1 .

### Remove the CD

To take out the CD,

- 1 Press .
- 2 Press  beside the disc slot.

### Tip

- If the disc is blocked in the disc compartment, press and hold  until the disc comes out.

### Play from USB/SD/SDHC/ MMC device

### Note

- Ensure that the USB or SD/SDHC/MMC device contains playable music.

### Insert the USB device

- 1 Open the cover marked  on the front panel.

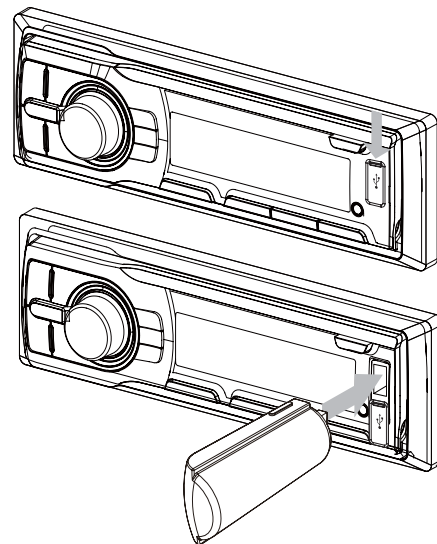

- 2 Insert the USB device into the USB socket.
  - ↳ The unit starts playing from the USB device automatically.

### Remove the USB device

- 1 Press **⏻** to turn off the unit.
- 2 Remove the USB device.

### Insert a card

**Note**

- This unit supports SD, SDHC, and MMC cards.

- 1 Press **⏻** to release the panel.
- 2 Insert the card into the card slot.
  - ↳ The unit starts playing from the card automatically.

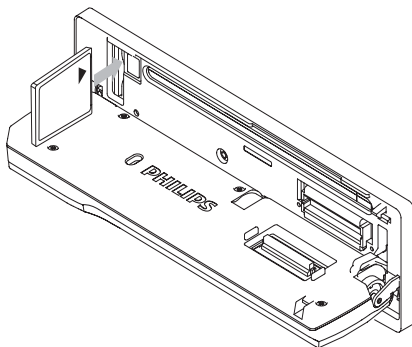

### Remove the card

- 1 Press **⏻** to turn off the unit.
- 2 Press the card until you hear a click sound.
  - ↳ The card is now disengaged.
- 3 Remove the card.

## Control play

- To select a folder, press **▲** or **▼**.
- To skip to the previous/next track, press **⏮** or **⏭**.
- To search backward/forward rapidly within the current track, press **⏮** or **⏭** for 3 seconds.
- To pause, press **⏸**.
- To resume play, press **⏸** again.

## Search for an MP3/WMA track

- 1 Press **SEARCH** for 3 seconds.
  - ↳ Search menu is displayed.
  - ↳ **[FILE]**: search by track name.
  - ↳ **[FOLDER]**: search by folder sequence.
- 2 Turn **⏻** to select **[FILE]** and then press **⏻** to confirm.
- 3 Turn **⏻** to enter a character and then press **⏻**.
- 4 Repeat step 3 until the search term is complete.
- 5 Press **⏻** for 3 seconds to start search.
  - ↳ When search is finished, a list of matching tracks are displayed.
- 6 Turn **⏻** to skip over the list.
- 7 Press **⏻** to select a track.

## View play information

- 1 During play USB/SD/MMC device, press **MENU/DISP** repeatedly to view:
  - Track number and elapsed play time
  - Artist
  - Album
  - Title
  - Folder
  - File
  - Clock

---

## Intro play

You can play the first 10 seconds of each track.

- 1 During play, press **INTRO, 2** to select:
  - **[INT ON]** : After the first 10 seconds of each track have been played, play stops.
  - **[INT OFF]** : Cancel intro play and start normal play.

---

## Shuffle play

You can play the tracks in random order.

- 1 During play, press **SHUF, 4** to select:
  - **[SHUF ON]**: start shuffle play for all tracks.
  - **[SHUF OFF]**: cancel shuffle play.

---

## Repeat play

- 1 During play, press **3, REP** repeatedly to select:
  - **[RPT 1]** (repeat one track): play the current track repeatedly.
  - **[RPT FOLD]** (repeat a folder): play all tracks in the current folder repeatedly.
  - **[RPT ALL]** (repeat all tracks): play all tracks repeatedly.

---

## Connect external sound source

- 1 Connect the external sound source to **MP3 LINK** socket with a 3.5 mm cable.
- 2 Press **SOURCE** repeatedly until **[MP3 LINK]** is displayed.
- 3 Operate the external component (refer to the instructions supplied with the external component).

## 6 Adjust sound

### Adjust volume

- 1 Turn  $\odot$  clockwise/anticlockwise to increase/decrease volume.

### Mute

You can turn off the sound of your audio.

- 1 During play, press **MUTE** $\odot$ .
  - To turn the sound back on, press **MUTE** $\odot$  again.

### Turn Dynamic Bass Boost (DBB) on/off

- 1 Press **DBB** for 3 seconds, the current setting is displayed:
  - ↳ **[DBB ON]**: The Dynamic Bass Boost (DBB) function is on.
  - ↳ **[DBB OFF]**: The DBB function is off.
- 2 Press **DBB** again for 3 seconds to change the DBB setting.

### Select preset equalizer

- 1 Press **EQ/Audio**.
  - ↳ The current Equalizer setting is displayed.
- 2 Press **EQ/Audio** again repeatedly to select a preset EQ:
  - **[USER]** (user)
  - **[FLAT]** (flat)
  - **[POP]** (pop)
  - **[TECHNO]** (techno)
  - **[ROCK]** (rock)
  - **[CLASSIC]** (classic)
  - **[JAZZ]** (jazz)
  - **[OPTIMAL]** (optimal)

### Other sound settings

You can also edit user preset EQ.

- 1 Press **EQ/Audio** for 3 seconds.
- 2 Press  $\blacktriangle$  or  $\blacktriangledown$  repeatedly to select the item to be adjusted:
  - **[BAS]** (bass) range: -7 to +7.
  - **[MID]** (bass) range: -7 to +7.
  - **[TRE]** (treble) range: -7 to +7.
  - **[BAL]** (balance) range: 12L to 12R. (L = left speaker, R = right speaker)
  - **[FAD]** (fader) range: 12R to 12F. (R = rear speaker, F = front speaker)
  - **[LPF]** (low pass filter) range: 60, 80, 100, 200.
  - **[MPF]** (mid pass filter) range: 500, 1K, 1.5K, 2.5K.
  - **[HPF]** (high pass filter) range: 10K, 12.5K, 15K, 17.5K.
  - **[SW ON]/[SW OFF]** (subwoofer volume on or off)
  - **[SW VOL]** (subwoofer volume) range: 0 to 15.
- 3 Turn  $\odot$  to select a value.
- 4 Press  $\odot$  to confirm.

## 7 Adjust system settings

---

### Select blackout setting

You can set the screen to turn off automatically after the unit is idle for 10 or 20 seconds.

- 1 Press **MENU/DISP** for 3 seconds.
- 2 Turn  $\odot$  to select a setting:
  - **[BKO 10 S]**: Turn off the screen automatically 10 seconds after last operation.
  - **[BKO 20 S]**: Turn off the screen automatically 20 seconds after last operation.
  - **[BKO OFF]**: Never turn off the screen.
- 3 Press  $\odot$  to confirm.

---

### Turn demo mode on/off

When demo mode is on, when the unit is idle for more than 2 minutes, all functions are displayed.

- 1 Press **MENU/DISP** for 3 seconds.
- 2 Press  $\blacktriangle$  or  $\blacktriangledown$  repeatedly to until **[DEMO]** is displayed.
  - ↳ The screen shows current Demo mode setting.
- 3 Turn  $\odot$  to select a setting:
  - **[DEMO ON]**: Turn on the demo mode.
  - **[DEMO OFF]**: Turn off the demo mode.
- 4 Press  $\odot$  to confirm.

---

### Change button backlight color

You can change button backlight color from green to red or vice versa.

- 1 Press **MENU/DISP** for 3 seconds.
- 2 Press  $\blacktriangle$  or  $\blacktriangledown$  repeatedly to until **[KEY GREEN]** or **[KEY RED]** is displayed.
- 3 Turn  $\odot$  to select a setting:
  - **[KEY GREEN]**: Backlight turns green.
  - **[KEY RED]**: Backlight turns red.

---

### Select start volume

Each time you turn on the unit, it can play at the last listened volume or at the preset volume.

- 1 Press **MENU/DISP** for 3 seconds.
- 2 Press  $\blacktriangle$  or  $\blacktriangledown$  repeatedly to until **[V - LAST]** or **[V - ADJ]** is displayed.
- 3 Turn  $\odot$  to select a setting:
  - **[V - LAST]**: Each time you turn on the unit, the volume remains from its previous use.
  - **[V - ADJ]**: Each time you turn on the unit, the volume is at the preset level.
- 4 Press  $\odot$  to confirm.

---

### Store preset volume

You can turn on the unit at a preset volume.

- 1 Select **[V - ADJ]** as the start volume.
- 2 Press **MENU/DISP** for 3 seconds.
- 3 Press  $\blacktriangle$  or  $\blacktriangledown$  repeatedly to until **[A-VOL]** is displayed.
- 4 Turn  $\odot$  to select a value: 0 - 47.
- 5 Press  $\odot$  to confirm.

## Turn beep sound on/off

Each time you press a button, the unit beeps. You can turn off/on this beep sound.

- 1 Press **MENU/DISP** for 3 seconds.
- 2 Press **▲** or **▼** repeatedly to until **[BEEP ON]** or **[BEEP OFF]** is displayed.
- 3 Rotate **⊖** to select a setting:
  - **[BEEP ON]**: Turn on the beep sound.
  - **[BEEP OFF]**: Turn off the beep sound.
- 4 Press **⊖** to confirm.

## Turn display scroll on/off

For track information that is longer than the display panel: you can select to cut off the remainder of the text, or scroll to display the full text.

### Note

- If any special characters are present in the MP3 track name or album name, it may not display correctly on the screen because these characters are not supported.
- Some WMA is protected by Digital Rights Management (DRM), it cannot be played on the unit.
- Folders/files exceed the supported limit of the unit are not displayed or played.

- 1 Press **MENU/DISP** for 3 seconds.
- 2 Press **▲** or **▼** repeatedly to until **[ROLL ON]** or **[ROLL OFF]** is displayed.
- 3 Turn **⊖** to select a setting:
  - **[ROLL ON]** (scroll on): Auto scroll during play.
  - **[ROLL OFF]** (scroll off): No auto scroll display.
- 4 Press **⊖** to confirm.

## Select shock-protect setting

You can select the shock protection setting, depending on the stability of your car and the condition of the road.

- 1 Press **MENU/DISP** for 3 seconds.
- 2 Press **▲** or **▼** repeatedly until **[ESP]** is displayed.
- 3 Turn **⊖** to select a setting:
  - **[ESP 12]**: select this when the road is smooth and there are few bumps.
  - **[ESP 45]** select this when the road is bumpy and unstable.
- 4 Press **⊖** to confirm the selection.

## Reset

You can reset the unit to its default setting.

- 1 Detach the front panel (see 'Detach the front panel' on page 25).
- 2 Press the reset button by using a ball-point pen or a similar tool.
  - ↳ Preset adjustments such as preset channels and sound adjustments are erased.

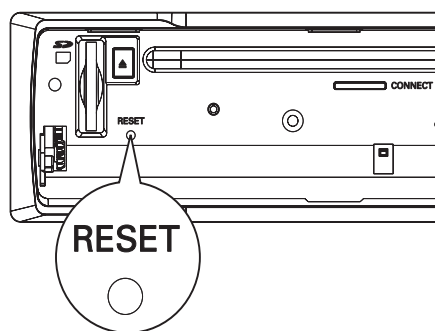

## 8 Additional information

### Detach the front panel

You can detach the front panel to deter theft.

- 1 Press  to release the panel.
- 2 Press the left side of the panel rightward.

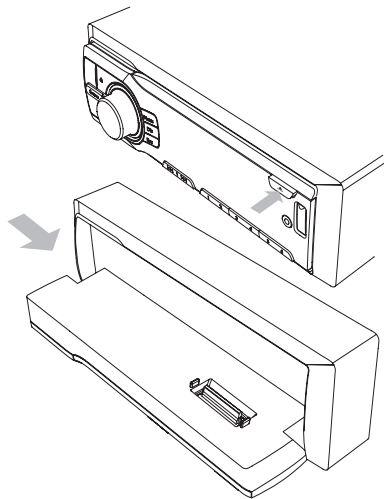

- 3 Pull the panel towards you to detach it from the chassis.
- 4 Store the panel in the supplied carry case to protect it from dirt or damage.

### Replace fuse

If the fuse is damaged,

- 1 Check the electric connection.
- 2 Buy a fuse that matches the voltage of the damaged fuse.
- 3 Replace the fuse.

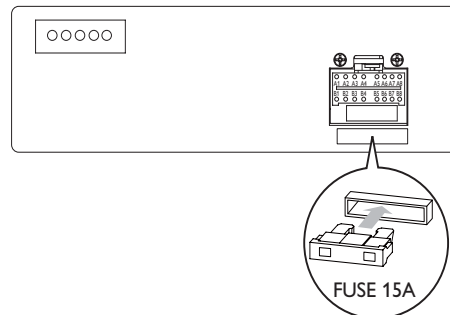

#### Note

- If the new fuse gets damaged again, there may be an internal malfunction. Consult your Philips dealer.

### Remove the unit

You can remove the unit from the dashboard.

- 1 Detach the front panel.
- 2 Pull out the unit by using the removal keys.

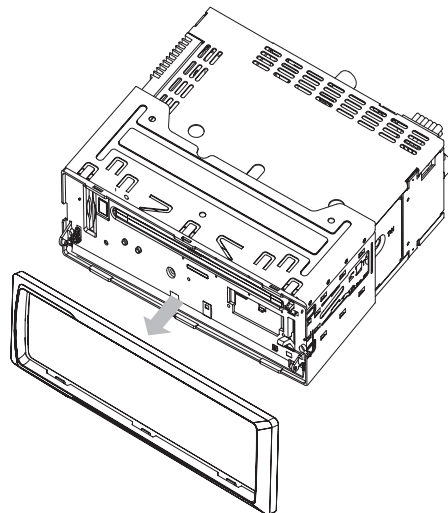

## 9 Product information

### Note

- Product information is subject to change without prior notice.

Power supply	12 V DC (11 V - 16 V), negative ground
Fuse	15 A
Suitable speaker impedance	4 - 8 Ω
Maximum power output	50 W × 4 channels
Continuous power output	24 W × 4 channels (4Ω 10% T.H.D.)
Pre-Amp output voltage	2.0 V ( USB play mode; 1 kHz, 0 dB, 10 kΩ load)
Subwoofer output voltage	2.0 V (USB play mode: 61 Hz, 0 dB, 10 kΩ load)
Aux-in level	≥ 300 mV
Dimensions (W × H × D)	188 × 58 × 190M
Weight	1.0 kg
Operating temperature range	-20°C ~ 70°C

### Radio

Frequency range	
- FM	87.5 - 108.0 MHz
- OIRT	65 - 74 MHz
Frequency range	
- AM(MW)	522 - 1620 KHz
Usable sensitivity	8 μV
- FM	
Usable sensitivity - AM(MW) (S/N = 20 dB)	30 μV

### Compatible USB devices:

- USB flash memory (USB 2.0 or USB1.1)
- USB flash players (USB 2.0 or USB1.1)
- memory cards (SD / MMC / SDHC)

### Supported formats:

- USB or memory file format: FAT16, FAT32
- MP3 bit rate (data rate): 32-320 Kbps and variable bit rate
- WMA v9 or earlier
- Directory nesting up to a maximum of 8 levels
- Number of albums/ folders: maximum 99
- Number of tracks/titles: maximum 999
- ID3 tag v2.0 or later
- File name in Unicode UTF8 (maximum length: 128 bytes)

### Unsupported formats:

- Empty albums: an empty album is an album that does not contain MP3/ WMA files, and is not be shown in the display.
- Unsupported file formats are skipped. For example, Word documents (.doc) or MP3 files with extension .dlf are ignored and not played.
- AAC, WAV, PCM audio files
- DRM protected WMA files (.wav, .m4a, .m4p, .mp4, .aac)
- WMA files in Lossless format
- ISO9660, Joliet
- Maximum title number: 512 (depending on file name length)
- Maximum album number: 255
- Supported sampling frequencies: 32 kHz, 44.1kHz, 48 kHz
- Supported Bit-rates: 32~256 (kbps), variable bit rates



# 10 Troubleshooting

## Caution

- Never remove the casing of this apparatus.

To keep the warranty valid, never try to repair the system yourself.

If you encounter problems when using this apparatus, check the following points before requesting service. If the problem remains unsolved, go to the Philips web site ([www.philips.com/support](http://www.philips.com/support)). When you contact Philips, ensure that your apparatus is nearby and the model number and serial number are available.

### No power or no sound.

- Car engine is not on. Turn the car engine on.
- Cable is not correctly connected. Check connections.
- Fuse is burnt. Replace fuse (see 'Replace fuse' on page 25).
- Volume is too low. Adjust volume (see 'Adjust volume' on page 22).
- If the above solutions cannot help, press the RESET button.
- Ensure that the track played is of a compatible format.

### Noise in broadcasts.

- Signals are too weak. Select other stations with stronger signals.
- Check the connection of the car antenna.
- Change broadcast from Stereo to mono (see 'Select stereo/mono broadcasting' on page 16).

### Cannot play disc

- Ensure that the disc label is inserted with the printed side facing up.
- Wipe the disc with fibre cleaning cloth from the centre to the edge in a straight line.
- This disc may be defective. Play another disc.

- Ensure that the CD is a finalised CD/CD-R/CD-RW.
- Ensure that the CD is not encoded with copyright protection technologies.

### The CD skips tracks

- Ensure that the CD is not damaged or dirty.
- Ensure that random mode is deactivated.

### Disc cannot be ejected

- Press and hold ▲

### Preset stations lost.

- Battery cable is not correctly connected. Connect the battery cable to the terminal that is always live.

### Display show ERR-12

- USB/SD/MMC data error. Check the USB device or SD/MMC card.

# 11 Glossary

---

## M

### MMC

MultimediaCard. A type of memory card with a flash memory.

### MP3

A file format with a sound data compression system. MP3 is the abbreviation of Motion Picture Experts Group 1 (or MPEG-1) Audio Layer 3. With the MP3 format, one CD-R or CD-RW can contain about 10 times more data than a regular CD.

## R

### RDS (Radio Data System)

RDS tuners can automatically tune in stations according to the types of music (or talk) they broadcast. RDS also enables a receiver to display text messages and even graphics (usually call letters and format information) that many FM stations include on a sub-carrier signal within their normal broadcast signal. Some RDS equipped tuners can even override with traffic alerts or emergency broadcasts, during playback of other media - CD MD, or cassette. There are other useful features too, many of which are offered by the growing number of RDS stations.

### Region code

A system that allows discs to be played only in the region designated. This unit only plays discs that have compatible region codes. You can find the region code of your unit on the product label. Some discs are compatible with more than one region (or ALL regions.)

## S

### SD

Secure Digital. A type of memory card with a flash memory.

### SDHC

Secure Digital High Capacity (SDHC) is a type of flash memory card based on the SDA 2.00 specification. The SDA 2.00 specification enables SD cards to reach higher capacities from 4GB to 32GB, and growing.

## W

### WMA (Windows Media Audio)

An audio format owned by Microsoft, is a part of Microsoft Windows Media technology. Includes Microsoft Digital Rights Management tools, Windows Media Video encoding technology, and Windows Media Audio encoding technology.



© 2009 Koninklijke Philips Electronics N.V.  
All rights reserved.  
Document order number: CEM220\_51\_UM\_V2.2

