

Always there to help you

Register your product and get support at
www.philips.com/support

SRP2018

Question?
Contact
Philips



User manual

PHILIPS

Contents

| | | |
|----------|--|-----------|
| 1 | Your universal remote | 2 |
| | Introduction | 2 |
| | Overview of the universal remote | 2 |
| | Supported devices | 3 |
| <hr/> | | |
| 2 | Get started | 4 |
| | Insert batteries (not included) | 4 |
| | Set up the universal remote | 5 |
| <hr/> | | |
| 3 | Notice | 9 |
| | Disposal of your old product and battery | 9 |
| <hr/> | | |
| 4 | Service and support | 10 |
| | Frequently asked questions | 10 |
| | Need help? | 10 |

1 Your universal remote

Congratulations on your purchase, and welcome to Philips! To fully benefit from the support that Philips offers, register your product at www.philips.com/welcome

Introduction

With the universal remote, you can operate up to 8 different devices.

Overview of the universal remote

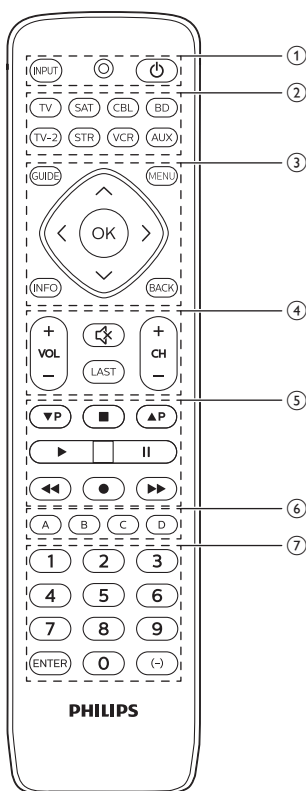

- ① **INPUT**: select available source inputs (antenna, cable, etc.).
 - : LED indicator
 - ⏻ : power on or off.
- ② Device selection buttons

- ③ **GUIDE**: displays the program guide.
INFO: displays on-screen channel information.
MENU: menu on or off.
BACK: exit from the menu.
OK: confirm your selection.
 $\wedge / \vee / \langle / \rangle$: up/down/left/right.
- ④ **VOL+/-**: adjust the volume.
CH+/CH-: go to the next/previous channel.
 🔇 : mute
LAST: return to the previous tuned channel.
- ⑤ **▼P** : previous page
 \blacksquare : stop
▲P : next page
 \blacktriangleright : play
II : pause
 \blacktriangleleft : rewind
 \bullet : record
 \blacktriangleright : fast forward
- ⑥ **A/B/C/D**: context sensitivity buttons (A - yellow, B - blue, C- red, D - Green)
- ⑦ Digit buttons
ENTER: confirm the digit button selection.
 (-): select between one and two-figure channel numbers.

Supported devices

| Device name | Description |
|-------------|---|
| TV/TV-2 | TV, DTV |
| CBL/SAT | Cable box, satellite receiver, IPTV, DVR, HDTV decoder and TiVo |
| BD | DVD player/recorder, Blu-ray player |
| STR | Streaming devices, Apple TV, Roku, Sony, WD TV, Netgear |
| VCR | Video cassette player/ recorder |
| AUX | Auxiliary equipment, media center PC, others |

2 Get started

Insert batteries (not included)

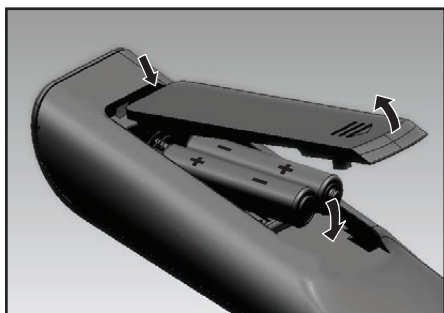

Warning

- Check the battery polarity when inserting in the battery compartment. Incorrect polarity may damage the product.



Caution

- Risk of explosion! Keep batteries away from heat, sunshine or fire. Never discard batteries in fire.
- Risk of decreased battery life! Never mix different brands or types of batteries.



Note

- When you replace the batteries, all user settings will be retained in the memory of the universal remote for 5 minutes.

Set up the universal remote

You must first set up the universal remote before operating your devices.

Manual registration

- 1 Switch on your device.

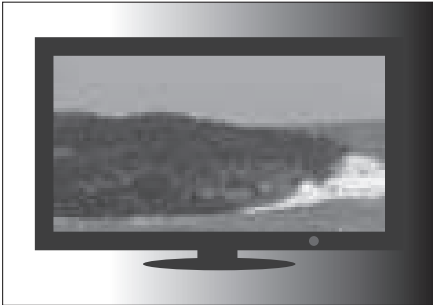

- 2 Press and hold the device selection button (e.g. TV) for 5 seconds until the red LED is on.

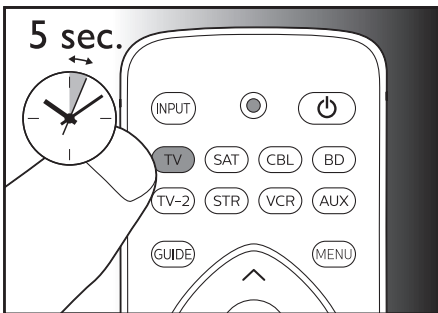

- 3 Look up the 5-digit code for your brand in the code list. Codes are listed by the device type and brand name. The most popular code is listed first.

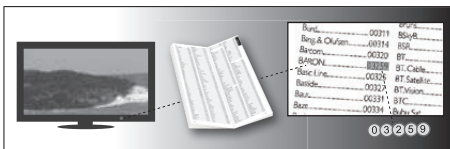

- 4 Enter the first 5-digit code using the digit buttons.

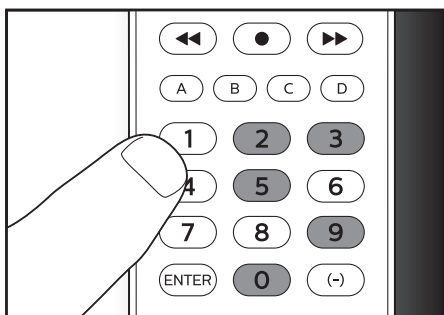

- 5 If the light is off, a valid code is saved. Otherwise, the light will flash once, and then remains on for code re-entry.

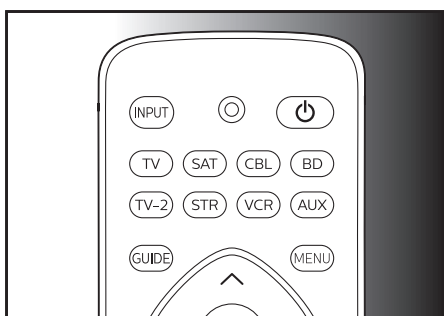

- 6 Operate the device with the universal remote. If your device responds correctly, it means you have entered the right code. Otherwise, repeat from step 2, and enter the second code on the list.

 Note

- It is possible sometimes that your device only responds to some of the buttons. In such case, set up with the next code in the code list, and try operating your device again.
- Each device button can be used to set up any device. E.g. you may setup a TV using the **BD** device button.

Auto registration

- 1 Switch on your device.

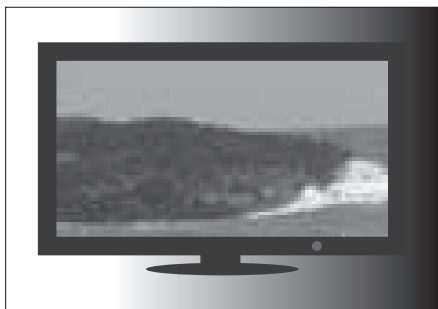

- 2 Press and hold the device selection button (e.g. TV) for 5 seconds until the red LED is on.



- 3 Point at your device with the universal remote. Then press and release  to start searching the code for your brand. A different infrared signal is sent every 2 seconds as the universal remote searches, indicated by a red flash.

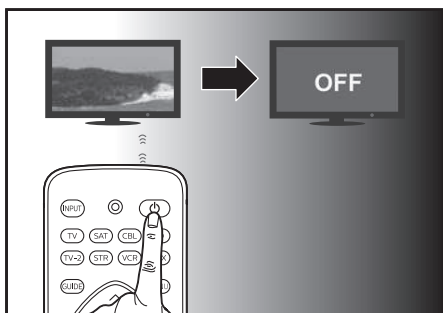

- 4 When the device is off, **immediately** press and release **OK** to save the code. The red LED indicator will turn off.

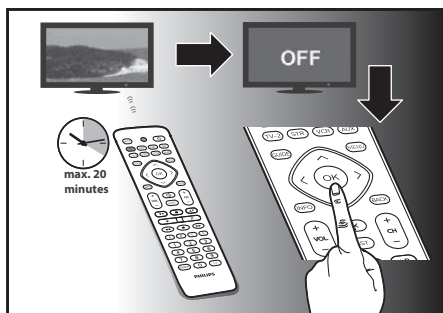

- 5 Operate the device with the universal remote. If your device responds correctly, it means you have saved the right code.



Note

- Auto registration can be reversed, by pressing and releasing **⏻** once more during the auto registration process. This is helpful if you missed out the chance to press **OK** within 2 seconds. Make sure that the device is first powered on again.
- Repeat the same procedures to set up other devices.
- It is possible sometimes that your device only responds to some of the buttons. In such case, set up with the next code in the code list, and try operating your device again.

3 Notice

Notice of compliance

Notice for US

This set complies with the FCC rules, Part 15 and with 21 CFR 1040.10. Operation is subject to the following two conditions:

- ① This device may not cause harmful interference, and
- ② This device must accept any interference received, including interference that may cause undesired operation.

FCC rules

This equipment has been tested and found to comply with the limits for a Class B digital device, pursuant to part 15 of the FCC Rules. These limits are designed to provide reasonable protection against harmful interference in a residential installation. This equipment generates, uses and can radiate radio frequency energy and, if not installed and used in accordance with the instruction manual, may cause harmful interference to radio communications.

However, there is no guarantee that interference will not occur in a particular installation. If this equipment does cause harmful interference to radio or television reception, which can be determined by turning the equipment off and on, the user is encouraged to try to correct the interference by one or more of the following measures:

- Relocate the receiving antenna.
- Increase the separation between equipment and receiver.
- Connect the equipment into an outlet on a circuit different from that to which the receiver is connected.
- Consult the dealer or an experienced radio/TV technician for help.

FCC Radiation Exposure Statement:

This equipment complies with FCC radiation exposure limits set forth for an uncontrolled environment. This equipment should be installed and operated with a minimum distance of 20cm between the radiator and your body. This transmitter must not be co-located or operated in conjunction with any other antenna or transmitter.

Warning: Changes or modifications made to this equipment not expressly approved by Gibson Innovations may void the FCC authorization to operate this equipment.

Model number: SRP2018

Trade Name: Philips

Responsible party: Gibson Innovations USA Inc. 3070 Windward Plaza Suite F, Box 735 Alpharetta, GA 30005

Notice for Canada:

This device complies with Industry Canada licence-exempt RSS standard(s). Operation is subject to the following two conditions: (1) this device may not cause harmful interference, and (2) this device must accept any interference received, including interference that may cause undesired operation.

This Class B digital apparatus complies with Canadian ICES-003.

IC Radiation Exposure Statement:

This equipment complies with Canada radiation exposure limits set forth for uncontrolled environments.

This transmitter must not be co-located or operating in conjunction with any other antenna or transmitter.

Disposal of your old product and batteries

Your product is designed and manufactured with high quality materials and components, which can be recycled and reused.

Never dispose of your product with other household waste. Please inform yourself about the local rules on the separate collection of electrical and electronic products and batteries. The correct disposal of these products helps prevent potentially negative consequences on the environment and human health.

Your product contains batteries, which cannot be disposed of with normal household waste.

Please inform yourself about the local rules on separate collection of batteries. The correct disposal of batteries helps prevent potentially negative consequences on the environment and human health.

Please visit www.recycle.philips.com for additional information on a recycling center in your area.

Environmental information

All unnecessary packaging has been omitted. We have tried to make the packaging easy to separate into three materials: cardboard (box), polystyrene foam (buffer) and polyethylene (bags, protective foam sheet.)

Your system consists of materials which can be recycled and reused if disassembled by a specialized company. Please observe the local regulations regarding the disposal of packaging materials, exhausted batteries and old equipment.

4 Service and support

Frequently asked questions

My universal remote does not work at all.

- Check if you have correctly setup the device with the right code.
- Check if you have pressed the corresponding device key for your device.
- Check if the batteries are inserted properly. If the battery level is low, replace the batteries.
- Check if your device is powered on.

If several device codes are listed under the brand of my device, how can I select the correct device code?

To seek the correct device code, test the codes one by one. The codes are sorted by popularity, and the most popular code is listed first.

My device responds only to some of the commands.

You have set a code for which only some commands work properly but some do not. Try other codes until most keys work properly.

Need help?

We advise you to first read this user manual carefully. It helps you set up and use the universal remote.

If, however, you require extra information or have additional questions about setup, usage, warranty, etc of the SRP2018, you can always contact us.

When calling our helpline, make sure to have the SRP2018 at hand when you call, so that our operators can help you determine whether SRP2018 is working properly.

You will find our contact details at the end of this user manual.

For online support, visit www.philips.com/support



2016 © Gibson Innovations Limited. All rights reserved.

This product has been manufactured by, and is sold under the responsibility of Gibson Innovations Ltd., and Gibson Innovations Ltd. is the warrantor in relation to this product.

Philips and the Philips Shield Emblem are registered trademarks of Koninklijke Philips N.V. and are used under license from Koninklijke Philips N.V.

UM_SRP2018_27_EN_V1.0
WK16094

