

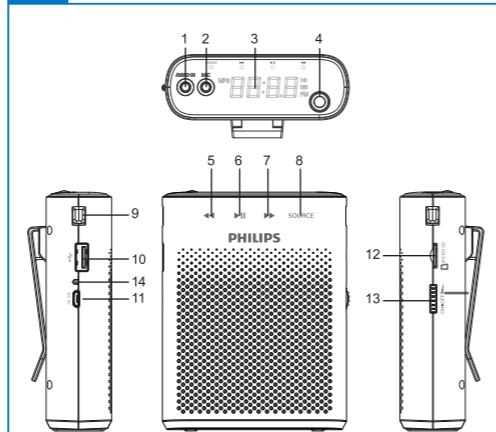

EN Before using your product, read all accompanying safety information.

ZH-CN 使用产品之前, 请先阅读所有随附的安全信息。



- | | |
|--------------------|----------------------------------|
| 1. AUDIO IN 音频输入插孔 | 10. USB 插孔 (仅用于U盘播放, 不能用于充电) |
| 2. MIC IN 麦克风输入插孔 | 11. MICRO USB 插孔 |
| 3. DISPLAY 显示屏 | 12. TF CARD 插孔 |
| 4. ANTENNA收音天线 | 13. POWER ON/OFF VOL+- 开关/音量大小调节 |
| 5. ◀收音手动选台减/上一曲 | 14. CHARGING INDICATOR 充电指示灯 |
| 6. ▶ 播放/暂停 | |
| 7. ▶▶收音手动选台加/下一曲 | |
| 8. SOURCE 信号源输入选择 | |
| 9. HOOK 金属挂钩 | |

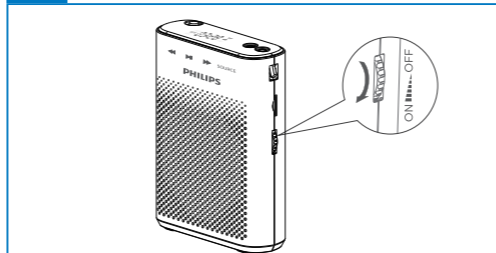

EN **Power On/Off**
Rotate the volume knob clockwise/anticlockwise to turn the speaker on or off.

Tips: When the speaker is not connected with any signal source and there is no operation for 15 minutes. The speaker will automatically enter into power-saving mode. You need to switch the knob off and then switch on to wake up the speaker.

ZH-CN 开机和关机
OFF档 关机 / ON档 开机
依次旋转 音量不断加大

温馨提示: 当扩音器没有接入任何信号源, 且15分钟无任何操作时会自动进入省电模式。如需唤醒, 需将开关旋钮关机后再开。



EN **REC**
EN Preparation for Recording
1. Connect the wired headset microphone to the MIC slot.
2. Insert a USB flash disk or a TF card into the speaker.
Tips: The wired headset microphone needs to be purchased separately.

ZH-CN 录音前的准备
1. 有线麦克风插入MIC接口内
2. 机器上必须要有U盘或TF卡
温馨提示: 有线麦克风需另行购买



EN **Recording Procedure**
1. Press SOURCE key to switch to Recording Mode(as shown in Fig.1.2)
2. Press ▶|| to start recording(as shown in Fig.3.4)
3. Long press ▶|| to end recording and store the audio file into the USB flash disk or TF card(as shown in Fig.5)
4. Listen to your recordings: Press SOURCE key to switch to MP3 mode, press ◀◀ to listen to your latest recording. (as shown in Fig.6.7.8)

ZH-CN 录音步骤
1. 按SOURCE切换到REC模式, 此时显示屏会出现图(详见图1、2)
2. 按下 ▶|| 键开始录音, 显示屏会出现0001, 0002 (详见图3、4)
3. 结束录音并保存, 长按 ▶|| 键2秒, 录音文件会保存到U盘或TF卡中 (详见图5)
4. 播放录音: 按SOURCE键切换到MP3模式下, 按 ◀◀ 键即可完成播放最后一次录音的文件 (详见图6、7、8)

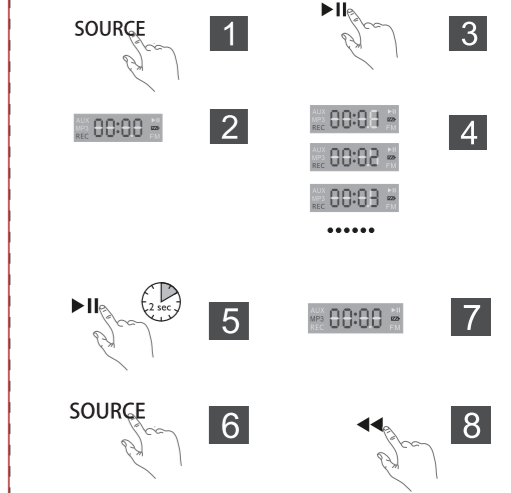

EN **FM Radio Mode Instructions**
Search FM Radio stations automatically: Short press SOURCE key to select FM source. When you enter FM radio mode for the first time, press and hold ▶|| key for two seconds to scan and save stations automatically. Press ◀◀ or ▶▶ to switch to previous or next station.
Search FM Radio stations manually: In FM Radio Mode, press and hold ◀◀ or ▶▶ key for two seconds. When the display frequency is blinking, press ◀◀ or ▶▶ to switch to your favorable station, press ▶|| key to save it. Press and hold ▶|| key for 2 seconds to exit.

Clear the radio station: In FM mode, long press SOURCE button for 5 seconds, it will clear all radio stations, and at the same time there will be voice prompts

ZH-CN FM收音机模式搜台说明
自动搜台: 短按SOURCE键进入FM模式, 当用户首次进入FM模式, 要长按 ▶|| 键2秒, 会有语音提示进行自动搜台, 搜台完成后, 自动保存电台, 短按 ◀◀ 或 ▶▶ 进行电台切换。
手动搜台: 收音机模式下, 长按 ◀◀ 或 ▶▶ 2秒, 当显示屏电台频率闪动, 表示已经进入手动搜台中, 再短按 ◀◀ 或 ▶▶ 调到你想听的频率后, 短按 ▶|| 键, 保存当前频率电台, 如果想放弃当前频率或者退出手动搜台, 长按 ▶|| 2秒就立即返回。
清除电台: 在FM模式下, 长按SOURCE键5秒, 会自动清除所有电台, 同时有语音提示。

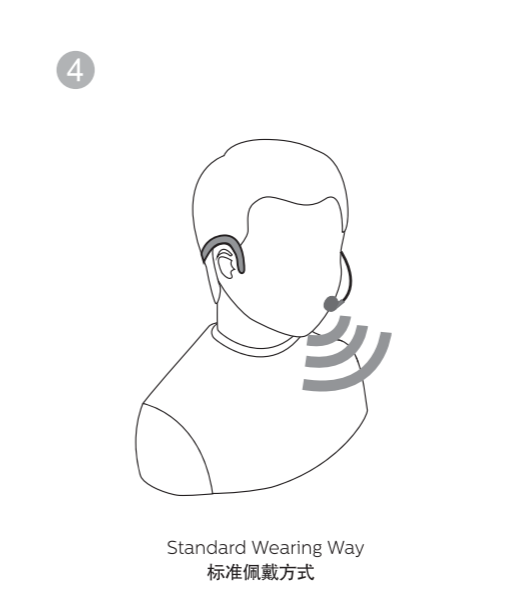
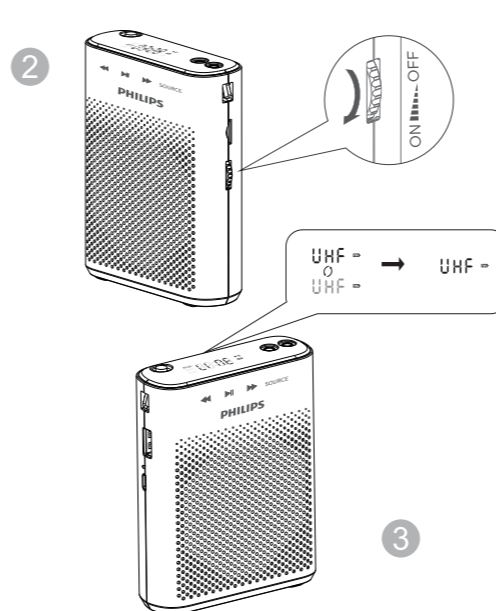
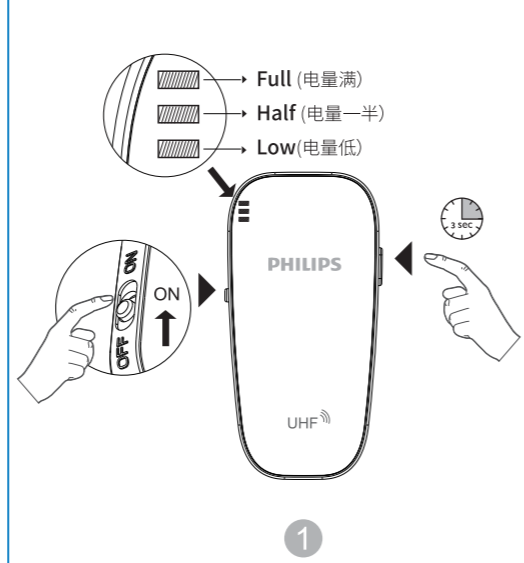

EN **UHF Wireless Microphone Instructions**
1. When first time pairing. Turn on the UHF wireless microphone, press and hold PAIR key for 5-6 seconds, after blinking blue, UHF enters the pairing search (as shown in Fig.1), and then power on the speaker(as shown in Fig.2), when the UHF icon on display keep solid from blinking means paired successfully (as shown in Fig.3). Now you can wear the UHF wireless microphone to speak (as shown in Fig.4). Please adjust the volume to avoid howling according to the space of environment.
2. Once paired successfully, next time, the UHF microphone will pair automatically when power on. Please refer to the step 1 above when there is a new UHF wireless microphone or new speaker.
3. When there are many people using same device in the same place, occasionally appear string frequency phenomenon, or can not connect, press PAIR key on the microphone for the frequency changes.
4. Charging instructions of UHF wireless microphone. Blinking orange while battery low, please charge in time. Solid red while charging, and red off after full charged. (Lock Touch Key: double press the SOURCE key quickly to lock the touch operation. You will hear a voice prompt. Unlock Touch Key: double press the SOURCE key again to unlock the touch operation. You will hear twice voice prompt. The touch key will be automatically locked after 20 seconds with no operation in the wireless or wireless microphone mode.)

ZH-CN UHF无线麦克风使用说明
1. 第一次配对, 先打开UHF无线麦克风, 长按PAIR键5-6秒, 待蓝灯快速闪烁后, UHF进入配对搜索中 (如图1) 再打开扩音器电源开关 (如图2), 待显示屏上的UHF图标, 从闪动状态变成静止常亮状态时, 表示配对成功 (如图3), 此时可以戴上UHF无线麦克风进行喊话扩音 (如图4)。可根据周围环境空间的大小, 调节扩音器的音量大小, 以免产生啸叫。
2. 第一次配对后, 后续开机会自动连接, 无需再次配对。如果出现新UHF无线麦克风或新扩音器, 请参照第一条配对。
3. 当同一地方有多人使用同型号产品时, 偶尔出现串频现象连接不上, 此时请短按无线麦克风上的PAIR键进行换频。
4. UHF无线麦克风充电说明
当无线麦克风电量不足时, 电池电量橙色灯快速闪烁, 请用户及时充电, 充电时: 红灯常亮; 充满电时: 红灯熄灭。(锁住按键: 快速双击SOURCE键; 语音提示一声表示锁住按键。解锁按键: 快速双击SOURCE键; 语音提示两声表示解锁按键。在无线麦克风与有线麦克风模式下无操作20秒后会自动锁住按键。)

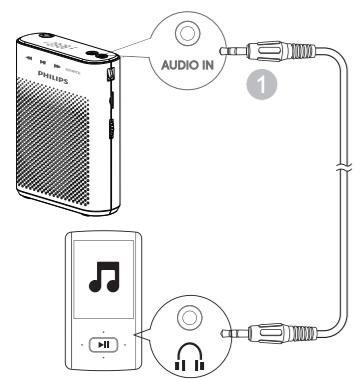

EN

AUDIO IN Mode
Connect your Audio in cable to the AUDIO IN socket, there will be voice prompts and the speaker will enter into the AUDIO IN mode automatically.

ZH-CN

AUDIO IN 模式
当音频线插入AUDIO IN插孔，扩音器会自动切换AUDIO IN模式，同时有语音提示。



EN

Bluetooth Mode Instructions
1. Press SOURCE key to switch to Bluetooth pairing mode. The bLUE icon blinking on the screen and there is a voice prompt.
2. Activate Bluetooth of your phone or device, scan for "Philips SBM230", click and connect successfully, the bLUE icon keep solid on the screen, and there is a voice prompt that the Bluetooth is connected.

ZH-CN

蓝牙模式
1. 按SOURCE键切换到蓝牙模式，显示屏显示bLUE图标并闪动，同时有语音提示蓝牙配对中。
2. 打开手机或设备的蓝牙，搜索“Philips SBM230”，点击配对连接后，显示屏bLUE图标常亮，并有语音提示蓝牙已连接。

Specifications

Rated Output Power	3W RMS
Signal to Noise Ratio	50dBA
Aux Input	600mV RMS, 22 kohm
Power Supply	5V == 0.5A
Built-in Battery	lithium battery
Dimensions - Main Unit (W x H x D)	90 x 116 x 32 mm
Weight -Main Unit	0.198kg

规格

额定输出功率	3 W RMS
信噪比	50 dBA
Aux 输入	600 毫伏 RMS , 22 千欧
电源	5 伏 == 0.5 安
内置电池	锂电池
尺寸 - 主装置 (宽 x 高 x 厚)	90 x 116 x 32 毫米
重量 - 主装置	0.198 千克



Warning

- Never remove the casing of this apparatus.
- Never lubricate any part of this apparatus.
- Never place this apparatus on other electrical equipment.

Notice

Any Changes or modifications made to this device that are not expressly approved by MMD Hong Kong Holding Limited may void the user's authority to operate the equipment.

Disposal of your old product

Your product is designed and manufactured with high quality materials and components, which can be recycled and reused.

Do not throw away the product with the normal household waste at the end of its life, but hand it in at an official collection point or recycling. By doing this, you help to preserve the environment.



Caution

- Removal of the built-in battery invalidates the warranty and may destroy the product.

Environmental information
All unnecessary packaging has been omitted. We have tried to make the packaging easy to separate into three materials: cardboard (box), polystyrene foam (buffer) and polyethylene (bags, protective foam sheet).

Your system consists of materials which can be recycled and reused if disassembled by a specialized company. Please observe the local regulations regarding the disposal of packaging materials, exhausted batteries and old equipment.



Note

- The type plate is located on the bottom of the apparatus.

简体中文



警告

- 切勿拆下本产品的外壳。
- 切勿润滑本装置的任何部件。
- 切勿将本装置放在其它电器设备上。



注意

- 拆卸内置电池将使保修失效，并可能损坏本产品。

务必让专业人员拆卸产品中的内置电池。

如果电池更换不当会有爆炸危险，只能用同样类型或等效类型的电池来更换，不得暴露在诸如日照、火烤或类似过热环境中。

环境信息
已省去所有不必要的包装。我们努力使包装易于分为三种材料：纸板（盒）、泡沫塑料（缓冲物）和聚乙烯（袋、保护性泡沫片）。
您的系统包含可回收利用的材料（如果由专业公司拆卸）。请遵守当地有关包装材料、废电池和旧设备的处理的规定。



注

- 铭牌（铭牌上的信息包括工作电压）位于主机背面，使用前请先了解铭牌上的相关信息。
- 消费者若使用电源适配器充电，则应购买配套使用获得CCC认证并满足标准要求的电源适配器。

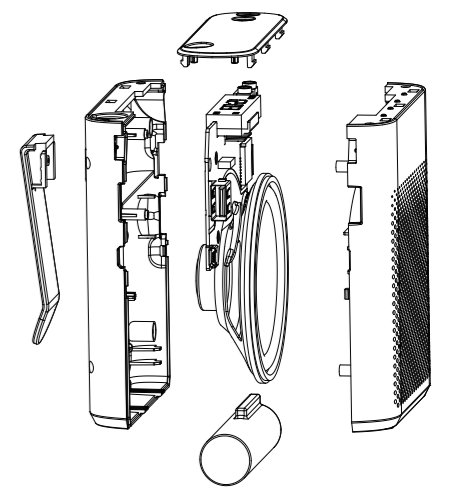

产品中有害物质的名称及含量 Names and Contents of Hazardous Substances

部件名称 Name of the Parts	有害物质 Hazardous Substances					
	铅(Pb, Lead)	汞(Hg, Mercury)	镉(Cd, cadmium)	六价铬(Chromium (VI))	多溴联苯(PBB)	多溴二苯醚(PBDE)
Housing 外壳	0	0	0	0	0	0
Loudspeakers 喇叭单元	0	0	0	0	0	0
PWBs 电路板组件	X	0	0	0	0	0
Accessories (Cables) 附件 (连接线)	X	0	0	0	0	0

本表格依据 SJ/T 11364 的规定编制。
The table is compiled according to SJ/T 11364.

0: 表示该有害物质在该部件所有均质材料中的含量均在 GB/T 26572 标准规定的限量要求以下。
0: Indicates that this hazardous substance contained in all of the homogeneous materials for this part is below the limit requirement in GB/T 26572.

X: 表示该有害物质至少在该部件的某一均质材料中的含量超出 GB/T 26572 标准规定的限量要求。
X: Indicates that this hazardous substance contained in at least one of the homogeneous materials used for this part is above the limit requirement in GB/T 26572.



这标志表示的期间（10年）是电子电气产品中有害物质在正常使用的条件下不会发生外泄或突变，电子电气产品用户使用该电子电气产品不会对环境污染造成严重污染或对其人身、财产造成严重损害的期限。
This logo refers to the period (10 years) during which the hazardous substances in electronic and electrical products will not leak or mutate so that the use of these [substances] will not result in any severe environmental pollution, any bodily injury or damage to any assets.

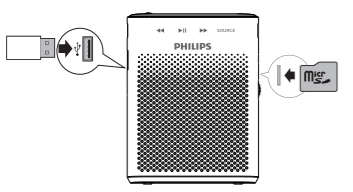

EN

MP3 Mode Instructions
Set loop one/loop all playing: In MP3 mode, the default setting is loop all. If you want to play current track repeatedly, press and hold **▶||** for 2 seconds while playing, and there will be voice prompts to tell you the loop one function has been enabled. To enable the loop all function, press and hold **▶||** for 2 seconds again, there will be voice prompts to tell you the loop all function has been enabled. USB flash disk and TF card support 32GB max. Audio format: support MP3 / WMA / WAV (sampling frequency 8k~48k)

ZH-CN

MP3模式说明
开启单曲/全部循环播放功能：在MP3模式下，默认为全部循环如需进入单曲循环，请长按**▶||**(2秒以上)，会有语音提示单曲循环，再次长按**▶||**(2秒以上)会有语音提示全部循环。U盘与TF卡最大支持容量：32GB，音乐播放格式：支持MP3/WMA/WAV格式（采样8k~48k）。

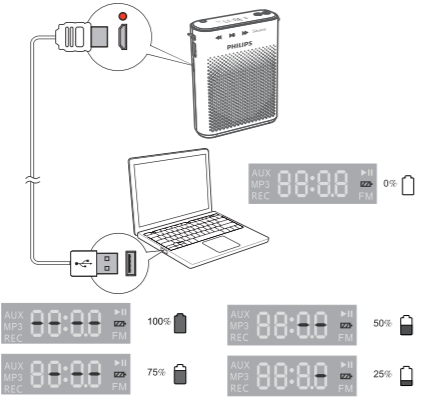

EN

Charging Instructions: Blinking **⚡** continuously while low battery, voice prompts remind you to charge the speaker.
⚡ The Red indicator keep solid while charging, Red indicator off when get fully charged.
It takes around 3 hours to get the battery fully charged.

ZH-CN

充电说明：电量低时**⚡**快闪，并有语音提示及时充电。
⚡ 充电时，充电指示灯红灯常亮，充满后，红灯熄灭。电池从无电到充满状态，大约需要3个小时。

English

Safety

Important Safety Instructions

- Heed all warnings.
- Follow all instructions.
- Do not use this apparatus near water.
- Do not block any ventilation openings. Install in accordance with the manufacturer's instructions.
- Do not install near any heat sources such as radiators, heat registers, stoves, or other devices (including amplifiers) that produce heat.
- Only use attachments/accessories specified by the manufacturer.
- Refer all servicing to qualified service personnel. Servicing is required when the device has been damaged in any way, such as power-supply cord or plug is damaged, liquid has been spilled or objects have fallen into the device, the device has been exposed to rain or moisture, does not operate normally, or has been dropped.
- Devices shall not be exposed to dripping or splashing.
- Do not place any sources of danger on the device (e.g. liquid filled objects, lighted candles).

Always bring your product to a professional to remove the built-in battery.

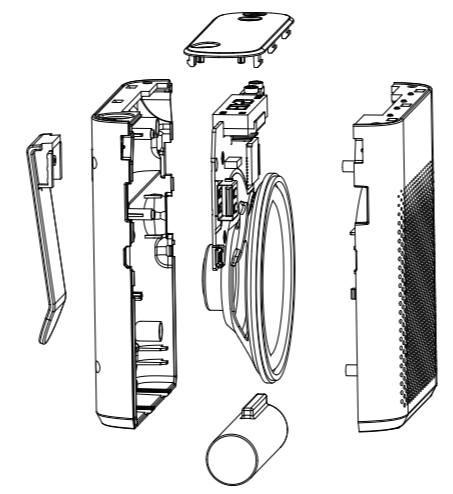

安全

重要安全说明

- 注意所有警告。
- 遵循所有说明。
- 不要在靠近水的地方使用本装置。
- 不要堵塞任何通风口。按照制造商的说明进行安装。
- 不要在任何热源附近安装，如散热器、蓄热器、炉具或其它发热设备（包括功放器）。
- 仅使用制造商指定的附件/配件。
- 所有维修均应由合格的维修人员来执行。本设备有任何损坏时，如电源线或插头损坏，液体泼溅到或物体跌落到设备上，设备淋雨或受潮，无法正常运行，或者跌落均需要进行维修。
- 切勿将本设备暴露在漏水或溅水环境下。
- 不要将任何危险源放在本设备上（例如装有液体的物体、点燃的蜡烛）。

注意

如果用户未经 MMD Hong Kong Holding Limited. 的明确许可而擅自对此设备进行更改或修改，则可能导致其无权操作此设备。

弃置旧产品

本产品采用可回收利用的高性能材料和组件制造而成。弃置产品时，请不要将其与一般生活垃圾一同丢弃，应将其交给政府指定的回收中心或回收。这样做有利于环保。

