

Register your product and get support at  
[www.philips.com/welcome](http://www.philips.com/welcome)

ARG1837



---

EN User manual

---

**PHILIPS**

# Contents

---

<b>1</b>	<b>Important</b>	<b>4</b>
	Safety	4

---

<b>2</b>	<b>Your CD Soundmachine</b>	<b>5</b>
	Introduction	5
	What's in the box	5

---

<b>3</b>	<b>Get started</b>	<b>8</b>
	Connect AC power	8

---

<b>4</b>	<b>Play</b>	<b>9</b>
	Play CD	9
	Play from USB devices	9
	Listen to radio	9
	Play options	9

---

<b>5</b>	<b>Other features</b>	<b>10</b>
	Listen to an external device	10

---

<b>6</b>	<b>Product information</b>	<b>11</b>
	Specifications	11
	Supported MP3 disc formats	11
	USB playability information	11
	Maintenance	12

---

<b>7</b>	<b>Troubleshooting</b>	<b>12</b>
----------	------------------------	-----------

---

<b>8</b>	<b>Notice</b>	<b>13</b>
----------	---------------	-----------

# 1 Important

---

## Safety

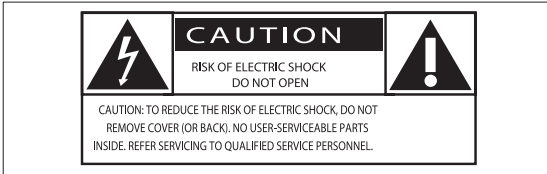

This 'bolt of lightning' indicates uninsulated material within your unit may cause an electrical shock. For the safety of everyone in your household, please do not remove product covering.

The 'exclamation point' calls attention to features for which you should read the enclosed literature closely to prevent operating and maintenance problems.

**WARNING:** To reduce the risk of fire or electric shock, this apparatus should not be exposed to rain or moisture and objects filled with liquids, such as vases, should not be placed on this apparatus.

**CAUTION:** To prevent electric shock, match wide blade of plug to wide slot, fully insert.

---

## Important Safety Instructions

- Follow all instructions.
- Heed all warnings.
- Do not use this apparatus near water.
- Clean only with dry cloth.
- Do not block any ventilation openings. Install in accordance with the manufacturer's instructions.

- Do not install near any heat sources such as radiators, heat registers, stoves, or other apparatus (including amplifiers) that produce heat.
- Protect the power cord from being walked on or pinched, particularly at plugs, convenience receptacles, and the point where they exit from the apparatus.
- Only use attachments/accessories specified by the manufacturer.
- Use only with the cart, stand, tripod, bracket, or table specified by the manufacturer or sold with the apparatus. When a cart is used, use caution when moving the cart/apparatus combination to avoid injury from tip-over.



- Unplug this apparatus during lightning storms or when unused for long periods of time.
- Refer all servicing to qualified service personnel. Servicing is required when the apparatus has been damaged in any way, such as power-supply cord or plug is damaged, liquid has been spilled or objects have fallen into the apparatus, the apparatus has been exposed to rain or moisture, does not operate normally, or has been dropped.
- Apparatus shall not be exposed to dripping or splashing.
- Do not place any sources of danger on the apparatus (e.g. liquid filled objects, lighted candles).
- Where the MAINS plug or an appliance coupler is used as the disconnect device, the disconnect device shall remain readily operable.



### Warning

- Never remove the casing of this apparatus.
- Never lubricate any part of this apparatus.
- Never place this apparatus on other electrical equipment.
- Keep this apparatus away from direct sunlight, naked flames or heat.
- Never look into the laser beam inside this apparatus.
- Ensure that you always have easy access to the power cord, plug or adaptor to disconnect this apparatus from the power.



### Caution

- Use of controls or adjustments or performance of procedures other than herein may result in hazardous radiation exposure or other unsafe operation.

## 2 Your CD Soundmachine

Congratulations on your purchase, and welcome to Philips! To fully benefit from the support that Philips offers, register your product at [www.philips.com/welcome](http://www.philips.com/welcome).

---

### Introduction

With the CD Soundmachine, you can:

- play CDs, MP3/wma discs
- play mp3/wma files on USB devices
- listen to FM/MW (AM) radio
- program the play sequence of tracks.

---

### What's in the box

Check and identify the contents of the package:

- Main unit
- AC power cord
- MP3 LINK cable
- User Manual

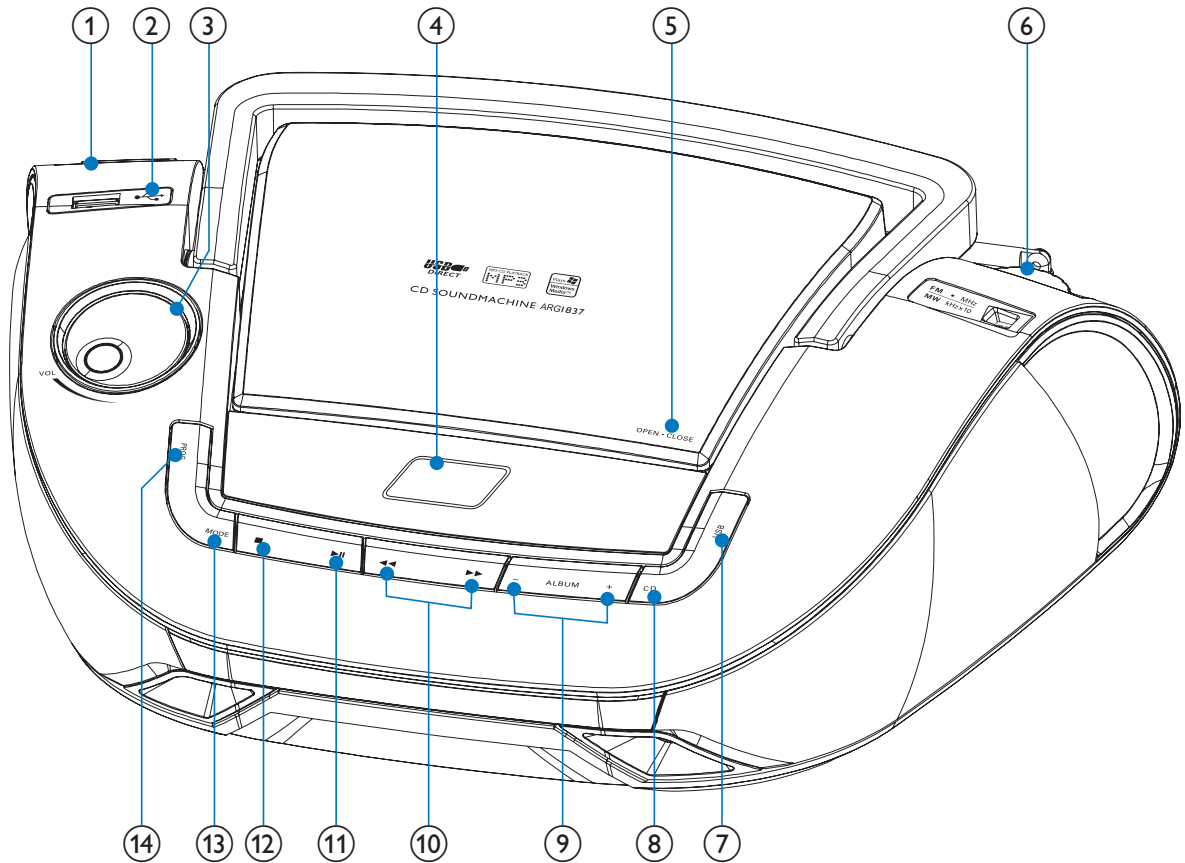

- ① **Source selector: CD•USB, MW (AM), FM, OFF.**
- Select CD•USB, MW (AM), or FM source.
  - **OFF:** switch to standby mode.

- ② 
- USB socket.

- ③ **VOL+/-**
- Adjust volume.

- ④ **Display panel**
- Show current status.

- ⑤ **OPEN•CLOSE**
- Open or close the disc compartment.

- ⑥ **TUNING**
- Tune to radio stations.

- ⑦ **USB**
- Select USB device source.

- ⑧ **CD**
- Select CD source.

- ⑨ **ALBUM+/-**
- For MP3-CDs: Skip to the next/previous album in an MP3-CD.

- ⑩ 
- Select the previous/next track.
  - Search backward/forward.

- ⑪ 
- Start or pause play.

- ⑫ 
- Stop play.
  - Erase a program.

- ⑬ **MODE**
- Select a play mode: REPEAT or SHUFFLE.

- ⑭ **PROG**
- For MP3-CDs: Program tracks and browse the program.

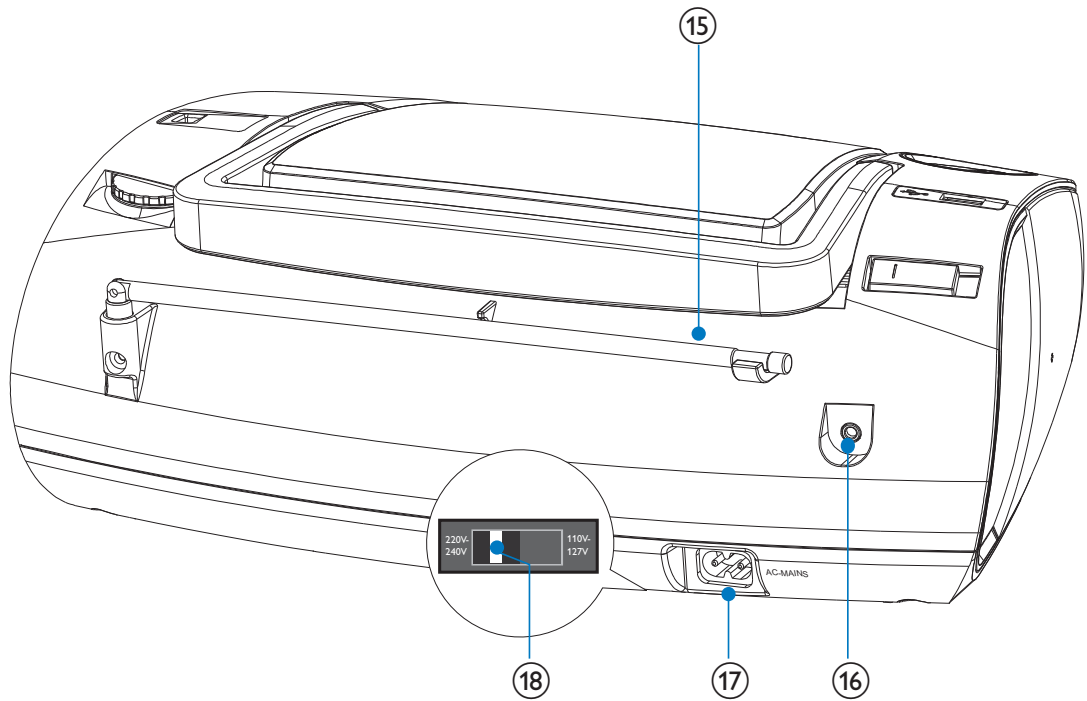

- ⑮ **Telescopic antenna**
  - Adjust FM reception.
- ⑯ **MP3 LINK**
  - Socket for connecting an external device.
- ⑰ **AC~ MAINS**
  - Jack for the supplied AC power cord.
- ⑱ **Voltage selector**
  - Select the local voltage.

# 3 Get started

## ! Caution

- Use of controls or adjustments or performance of procedures other than herein may result in hazardous radiation exposure or other unsafe operation.

Always follow the instructions in this chapter in sequence.

If you contact Philips, you will be asked for the model and serial number of this apparatus. The model number and serial number are on the bottom of the apparatus. Write the numbers here:

Model No. \_\_\_\_\_

Serial No. \_\_\_\_\_

---

## Connect AC power

## ! Caution

- Risk of product damage! Ensure that the power supply voltage corresponds to the voltage printed on the back or the underside of the unit.

## ! Warning

- Risk of electric shock! When you unplug the AC adaptor, always pull the plug from the socket. Never pull the cord.

## ☰ Note

- Install the apparatus near the power supply socket and where the AC power plug can be easily reached.

- 1 Switch the voltage selector at the bottom of the unit to the local power line voltage.

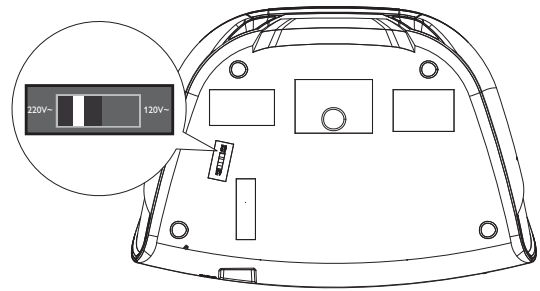

- 2 Connect the power cord to:
  - the **AC~ MAINS** socket on the unit
  - the wall outlet.

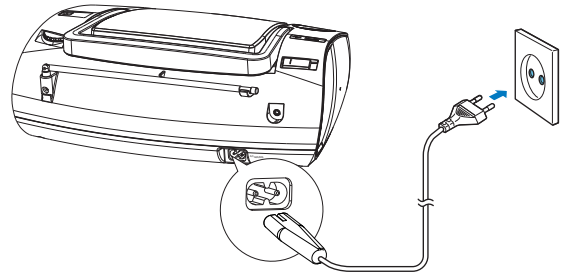

## ✦ Tip

- To save energy: After use, push the source selector to **OFF**.
- To turn off the CD Soundmachine, disconnect the plug from the power supply socket.

# 4 Play

---

## Play CD

You cannot play CDs encoded with copyright protection technologies.

You can play commercially available audio CDs:

- CD-Recordables (CD-R)
- CD-Rewritables (CD-RW)
- MP3-CDs
- WMA-CDs

- 1 Switch the source selector to **CD•USB**.
- 2 Press **CD** to select CD source.
- 3 Press **OPEN•CLOSE** to open the disc compartment.
- 4 Insert a disc with the printed side facing up.
- 5 Press **OPEN•CLOSE** to close the disc compartment.
  - ↳ Play starts automatically.
  - To stop play, press **■**.
  - To pause or resume play, press **▶||**.
  - For MP3/WMA files: to select an album, press **ALBUM +/-**.
  - To skip to a track, press **◀◀ / ▶▶**.
  - To search within a track, press and hold **◀◀ / ▶▶**. Release to resume normal play.

---

## Play from USB devices

### Note

- Make sure that the USB device contains playable audio contents for supported formats.

- 1 Switch the source selector to **CD•USB**.
- 2 Press **USB** to select USB source.
- 3 Insert the USB connector on the device into the  socket.
- 4 Press **- ALBUM +** to select a folder.

- 5 Press **◀◀ / ▶▶** to select a file.

- 6 Press **▶||** to start play.
  - To stop play, press **■**.
  - To pause or resume play, press **▶||**.

---

## Listen to radio

- 1 Switch the source selector to **FM** or **MW**.
- 2 Turn **TUNING** until you find optimal reception.

### Tip

- To improve FM reception, you can extend, incline, or turn the telescopic antenna for best reception.
- To improve MW reception, turn the CD Soundmachine to face a different direction.

---

## Play options

---

### Select play modes

You can choose different play mode.

- 1 Press **MODE** repeatedly to select a play mode:
  - **[ ↻ ]** (repeat) – repeat a track
  - **[ ↻ ALL ]** (repeat all) - repeat an entire CD/program
  - **[ ⌘ ]** (shuffle) - play tracks randomly
- 2 To return to normal play, press **MODE** repeatedly until play mode icons are no longer displayed.

### Tip

- Shuffle play cannot be selected when you play programmed tracks.



---

## Program tracks

You can program a maximum of 20 tracks.

- 1** In CD mode, at the stop position, press **PROG** to activate the program mode.  
↳ **[PROG]** (program) starts to blink.
- 2** For MP3/WMA tracks, press **ALBUM +/-** to select an album.
- 3** Press **◀◀ / ▶▶** to select a track number, and then press **PROG** to confirm.
- 4** Repeat steps 2 to 3 to program more tracks.
- 5** Press **▶||** to play the programmed tracks.  
↳ During play, **[PROG]** (program) is displayed.
  - To erase the program, in the stop position, press **■**.

# 5 Other features

---

## Listen to an external device

You can also listen to an external audio device through this unit.

**For an audio device with a headphone socket:**

- 1** Connect the supplied MP3 LINK cable to
  - the **MP3 LINK** socket on this unit.
  - the headphone socket on an MP3 player.
- 2** Start to play the MP3 player. (See the user manual of the MP3 player.)

# 6 Product information

## Note

- Product information is subject to change without prior notice.

## Specifications

### Disc

Laser Type	Semiconductor
Disc Diameter	12 cm/8 cm
Support Disc	CD-DA, CD-R, CD-RW, MP3-CD, WMA-CD
Total Harmonic Distortion	<1%
Frequency Response	100 Hz -16 kHz

### Tuner

Tuning Range	FM: 87.5-108 MHz; MW: 520-1710 kHz
Total Harmonic Distortion	<3%

### General

Power Supply	120 V~, 60 Hz / 220 V~, 50 Hz;
Sound Output Power	2 x 1 W RMS
Operation Power Consumption	12W
USB	≤ 300 mA
Dimensions	
- Main Unit (W x H x D)	371 x 139 x 262 mm
Weight	
- With Packing	3.4 kg
- Main Unit	2.4 kg

## Supported MP3 disc formats

- ISO9660, Joliet
- Maximum title number: 999 (depending on file name length)
- Maximum album number: 99
- Supported sampling frequencies: 32 kHz, 44.1kHz, 48 kHz
- Supported Bit-rates: 32~256 (kbps), variable bit rates

## USB playability information

### Compatible USB devices:

- USB flash memory (USB1.1)
- USB flash players (USB1.1)
- memory cards (requires an additional card reader to work with this apparatus)

### Supported formats:

- USB or memory file format FAT12, FAT16, FAT32 (sector size: 512 bytes)
- MP3 bit rate (data rate): 32-320 Kbps and variable bit rate
- WMA v9 or earlier
- Directory nesting up to a maximum of 8 levels
- Number of albums/ folders: maximum 99
- Number of tracks/titles: maximum 999

### Unsupported formats:

- Empty albums: an empty album is an album that does not contain MP3/WMA files, and is not be shown in the display.
- Unsupported file formats are skipped. For example, Word documents (.doc) or MP3 files with extension .dlf are ignored and not played.
- AAC, WAV, PCM audio files
- DRM protected WMA files (.wav, .m4a, .m4p, .mp4, .aac)
- WMA files in Lossless format

---

## Maintenance

### Clean the cabinet

- Use a soft cloth slightly moistened with a mild detergent solution. Do not use a solution containing alcohol, spirits, ammonia or abrasives.

### Clean discs

- When a disc becomes dirty, clean it with a cleaning cloth. Wipe the disc from the centre out.

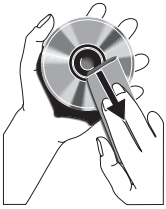

- Do not use solvents such as benzene, thinner, commercially available cleaners, or antistatic spray intended for analogue records.

### Clean the disc lens

- After prolonged use, dirt or dust may accumulate at the disc lens. To ensure good play quality, clean the disc lens with Philips CD lens cleaner or any commercially available cleaner. Follow the instructions supplied with cleaner.

## 7 Troubleshooting



### Warning

- Never remove the casing of this apparatus.

To keep the warranty valid, never try to repair the system yourself.

If you encounter problems when using this apparatus, check the following points before requesting service. If the problem remains unsolved, go to the Philips web site ([www.Philips.com/support](http://www.Philips.com/support)). When you contact Philips, ensure that the apparatus is nearby and the model number and serial number are available.

### No power

- Make sure that the power cord is connected securely.
- Make sure that there is power at the wall outlet.

### No sound

- Adjust the volume.
- Ensure that the track played is of a compatible format.

### Display does not function properly./No reaction to any operation of the controls.

- Disconnect the AC power cord.
- Connect the AC power cord after a few seconds.

### Cannot play disc

- Ensure that the disc label is inserted with the printed side facing up.
- Wipe the disc with fibre cleaning cloth from the centre to the edge in a straight line.
- This disc may be defective. Play another disc.
- Ensure that the CD is a finalised CD/CD-R/CD-RW.
- Ensure that the laser lens is clean.
- Ensure that the CD is not encoded with copyright protection technologies.

### The CD skips tracks

- Ensure that the CD is not damaged or dirty.
- Ensure that program/shuffle mode is deactivated.

# 8 Notice

Any changes or modifications made to this device that are not expressly approved by Philips Consumer Lifestyle may void the user's authority to operate the equipment. Your product is designed and manufactured with high quality materials and components, which can be recycled and reused. Never dispose of your product with other household waste. Please inform yourself about the local rules on the separate collection of electrical and electronic products and batteries. The correct disposal of these products helps prevent potentially negative consequences on the environment and human health.

### Environmental information

All unnecessary packaging has been omitted. We have tried to make the packaging easy to separate into three materials: cardboard (box), polystyrene foam (buffer) and polyethylene (bags, protective foam sheet.) Your system consists of materials which can be recycled and reused if disassembled by a specialized company. Please observe the local regulations regarding the disposal of packaging materials, exhausted batteries and old equipment.



The making of unauthorized copies of copy-protected material, including computer programs, files, broadcasts and sound recordings, may be an infringement of copyrights and constitute a criminal offence. This equipment should not be used for such purposes. Recording and playback of material might require consent. See Copyright Act 1956 and The Performer's Protection Acts 1958 to 1972.

This apparatus includes these labels:



Class II equipment symbol



This symbol indicates that the apparatus has a double insulation system.

### Note

- The type plate is located on the bottom of the device.



Specifications are subject to change without notice  
© 2012 Koninklijke Philips Electronics N.V.  
All rights reserved.

ARG1837\_77\_UM\_V1.0

