

Register your product and get support at
www.philips.com/welcome



Thank you for choosing Philips.

Need help fast?

Read your Quick Start Guide and/or User Manual first for quick tips that make using your Philips product more enjoyable.

If you have read your instructions and still need assistance, you may access our online help at

www.philips.com/welcome



Philips vous remercie de votre confiance.

Besoin d'une aide rapide?

Le Guide rapide de début et Manuel de l'utilisateur regorgent d'astuces destinées à simplifier l'utilisation de votre produit Philips.

Toutefois, si vous ne parvenez pas à résoudre votre problème, vous pouvez accéder à notre aide en ligne à l'adresse

www.philips.com/welcome



Gracias por escoger Philips

Necesita ayuda inmediata?

Lea primero la Guía rápida del comienzo o el Manual del usuario, en donde encontrará consejos que le ayudarán a disfrutar plenamente de su producto Philips.

Si después de leerlo aún necesita ayuda, consulte nuestro servicio de asistencia en línea en

www.philips.com/welcome



EN	User manual	4
ES	Manual del usuario	20
FR	Mode d'emploi	36

English:

This digital apparatus does not exceed the Class B limits for radio noise emissions from digital apparatus as set out in the Radio Interference Regulations of the Canadian Department of Communications. This Class B digital apparatus complies with Canadian ICES-003.

Français :

Cet appareil numérique n'émet pas de bruits radioélectriques dépassant les limites applicables aux appareils numériques de Classe B prescrites dans le Règlement sur le Brouillage Radioélectrique édicté par le Ministère des Communications du Canada. Cet appareil numérique de la classe B est conforme à la norme NMB-003 du Canada.

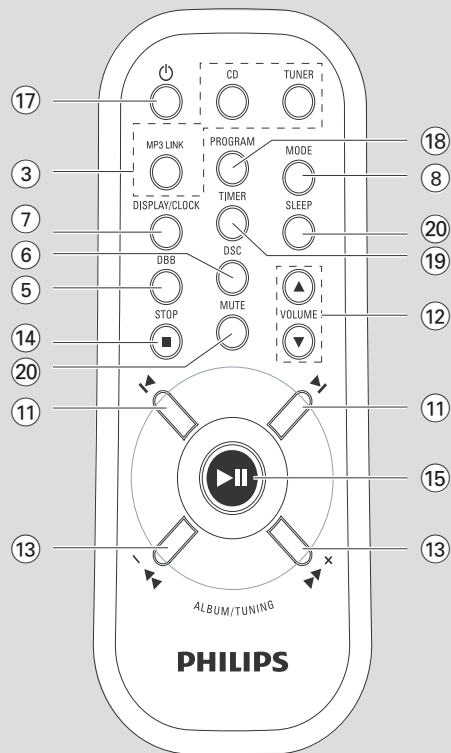

Front view

Top view

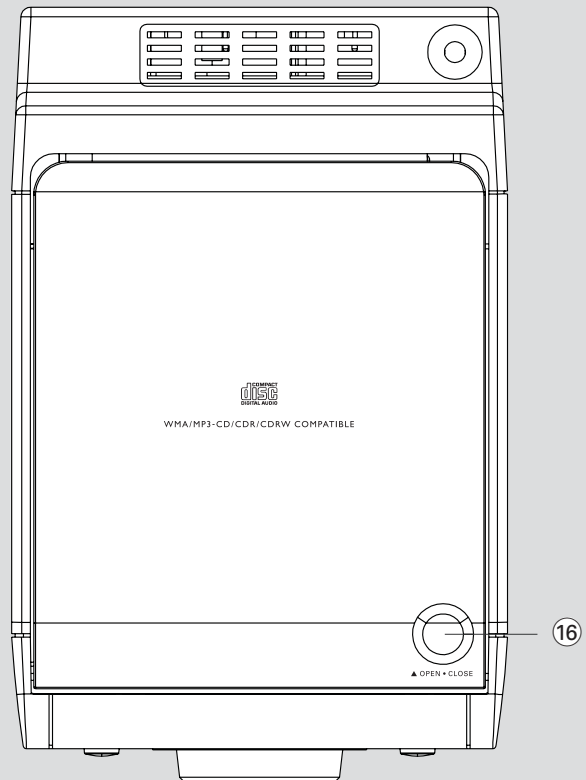
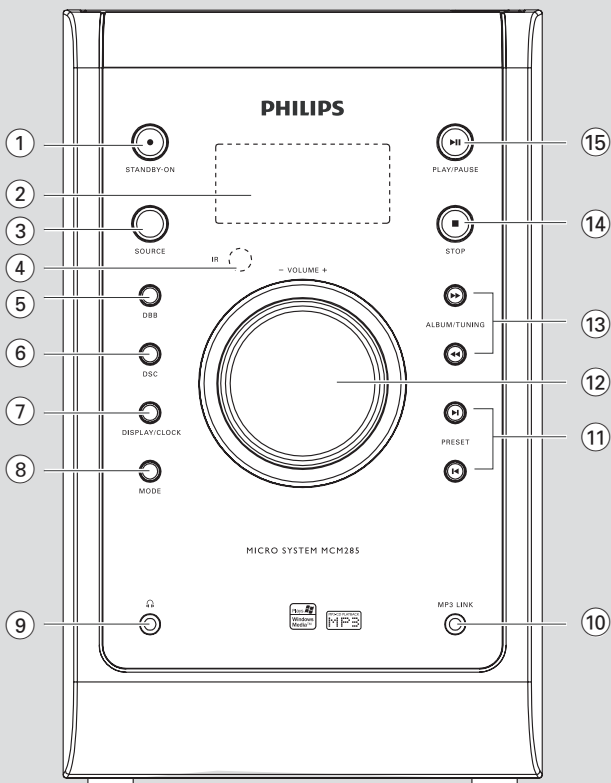

**Return your Product Registration Card or register online at
www.philips.com/welcome today to get the very most from your purchase.**

Registering your model with PHILIPS makes you eligible for all of the valuable benefits listed below, so don't miss out. Complete and return your Product Registration Card at once, **or register online at www.philips.com/welcome** to ensure:

*Proof of Purchase

Returning the enclosed card guarantees that your date of purchase will be on file, so no additional paperwork will be required from you to obtain warranty service.

*Product Safety Notification

By registering your product, you'll receive notification - directly from the manufacturer - in the rare case of a product recall or safety defect.

*Additional Benefits

Registering your product guarantees that you'll receive all of the privileges to which you're entitled, including special money-saving offers.

PHILIPS

Congratulations on your purchase, and welcome to the "family!"

Dear PHILIPS product owner:

Thank you for your confidence in PHILIPS. You've selected one of the best-built, best-backed products available today. We'll do everything in our power to keep you happy with your purchase for many years to come.

As a member of the PHILIPS "family," you're entitled to protection by one of the most comprehensive warranties and outstanding service networks in the industry. What's more, your purchase guarantees you'll receive all the information and special offers for which you qualify, plus easy access to accessories from our convenient home shopping network.

Most importantly, you can count on our uncompromising commitment to your total satisfaction.

All of this is our way of saying welcome - and thanks for investing in a PHILIPS product.

P.S. To get the most from your PHILIPS purchase, be sure to complete and return your Product Registration Card at once, or register online at:

www.philips.com/welcome

Know these
safety symbols



 This "bolt of lightning" indicates uninsulated material within your unit may cause an electrical shock. For the safety of everyone in your household, please do not remove product covering.

 The "exclamation point" calls attention to features for which you should read the enclosed literature closely to prevent operating and maintenance problems.

WARNING: To reduce the risk of fire or electric shock, this apparatus should not be exposed to rain or moisture and objects filled with liquids, such as vases, should not be placed on this apparatus.

CAUTION: To prevent electric shock, match wide blade of plug to wide slot, fully insert.

ATTENTION: Pour éviter les choc électriques, introduire la lame la plus large de la fiche dans la borne correspondante de la prise et pousser jusqu'au fond.

For Customer Use

Enter below the Serial No. which is located on the rear of the cabinet. Retain this information for future reference.

Model No. _____

Serial No. _____

PHILIPS

Visit our World Wide Web Site at <http://www.philips.com/welcome>

PHILIPS LIMITED WARRANTY

ONE (1) YEAR

English

WARRANTY COVERAGE:

PHILIPS warranty obligation is limited to the terms set forth below.

WHO IS COVERED:

Philips warrants the product to the original purchaser or the person receiving the product as a gift against defects in materials and workmanship as based on the date of original purchase ("Warranty Period") from an Authorized Dealer. The original sales receipt showing the product name and the purchase date from an authorized retailer is considered such proof.

WHAT IS COVERED:

The Philips warranty covers new products if a defect in material or workmanship occurs and a valid claim is received by Philips within the Warranty Period. At its option, Philips will either (1) repair the product at no charge, using new or refurbished replacement parts, or (2) exchange the product with a product that is new or which has been manufactured from new, or serviceable used parts and is at least functionally equivalent or most comparable to the original product in Philips current inventory, or (3) refund the original purchase price of the product.

Philips warrants replacement products or parts provided under this warranty against defects in materials and workmanship from the date of the replacement or repair for ninety (90) days or for the remaining portion of the original product's warranty, whichever provides longer coverage for you. When a product or part is exchanged, any replacement item becomes your property and the replaced item becomes Philips' property. When a refund is given, your product becomes Philips' property.

Note: Any product sold and identified as refurbished or renewed carries a ninety (90) day limited warranty.

Replacement product can only be sent if all warranty requirements are met. Failure to follow all requirements can result in delay.

WHAT IS NOT COVERED - EXCLUSIONS AND LIMITATIONS:

This Limited Warranty applies only to the new products manufactured by or for Philips that can be identified by the trademark, trade name, or logo affixed to it. This Limited Warranty does not apply to any non-Philips hardware product or any software, even if packaged or sold with the product. Non-Philips manufacturers, suppliers, or publishers may provide a separate warranty for their own products packaged with the bundled product.

Philips is not liable for any damage to or loss of any programs, data, or other information stored on any media contained within the product, or any non-Philips product or part not covered by this warranty. Recovery or reinstallation of programs, data or other information is not covered under this Limited Warranty.

This warranty does not apply (a) to damage caused by accident, abuse, misuse, neglect, misapplication, or non-Philips product, (b) to damage caused by service performed by anyone other than Philips or Philips Authorized Service Location, (c) to a product or a part that has been modified without the written permission of

Philips, or (d) if any Philips serial number has been removed or defaced, or (e) product, accessories or consumables sold "AS IS" without warranty of any kind by including refurbished Philips product sold "AS IS" by some retailers.

This Limited Warranty does not cover:

- Shipping charges to return defective product to Philips.
- Labor charges for installation or setup of the product, adjustment of customer controls on the product, and installation or repair of antenna/signal source systems outside of the product.
- Product repair and/or part replacement because of improper installation or maintenance, connections to improper voltage supply, power line surge, lightning damage, retained images or screen markings resulting from viewing fixed stationary content for extended periods, product cosmetic appearance items due to normal wear and tear, unauthorized repair or other cause not within the control of Philips.
- Damage or claims for products not being available for use, or for lost data or lost software.
- Damage from mishandled shipments or transit accidents when returning product to Philips.
- A product that requires modification or adaptation to enable it to operate in any country other than the country for which it was designed, manufactured, approved and/or authorized, or repair of products damaged by these modifications.
- A product used for commercial or institutional purposes (including but not limited to rental purposes).
- Product lost in shipment and no signature verification receipt can be provided.
- Failure to operate per Owner's Manual.

TO OBTAIN ASSISTANCE IN THE U.S.A., PUERTO RICO, OR U.S. VIRGIN ISLANDS...

Contact Philips Customer Care Center at:
1 866 771 4018

TO OBTAIN ASSISTANCE IN CANADA...

1 800 661 6162 (French Speaking)
1 866 771 4018 (English or Spanish Speaking)

REPAIR OR REPLACEMENT AS PROVIDED UNDER THIS WARRANTY IS THE EXCLUSIVE REMEDY FOR THE CONSUMER. PHILIPS SHALL NOT BE LIABLE FOR ANY INCIDENTAL OR CONSEQUENTIAL DAMAGES FOR BREACH OF ANY EXPRESS OR IMPLIED WARRANTY ON THIS PRODUCT, EXCEPT TO THE EXTENT PROHIBITED BY APPLICABLE LAW, ANY IMPLIED WARRANTY OF MERCHANTABILITY OR FITNESS FOR A PARTICULAR PURPOSE ON THIS PRODUCT IS LIMITED IN DURATION TO THE DURATION OF THIS WARRANTY.

Some states do not allow the exclusions or limitation of incidental or consequential damages, or allow limitations on how long an implied warranty lasts, so the above limitations or exclusions may not apply to you.

This warranty gives you specific legal rights. You may have other rights which vary from state/province to state/province.

P&F USA, Inc. P.O. Box 672768, Marietta, GA. 30006

3121 233 48802

IMPORTANT SAFETY INSTRUCTIONS

1. **Read these instructions.**
2. **Keep these instructions.**
3. **Heed all warnings.**
4. **Follow all instructions.**
5. **Do not use this apparatus near water.**
6. **Clean only with dry cloth.**
7. **Do not block any ventilation openings. Install in accordance with the manufacturer's instructions.**
8. **Do not install near any heat sources** such as radiators, heat registers, stoves, or other apparatus (including amplifiers) that produce heat.

9. **Do not defeat the safety**

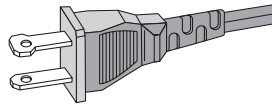

AC Polarized Plug

purpose of the polarized or

grounding-type plug. A polarized plug has two blades with one wider than the other. A grounding type plug has two blades and a third grounding prong. The wide blade or the third prong are provided for your safety. If the provided plug does not fit into your outlet, consult an electrician for replacement of the obsolete outlet.

10. **Protect the power cord** from being walked on or pinched, particularly at plugs, convenience receptacles, and the point where they exit from the apparatus.
11. **Only use attachments/accessories** specified by the manufacturer.

12.  **Use only with the cart,** stand, tripod, bracket, or table specified by the manufacturer or sold with the apparatus. When a cart is used, use caution when moving the cart /apparatus combination to avoid injury from tip-over.

13. **Unplug this apparatus** during lightning storms or when unused for long periods of time.
14. **Refer all servicing** to qualified service personnel. Servicing is required when the apparatus has been damaged in any way, such as power-supply cord or plug is damaged, liquid has been spilled or objects have fallen into the apparatus, the apparatus has been exposed to rain or moisture, does not operate normally, or has been dropped.
15. **Where the MAINS plug or an appliance coupler is used as the disconnet device, the disconnet device shall remain readily operable.**

16. **Battery usage CAUTION** – To prevent battery leakage which may result in bodily injury, property damage, or damage to the unit:

Install **all** batteries correctly, **+** and **-** as marked on the unit.

Do not mix batteries (**old** and **new** or **carbon** and **alkaline**, etc.).

Remove batteries when the unit is not used for a long time.

17. **Apparatus shall not be exposed to dripping or splashing.**
18. **Do not place any sources of danger on the apparatus** (e.g. liquid filled objects, lighted candles).
19. This product may contain lead and mercury. Disposal of these materials may be regulated due to environment considerations.
For disposal or recycling information, please contact your local authorities or the Electronic Industries Alliance: www.eiae.org.

EL 6475-S004: 03/12

Class II equipment symbol



This symbol indicates that the unit has a double insulation system

General Information

Supplied accessories.....	8
Environmental information	8
Safety information.....	8

Preparation

Rear connections.....	9
Optional connection	10
Inserting batteries into the remote control ..	10

Controls

Controls on the system and remote control.....	11
--	----

Basic Functions

Switching the system on.....	12
Power-saving automatic standby.....	12
Adjusting volume and sound	12

CD/MP3/WMA Operation

Playing a disc	13
Selecting a different track	13
Finding a passage within a track	13
Playing an MP3/WMA disc.....	13
Discs for playback.....	14
Different play modes: Shuffle and Repeat.....	14
Programming track numbers.....	14
Erasing the programme	14

Radio Reception

Tuning to radio stations.....	15
Programming radio stations	15
Automatic programming	
Manual programming	
Tuning to preset radio stations.....	15

External Sources

Connecting external equipment	16
-------------------------------------	----

Clock/Timer

Setting the clock.....	16
Setting the sleep timer	16-17
Setting the timer	17

Specifications

Maintenance

Troubleshooting

CAUTION

Use of controls or adjustments or performance of procedures other than herein may result in hazardous radiation exposure or other unsafe operation.

Congratulations on your purchase and welcome to Philips!

To fully benefit from the support that Philips offers, register your product at www.philips.com/welcome.

Supplied accessories

- 2 speaker boxes
- remote control
- MP3 link cable

Environmental information

All unnecessary packaging has been omitted. We have tried to make the packaging easy to separate into three materials: cardboard (box), polystyrene foam (buffer) and polyethylene (bags, protective foam sheet).

Your system consists of materials which can be recycled and reused if disassembled by a specialized company. Please observe the local regulations regarding the disposal of packaging materials, exhausted batteries and old equipment.

Notice of compliance

The set complies with the FCC-Rules, Part 15 and with RSS-210 of Industry Canada. Operation is subject to the following two conditions:

1. This device may not cause harmful interference, and
2. This device must accept any interference received, including interference that may cause undesired operation.

The making of unauthorized copies of copy-protected material, including computer programmes, files, broadcasts and sound recordings, may be an infringement of copyrights and constitute a criminal offence. This equipment should not be used for such purposes.

Safety information

- Before operating the system, check that the operating voltage indicated on the typeplate (or the voltage indication beside the voltage selector) of your system is identical with the voltage of your local power supply. If not, please consult your dealer.
- Place the system on a flat, hard and stable surface.
- Place the system in a location with adequate ventilation to prevent internal heat build-up in your system. Allow at least 10 cm (4 inches) clearance from the rear and the top of the unit and 5 cm (2 inches) from each side.
- The ventilation should not be impeded by covering the ventilation openings with items, such as newspapers, table-cloths, curtains, etc.
- Do not expose the system, batteries or discs to excessive moisture, rain, sand or heat sources caused by heating equipment or direct sunlight.
- No naked flame sources, such as lighted candles, should be placed on the apparatus.
- No objects filled with liquids, such as vases, shall be placed on the apparatus.
- The apparatus shall not be exposed to dripping or splashing.
- Install this unit near the AC outlet and where the AC power plug can be reached easily.
- If the system is brought directly from a cold to a warm location, or is placed in a very damp room, moisture may condense on the lens of the disc unit inside the system. Should this occur, the CD player would not operate normally. Leave the power on for about one hour with no disc in the system until normal playback is possible.
- The mechanical parts of the set contain self-lubricating bearings and must not be oiled or lubricated.
- **When the system is switched to Standby mode, it is still consuming some power. To disconnect the system from the power supply completely, remove the AC power plug from the wall socket.**



**Be responsible
Respect copyrights**

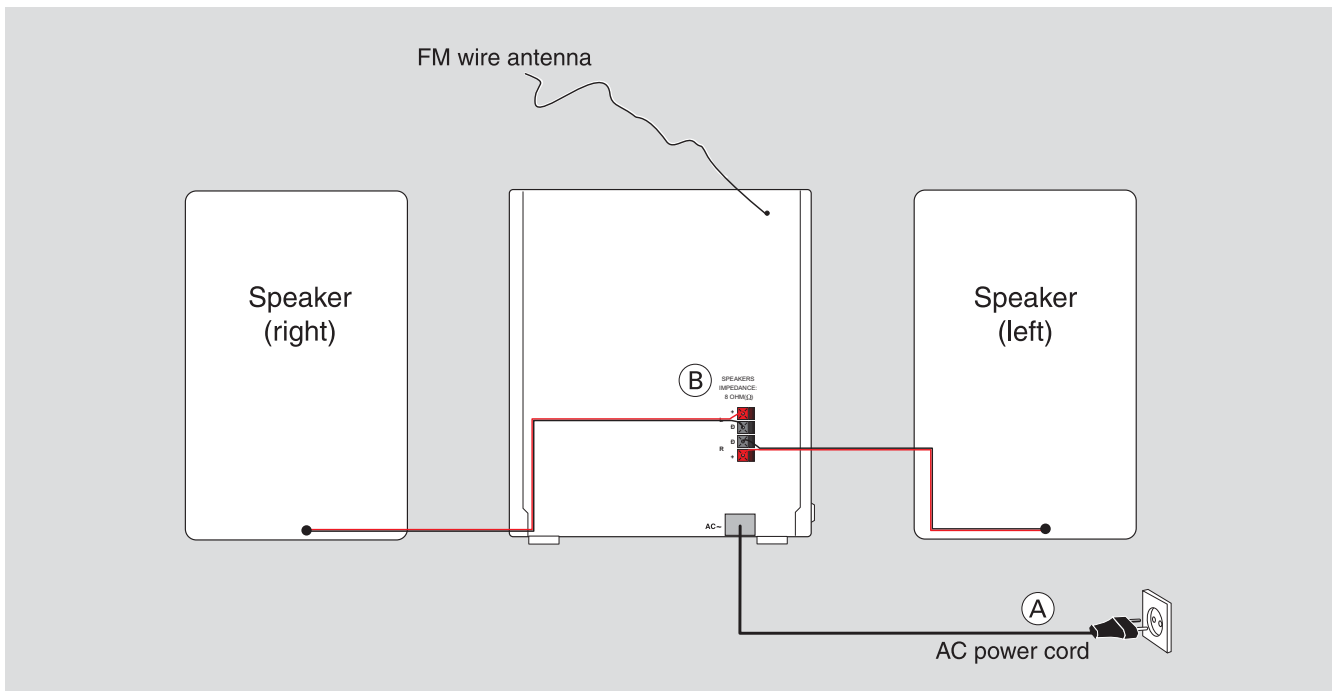

Rear connections

The type plate is located at the rear of the system.

(A) Power

– Before connecting the AC power cord to the wall outlet, ensure that all other connections have been made.

WARNING!

- **For optimal performance, use only the original power cable.**
- **Never make or change any connections with the power switched on.**

To avoid overheating of the system, a safety circuit has been built in. Therefore, your system may switch to Standby mode automatically under extreme conditions. If this happens, let the system cool down before reusing it (not available for all versions).

(B) Speakers Connection

Front Speakers

Connect the speaker wires to the SPEAKERS terminals, right speaker to "R" and left speaker to "L", red wires to "+" and black wires to "-".

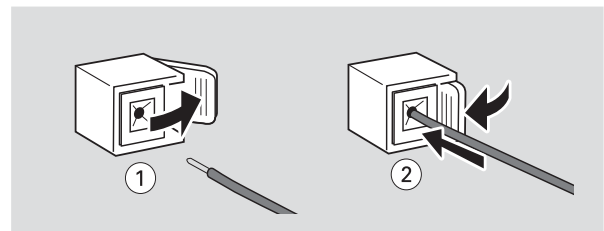

- Fully insert the stripped portion of the speaker wire into the terminal as shown.

Notes:

- For optimal sound performance, use the supplied speakers.
- Do not connect more than one speaker to any one pair of + / - speaker terminals.
- Do not connect speakers with an impedance lower than the speakers supplied. Please refer to the SPECIFICATIONS section of this manual.

Optional connection

The optional equipment and connecting cords are not supplied. Refer to the operating instructions of the connected equipment for details.

Connecting a non-USB device

Use a cinch cable to connect **MP3 LINK** to the audio out terminals of an external equipment (TV,VCR, Laser Disc player, DVD player or CD Recorder).

Inserting batteries into the remote control

Insert 2 batteries type AAA into the remote control with the correct polarity as indicated by the "+" and "-" symbols inside the battery compartment.

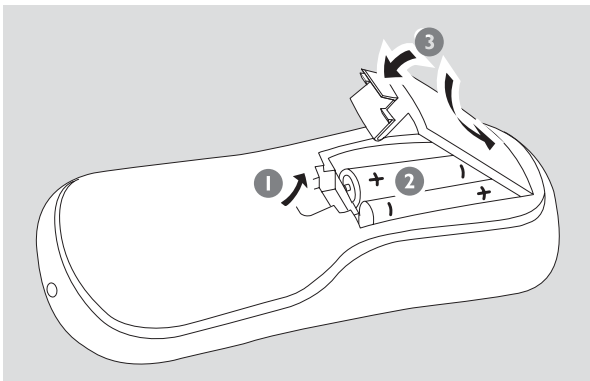

CAUTION!

- **Do not mix old and new batteries.**
- **Do not mix alkaline, standard (carbon-zinc), or rechargeable (ni-cad, ni-mh, etc) batteries.**
- **Batteries contain chemical substances, so they should be disposed of properly.**
- **Remove batteries if they are exhausted or will not be used for a long time.**
- **Perchlorate Material - special handling may apply. See www.dtsc.ca.gov/hazardouswaste/perchlorate.**

Controls on the system and remote control

- ① **STANDBY ON**
– switches the system on or to standby mode.
- ② **LCD Display**
– shows the status of the system.
- ③ **Source (CD/TUNER/MP3 LINK)**
– selects the respective sound source for CD/TUNER/MP3 LINK.
- ④ **iR SENSOR**
– infrared sensor for remote control.
- ⑤ **DBB (Dynamic Bass Boost)**
– turns on/off the dynamic bass enhancement.
- ⑥ **DSC (Digital Sound Control)**
– selects sound characteristics: CLASSIC, JAZZ, POP or ROCK.
- ⑦ **DISPLAY/CLOCK**
– to set or view the clock.
- ⑧ **MODE**
– selects different play modes: e.g. REPEAT or SHUFFLE (random order)
- ⑨ 
– Plugs in a headphone.
- ⑩ **MP3 LINK**
– 3.5mm audio input jack.
- ⑪ **PRESET +/- ◀/▶**
– skips to the beginning of a current track/previous/next track.

– sets the hours and minutes for the clock and timer.

– selects a preset radio station.
- ⑫ **VOLUME +/-**
– adjusts the volume level.
- ⑬ **ALBUM/TUNING ◀◀ / ▶▶**
– selects an album.

– tunes to a radio station.
– (press and hold) fast searches back and forward within a track/disc.
- ⑭ **STOP ■**
– stops CD playback or erases a CD program.
- ⑮ **▶||**
– starts or pauses CD playback.
- ⑯ **OPEN/CLOSE**
– open/close the CD door.
- ⑰ 
– switches the system on or to standby mode.
- ⑱ **PROGRAM**
– (for CD) programs CD tracks and reviews the program.

– (for TUNER) programs preset radio stations.
- ⑲ **TIMER**
– activates/deactivates the timer.
- ⑳ **SLEEP**
– activates/deactivates or selects the sleep time.

– views the remaining sleep time.
- ㉑ **MUTE**
– switches playback sound off and on.

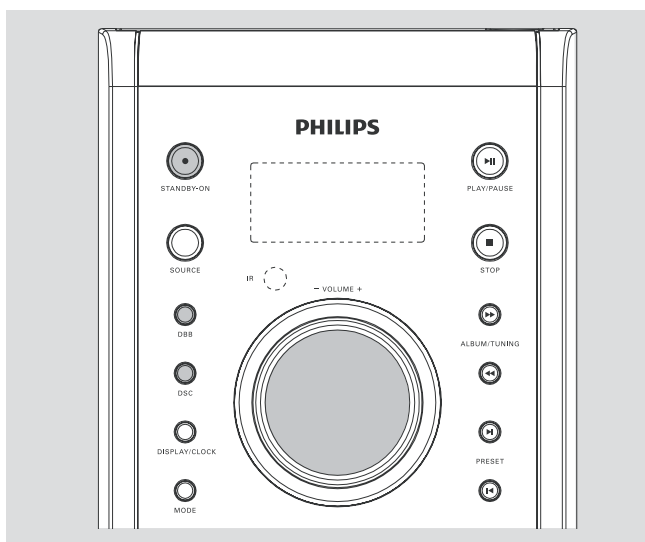

IMPORTANT:

Before you operate the system, complete the preparation procedures.

Switching the system on

- Press **STANDBY-ON** on the main set.
→ The system will switch to the last selected source.
- Press **CD**, **TUNER**, or **MP3 LINK** on the remote control.
→ The system will switch to the selected source.

To switch the system to standby mode

- Press **STANDBY-ON** (⏻ on the remote control).
→ The volume level (up to a maximum volume level of 15), interactive sound settings, last selected source and tuner presets will be retained in the player's memory.

Power-saving automatic standby

The power-saving feature automatically switches to standby 15 minutes after CD playback has ended and no control is operated.

Adjusting volume and sound

- 1 Adjust the **VOLUME** control knob or press **VOLUME** ▲/▼ on the remote control to increase or decrease volume.
→ Display shows the volume level **100** and a number from 0-40.

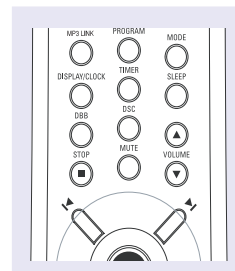

- 2 Press **DBB** to switch bass enhancement on or off.
→ Display shows: **DBB** if the DBB is activated.
 - 3 Press **DSC** on the remote control repeatedly to select the desired sound effect: CLASSIC, JAZZ, POP, or ROCK.
→ The selected DSC is shown.
 - 4 Press **MUTE** on the remote control to stop sound playback instantly.
→ Playback will continue without sound and the display shows **MUTE**.
- To start sound playback you can:
 - press **MUTE** again;
 - adjust the volume controls.

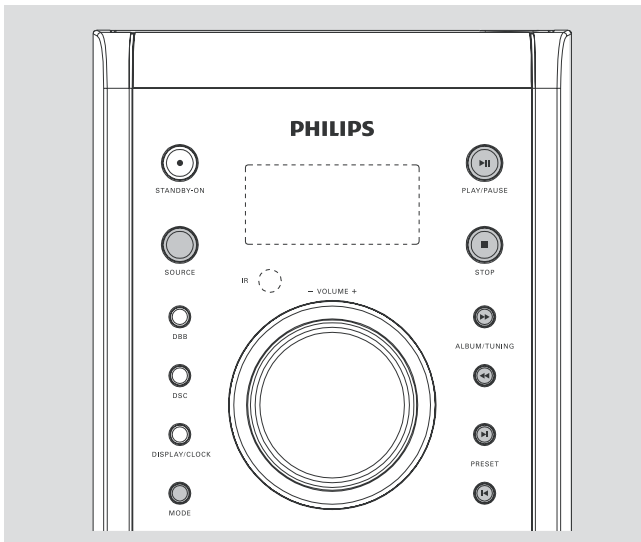

IMPORTANT:
The lens of the CD player should never be touched.

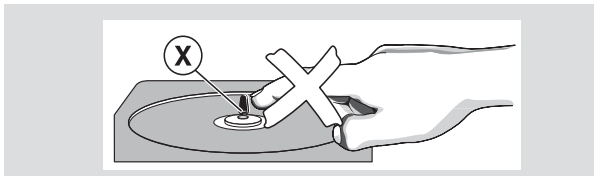

Playing a disc

This CD player plays Audio Discs including CD-Recordables, CD-Rewritables and MP3 CD.

- CD-ROM, CD-I, CDV, VCD, DVD or computer CDs, however, are not possible.
- 1 Press **SOURCE** once or more or **CD** on the remote control to select **CD**.
 - 2 Press **OPEN/CLOSE** on the system to open the CD compartment.
→ *OPEN* is displayed when you open the CD compartment.
 - 3 Insert a disc with the printed side facing up and press **OPEN/CLOSE** to close the CD door.
→ Play starts automatically.
 - 4 To pause, press **▶II**. Press **▶II** again to resume play.

- 5 To stop disc playback, press **STOP** ■.

Note: CD playback will also stop when;

- the CD door is opened.
- the disc has reached the end.
- you select another source: **TUNER** or **MP3 LINK**.
- you select standby.

Selecting a different track

- Press **PRESET +/-** ◀/▶ (◀/▶ on the remote) once or repeatedly until the desired track number appears in the display.

Finding a passage within a track

- 1 Press and hold down **ALBUM/TUNING** ◀◀ / ▶▶ (◀◀/▶▶ on the remote).
→ The disc is played at high speed and low volume.
- 2 When you find the passage you want, release **ALBUM/TUNING** ◀◀ / ▶▶ (◀◀/▶▶ on the remote).
→ Normal playback continues.

Playing an MP3/WMA disc

- 1 Load an MP3/WMA disc.
→ The disc reading time may exceed 10 seconds due to the large number of songs compiled into one disc.
→ Play starts automatically.
- To pause, press **▶II**. Press **▶II** again to resume play.
- To select an album, press **ALBUM/TUNING** ◀◀ / ▶▶.
- To skip to a track, press **PRESET +/-** ◀/▶ (◀/▶ on the remote).

Discs for playback

This system can playback all digital audio CD, finalised digital audio CD-Recordable (CDR) discs and finalised digital audio CD-Rewritable (CDRW) discs.

MP3-CDs (CD-ROMs with MP3 tracks)



Supported MP3 disc formats:

- ISO9660, Joliet, UDF 1.5
- Maximum title number: 511 (depending on filename length)
- Maximum album number: 52
- Supported sampling frequencies: 32 kHz, 44.1 kHz, 48 kHz
- Supported Bit-rates: 32~256 (kbps), variable bitrates

Different play modes: SHUFFLE and REPEAT

You can select and change the various play modes before or during playback.

REPEATplays the current track continuously

REPEAT ALL.....repeats the entire disc/ programme

SHUFtracks of the entire disc are played in random order

SHUF REPEAT ALL

.....repeats the disc continuously in random order

- 1 To select your play mode, press **MODE** before or during playback until the display shows the desired function.
 - 2 Press **▶||** to start playback if in the STOP position.
 - 3 To return to normal playback, press **MODE** until the various SHUFFLE/ REPEAT modes are no longer displayed.
- You can also press **STOP ■** to cancel your play mode.

Programming track numbers

Programme in the STOP position to select and store your disc tracks in the desired sequence. If you like, store any track more than once. Up to 20 tracks can be stored in the memory.

- 1 In the STOP position, press **PROGRAM** on the remote control to enter the programming mode.
- 2 Use **PRESET +/-** **◀/▶** (**◀/▶** on the remote) to select your desired track number.
- For MP3/WMA disc, press **ALBUM/TUNING** **◀◀ / ▶▶** (**◀◀ / ▶▶** on the remote) to select the desired album and title for programming.
→ The selected track number and **PROG** flash on the display panel.
- 3 Press **PROGRAM** on the remote control to confirm the track number to be stored.
- 4 Repeat steps **2-3** to select and store all desired tracks.
- 5 To start playback of your disc programme, press **▶||**.

Note:

- If you wish, you can add further tracks to your current program. Make sure you are in the STOP position, and that you have not exceeded 20 tracks.

Erasing the programme

You can erase the programme by:

- pressing **STOP ■** once in the STOP mode;
- pressing **STOP ■** twice during playback;
- opening the CD compartment;
- selecting another sound source
→ **PROG** disappears from the display.

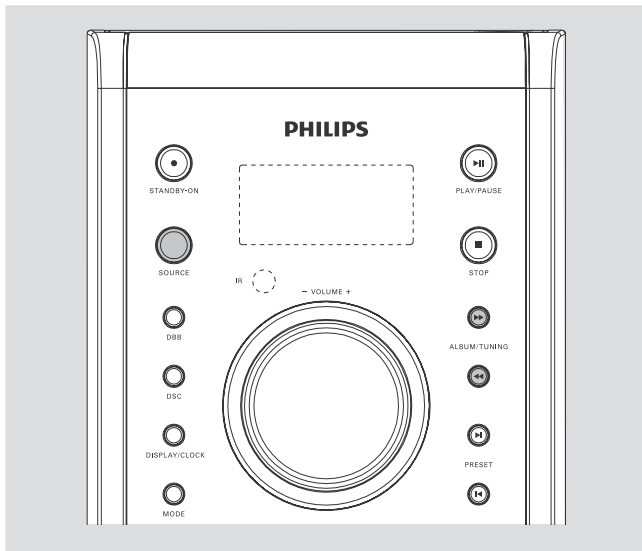

Tuning to radio stations

- 1 Press **SOURCE** or **TUNER** once or more to select the desired waveband : FM or AM (MW).
 - 2 Press and hold **ALBUM/TUNING** ◀▶ until the frequency indication starts to change, then release.
 - The display will show "SEARCH" until a radio station with sufficient signal strength is found.
 - If the FM station is received in stereo, ∞ is shown..
 - 3 Repeat step 2 if necessary until you find the desired radio station.
- To tune to a weak station, press **ALBUM/TUNING** ◀▶ briefly and repeatedly until optimal reception found.

Note:

– The system is equipped with a fixed FM antenna and a built-in AM antenna. For optimal FM reception, *fully extend and adjust the position of the FM antenna until the strongest signal is found.*

Programming radio stations

You can store up to 40 radio stations (FM:20, AM: 20) in the memory.

Automatic programming

- 1 In tuner mode, press and hold **PROGRAM** for 2 seconds to activate the automatic program mode.
 - **[AUTO]** (auto) is displayed and begins to blink.
 - All available radio stations with sufficient signal strength will be stored automatically.

To stop automatic programming

- Press **STOP** ■ .

Note:

– *If no preset number is selected, automatic preset will begin from preset (1) and all your former presets will be overridden.*

Manual programming

- 1 Tune to a radio station (refer to "Tuning to radio stations").
- 2 Press **PROGRAM**.
 - **PROG** begins to blink.

To store the radio station to another preset number

- Press **PRESET +/-** ◀/▶ to select the desired preset number.
- 3 Press **PROGRAM** again to store the radio station.
 - **PROG** disappears.
 - 4 Repeat **steps 1–3** to store other radio stations.

To exit manual programming

- Press **STOP** ■ .

Tuning to preset radio stations

- Press **PRESET +/-** ◀/▶ until the desired preset station is displayed.

External Sources

Connecting external equipment

- 1 Connect the audio out terminal of the portable device (i.e. iPod or MP3 player) to the **MP3 LINK** terminal of your system.
- 2 Press **SOURCE** once or more to select **MP3 LINK**.
→ "MP3 LINK" is displayed.

Note:

- All the sound control features (DSC or DBB, for example) are available for selection.
- Refer to the operating instructions for the connected equipment for details.

Clock/Timer

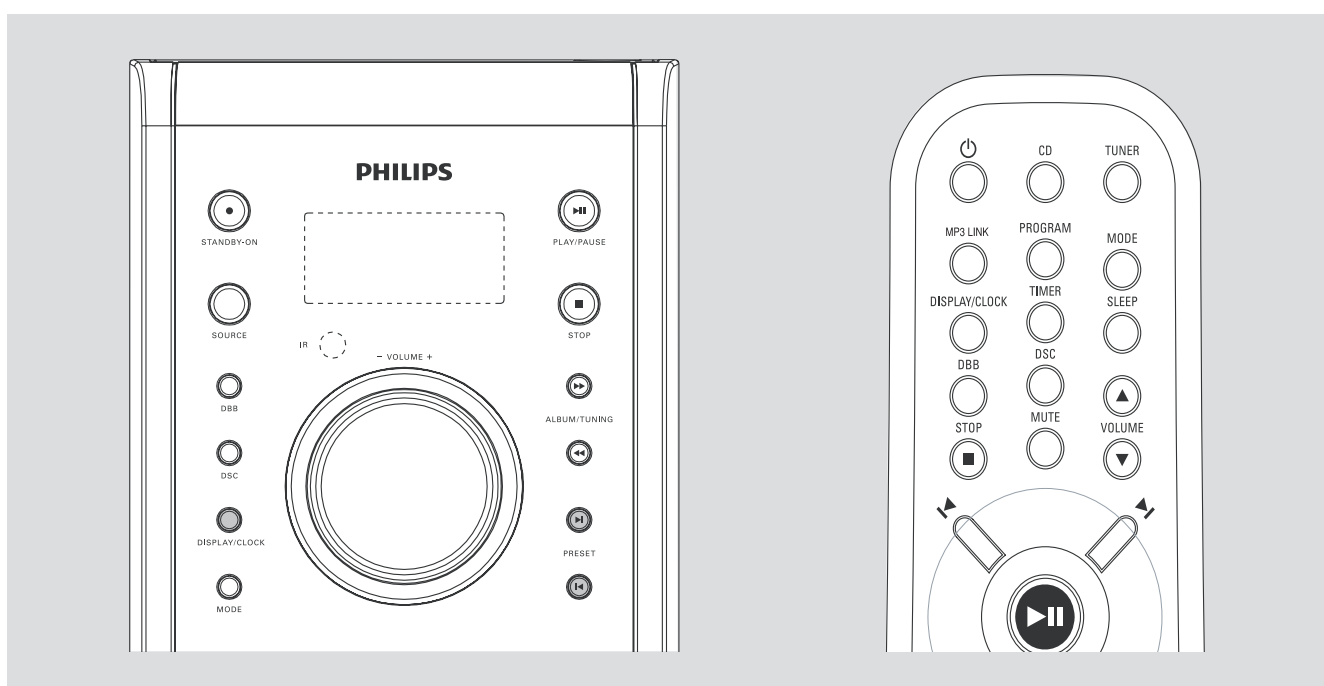

Setting the clock

- 1 In standby mode, press and hold **DISPLAY/CLOCK**.
→ The clock digits for the hours flash.
- 2 Press **PRESET +/-** (◀/▶) (◀/▶ on the remote) to set the hours.
- 3 Press **DISPLAY/CLOCK**.
→ The clock digits for the minutes flash.
- 4 Press **PRESET +/-** (◀/▶) (◀/▶ on the remote) to set the minutes.
- 5 Press **DISPLAY/CLOCK** to confirm the time.

Note:

- If the last selected source is MP3-LINK/AUX, you cannot use the remote control to set the clock in standby mode.

Setting the sleep timer

The sleep timer enables the system to switch off by itself after a set period of time.

- 1 In active mode, press **SLEEP** on the remote control repeatedly until the desired timer option appears.
→ Selections are as follows (time in minutes):
SLP OFF → SLP 120 → SLP 90 → SLP 60
→ SLP 45 → SLP 30 → SLP 15 → SLP OFF
→ Display shows „z“ if activated, and disappears if deactivated.
- 2 **To cancel the sleep function**, either press **SLEEP** on the remote control once or more until "SLP OFF" appears, or press **STANDBY-ON** (⏻ on the remote) to switch to standby mode.

To check the remaining length of time after sleep timer is activated









- Press **SLEEP** once.

Setting the timer

- The system can switch on to CD, TUNER, or MP3 LINK mode automatically at a preset time, serving as an alarm to wake you up.

IMPORTANT!

- **Before setting the timer, ensure that the clock is set correctly.**
- **The timer will always be switched on after it has been set.**
- **The timer will not start if a recording is in progress.**
- **The volume of the timer will increase gradually from the minimum level to the last tuned volume level (If the last tuned volume level is less than 15, it will increase gradually from the minimum level to 15).**

- 1 Press **TIMER** on the remote control.
→ The last timer setting is shown.
- 2 Press **TIMER** again for more than 2 seconds.
→ The clock digits for the hours flash.
- 3 Press **PRESET +/-**   (  on the remote) to set the hours.
- 4 Press **TIMER** again.
→ The clock digits for the minutes flash.
- 5 Press **PRESET +/-**   (  on the remote) to set the minutes.
- 6 Press **TIMER** to confirm the time.
→ The timer is now activated and display shows .

Note:

- *If the last selected source is MP3-LINK/AUX, you cannot use the remote control to set the timer.*

To deactivate the timer,

- Press **TIMER** in active or standby mode.
→  disappears if the timer is deactivated.

Notes:

- *When the preset time is reached, the last selected source will be played automatically.*
- *During timer setting, if no button is pressed within 10 seconds, the system will exit timer setting mode automatically.*
- *If remote control is used, timer/clock setting is available only in CD and TUNER modes.*

Specifications

AMPLIFIER

Total output power25 W (12.5 W per channel)
Signal-to-noise ratio≥ 62 dBA (IEC)
Frequency response..... 63 – 16000 Hz, ± 3 dB

CD PLAYER

Frequency range.....63 – 16000 Hz
Signal-to-noise ratio65 dBA

TUNER

FM wave range.....87.5 – 108 MHz
AM (MW) wave range.....530 – 1700 KHz

SPEAKERS

1-way Bass Reflex System
Impedance8 ohm
Speaker diameter.....4"
Dimensions (w x h x d).....14.6x23.6x18.5 (cm)
.....5.7x9.3x7.3 (inch)

GENERAL

AC Power.....120 V/60 Hz;
Dimensions (w x h x d).....14.6x23.6x23.9 (cm)
.....5.7x9.3x9.4 (inch)
Weight (with/without speakers).....6.42 / 2.5 kg
.....14.15 / 5.5 pounds

Specifications and external appearance are subject to change without notice.

Maintenance

Cleaning the Cabinet

- Use a soft cloth slightly moistened with a mild detergent solution. Do not use a solution containing alcohol, spirits, ammonia or abrasives.

Cleaning Discs

- When a disc becomes dirty, clean it with a cleaning cloth. Wipe the disc from the centre out.
- Do not use solvents such as benzene, thinner, commercially available cleaners, or antistatic spray intended for analogue records.

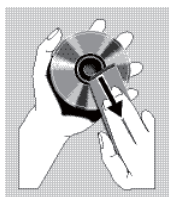

Cleaning the disc lens

- After prolonged use, dirt or dust may accumulate at the disc lens. To ensure good playback quality, clean the disc lens with Philips CD Lens Cleaner or any commercially available cleaner. Follow the instructions supplied with cleaner.

WARNING

Under no circumstances should you try to repair the system yourself, as this will invalidate the warranty. Do not open the system as there is a risk of electric shock.

If a fault occurs, first check the points listed below before taking the system for repair. If you are unable to remedy a problem by following these hints, consult your dealer or service centre.

Problem	Solution
CD OPERATION	
“No disc” is displayed.	<ul style="list-style-type: none"> – Insert a disc. – Check if the disc is inserted upside down. – Wait until the moisture condensation at the lens has cleared. – Replace or clean the disc, see “Maintenance”. – Use a finalised CD-RW, CD-R or MP3 CD.
RADIO RECEPTION	
Radio reception is poor.	<ul style="list-style-type: none"> – Increase the distance between the Micro HiFi System and your TV or VCR.
GENERAL	
The system does not react when buttons are pressed.	<ul style="list-style-type: none"> – Remove and reconnect the AC power plug and switch on the system again.
Sound cannot be heard or is of poor quality.	<ul style="list-style-type: none"> – Adjust the volume. – Check that the speakers are connected correctly. – Check if the stripped speaker wire is clamped.
The left and right sound outputs are reversed.	<ul style="list-style-type: none"> – Check the speaker connections and location.
The remote control does not function	<ul style="list-style-type: none"> – Reduce the distance between the remote control and the system. – Insert the batteries with their polarities (+/- signs) aligned as indicated. – Replace the batteries. – Point the remote control directly toward IR sensor on the front of the system.
The timer is not working.	<ul style="list-style-type: none"> – Set the clock correctly. – Press TIMER in standby mode to switch on the timer. – If a recording is in progress, stop the recording.
The Clock/Timer setting is erased.	<ul style="list-style-type: none"> – Power has been interrupted or the power cord has been disconnected. Reset the clock/timer.

Philips Consumer Lifestyle
A Division of Philips Electronics North America Corporation
P.O. BOX 671539, Marietta, GA. 30006-0026

Meet Philips at the Internet
<http://www.philips.com/welcome>

