

MP3-CD Mini Hi-Fi System

FWM139

User manual

Manual do usuário

Manual del usuario



PHILIPS

México



Es necesario que lea cuidadosamente su instructivo de manejo.

| | | |
|--------------------------------------------------------------------------------------------------------------------------------|---------------------------------------------------------------------------|--|
| | PRECAUCIÓN - ADVERTENCIA | |
| | No abrir, riesgo de choque eléctrico | |
| | ATENCIÓN | |
| | Verifique que el voltaje de alimentación sea el requerido para su aparato | |
| Para evitar el riesgo de choque eléctrico, no quite la tapa. En caso de requerir servicio, dirijase al personal calificado. | | |

Descripción: **Minisistema de Audio**
Modelo : **FWM139/55**
Alimentación: **110-127 / 220-240V~; 50-60 Hz**
Consumo: **42W**
Importador: **Philips Mexicana, S.A. de C.V.**
Domicilio: **Av. La Palma No.6**
Col. San Fernando La Herradura
Huixquilucan
Localidad y Tel: **Edo. de México C.P. 52784**
Tel.52 69 90 00
Exportador: **Philips Electronics HK, Ltd.**
País de Origen: **China**
N° de Serie: _____

**LEA CUIDADOSAMENTE ESTE INSTRUCTIVO
ANTES DE USAR SU APARATO.**

AVISO IMPORTANTE

Philips Mexicana, S.A. de C.V. no se hace responsable por daños o desperfectos causados por:

- *Maltrato, descuido o mal uso, presencia de insectos o roedores (cucarachas, ratones etc.).*
- *Cuando el aparato no haya sido operado de acuerdo con el instructivo del uso, fuera de los valores nominales y tolerancias de las tensiones (voltaje), frecuencia (ciclaje) de alimentación eléctrica y las características que deben reunir las instalaciones auxiliares.*
- *Por fenómenos naturales tales como: temblores, inundaciones, incendios, descargas eléctricas, rayos etc. o delitos causados por terceros (choques asaltos, riñas, etc.).*

CAUTION

Use of controls or adjustments or performance of procedures other than herein may result in hazardous radiation exposure or other unsafe operation.

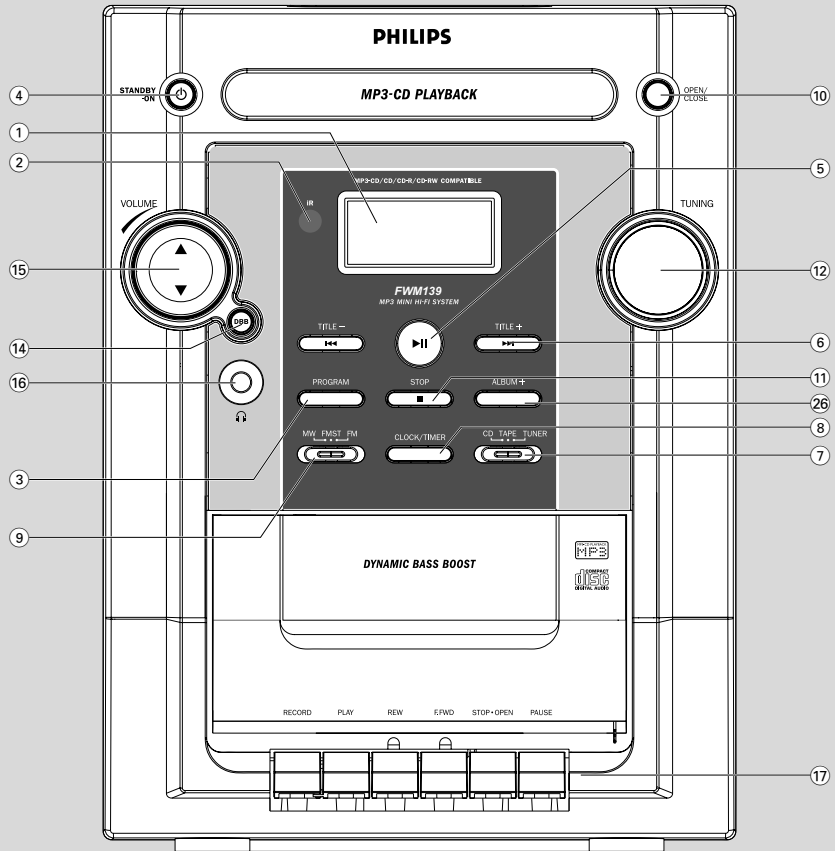
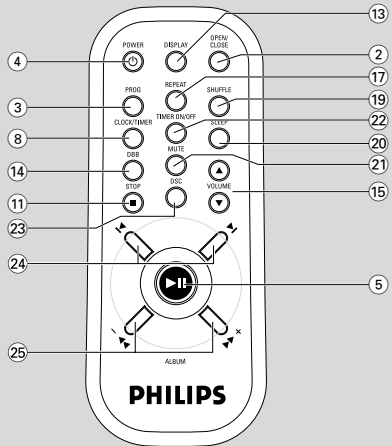

English 6

Español 21

Português 36

English

Español

Português

Contents

General Information

| | |
|---------------------------------|---|
| Environmental information | 7 |
| Supplied accessories | 7 |
| Safety information | 7 |

Preparation

| | |
|---------------------------------------------------|---|
| Rear connections | 8 |
| Inserting batteries into the remote control... .. | 9 |

Controls

| | |
|-------------------------------------------------|----|
| Controls on the system and remote control | 10 |
|-------------------------------------------------|----|

Basic Functions

| | |
|--------------------------------------|----|
| Switching the system on | 11 |
| Power-saving automatic standby | 11 |
| Adjusting volume and sound..... | 11 |

CD/MP3 Operation

| | |
|------------------------------------------------|-------|
| Playing a disc | 12 |
| Selecting a different track | 12 |
| Finding a passage within a track | 12 |
| Playing an MP3 disc | 12-13 |
| Different play modes: Shuffle and Repeat | 13 |
| Programming track numbers | 13 |
| Reviewing the programme | 13 |
| Erasing the programme | 13 |

Radio Reception

| | |
|--------------------------------|----|
| Tuning to radio stations | 14 |
|--------------------------------|----|

Tape Operation/Recording

| | |
|----------------------------------------|----|
| Tape playback | 15 |
| General information on recording | 15 |
| Synchro start CD recording | 15 |
| Recording from the radio | 16 |

| | |
|--------------------------|----|
| Maintenance | 16 |
|--------------------------|----|

Clock/Timer

| | |
|-----------------------------------------|----|
| Setting the clock | 17 |
| Setting the timer | 17 |
| Activating and deactivating TIMER | 17 |
| Activating and deactivating SLEEP | 18 |

| | |
|-----------------------------|----|
| Specifications | 18 |
|-----------------------------|----|

| | |
|------------------------------|-------|
| Troubleshooting | 19-20 |
|------------------------------|-------|

IMPORTANT!

PLEASE NOTE THAT THE VOLTAGE SELECTOR LOCATED AT THE REAR OF THIS SYSTEM IS PRESET AT 220V FROM THE FACTORY. FOR COUNTRIES THAT OPERATE AT 110V-127V, PLEASE ADJUST TO 110V-127V BEFORE YOU SWITCH ON THE SYSTEM.

Supplied accessories

- 2 speaker boxes
- remote control

Environmental Information

All unnecessary packaging has been omitted. We have tried to make the packaging easy to separate into three materials: cardboard (box), polystyrene foam (buffer) and polyethylene (bags, protective foam sheet).

Your system consists of materials which can be recycled and reused if disassembled by a specialized company. Please observe the local regulations regarding the disposal of packaging materials, exhausted batteries and old equipment.

The making of unauthorized copies of copy-protected material, including computer programmes, files, broadcasts and sound recordings, may be an infringement of copyrights and constitute a criminal offence. This equipment should not be used for such purposes.

Safety Information

- Before operating the system, check that the operating voltage indicated on the typeplate (or the voltage indication beside the voltage selector) of your system is identical with the voltage of your local power supply. If not, please consult your dealer.
- Place the system on a flat, hard and stable surface.
- Place the system in a location with adequate ventilation to prevent internal heat build-up in your system. Allow at least 10 cm (4 inches) clearance from the rear and the top of the unit and 5 cm (2 inches) from each side.
- The ventilation should not be impeded by covering the ventilation openings with items, such as newspapers, table-cloths, curtains, etc.
- Do not expose the system, batteries or discs to excessive moisture, rain, sand or heat sources caused by heating equipment or direct sunlight.
- No naked flame sources, such as lighted candles, should be placed on the apparatus.
- No objects filled with liquids, such as vases, shall be placed on the apparatus.
- The apparatus shall not be exposed to dripping or splashing.
- Install this unit near the AC outlet and where the AC power plug can be reached easily.
- If the system is brought directly from a cold to a warm location, or is placed in a very damp room, moisture may condense on the lens of the disc unit inside the system. Should this occur; the CD player would not operate normally. Leave the power on for about one hour with no disc in the system until normal playback is possible.
- The mechanical parts of the set contain self-lubricating bearings and must not be oiled or lubricated.
- **When the system is switched to Standby mode, it is still consuming some power. To disconnect the system from the power supply completely, remove the AC power plug from the wall socket.**



Be responsible
Respect copyrights

Preparations

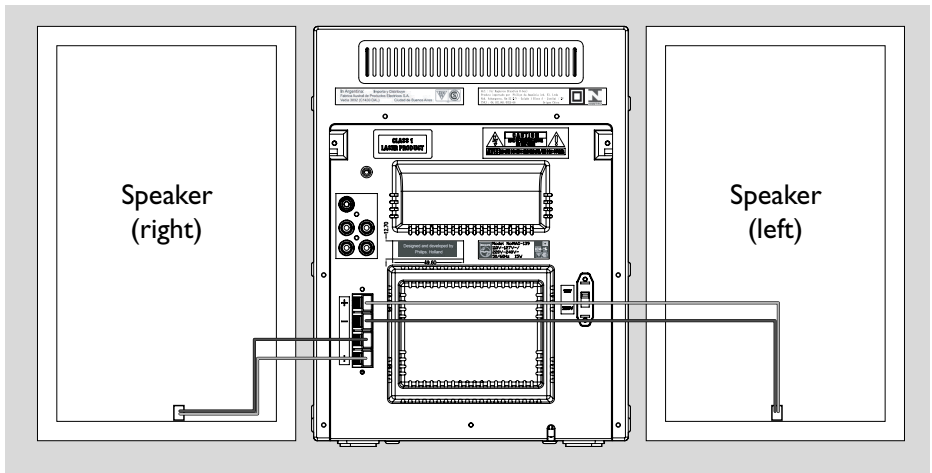

Rear connections

The type plate is located at the back of the system.

A Power

- Before connecting the AC power cord to the wall outlet, ensure that all other connections have been made.
- If your system is equipped with a Voltage Selector, set the VOLTAGE SELECTOR to the local power line voltage.

WARNING!

- **For optimal performance, use only the original power cable.**
- **Never make or change any connections with the power switched on.**

B Speakers Connection

Front Speakers

Connect the speaker wires to the SPEAKERS terminals, right speaker to "R" and left speaker to "L", coloured (marked) wire to "+" and black (unmarked) wire to "-".

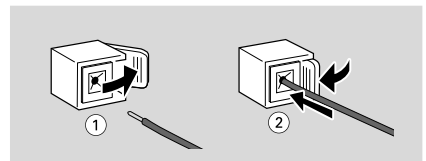

- Fully insert the stripped portion of the speaker wire into the terminal as shown.

Notes:

- For optimal sound performance, use the supplied speakers.
- Do not connect more than one speaker to any one pair of + / - speaker terminals.
- Do not connect speakers with an impedance lower than the speakers supplied. Please refer to the SPECIFICATIONS section of this manual.

Inserting batteries into the remote control



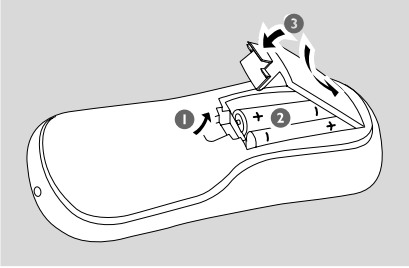





Insert two batteries type R03 or AAA into the remote control with the correct polarity as indicated by the "+" and "-" symbols inside the battery compartment.



CAUTION!

- *Remove batteries if they are exhausted or will not be used for a long time.*
- *Do not use old and new or different types of batteries in combination.*
- *Batteries contain chemical substances, so they should be disposed of properly.*

Controls on the system and remote control

- ① **LCD Display**
 - shows the status of the system.
- ② **iR SENSOR**
 - infrared sensor for remote control.
- ③ **PROGRAM (PROG)**
 - for CD programs tracks and reviews the program.
- ④ **STANDBY-ON  (POWER )**
 - switches the system to standby/on.
- ⑤ ****
 - for CD/MP3 starts or pauses CD playback.
- ⑥ **TITLE-/+  / **
 - for CD/MP3 skips to the beginning of a current track/previous/ next track (title).
(press and hold) fast searches back and forward within a track/ disc.
for clock/timer .. adjusts the hours and minutes for clock / timer functions.
- ⑦ **Source selector (CD/ TAPE/TUNER)**
 - selects the respective sound source for CD/ TAPE/ TUNER.
- ⑧ **CLOCK/TIMER**
 - sets the clock or timer function.
- ⑨ **Band selector (MW/FMST/FM)**
 - for Tuner selects waveband: MW, FM (stereo) or FM (mono).
- ⑩ **OPEN/CLOSE**
 - open/close the CD door.
- ⑪ **STOP **
 - for CD/MP3 stops CD playback or erases a CD program.
- ⑫ **TUNING**
 - tunes to a radio station.
- ⑬ **DISPLAY**
 - display the current time.
- ⑭ **DBB (Dynamic Bass Boost)**
 - enhances the bass.
- ⑮ **VOLUME  / **
 - adjusts the volume level.

- ⑯ ****
 - connect headphones.
- ⑰ **Tape Deck Operation**
 - RECORD ** starts recording.
 - PLAY ** starts playback.
 - REW  / F.FWD ** fast rewinds/ forwards the tape.
 - STOP•OPEN ** stops the tape; opens the tape compartment.
 - PAUSE ** pauses recording or playback.
- ⑱ **REPEAT**
 - for CD/MP3 repeats a track/CD programme/ entire CD.
- ⑲ **SHUFFLE**
 - for CD/MP3 plays CD tracks in random order.
- ⑳ **SLEEP**
 - activates/deactivates or selects the sleeper time.
- ㉑ **MUTE**
 - switches playback sound off and on.
- ㉒ **TIMER ON/OFF**
 - activates/deactivates the timer.
- ㉓ **DSC (Digital Sound Control)**
 - selects sound characteristics: CLASSIC/JAZZ/ POP/ROCK.
- ㉔ ** / **
 - for CD/MP3 skips to the beginning of a current track/previous/next track (title).
for CD/MP3 (press and hold) fast searches back and forward within a track/ CD.
for clock/timer .. adjusts the hours and minutes for clock/timer functions.
- ㉕ **ALBUM-/+  / **
 - for MP3 selects an album.
- ㉖ **ALBUM+**
 - for MP3 selects an album upward.

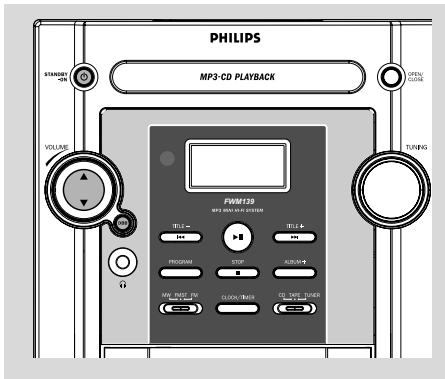

IMPORTANT:

Before you operate the system, complete the preparation procedures.

Switching the system on

- Press **STANDBY-ON** (POWER) on the remote).
→ The system will switch to the last selected source.

To switch the system to standby mode

- Press **STANDBY-ON** (POWER) on the remote).
→ The volume level (up to a maximum volume level of 15), interactive sound settings, last selected source and tuner presets will be retained in the player's memory.

Power-saving automatic standby

The power-saving feature automatically switches to standby 30 minutes after a tape or CD playback has ended and no control is operated.

Adjusting volume and sound

- 1 Press **VOLUME** ▲/▼ to increase or decrease volume.
→ Display shows the volume level $\bar{u}\bar{u}\bar{u}$ and a number from 0-40.

- 2 Press **DBB** to switch bass enhancement on or off.

→ Display shows: **DBB** if the DBB is activated.

- 3 Press **DSC** on the remote to repeatedly to select the desired sound effect: CLASSIC, JAZZ, POP or ROCK.

- 4 Press **MUTE** on the remote control to stop sound play-back instantly.
→ Playback will continue without sound and the display shows **MUTE**.

- To start sound playback you can:
 - press **MUTE** again;
 - adjust the volume controls.

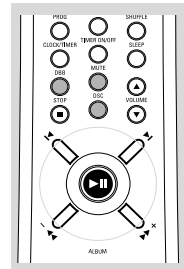

CD/MP3 Operation

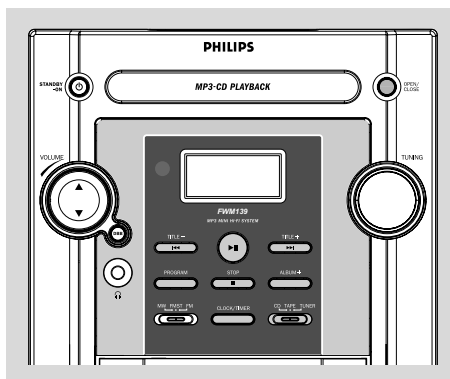

IMPORTANT:

The lens of the CD player should never be touched.

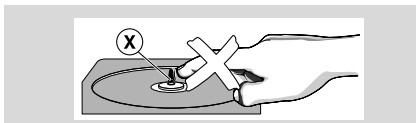

Playing a disc

This CD player plays Audio Discs including CD-Recordables, CD-Rewritables and MP3 CD.

- CD-ROM, CD-I, CDV, VCD, DVD or computer CDs, however, are not possible.
- 1 Adjust the source selector to select **CD** source.
 - 2 Press **OPEN/CLOSE** on the system to open the CD compartment.
→ *OPEN* is displayed when you open the CD compartment.
 - 3 Insert a disc with the printed side facing up and press **OPEN/CLOSE** to close the CD door.
→ *READ* is displayed as the CD player scans the contents of a disc, and then the total number of tracks and playing time (or the total number of albums and tracks for MP3 disc) are shown.
 - 4 Press **▶||** to start playback.
→ The current track number and elapsed playing time of the track are displayed during disc playback.

- 5 To pause playback press **▶||**. Press **▶||** again to resume play.

→ The display freezes and the elapsed playing time flashes when playback is interrupted.

- 6 To stop disc playback, press **STOP ■**.

Note: CD playback will also stop when;

– the CD door is opened.

– the disc has reached the end.

– you select another source: **TAPE, TUNER**.

– you select standby.

Selecting a different track

- Press **TITILE-/+** **◀◀** or **▶▶** (**◀/▶** on the remote) once or repeatedly until the desired track number appears in the display.
- Press **▶||** to start playback.

Finding a passage within a track

- 1 Press and hold down **TITILE-/+** **◀◀** or **▶▶** (**◀/▶** on the remote).
→ The disc is played at high speed and low volume.
- 2 When you find the passage you want, release **TITILE-/+** **◀◀** or **▶▶** (**◀/▶** on the remote).
→ Normal playback continues.

Playing an MP3 disc

- 1 Load an MP3 disc.
→ The disc reading time may exceed 10 seconds due to the large number of songs compiled into one disc.
→ "xx yyz" is displayed. xx is the current album number and yyz is the current track number.
- 2 Press **ALBUM+** (**ALBUM-/+** **◀◀** / **▶▶**) on the remote) to select a desired album.
- 3 Press **TITILE-/+** **◀◀** / **▶▶** (**◀/▶** on the remote) to select a desired track.
→ The album number will change accordingly as you reach the first track of an album by pressing **TITILE-** **◀◀** (**◀** on the remote) or the last track of an album by pressing **TITILE+** **▶▶** (**▶** on the remote).
- 4 Press **▶||** to start playback.

Supported MP3 disc formats:

- ISO9660, Joliet, UDF 1.5
- Maximum title number: 511 (depending on filename length)
- Maximum album number: 99
- Supported sampling frequencies: 32 kHz, 44.1 kHz, 48 kHz
- Supported Bit-rates: 32~256 (kbps), variable bitrates

Different play modes: SHUFFLE and REPEAT

You can select and change the various play modes before or during playback.

REPEAT plays the current track continuously

REPEAT ALL ... repeats the entire disc/programme

SHUF tracks of the entire disc are played in random order

SHUF and REPEAT ALL repeats the entire disc/programme continuously in random order

- 1** To select your play mode, press **SHUFFLE** or **REPEAT** on the remote control before or during playback until the display shows the desired function.
 - 2** Press **▶II** to start playback if in the STOP position.
 - 3** To return to normal playback, press **SHUFFLE** or **REPEAT** on the remote control until the various SHUFFLE/ REPEAT modes are no longer displayed.
- You can also press **STOP ■** to cancel your play mode.

Programming track numbers

Programme in the STOP position to select and store your disc tracks in the desired sequence. If you like, store any track more than once. Up to 20 tracks can be stored in the memory.

- 1** Press **PROGRAM (PROG)** on the remote) to enter the programming mode.
- 2** Use **TITILE-/+ ◀◀ / ▶▶ (◀/▶)** on the remote) to select your desired track number.
→ The selected track number and **PROG** flash on the display panel.
- 3** Press **PROGRAM (PROG)** on the remote control) to confirm the track number to be stored.
- 4** Repeat steps **2-3** to select and store all desired tracks.
- 5** To start playback of your disc programme, press **▶II**

Note:

- *If you wish, you can add further tracks to your current program. Make sure you are in the STOP position, and that you have not exceeded 20 tracks.*

Erasing the programme

You can erase the programme by:

- pressing **STOP ■** once in the STOP mode;
- pressing **STOP ■** twice during playback;
- opening the CD compartment;
- selecting another sound source
→ **PROG** disappears from the display.

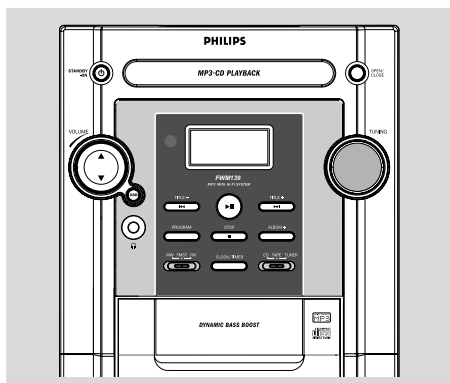

Tuning to radio stations

- 1 Adjust the source selector to select **TUNER** source.
→ **TUNER** is displayed.
- 2 Adjust the band selector to select your waveband: MW, FM (mono) or FMST (stereo).
- 3 Adjust the TUNING control knob to tune to a desired radio frequency.

Note:

– The system is equipped with a built-in MW antenna and a fixed FM antenna. For optimal MW reception, adjust the position of the whole set until the strongest signal is found. For optimal FM reception, fully extend and adjust the position of the FM antenna until the strongest signal is found.

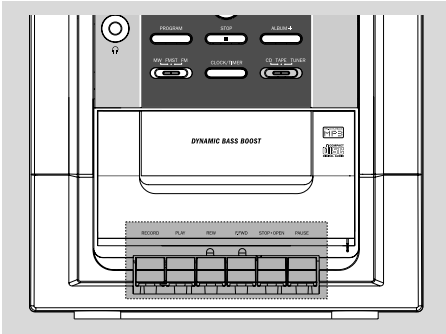

Tape playback

- 1 Adjust the source selector to select **TAPE** source.
→ Display: shows **TAPES** throughout tape operation.
- 2 Press **STOP•OPEN** ■ ▲ to open the tape door.
- 3 Insert a recorded tape and close the tape door.
→ Load the tape with the open side downward and the full spool to the left.
- 4 Press **PLAY** ► to start playback.
- 5 To pause, press **PAUSE** ■■. Press again to resume.
- 6 Press **REW** ◀◀ or **F.FWD** ▶▶ to fast wind tape in either direction.
- 7 To stop the tape, press **STOP•OPEN** ■ ▲.

Notes:

- During playback, the keys are automatically released at the end of a tape. To switch off the set, press **STANDBY-ON** ⏻ (POWER ⏻ on the remote).
- During fast forwarding/rewinding, the keys will not be released at the end of a tape. To stop fast winding, press **STOP•OPEN** ■▲.

General information on recording

- Recording is permissible insofar as copyright or other rights of third parties are not infringed.
- For recording, use only **NORMAL** (IEC type I) tapes on which the tabs have not yet been broken. This deck is not suited for recording on **METAL** (IEC IV) type tapes.
- The best recording level is set automatically. Altering the **VOLUME** or **DBB** controls will not affect the recording in progress.
- The recording sound quality might differ depending on the quality of your recording source and the recording tape.
- At the very beginning and end of the tape, no recording will take place during the 7 seconds when the leader tape passes the recorder heads.
- To protect a tape from accidental erasure, have the tape in front of you and break out the left tab. Recording on this side is no longer possible. If, however, you wish to record over this side again, cover the tabs with a piece of adhesive tape.

Synchro start CD recording

- 1 Adjust the source selector to select **CD** source.
- 2 Insert a disc and if desired, programme track numbers.
- 3 Press **STOP•OPEN** ■ ▲ to open the tape door.
- 4 Insert a suitable tape into the deck and close the tape door.
- 5 Press **RECORD** ● to start recording.
→ Playing of the CD programme starts automatically from the beginning of the CD after 7 seconds. It is not necessary to start the CD player separately.

Tape Operation / Recording

To select and record a particular passage within a CD track:

- Press and hold down on **REW** ◀◀ or **F.FWD** ▶▶. Release the control when you recognize the passage you want.
 - To interrupt CD playback press ▶◻◻.
 - Recording starts from this exact point in the track when you press **RECORD** ●.
- 6 To pause, press **PAUSE** ◻◻. Press again to resume.
 - 7 To stop recording, press **STOP•OPEN** ◻ ◻.

Recording from the radio

- 1 Tune to the desired radio station (see Tuning to radio stations).
- 2 Press **STOP•OPEN** ◻ ◻ to open the tape door.
- 3 Insert a suitable tape into the deck and close the tape door.
- 4 Press **RECORD** ● to start recording.
- 5 To pause, press **PAUSE** ◻◻. Press again to resume.
- 6 To stop recording, press **STOP•OPEN** ◻ ◻.

Maintenance

Cleaning the Cabinet

- Use a soft cloth slightly moistened with a mild detergent solution. Do not use a solution containing alcohol, spirits, ammonia or abrasives.

Cleaning Discs

- When a disc becomes dirty, clean it with a cleaning cloth. Wipe the disc from the centre out.
- Do not use solvents such as benzene, thinner, commercially available cleaners, or antistatic spray intended for analogue records.

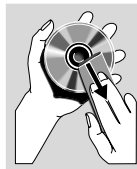

Cleaning the disc lens

- After prolonged use, dirt or dust may accumulate at the disc lens. To ensure good playback quality, clean the disc lens with Philips CD Lens Cleaner or any commercially available cleaner. Follow the instructions supplied with cleaner.

Cleaning the Heads and the Tape Paths

- To ensure good recording and playback quality, clean the heads (A), the capstan(s) (B), and pressure roller(s) (C) after every 50 hours of tape operation.
- Use a cotton swab slightly moistened with cleaning fluid or alcohol.
- You can also clean the heads by playing a cleaning tape once.

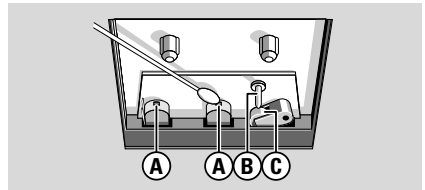

Demagnetising the heads

- Use a demagnetising tape available at your dealer.

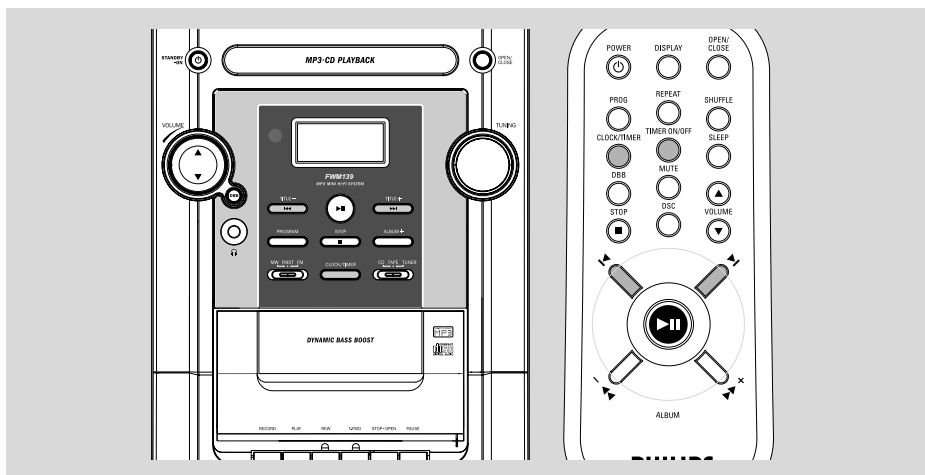

Setting the clock

- 1 In any mode, press **CLOCK/TIMER** twice.
→ The clock digits for the hours flash.
- 2 Press **TITLE-/+ |◀◀ / ▶▶** (|◀/▶| on the remote) to set the hours.
- 3 Press **CLOCK/TIMER** again.
→ The clock digits for the minutes flash.
- 4 Press **TITLE-/+ |◀◀ / ▶▶** (|◀/▶| on the remote) to set the minutes.
- 5 Press **CLOCK/TIMER** to confirm the time.

Note:

– If the clock has not been set, 0:00 will be displayed.

Setting the timer

- The system can be used as an alarm clock. CD or TUNER can be set to switch on at a preset time. The clock time needs to be set first before the timer can be used.
- If no button is pressed within 7 seconds during timer setup, the system will exit timer setting mode automatically.

- 1 In active mode, press and hold **CLOCK/TIMER** for more than 2 seconds.
- 2 Press **TITLE-/+ |◀◀ / ▶▶** (|◀/▶| on the remote) to set the hours.
- 3 Press **CLOCK/TIMER** again.
→ The clock digits for the minutes flash.
- 4 Press **TITLE-/+ |◀◀ / ▶▶** (|◀/▶| on the remote) to set the minutes.
- 5 Press **CLOCK/TIMER** to confirm the time
→ The timer is now set and actiated.

Activating and deactivating TIMER

- In standby or during playback, press **TIMER ON/OFF** once.
→ Display shows  if activated, and disappears if deactivated.

Clock/Timer

Activating and deactivating SLEEP

The sleep timer enables the system to switch off by itself after a set period of time

- Press **SLEEP** on the remote control repeatedly to select desired time before system shuts off.

→ Display shows **SLEEP** and series of time options for selection: 120, 90, 60, 45, 30, 15, OFF.

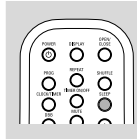

- To deactivate, press **SLEEP** on the remote control once or more until 'OFF' is shown, or press **STANDBY-ON** (POWER) on the remote).

Specifications

AMPLIFIER

Output power 2 x 20 W RMS
..... 800W PMPO
Signal-to-noise ratio \geq 62 dBA (IEC)
Frequency response 63 – 16000 Hz, \pm 3 dB
Impedance loudspeakers 8 Ω
Impedance headphones 32 Ω – 1000 Ω

CD PLAYER

Frequency range 63 – 16000 Hz
Signal-to-noise ratio 65 dBA

TUNER

FM wave range 87.5 – 108 MHz
MW wave range 522 – 1710 kHz

TAPE DECK

Frequency response
Normal tape (type I) 125 – 8000 Hz (8 dB)
Signal-to-noise ratio
Normal tape (type I) 35 dBA
Wow and flutter \leq 0.4% DIN

SPEAKERS

Bass reflex system
Dimensions (w x h x d) . 190 x 292 x 182 (mm)

GENERAL INFORMATION

AC Power 110 – 127 / 220 – 240 V
..... 50/60 Hz Switchable
Dimensions (w x h x d) .. 220 x 292 x 285 (mm)
Weight (with/without speakers)
..... approx. 4.9 / 2.3 kg

Subject to modification

WARNING

Under no circumstances should you try to repair the system yourself, as this will invalidate the warranty. Do not open the system as there is a risk of electric shock.

If a fault occurs, first check the points listed below before taking the system for repair. If you are unable to remedy a problem by following these hints, consult your dealer or service centre.

| Problem | Solution |
|-----------------------------------------------------|--------------------------------------------------------------------------------------------------------------------------------------------------------------------------------------------------------------------------------------------------------------------------------------------------------------|
| CD OPERATION | |
| "No disc" is displayed. | <ul style="list-style-type: none"> - Insert a disc. - Check if the disc is inserted upside down. - Wait until the moisture condensation at the lens has cleared. - Replace or clean the disc, see "Maintenance". - Use a finalised CD-RW, CD-R or MP3 CD. |
| RADIO RECEPTION | |
| Radio reception is poor. | <ul style="list-style-type: none"> - Increase the distance between the Micro HiFi System and your TV or VCR. |
| TAPE OPERATION / RECORDING | |
| Recording or playback cannot be made. | <ul style="list-style-type: none"> - Clean deck parts, see "Maintenance". - Use only normal (IEC I) tape for recording. - Apply a piece of adhesive tape over the missing tab space. |
| GENERAL | |
| The system does not react when buttons are pressed. | <ul style="list-style-type: none"> - Remove and reconnect the AC power plug and switch on the system again. |
| Sound cannot be heard or is of poor quality. | <ul style="list-style-type: none"> - Adjust the volume. - Disconnect the headphones. - Check that the speakers are connected correctly. - Check if the stripped speaker wire is clamped. |
| The left and right sound outputs are reversed. | <ul style="list-style-type: none"> - Check the speaker connections and location. |

Troubleshooting

The remote control does not function

- Reduce the distance between the remote control and the system.
- Insert the batteries with their polarities (+/- signs) aligned as indicated.
- Replace the batteries.
- Point the remote control directly toward IR sensor on the front of the system.

The timer is not working.

- Set the clock correctly.
- Press **TIMER ON/OFF** to switch on the timer.
- If a recording is in progress, stop the recording.

The Clock/Timer setting is erased.

- Power has been interrupted or the power cord has been disconnected. Reset the clock/timer.
-