

CD Soundmachine

AZ1017

Meet Philips at the Internet

<http://www.philips.com>

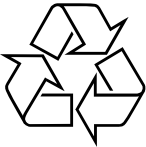

AZ 1017

PHILIPS



Printed in China

JH-0607

1

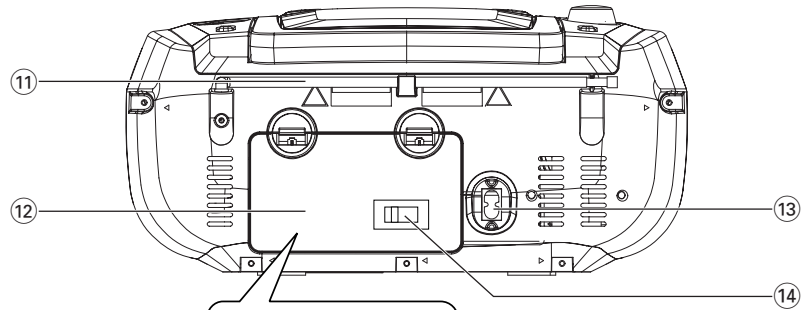
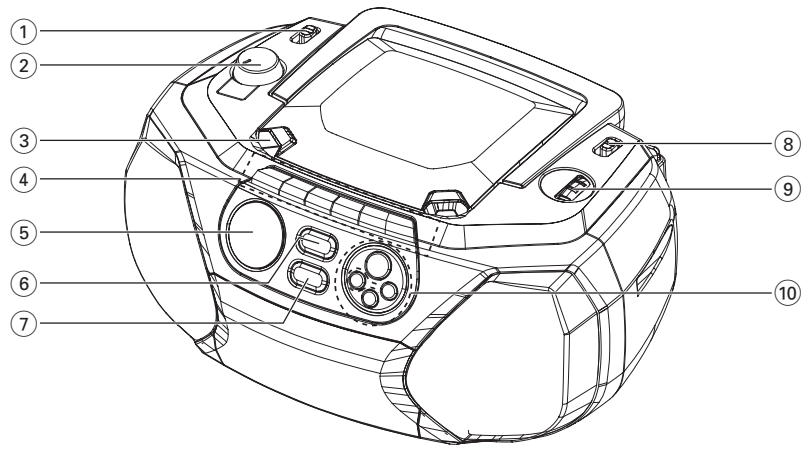

6xR14•UM-2•C-CELLS

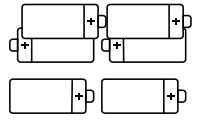

2

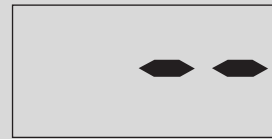

3



4



5



6



7

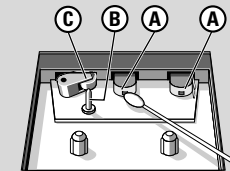
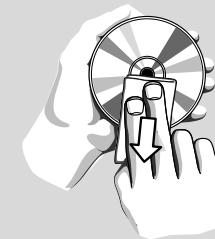
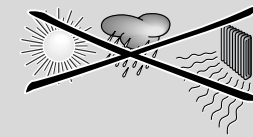

English

Supplied accessories

– AC power cord

Top and front panels (See 1)

- ① **Source selector: CD, TUNER, TAPE/OFF**
– selects CD, tuner (MW or FM) or tape source of sound
– switch off the set
- ② **VOLUME** – adjusts volume level
- ③ **LIFT-OPEN** – opens the CD door
- ④ **MIC (built-in microphone)** – for voice recording via cassette recording
- ⑤ **Cassette recorder keys:**
II – pauses playback or recording
■▲ – stops the tape;
– opens the cassette holder
◀◀ or **▶▶** – fast winds/ rewinds tape
◀ – starts playback
● – starts recording
- ⑥ **CD Display** – shows the CD functions
- ⑦ **PROG** – programs and reviews programmed track numbers
- ⑧ **REPEAT** – repeats a track/
CD program/entire CD
- ⑨ **BAND** – selects FM or MW waveband
- ⑩ **TUNING** – tunes to radio stations
- ⑪ **▶II** – starts or pauses CD playback.
■ – stop playback;
– erases a CD program
◀◀, ▶▶ – skips or searches a passage/track backwards

Back panel (See 1)

- ⑫ **Telescopic antenna** – improves FM reception
- ⑬ **Battery compartment** – open to insert 6 x 1.5V **R-14/ UM2/ C-cells**

Controls/Power Supply

- ⑭  – 3.5 mm stereo headphone socket
Helpful hints: *The speakers will be muted when headphones are connected to the set.*
- ⑮ **AC MAINS** – inlet for power cord
- ⑯ **Voltage selector** – adjust to match the local voltage 110/220V before plugging in the set

CAUTION

-Visible and invisible laser radiation. If the cover is open, do not look at the beam.

- High voltage! Do not open. You run the risk of getting an electric shock. The machine does not contain any user-serviceable parts.

- Modification of the product could result in hazardous radiation of EMC or other unsafe operation.

Power Supply

Whenever convenient, use the mains supply cord if you want to conserve battery life. Make sure you remove the plug from the set and wall outlet before inserting batteries.

Batteries (not included)

- 1 Open the battery compartment and insert six batteries, type **R-14, UM-2** or **C-cells**, (preferably alkaline) with the correct polarity as indicated by the "+" and "-" symbols inside the compartment. (See 1)
- 2 Replace the compartment door, making sure the batteries are firmly and correctly in place. The set is now ready to operate.

Batteries contain chemical substances, so they should be disposed of properly.

- Incorrect use of batteries can cause electrolyte leakage and will corrode the compartment or cause the batteries to burst:

Power Supply

- Do not mix battery types: e.g. alkaline with carbon zinc. Only use batteries of the same type for the set.
- When inserting new batteries, do not try to mix old batteries with the new ones.
- Remove the batteries if the set is not to be used for a long time.

Using AC Mains

- 1 Check if the power/mains voltage, **as shown on the type plate located on the bottom of the set**, corresponds to your local power supply. If it does not, consult your dealer or service center.
 - 2 If your set is equipped with a voltage selector, adjust the selector so that it matches with the local power supply.
 - 3 Connect the power cord to the AC MAINS inlet and the wall socket. The mains lead is now connected and ready for use.
 - 4 To switch the set off completely, withdraw the power cord from the wall socket.
 - 5 Install the unit near the AC outlet and where the AC power plug can be easily reached.
- Disconnect the mains lead from the wall socket to protect your set during heavy thunderstorms. Children could seriously injure themselves as the free end of the cable may still be live if only the connector is removed from the MAINS socket at the back of the unit.

The type plate is located on the bottom of the set.

Helpful hints :

- To avoid unnecessary energy consumption, always adjust the **source selector** to **TAPE/OFF** after using the set, and also check that the tape deck keys are released.

Basic operation/Radio

Basic operation

- 1 To select your sound source, adjust the **source selector** to : **CD, TUNER** or **TAPE/OFF**.
- 2 To switch off the set, adjust the **source selector** to **TAPE/OFF** position and check the cassette keys are released.

Helpful hints:

- To change from **TAPE** to **TUNER** or **CD** function, or when you are switching off the set: first, make sure you press the tape **■▲** key to end playback and all the cassette keys are released.

Adjusting volume

Adjust the volume with the **VOLUME** control.

Radio reception

- 1 Adjust the **source selector** to **TUNER**.
 - 2 Adjust **BAND** to **FM** or **MW** as your desired band.
 - 3 Turn **TUNING** to tune to a station.
- For **FM**, extend and turn the telescopic antenna for best reception. Reduce its length if the signal is too strong.
 - For **MW**, the set uses a built-in antenna. Direct this antenna for best reception by turning the whole set.
- 4 To switch off the radio, adjust the source selector to **TAPE/OFF** position and check the cassette keys are released.

CD Player

Playing a CD

This CD player plays Audio Discs including CD-Recordables and CD-Rewritable.

- MP3 CD-ROMs, CD-I, CDV, VCD, DVD or computer CDs are not possible for playback on this set.

IMPORTANT!

- CDs encoded with **copyright protection technologies** by some record companies may be unplayable by this product.

- 1 Adjust the **source selector** to **CD**.
- 2 Open the disc door.
- 3 Insert a CD with the printed side facing up and press the CD door gently to close.
→ Display shows - - and later, the total number of tracks. (See [2], [3])
- 4 Press **▶II** on the set to start playback.
→ Display: ▶ and the current track number. (See [4])
- 5 To pause playback press **▶II**. To resume playback, press **▶II** again.
- 6 To stop CD play, press **■**.

Helpful hints :

CD play will also stop when:

- you open the CD compartment;
- you select **TUNER**, or **TAPE/OFF** sound source;
- the CD has reached the end of playback.

Selecting a different track

- Press **◀◀** or **▶▶** once or repeatedly until the desired track number appears in the display.
- In the stop/pause position, press **▶II** to start playback.

Finding a passage within a track

- 1 During playback, press and hold down **◀◀/▶▶**.
→ The CD is played at high speed and low volume.
- 2 When you recognize the passage you want release **◀◀/▶▶**.
→ Normal playback resumes.

Helpful hints :

- When your searching reaches the end of the last track, the CD goes to stop mode.

CD Player

Programming track numbers

You may store up to 20 tracks in the desired sequence. If you like, store any track more than once.

- 1 In the stop position, press **PROG** to activate programming.
→ Display: **PROG** and **⏸** flash (see [5]).
- 2 Press **◀◀** or **▶▶** to select your desired track number.
→ Display: **PROG** and your desired track number flash.
- 3 Press **PROG** to store the desired track number.
→ Display: **PROG** and **⏸** flash for you to program the next track.
- 4 Repeat steps **2** to **3** to select and store all desired tracks in this way.
- 5 To play your program, press **▶II**.
→ Display: **PROG** flashes during program playback. **Helpful hints :**
 - If you try to store more than 20 tracks, no track can be selected and the display will show flashing - - .

To review a program

- In the stop position, press **PROG** repeatedly to see your stored track numbers.

Erasing a program

You can erase the contents of the memory by:

- in the stop position, press **PROG** to enter program mode, and then press **■**;
- Selecting **TUNER** or **TAPE/OFF** sound source;
- opening the CD door.
→ Display: **PROG** disappears.

Different play mode: REPEAT(see [6]):

REPEAT

You can play the current track or the whole disc repeatedly, and combine REPEAT modes with PROGRAM.

REPEAT – plays the current track continuously.

REPEAT ALL– repeats the entire CD/program.

- 1 To select play mode, press **REPEAT** once or more.
→ The display shows selected mode.
- 2 Press **▶II** to start playback if in the stop/pause position.
- 3 To return to normal playback, press **REPEAT** repeatedly until the modes are no longer displayed.
– You can also press **■** to cancel your play mode.

Cassette Recorder

Cassette playback

- 1 Adjust the **source selector** to **TAPE/OFF**.
- 2 Press **■▲** to open the cassette holder, and insert a cassette and close the deck.
- 3 Press **◀** to start playback.
- 4 To pause playback press **II**.
- 5 To resume, press **II** again.
- 6 To stop the tape, press **■▲**.

Fast forwarding/rewinding

- 1 Press **◀◀** or **▶▶** until you reach your desired passage.
- 2 Press **■▲** to stop rewinding/fast forwarding.

Helpful hints :

- The keys are automatically released at the end of a tape and the set is switched off (unless PAUSE mode **II** has been activated.)
- During fast forwarding/rewinding, the keys will not be released at the end of a tape. To switch off the set, make sure the cassette keys are also released.

General information on recording

- Recording is permissible insofar as copyright or other rights of third parties are not infringed.
- For recording, use only NORMAL type cassettes (IEC type I) on which the tabs have not yet been broken. This deck is not suited for recording on CHROME (IEC II) or METAL (IEC IV) type cassettes.
- The best recording level is set automatically. Altering the **VOLUME** will not affect the recording.
- To protect a tape from accidental erasure, break out the tabs. If you wish to record again, cover the tabs with a piece of adhesive tape.

CD synchro start recording

- 1 Select **CD** source.
- 2 Insert a CD and if desired, program track numbers.
- 3 Press **■▲** to open the cassette holder. Insert a blank tape and close the deck.
- 4 Press **●** to start recording.
→ Playing of the CD program starts automatically from the beginning of the program. It is not necessary to start the CD player separately.
- 5 For brief interruptions press **II**. To resume recording, press **II** again.
- 6 To stop recording, press **■▲**.

Recording from the Radio

- 1 Adjust the **source selector** to **TUNER**.
- 2 Adjust **BAND** to **FM** or **MW** as your desired band.
- 3 Tune to the desired radio station (see **Radio reception**).
- 4 Follow steps 3-6 under **CD synchro start recording**.

Recording your voice

- 1 Select **TAPE** source.
- 2 Follows steps 3-4 under **Recording from the CD Player**.
- 3 Speak towards the built-in microphone (located on the left speaker, see **1**).
- 4 Follows steps 6-7 under **Recording from the CD Player**.

The making of unauthorized copies of copy-protected material, including computer programmes, files, broadcasts and sound recordings, may be an infringement of copyrights and constitute a criminal offence. This equipment should not be used for such purposes.



Safety & Maintenance (See **7**)

Safety information

- Place the set on a hard, flat and stable surface so that the system does not tilt.
- Do not expose the set, batteries, CDs to humidity, rain, sand or excessive heat caused by heating equipment or direct sunlight.
- Do not expose the apparatus to dripping or splashing.
- Adequate ventilation with a minimum gap of 6 inches between the ventilation holes and surrounding surfaces is necessary to prevent heat build-up.
- The ventilation should be impeded by covering the ventilation openings with items, such as newspapers, table-cloths, curtains, etc..
- No objects filled with liquids, such as vases, shall be placed on the apparatus.
- No naked flame sources, such as lighted candles, should be placed on the apparatus.
- The mechanical parts of the set contain self-lubricating bearings and must not be oiled or lubricated.
- To clean the set, use a dry cloth. Do not use any cleaning agents containing alcohol, ammonia, benzene or abrasives as these may harm the housing.

Tape deck maintenance

To ensure quality recording and playback of the tape deck, clean parts **(A)**, **(B)** and **(C)** as shown, once a month. Use a cotton bud slightly moistened with alcohol or a special head cleaning fluid to clean the deck.

- 1 Open the cassette holder by pressing **■▲**.
- 2 Press **◀** and clean the roller **(C)**.
- 3 Press **II** and clean the heads **(A)**, and the capstan **(B)**.
- 4 After cleaning, press **■**.
→ Cleaning of the heads can also be done by playing a cleaning cassette through once.

CD player and CD handling

- If the CD player cannot read CDs correctly, use a cleaning CD to clean the lens before taking the set to repair.
- The lens of the CD player should never be touched!
- Sudden changes in the surrounding temperature can cause condensation on the lens of your CD player. Playing a CD is then not possible. Do not attempt to clean the lens but leave the set in a warm environment until the moisture evaporates.
- Always close the CD-tape door to avoid dust on the lens.
- To clean the CD, wipe in a straight line from the center towards the edge using a soft, lint-free cloth. Do not use cleaning agents as they may damage the disc.
- Never write on a CD or attach any stickers to it.

Troubleshooting

If a fault occurs, first check the points listed below before taking the set for repair.
If you are unable to remedy a problem by following these hints, consult your dealer or service centre.

WARNING: *Do not open the set as there is a risk of electric shock. Under no circumstances should you try to repair the set yourself, as this will invalidate the guarantee.*

Problem

- Possible cause
- Remedy

No sound /power

- Volume not adjusted
- Adjust the VOLUME
- Power cord not securely connected
- Connect the AC power cord properly
- Batteries dead/ incorrectly inserted
- Insert (fresh) batteries correctly
- CD contains non-audio files
- Press ◀◀, ▶▶ once or more to skip to a CD audio track, instead of the data file.

Display does not function properly/ No reaction to operation of any of the controls

- Electrostatic discharge
- Switch off and unplug the set. Reconnect after a few seconds

The CD skips tracks

- CD damaged or dirty
- Replace or clean CD
- Program is active
- Quit program mode

Note:

Make sure the CD is not encoded with Copyright protection technologies, as some do not conform to the Compact Disc standard.

- - indication

- No CD inserted
- Insert a CD
- CD badly scratched or dirty
- Replace/ clean CD, see Maintenance
- Laser lens steamed up
- Wait until lens has cleared
- CD-R(W) is blank or not finalized
- Use a finalized CD-R(W) or suitable CD Audio disc only

Poor cassette sound quality

- Dust and dirt on the heads, etc.
- Clean deck parts, see Maintenance
- Use of incompatible cassette types (METAL or CHROME)
- Only use NORMAL (IEC I) for recording

Recording does not work

- Cassette tab(s) may be broken
- Apply adhesive tape over the missing tab space

Environmental information

All unnecessary packaging material has been omitted. The packaging can be easily separated into three materials: cardboard, polystyrene and plastic.

Your set consists of materials which can be recycled if disassembled by a specialized company. Please observe the local regulations regarding the disposal of packaging, dead batteries and old equipment.