

Micro Hi-Fi System

MC108C

user manual



PHILIPS

Important notes for users in the U.K.

Mains plug

This apparatus is fitted with an approved 13 Amp plug. To change a fuse in this type of plug proceed as follows:

- 1 Remove fuse cover and fuse.
- 2 Fix new fuse which should be a BS1362 3 Amp, A.S.T.A. or BSI approved type.
- 3 Refit the fuse cover.

If the fitted plug is not suitable for your socket outlets, it should be cut off and an appropriate plug fitted in its place.

If the mains plug contains a fuse, this should have a value of 3 Amp. If a plug without a fuse is used, the fuse at the distribution board should not be greater than 3 Amp.

Note: The severed plug must be disposed of to avoid a possible shock hazard should it be inserted into a 13 Amp socket elsewhere.

How to connect a plug

The wires in the mains lead are coloured with the following code: blue = neutral (N), brown = live (L).

- As these colours may not correspond with the colour markings identifying the terminals in your plug, proceed as follows:
 - Connect the blue wire to the terminal marked N or coloured black.
 - Connect the brown wire to the terminal marked L or coloured red.
 - Do not connect either wire to the earth terminal in the plug, marked E (or \perp) or coloured green (or green and yellow).

Before replacing the plug cover, make certain that the cord grip is clamped over the sheath of the lead - not simply over the two wires.

Copyright in the U.K.

Recording and playback of material may require consent. See Copyright Act 1956 and The Performer's Protection Acts 1958 to 1972.

CAUTION

Use of controls or adjustments or performance of procedures other than herein may result in hazardous radiation exposure or other unsafe operation.

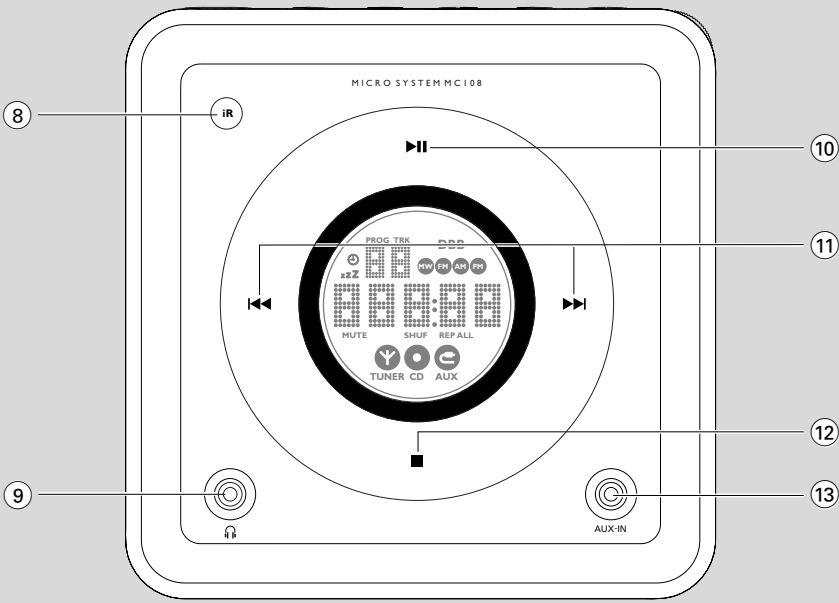
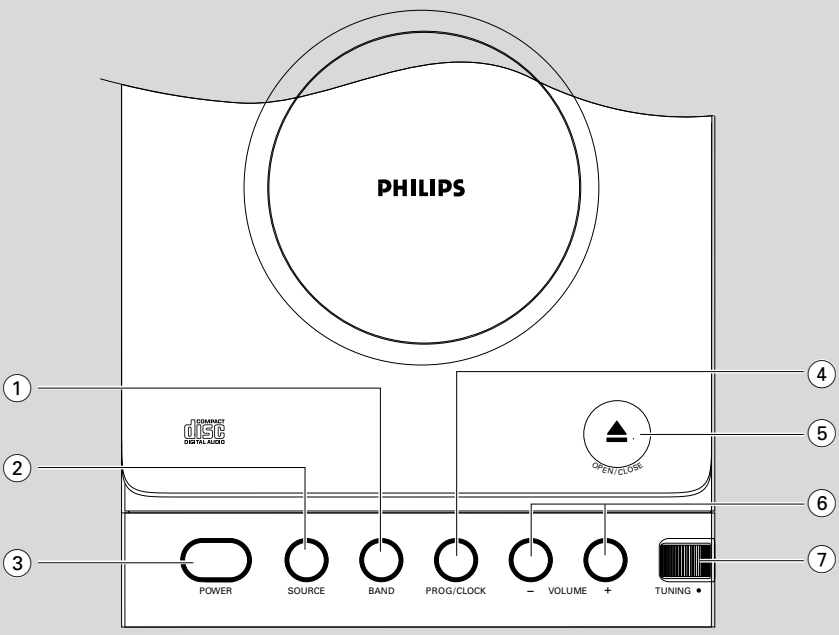

Contents

General Information

Environmental information	5
Supplied accessories	5
Safety information	5

Preparation

Rear connections	6–7
Before using the remote control	7
Replacing battery (lithium CR2032) into the remote control	7

Controls

Controls on the system and remote control	8
----------------------------------------------------	---

Basic Functions

Switching the system on	9
Power-saving automatic standby	9
Adjusting volume and sound	9

CD Operation

Playing a disc	10
Selecting a different track	10
Finding a passage within a track	10
Different play modes: Shuffle and Repeat	11
Programming track numbers	11
Erasing the programme	11

Radio Reception

Tuning to radio stations	12
--------------------------------	----

Maintenance	12
--------------------------	----

Clock/Timer

Setting the clock	13
Setting the timer	13
Activating and deactivating TIMER	13
Activating and deactivating SLEEP	14

Specifications	14
-----------------------------	----

Troubleshooting	15
------------------------------	----

This product complies with the radio interference requirements of the European Community.

Supplied accessories

- 2 speaker boxes
- remote control with battery
- AM loop antenna

Environmental Information

All unnecessary packaging has been omitted. We have tried to make the packaging easy to separate into three materials: cardboard (box), polystyrene foam (buffer) and polyethylene (bags, protective foam sheet).

Your system consists of materials which can be recycled and reused if disassembled by a specialized company. Please observe the local regulations regarding the disposal of packaging materials, exhausted batteries and old equipment.

Disposal of your old product

Your product is designed and manufactured with high quality materials and components, which can be recycled and reused.



When this crossed-out wheeled bin symbol is attached to a product it means the product is covered by the European Directive 2002/96/EC

Please inform yourself about the local separate collection system for electrical and electronic products.

Please act according to your local rules and do not dispose of your old products with your normal household waste. The correct disposal of your old product will help prevent potential negative consequences for the environment and human health.

Safety Information

- Before operating the system, check that the operating voltage indicated on the typeplate (or the voltage indication beside the voltage selector) of your system is identical with the voltage of your local power supply. If not, please consult your dealer.
- Place the system on a flat, hard and stable surface.
- Place the system in a location with adequate ventilation to prevent internal heat build-up in your system. Allow at least 10 cm (4 inches) clearance from the rear and the top of the unit and 5 cm (2 inches) from each side.
- The ventilation should not be impeded by covering the ventilation openings with items, such as newspapers, table-cloths, curtains, etc.
- Do not expose the system, batteries or discs to excessive moisture, rain, sand or heat sources caused by heating equipment or direct sunlight.
- No naked flame sources, such as lighted candles, should be placed on the apparatus.
- No objects filled with liquids, such as vases, shall be placed on the apparatus.
- If the system is brought directly from a cold to a warm location, or is placed in a very damp room, moisture may condense on the lens of the disc unit inside the system. Should this occur; the CD player would not operate normally. Leave the power on for about one hour with no disc in the system until normal playback is possible.
- The mechanical parts of the set contain self-lubricating bearings and must not be oiled or lubricated.
- **When the system is switched to Standby mode, it is still consuming some power. To disconnect the system from the power supply completely, remove the AC power plug from the wall socket.**

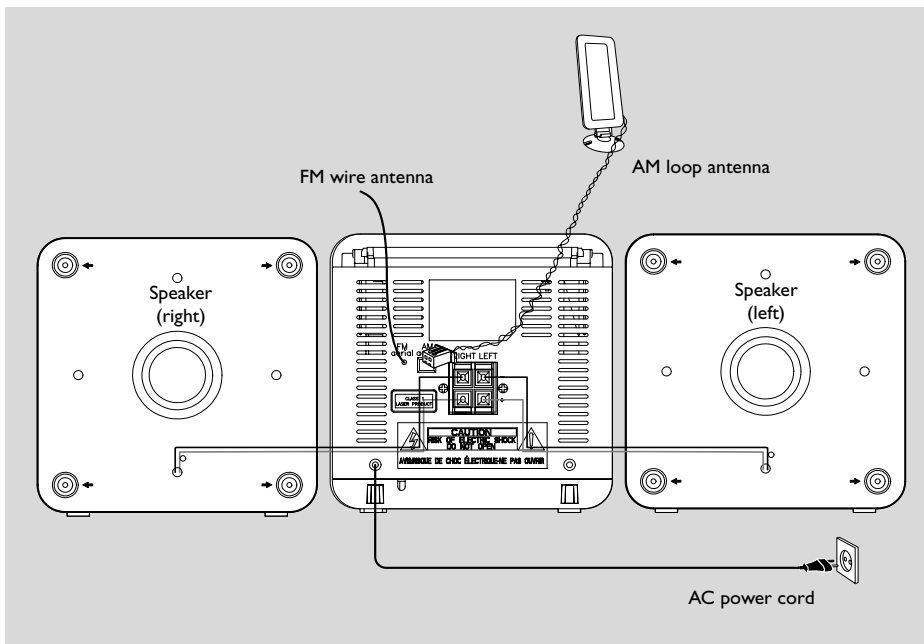

Rear connections

The type plate is located at the rear of the system.

For users in the U.K.: please follow the instructions on page 2.

A Power

– Before connecting the AC power cord to the wall outlet, ensure that all other connections have been made.

WARNING!

- For optimal performance, use only the original power cable.
- Never make or change any connections with the power switched on.

B Antennas Connection

AM (MW) antenna

- 1 Unfold the loop antenna and if necessary, use screws (not supplied) to fix it to a flat, hard and stable place:

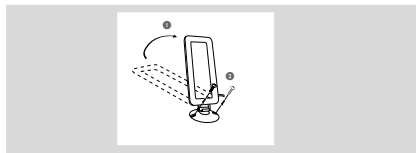

- 2 Fit the plug of the loop antenna to AM ANTENNA as shown above.
 - 3 Adjust the antenna for optimal reception
- Position the antenna as far as possible from a TV, VCR or other radiation source.

C Speakers Connection

Front Speakers

Connect the speaker wires to the SPEAKERS terminals, right speaker to "RIGHT" and left speaker to "LEFT", coloured (marked) wire to "+" and black (unmarked) wire to "-".

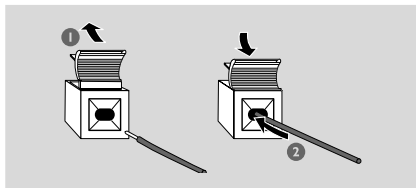

- Fully insert the stripped portion of the speaker wire into the terminal as shown.

Notes:

- For optimal sound performance, use the supplied speakers.
- Do not connect more than one speaker to any one pair of + / - speaker terminals.
- Do not connect speakers with an impedance lower than the speakers supplied. Please refer to the SPECIFICATIONS section of this manual.

Before using the remote control

- 1 Pull out the plastic protective sheet.
- 2 Select the source you wish to control by pressing one of the source select keys on the remote control (for example CD, TUNER).
- 3 Then select the desired function (for example ►, ◀, ▶).

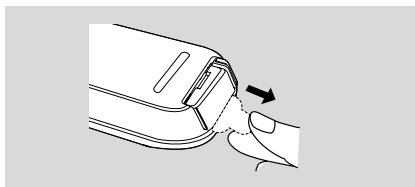

Replacing battery (lithium CR2032) into the remote control

- 1 Pull out the knob (A) slightly to the left.
- 2 Pull out the battery compartment (B).
- 3 Replace a new battery and fully insert the battery compartment back to the original position.

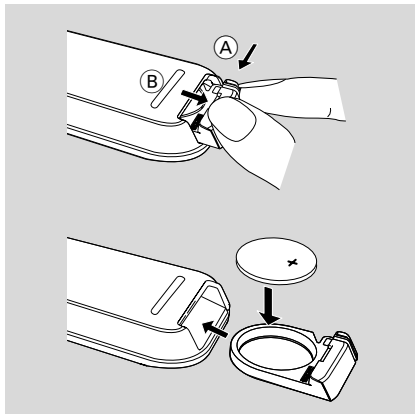

CAUTION!

Batteries contain chemical substances, so they should be disposed off properly.

Controls (illustrations on page 3)

Controls on the system and remote control

- ① **BAND**
 - for Tuner (on the set only) selects waveband.
- ② **SOURCE (CD/TUNER/AUX)**
 - switches on the system.
 - selects the respective sound source for CD/ FM/ MW/ AUX.
- ③ **POWER / ⏻**
 - switches the system to standby/on.
- ④ **PROG/CLOCK**
 - for CD programs tracks and reviews the program.
 - for clock sets the clock function.
- ⑤ **OPEN•CLOSE**
 - opens/closes the CD door.
- ⑥ **VOLUME – / +**
 - adjusts volume level.
- ⑦ **TUNING ●**
 - tunes to radio stations.
- ⑧ **IR SENSOR**
 - infrared sensor for remote control.
- ⑨ **🎧**
 - connect headphones.
- ⑩ **▶ ||**
 - for CD starts or pauses CD playback.
- ⑪ **⏮ / ⏭**
 - skips to the beginning of a current track/ previous/ next track.
 - fast searches back and forward within a track/ CD.
- ⑫ **STOP ■**
 - stops CD playback or erase a CD program.
- ⑬ **AUX IN**
 - connects to external audio source.
- ⑭ **REPEAT**
 - repeats a track/CD program/ entire CD.
- ⑮ **SHUFF (SHUFFLE)**
 - plays CD tracks in random order.
- ⑯ **SLEEP**
 - activates/deactivates or selects the sleeper time.
- ⑰ **TIMER**
 - activates/deactivates or sets the timer function.

- ⑱ **DBB**
 - (Dynamic Bass Boost) enhances the bass.
- ⑲ **MUTE**
 - switches playback sound off and on.

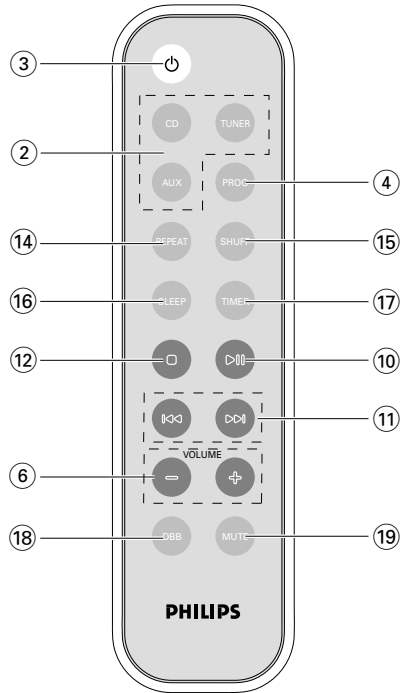

Notes for remote control:

- First select the source you wish to control by pressing one of the source select keys on the remote control (for example CD, TUNER).
- Then select the desired function (for example ▶, ⏮, ⏭).

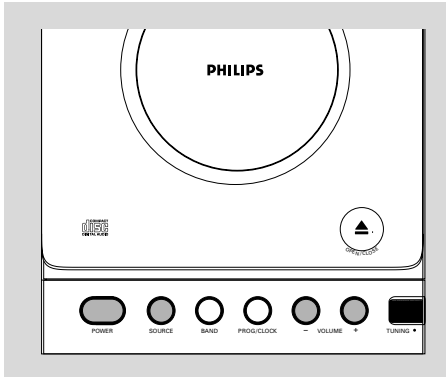

IMPORTANT:

Before you operate the system, complete the preparation procedures.

Switching the system on

- Press **POWER** (⏻ on the remote control).
→ The system will switch to the last selected source.
- Press **SOURCE** (CD, TUNER or AUX on the remote control).
→ The system will switch to the selected source.

To switch the system to standby mode

- Press **POWER** (⏻ on the remote control).
→ The volume level (up to maximum volume level of 20), interactive sound settings, last selected source will be retained in the player's memory.

Power-saving automatic standby

The power-saving feature automatically switches to standby 15 minutes after a CD playback has ended and no control is operated.

Adjusting volume and sound

- 1 Press **VOLUME - / +** to increase or decrease volume.
→ Display shows the volume level and a number from 0-32.

- 2 Press **DBB** (on the remote control) to switch bass enhancement on or off.
→ Display shows: **DBB** if the DBB is activated.

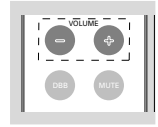

- 3 Press **MUTE** on the remote control to stop sound play-back instantly.
→ Playback will continue without sound and the display shows **MUTE**.

- To start sound playback you can:
 - press **MUTE** again;
 - adjust the volume controls;
 - change source.

CD Operation

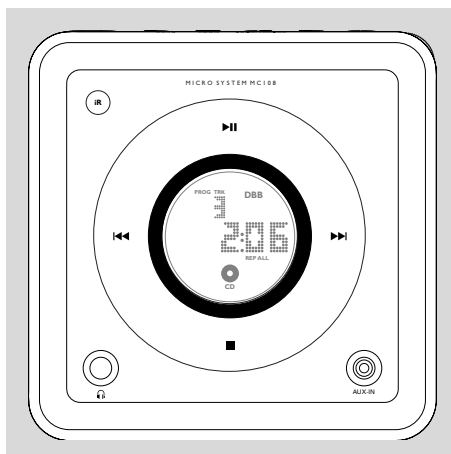

IMPORTANT:

The lens of the CD player should never be touched.

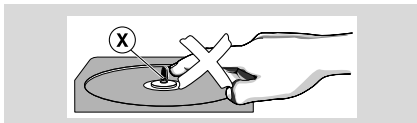

Playing a disc

This CD player plays Audio Discs including CD-Recordables and CD-Rewritables.

- CD-ROM, CD-I, CDV, VCD, DVD or computer CDs, however, are not possible.

1 Select **CD** source.

2 Press **OPEN•CLOSE** on the top of the system to open the CD compartment.

→ **OPEN** is displayed when you open the CD compartment.

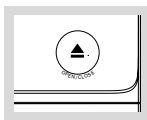

3 Insert a disc with the printed side facing up and press down on **OPEN•CLOSE** to close the CD door.

→ **TRK** is displayed as the CD player scans the contents of a disc. The total number of tracks and time are also shown.

4 Press **▶||** to start playback.

→ Current track number followed by elapsed playing time of the track are displayed during disc playback.

5 To pause playback press **▶||**. Press **▶||** again to resume play.

→ The display freezes and the current track number flashes when playback is paused.

6 To stop disc playback, press **■**.

Note: CD play will also stop when;

- the CD door is opened.
- the disc has reached the end.
- you select another source: **AUX, TUNER**.
- you select standby.

Selecting a different track

- Press **◀◀** or **▶▶** once or repeatedly until the desired track number appears in the display.
- If you have selected a track number shortly after loading a disc, or in the **PAUSE** position, you will need to press **▶||** to start playback.

Finding a passage within a track

1 Press and hold down **◀◀** or **▶▶**.

→ The disc is played at high speed and low volume.

2 When you find the passage you want, release **◀◀** or **▶▶**.

→ Normal playback continues.

Different play modes: SHUFFLE and REPEAT

You can select and change the various play modes before or during playback.

REPEAT plays the current track continuously

REPEAT ALL ... repeats the entire disc/ programme

SHUFFLE tracks of the entire disc are played in random order

- 1** To select your play mode, press **SHUFF** or **REPEAT** on the remote control before or during playback until the display shows the desired function.
- 2** Press **▶II** to start playback if in the STOP position.
→ If you have selected SHUFFLE, playback starts automatically.
- 3** To return to normal playback, press **SHUFF** or **REPEAT** on the remote control until the various SHUFFLE/ REPEAT modes are no longer displayed.
- You can also press **STOP ■** to cancel your play mode..

Programming track numbers

Programme in the STOP position to select and store your disc tracks in the desired sequence. If you like, store any track more than once. Up to 20 tracks can be stored in the memory.

- 1** Press **◀◀** or **▶▶** to select your desired track number.
- 2** Press **PROG**.
→ Display shows: the selected track number.
PROG flashes and **PF** appears briefly.
- 3** Repeat steps **1-2** to select and store all desired tracks.
→ **FULL** is displayed if you attempt to programme more than 20 tracks.
- 4** To start playback of your disc programme, press **▶II**.

Notes:

- *If you wish, you can add further tracks to your current program. Make sure you are in the STOP position, and that you have not exceeded 20 tracks.*
- *Display shows **NOSE** if there is no track selected.*

Erasing the programme

You can erase the programme by:

- pressing **■** once in the STOP mode;
- pressing **■** twice during playback;
- opening the CD compartment;
- Select another sound source
→ **PROG** disappears from the display.

Radio Reception

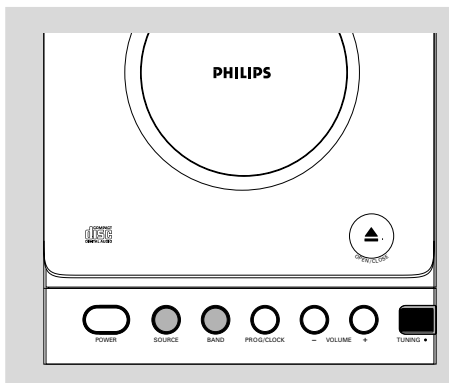

- 3 Turn **TUNING** ● to tune to a station.
→ Display shows: the frequency of the tuned station.

Helpful hints:

To improve radio reception:

- For **FM**, extend coil antenna at the back of the unit fully for optimum reception.

Tuning to radio stations

- 1 Select **TUNER** source.
→  is displayed.
- 2 Press **BAND (TUNER** on the remote control) once or more to select your waveband.

Maintenance

Cleaning the Cabinet

- Use a soft cloth slightly moistened with a mild detergent solution. Do not use a solution containing alcohol, spirits, ammonia or abrasives.

Cleaning Discs

- When a disc becomes dirty, clean it with a cleaning cloth. Wipe the disc from the centre out.
- Do not use solvents such as benzene, thinner; commercially available cleaners, or antistatic spray intended for analogue records.



Cleaning the disc lens

- After prolonged use, dirt or dust may accumulate at the disc lens. To ensure good playback quality, clean the disc lens with Philips CD Lens Cleaner or any commercially available cleaner. Follow the instructions supplied with cleaner.

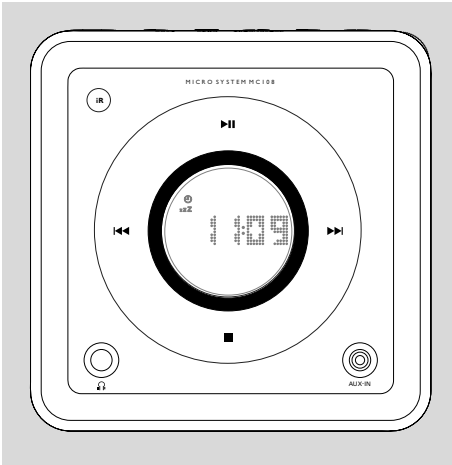

Setting the clock

- 1 In Standby mode, press **PROG/CLOCK** button.
→ The clock digits for the hours flash.
- 2 Press **◀◀ / ▶▶** to set the hours.
- 3 Press **PROG/CLOCK** again.
→ The clock digits for the minutes flash.
- 4 Press **◀◀ / ▶▶** to set the minutes.
- 5 Press **PROG/CLOCK** to confirm the time.

Note:

– If the clock has not been set, --:-- will be displayed.

Setting the timer

- The system can be used as an alarm clock. CD or TUNER can be set to switch on at a preset time. The clock time needs to be set first before the timer can be used.
- If no button is pressed within 90 seconds during timer setup, the system will exit timer setting mode automatically.

- 1 In any mode, press **TIMER** (on the remote control) for more than 2 seconds.
- 2 Press **◀◀ / ▶▶** (or **CD / TUNER** on the remote control) to select sound source.
- 3 Press **TIMER** to confirm your desired source.
→ The clock digits for the hours flash.
- 4 Press **◀◀ / ▶▶** to set the hours.
- 5 Press **TIMER** again.
→ The clock digits for the minutes flash.
- 6 Press **◀◀ / ▶▶** to set the minutes.
- 7 Press **TIMER** to confirm the time.
→ The timer is now set and actiated.

Notes:

- If source CD is selected and no disc is in the CD tray or the disc has an error, TUNER will be selected automatically.

- The volume level will be increased from min. to 20 within 2 minutes after alarm wake up.

Activating and deactivating TIMER

- In standby or during playback, press **TIMER** once.
→ Display shows  if activated, and disappears if deactivated.

Activating and deactivating SLEEP

The sleep timer enables the system to switch off by itself after a set period of time. The clock time needs to be set first before the sleep timer can be used.

- Press **SLEEP** on the remote control repeatedly to select desired time before system shuts off.

→ Display shows **SLEEP** and series of time options for selection: **60** , **45** , **30** , **15** , **0** , **60** ...

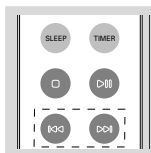

- To deactivate, press **SLEEP** on the remote control once or more until “ ” is shown, or press **STANDBY ON** on the system or remote control.

Specifications

AMPLIFIER

Output power 2 x 2 W RMS
..... 4 W + 4 W MPO
Signal-to-noise ratio ≥ 62 dBA (IEC)
Frequency response 60 – 16000 Hz, ± 3 dB
Impedance loudspeakers 8 Ω
Impedance headphones 32 Ω – 1000 Ω

CD PLAYER

Frequency range 20 – 20000 Hz
Signal-to-noise ratio 75 dBA

TUNER

FM wave range 87.5 – 108 MHz
MW wave range 531 – 1602 kHz
Sensitivity at 75 Ω
– mono, 26 dB signal-to-noise ratio 2.8 μV
– stereo, 46 dB signal-to-noise ratio 61.4 μV
Selectivity ≥ 28 dB
Total harmonic distortion ≤ 5%
Frequency response 63 – 12500 Hz (± 3 dB)
Signal-to-noise-ratio ≥ 50 dB

SPEAKERS

Bass reflex system
Dimensions (w x h x d) . 150 x 150 x 200 (mm)

GENERAL INFORMATION

AC Power 220 – 230 V / 50 Hz
Dimensions (w x h x d) .. 150 x 150 x 220 (mm)
Weight (with/without speakers)
..... approx. 4.9 / 2.3 kg
Standby power consumption < 3 W

Subject to modification

WARNING

Under no circumstances should you try to repair the system yourself, as this will invalidate the warranty. Do not open the system as there is a risk of electric shock.

If a fault occurs, first check the points listed below before taking the system for repair. If you are unable to remedy a problem by following these hints, consult your dealer or service centre.

Problem	Solution
CD OPERATION	
"no cd" is displayed.	<ul style="list-style-type: none"> – Insert a disc. – Check if the disc is inserted upside down. – Wait until the moisture condensation at the lens has cleared. – Replace or clean the disc, see "Maintenance". – Use a finalised CD-RW or CD-R.
RADIO RECEPTION	
Radio reception is poor.	<ul style="list-style-type: none"> – If the signal is too weak, adjust the antenna or connect an external antenna for better reception. – Increase the distance between the Micro HiFi System and your TV or VCR.
GENERAL	
The system does not react when buttons are pressed.	<ul style="list-style-type: none"> – Remove and reconnect the AC power plug and switch on the system again.
Sound cannot be heard or is of poor quality.	<ul style="list-style-type: none"> – Adjust the volume. – Disconnect the headphones. – Check that the speakers are connected correctly. – Check if the stripped speaker wire is clamped.
The left and right sound outputs are reversed.	<ul style="list-style-type: none"> – Check the speaker connections and location.
The remote control does not function properly.	<ul style="list-style-type: none"> – Select the source (CD or TUNER, for example) before pressing the function button (▶, ◀, ▶). – Reduce the distance between the remote control and the system. – Insert the batteries with their polarities (+/- signs) aligned as indicated. – Replace the batteries. – Point the remote control directly toward IR sensor on the front of the system.
The timer is not working.	<ul style="list-style-type: none"> – Set the clock correctly. – Press TIMER to switch on the timer. – If a recording is in progress, stop the recording.
The Clock/Timer setting is erased.	<ul style="list-style-type: none"> – Power has been interrupted or the power cord has been disconnected. Reset the clock/timer.

Meet Philips at the Internet
<http://www.philips.com>

English

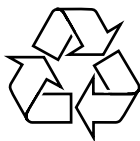

MC108

