

Register your product and get support at
www.philips.com/welcome

User manual



PHILIPS

1

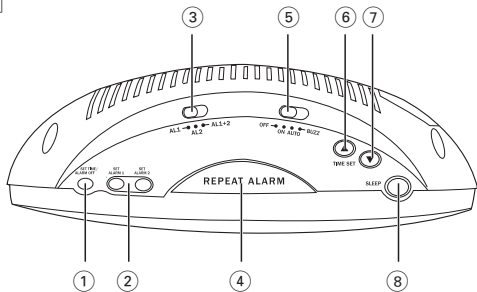

2

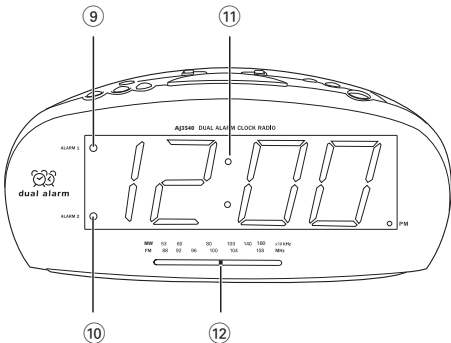

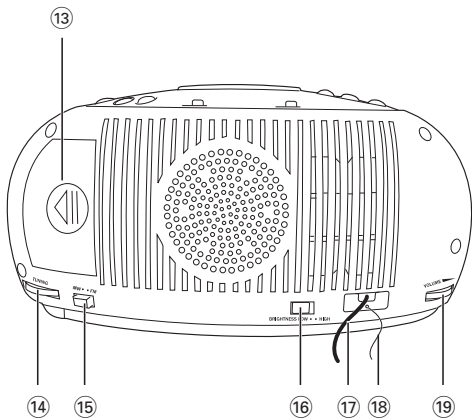

English

Congratulations on your purchase and welcome to Philips!

To fully benefit from the support that Philips offers, register your product at www.philips.com/welcome.

CONTROLS

Top View (see fig. )

① **SET TIME /ALARM OFF**

- sets the clock time
- stops the active alarm for 24 hours
- switches off the radio sleep function

② **SET ALARM 1 / SET ALARM 2** - sets the alarm time for alarm 1 / alarm 2

③ **AL1/ AL2 /AL1+2** - selects which alarm(s) you want to set alarm time on

④ **REPEAT ALARM** - switches off the active alarm for a 7-8 minutes period

⑤ **OFF/ ON/ AUTO/ BUZZ**

OFF: switches off the radio/alarm

ON: switches on the radio

AUTO: activates the radio for alarm

BUZZ: activates the buzzer for alarm

⑥ **TIME SET ▲** - to adjust time fast forward

⑦ **TIME SET ▼** - to adjust time back

⑧ **SLEEP**

- activates the radio for sleep function
- adjusts the sleep period

Front View (see fig. )

⑨ **ALARM 1** indicator - lights up when alarm 1 is activated.

⑩ **ALARM 2** indicator - lights up when alarm 2 is activated.

⑪ **DISPLAY** - shows the clock/alarm time and status of the setting

⑫ **Frequency** pointer - shows the radio frequency of your selected waveband

Back View (see fig. 3)

- ⑬ **Battery door** - opens to store a **9 volts 6F22** battery (not included) for clock memory backup.
- ⑭ **TUNING** - tunes to radio stations
- ⑮ **FM/MW** - selects FM/MW waveband
- ⑯ **BRIGHTNESS (High or Low)** -selects display brightness
- ⑰ **Power cord** - connects to wall outlet
- ⑱ **Pigtail** - improve FM reception
- ⑲ **VOLUME** - adjusts the sound level

INSTALLATION

POWER SUPPLY

- 1** Check if the power supply, as shown on the **type plate located on the bottom of the set**, corresponds to your local power supply. If it does not, consult your dealer or service center.
- 2** Connect the power cord to the wall outlet.
- 3 To disconnect the set from the power supply completely, remove the plug from the wall outlet.**

SELECTING DISPLAY BRIGHTNESS

This set allows you to choose high or low brightness of display.

- Adjust **BRIGHTNESS** switch (located on the rear of the set) to **HIGH** or **LOW** position.

CLOCK MEMORY BACKUP

The clock memory backup allows your alarm and clock time settings to be stored for up to a day when there is a power interruption e.g. power failure. The complete clock radio and display illumination will be switched off. As soon as the power supply returns, the display will indicate the correct time.

- 1 Remove the battery door to insert a **9 volts 6F22** type battery (not included) for backup.
- 2 Close the battery door.

NOTE: *If no backup battery is installed or the power interruption is prolonged, you will need to set the clock and alarm times again.*

Batteries contain chemical substances so they should be disposed of properly.

Standby power consumption2W

RADIO

You can use this set solely as a radio!

- 1 Adjust **OFF/ ON/ AUTO/ BUZZ** to **ON** to switch on the radio.
- 2 Select your waveband by adjusting the **FM/MW** switch.
- 3 Adjust **TUNING** to tune to your desired station.
- 4 Turn the **VOLUME** control to adjust the volume level.
- 5 Adjust **OFF/ ON/ AUTO/ BUZZ** to **OFF** to switch off the radio.

To improve reception:

- FM:** Extend and position the pigtail fully to obtain optimal reception.
- MW:** uses a built-in antenna inside the set. Direct the antenna by adjusting the position of your set.

SETTING THE CLOCK TIME

The time is displayed using the 12-hour clock.

- 1 Hold down **SET TIME/ALARM OFF**.
 - 2 Press **TIME SET ▲** or **▼** repeatedly, or hold down **TIME SET ▲** or **▼** to adjust minute and/or hour.
 - **TIME SET ▲** : to adjust time fast forward
 - **TIME SET ▼** : to adjust time back
 - 3 Release **SET TIME/ALARM OFF** and **TIME SET ▲** or **▼** when you reach the correct setting.
- The set clock time will show on the display and start to run.

USING THE ALARM

This set allows you to set one alarm (alarm 1 or alarm 2), or set two alarms simultaneously. This set also offers you two alarm modes: Auto (radio) and Buzz.

SETTING THE ALARM TIME

- 1 Hold down **SET ALARM 1** or **SET ALARM 2**
- 2 Press **TIME SET ▲** or **▼** repeatedly, or hold down **TIME SET ▲** or **▼** to adjust minute and/or hour.
- 3 Release **SET ALARM 1** or **SET ALARM 2**, and **TIME SET ▲** or **▼** when you reach the desired time setting. The display will return to the clock time.

SELECTING THE ALARM MODE

- 1 Adjust **AL1/AL2/AL1+2** to **AL1** (alarm 1), or **AL2** (alarm 2), or **AL1+2** (alarm 1 + alarm 2).
- 2 Select your choice of alarm mode by adjusting **OFF/ ON/ AUTO/ BUZZ** to **AUTO** or **BUZZ**.
 - The corresponding alarm indicator(s) will light up.

Helpful Hint:

- If you have selected the radio mode, make sure you have adjusted the volume loud enough to wake you.
- The buzzer is set at a fixed volume and cannot be adjusted.

SWITCHING OFF THE ALARM

There are three ways of switching off the alarm. Unless you cancel the alarm completely, the **24 hour alarm reset option** will be automatically selected after 59 minutes, from the time your alarm time first goes off.

24 HOUR ALARM RESET

If you want the alarm mode to be stopped immediately but also wish to retain the same alarm setting for the following day:

- Press **SET TIME/ALARM OFF** during the alarm call.

CANCELING THE ALARM COMPLETELY

To cancel the set alarm time before it goes off, or during the alarm call:

- Adjust **OFF/ON/AUTO/BUZZ** to **OFF** position.

REPEAT ALARM

This repeats your alarm call at 7-8-minute intervals.

- 1** During the alarm call, press **REPEAT ALARM**.
- 2** Repeat if desired for up to 59 minutes.

SLEEP

This set has a built-in timer which enables the set to be automatically switched off during radio playback after a set period of time. This allows you to lie back, listen and fall asleep. The maximum sleep time is 59 minutes.

Setting SLEEP

- 1** Set **OFF/ON/AUTO/BUZZ** to **OFF** position.
- 2** Set your sleep time by pressing on the **SLEEP** button. Keep your finger on the button and the display will begin to count down from 0:59 to 0:00 minute.
 - To cancel sleep, press **SET TIME/ALARM OFF**.
 - To view the remaining sleep time, press **SLEEP**.

TROUBLESHOOTING

If a fault occurs, first check the points listed below before taking the set for repair. If you are unable to remedy a problem by following these hints, consult your dealer or service center:

WARNING: *Under no circumstances should you try to repair the set yourself, as this will invalidate the warranty. Do not open the set as there is a risk of electric shock.*

Problem

- Possible Cause
- Remedy

No sound/power

- Volume not adjusted
- Adjust the volume

Occasional crackling sound during FM broadcast

- Weak signal
- Adjust the position of the Pigtail

Continuous crackling/hiss disturbance during MW broadcast

- Electrical interference from TV, computer, fluorescent lamp, etc.
- Move set away from other electrical equipment

The alarm does not function

- Alarm time not set and or alarm mode not selected
- Set the alarm time and / select alarm mode
- Volume too low for RADIO
- Adjust the volume
- Radio alarm not adjusted to radio station
- Tune to a radio station

SAFETY INFORMATION

- Place the set on a hard and flat surface so that the system does not tilt.
- Where the MAINS plug or an appliance coupler is used as the disconnet device, the disconnet device shall remain readily operable.
- If you do not intend to use the set for a long time, withdraw the power plug from the wall outlet. In addition to this, it is advisable to remove the battery from the clock radio. This will prevent any danger of leakage and the clock radio will not be damaged.
- Do not expose the set, batteries to humidity, rain, sand or excessive heat caused by heating equipment or direct sunlight.
- The apparatus shall not be exposed to dripping or splashing.
- Adequate ventilation with a minimum gap of 15cm between the ventilation holes and surrounding surfaces is necessary to prevent heat build-up.
- The ventilation should not be impeded by covering the ventilation openings with items, such as newspapers, table-cloths, curtains, etc..
- No objects filled with liquids, such as vases, shall be placed on the appartus.
- No naked flame sources, such as lighted candles, should be placed on the apparatus.
- To clean the set, use a soft, slightly dampened chamois leather. Do not use any cleaning agents containing alcohol, ammonia, benzene or abrasives as these may harm the housing.

CAUTION

Use of controls or adjustments or performance of procedures other than herein may result in unsafe operation.

ENVIRONMENTAL INFORMATION

We have reduced packaging to the minimum for easy separation into two materials: paper and cardboard.

Your set consists of materials which can be recycled if disassembled by a specialized company. Please observe local regulations on the disposal of packing materials and old equipment.

PHILIPS

Model No.: AJ3540/96
110-127V ~ 60Hz 5W
Made in China



R33048-ETC

Meet Philips at the Internet
<http://www.philips.com>

AJ3540

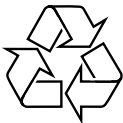

Printed in China

AJ3540_96_UM_V1.0