

QUICK START INÍCIO RÁPIDO

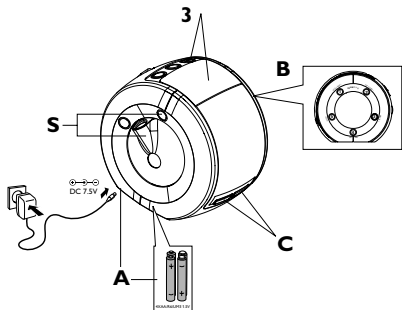

Thanks for buying **Philips AJ3600 clock radio**.
Our **Quick Start** guides you through just some of the features on the set.
Please read our instruction booklet to really rise & shine!

PHILIPS



ENGLISH

Quick start as easy as ABC!

Step A

- Connect the supplied mains adapter to the set's 7.5V DC jack and the plug into a wall outlet **or** insert 4 batteries into the battery compartment.

Step B

How to set the Clock & Alarm times

1. Check the radio is switched off.
2. Press and hold **SET TIME/SET ALARM 1/SET ALARM 2**.
3. Press and hold **HOUR+/MINUTE+**.
4. Press **SET TIME/SET ALARM 1/SET ALARM 2**.

Step C

Selecting the Alarm mode

Press briefly:

- **AL1** once for radio 🎵
- or /and
- **AL2** once for buzzer 🔔

Helpful hints:

- If you have selected AL1 (AL 🎵), make sure you have properly tuned to a station before turning off the set (See **TUNING TO RADIO STATIONS** in the user manual).

3 ways to switch off the alarm

- Either press briefly: **ALARM RESET/SLEEP** or **REPEAT ALARM/**
BRIGHTNESS CONTROL
- Press **AL1** or **AL2**.

Special feature:(See S)

Projection (Optimum:Within 2.5m)

With this projection feature, you can conveniently project the clock time onto a surface e.g. walls, ceiling.

1. Press **PROJECTION ON/OFF** to switch on.
2. Turn the **Projection lens wheel** (maximum 180° left or right) and also the set, if necessary, to find a suitable projection surface.

Helpful hints:

- For longer projection time, please use the supplied 7.5V AC adapter to operate the set.