

# Always there to help you

Register your product and get support at  
[www.philips.com/support](http://www.philips.com/support)

NTX800



## User manual

# PHILIPS



# Contents

<b>1 Important</b>	2
Safety	2
<b>2 Your Mini Hi-Fi System</b>	4
Introduction	4
What's in the box	4
Overview of the main unit	5
Overview of the remote control	7
<b>3 Get started</b>	8
Prepare the remote control	8
Connect	8
Turn on	10
Turn demo mode on or off	10
<b>4 Play</b>	11
Play from a disc or USB	11
Play audio through Bluetooth	13
Play from an external device	14
<b>5 Listen to radio</b>	15
Tune to a radio station	15
Program radio stations automatically	15
Program radio stations manually	15
Select a preset radio station	15
Change AM tuning grid	15
<b>6 Adjust volume level and sound effect</b>	16
Adjust volume level	16
Mute sound	16
Apply AUTO DJ effect	16
Apply DJ effects manually	16
Select a preset sound effect	16
Enhance bass	16
Apply NX Bass effect	17
Adjust equalizer settings	17
<b>7 Other features</b>	18
Mix sound	18
Speak or sing with a microphone	18
Turn the decorative light on or off	18
Reverse the display	18
Listen through a headphone	18
<b>8 Product information</b>	19
Specifications	19
USB playability information	20
Supported MP3 disc formats	20
Maintenance	20
<b>9 Troubleshooting</b>	21
General	21
About Bluetooth device	22
<b>10 Notice</b>	23
Care of the environment	23
Trademark notice	23

# 1 Important

## Safety

### Know these safety symbols



This 'bolt of lightning' indicates uninsulated material within your unit may cause an electrical shock. For the safety of everyone in your household, please do not remove product covering.

The 'exclamation point' calls attention to features for which you should read the enclosed literature closely to prevent operating and maintenance problems.

**WARNING:** To reduce the risk of fire or electric shock, this apparatus should not be exposed to rain or moisture and objects filled with liquids, such as vases, should not be placed on this apparatus.

**CAUTION:** To prevent electric shock, match wide blade of plug to wide slot, fully insert.

### Warning

- Never remove the casing of this device.
- Never lubricate any part of this device.
- Never place this device on other electrical equipment.
- Keep this device away from direct sunlight, naked flames or heat.
- Never look into the laser beam inside this device.
- Ensure that you always have easy access to the power cord, plug, or adaptor to disconnect this device from the power.

- Do not use this apparatus near water.
- Install in accordance with the manufacturer's instructions.

- Do not install near any heat sources such as radiators, heat registers, stoves, or other apparatus (including amplifiers) that produce heat.
- Protect the power cord from being walked on or pinched, particularly at plugs, convenience receptacles, and the point where they exit from the apparatus.
- Only use attachments/accessories specified by the manufacturer.
- Use only with the cart, stand, tripod, bracket, or table specified by the manufacturer or sold with the apparatus. When a cart is used, use caution when moving the cart/apparatus combination to avoid injury from tip-over.



- Unplug this apparatus during lightning storms or when unused for long periods of time.
- Refer all servicing to qualified service personnel. Servicing is required when the apparatus has been damaged in any way, such as power-supply cord or plug is damaged, liquid has been spilled or objects have fallen into the apparatus, the apparatus has been exposed to rain or moisture, does not operate normally, or has been dropped.
- Battery usage **CAUTION** – To prevent battery leakage which may result in bodily injury, property damage, or damage to the remote control:
  - Install all batteries correctly, + and - as marked on the remote control.
  - Do not mix batteries (old and new or carbon and alkaline, etc.).
  - Remove batteries when the remote control is not used for a long time.
- Batteries (battery pack or batteries installed) shall not be exposed to excessive heat such as sunshine, fire or the like.

- Apparatus shall not be exposed to dripping or splashing.
- Do not place any sources of danger on the apparatus (e.g. liquid filled objects, lighted candles).
- Where the MAINS plug or an appliance coupler is used as the disconnect device, the disconnect device shall remain readily operable.

**!** **Caution**

- Use of any controls, adjustments, or procedures other than those specified herein may result in hazardous laser exposure or other unsafe operation.

## Hearing safety



### Listen at a moderate volume.

- Using headphones at a high volume can impair your hearing. This product can produce sounds in decibel ranges that may cause hearing loss for a normal person, even for exposure less than a minute. The higher decibel ranges are offered for those that may have already experienced some hearing loss.
- Sound can be deceiving. Over time your hearing 'comfort level' adapts to higher volumes of sound. So after prolonged listening, what sounds 'normal' can actually be loud and harmful to your hearing. To guard against this, set your volume to a safe level before your hearing adapts and leave it there.

### To establish a safe volume level:

- Set your volume control at a low setting.
- Slowly increase the sound until you can hear it comfortably and clearly, without distortion.

### Listen for reasonable periods of time:

- Prolonged exposure to sound, even at normally 'safe' levels, can also cause hearing loss.
- Be sure to use your equipment reasonably and take appropriate breaks.

### Be sure to observe the following guidelines when using your headphones.

- Listen at reasonable volumes for reasonable periods of time.
- Be careful not to adjust the volume as your hearing adapts.
- Do not turn up the volume so high that you can't hear what's around you.
- You should use caution or temporarily discontinue use in potentially hazardous situations.

**≡** **Note**

- The type plate is located on the back of the unit.

## 2 Your Mini Hi-Fi System

Congratulations on your purchase, and welcome to Philips! To fully benefit from the support that Philips offers, register your product at [www.Philips.com/welcome](http://www.Philips.com/welcome).

---

### Introduction

#### With this product, you can

- enjoy audio from discs, USB storage devices, Bluetooth enabled devices, or other external devices;
- swap play between the dual audio sources with the cross fader;
- listen to FM or AM radio stations;
- speak or sing with microphones through the loudspeakers of the unit; and
- record to a USB storage device.

#### To enrich sound, this unit offers you these sound effects:

- Preset equalizer (EQ) settings
- Dynamic Bass Boost (DBB)
- DJ effects
- NX Bass Enhancement

---

### What's in the box

Check and identify the following box contents:

- Main unit x 1
- Speaker box x 1
- Remote control with 2 AAA batteries
- FM wire antenna x 1
- AM loop antenna x 1
- Short user manual

## Overview of the main unit

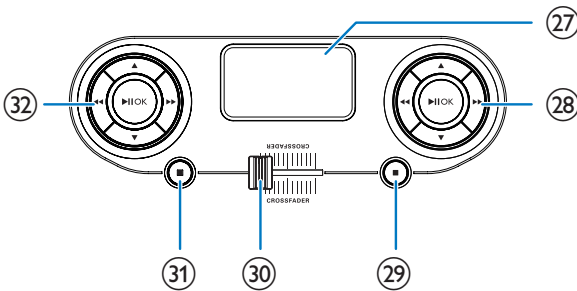
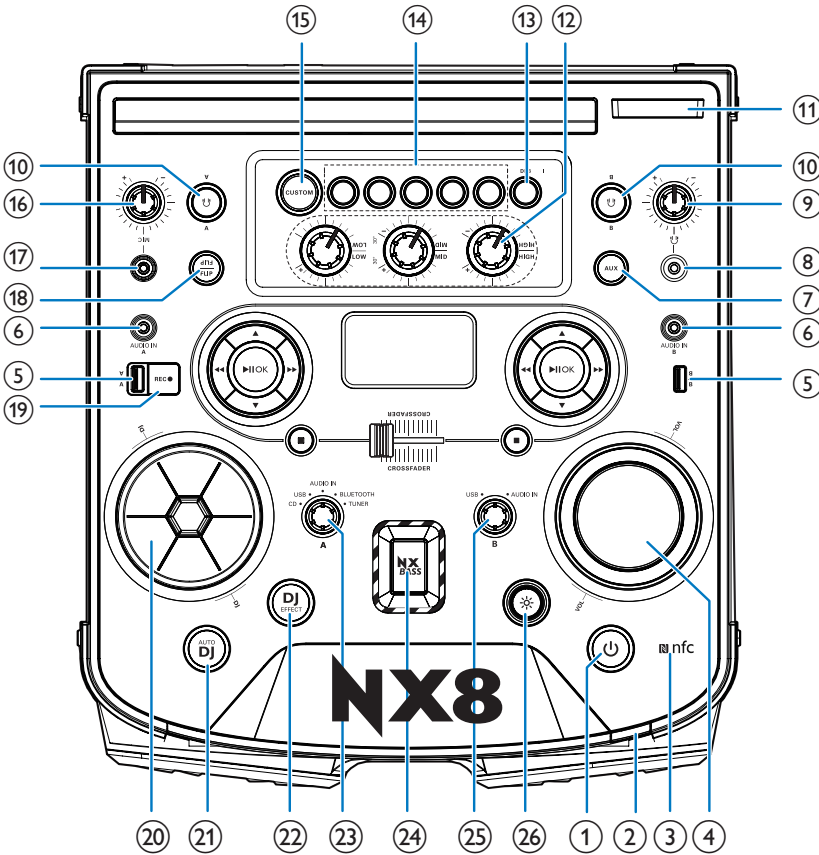

①

- Turn on the unit or switch to standby mode.

②

- Open or close the disc tray.

- ③ **NFC**
  - Connect a NFC compatible device through Bluetooth.
- ④ **Volume knob**
  - Adjust volume.
- ⑤ **USB A/B socket**
  - Connect USB mass storage devices.
- ⑥ **AUDIO IN A/B socket**
  - Connect an external audio device.
- ⑦ **AUX**
  - Select an audio source from an external device: DVD, PC, TV or GAME player.
- ⑧ **Headphone socket**
  - Connect a headphone.
- ⑨ **🔊 knob**
  - Adjust the headphone volume.
- ⑩ **🔊 A/B**
  - Listen from Source A/B through a headphone.
- ⑪ **Bluetooth indicator**
  - Show Bluetooth connection status.
- ⑫ **Custom Equalizer knobs**
  - Adjust the equalizer settings for high/middle/low frequency ranges.
- ⑬ **DBB**
  - Turn dynamic bass enhancement on or off.
- ⑭ **Sound effect keys**
  - Select a preset sound effect.
- ⑮ **Custom**
  - Activate custom equalizer effect.
- ⑯ **MIC knob**
  - Adjust microphone volume.
- ⑰ **MIC socket**
  - Connect a microphone.
- ⑱ **FLIP**
  - Reverse the display.
- ⑲ **REC**
  - In USB A mode, record to a USB device.
- ⑳ **DJ EFFECT dial**
  - Adjust the sound level of DJ effects.
- ㉑ **AUTO DJ**
  - In USB A mode, apply AUTO DJ effects automatically.
- ㉒ **DJ EFFECT**
  - In CD, USB A, Bluetooth, Tuner, or Audio in A mode, apply DJ effects manually.
- ㉓ **Source selector A**
  - Select an audio source: CD, USB A, Bluetooth, Tuner, or Audio in A.
- ㉔ **NX Bass**
  - Turn on NX Bass effect.
- ㉕ **Source selector B**
  - Select an audio source: USB B or AUDIO IN B.
- ㉖ **☼**
  - Enable or disable the speaker lighting effect.
  - Turn demo mode on or off.
- ㉗ **Display panel**
  - Show current status.
- ㉘ **Control play panel (B)**
  - Control play for **Source B** modes (including USB B mode and Audio in B mode).
- ㉙ **■ (B)**
  - In USB B mode, stop play.
- ㉚ **CROSS FADER**
  - Adjust the channel balance between Source A and Source B during playback.
- ㉛ **■ (A)**
  - In Disc or USB A mode, stop play.
  - In Disc or USB A mode, erase programmed list.
  - Exit the recording process.
  - In tuner mode, switch between FM and AM bands.



- 32) **Control play panel (A)**
- Control play for Source A modes (including CD, USB A, Bluetooth, Tuner, and Audio in A modes).

## Overview of the remote control

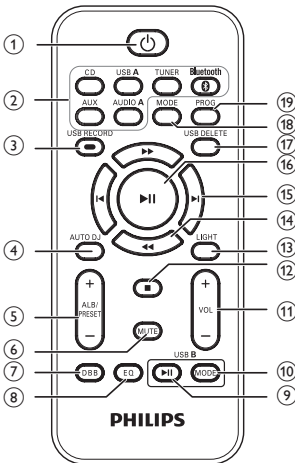

- 1) **Power**
- Turn on the unit or switch to standby mode.
- 2) **Source selection keys**
- Select an audio source.
- 3) **USB RECORD**
- In USB A mode, record to a USB device.
- 4) **AUTO DJ**
- In USB A mode, apply AUTO DJ effect automatically.
- 5) **ALB/PRESET +/-**
- In Disc or USB A mode, skip to the previous or next album.
  - In tuner mode, select a preset radio station.
- 6) **MUTE**
- Mute or resume sound.

- 7) **DBB**
- Turn dynamic bass enhancement on or off.
- 8) **EQ**
- Select a preset equalizer (EQ) setting.
- 9) **USB B ►►**
- In USB B mode, start or pause play.
- 10) **USB B MODE**
- In USB B mode, repeat or shuffle play.
- 11) **VOL +/-**
- Adjust volume.
- 12) **■**
- In Disc or USB A mode, stop play.
  - In Disc or USB A mode, erase programmed list.
  - Exit the recording process.
- 13) **LIGHT**
- Enable or disable the speaker lighting effect.
- 14) **◀◀ / ▶▶**
- In tuner mode, tune to radio stations.
  - In Disc or USB A mode, search within a track.
- 15) **◀ / ▶**
- In Disc, USB A, or Bluetooth mode, skip to the previous or next track.
- 16) **►►**
- In Disc, USB A, or Bluetooth mode, start or pause play.
- 17) **USB DELETE**
- In USB A mode, delete audio files stored on a USB storage device.
- 18) **MODE**
- In Disc or USB A mode, select a repeat play mode.
  - In Disc or USB A mode, play tracks randomly.
- 19) **PROG**
- In Disc or USB A mode, program tracks.
  - In tuner mode, program radio stations.

# 3 Get started

## ! Caution

- Use of controls or adjustments or performance of procedures other than herein may result in hazardous laser exposure or other unsafe operation.

Always follow the instructions in this chapter in sequence.

If you contact Philips, you will be asked for the model and serial number of this apparatus. The model number and serial number are on the back of the apparatus. Write the numbers here:  
Model No. \_\_\_\_\_  
Serial No. \_\_\_\_\_

## Prepare the remote control

### ≡ Note

- Danger of explosion if batteries are incorrectly replaced. Replace only with the same or equivalent type.
- Batteries contain chemical substances, so they should be disposed of properly.

- 1 Open the battery compartment.
- 2 Insert two AAA batteries with correct polarity (+/-) as indicated.
- 3 Close the battery compartment.

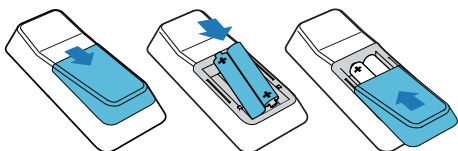

## Connect

### Connect FM antenna

#### ≡ Note

- For better reception, fully extend and adjust the position of the FM antenna.

Connect the supplied FM antenna to the **FM** jack on the back of the main unit.

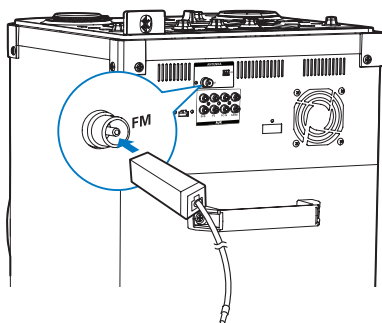

### Connect AM antenna

#### ≡ Note

- For better reception, adjust the position of the AM antenna.

- 1 Assemble the AM loop antenna.

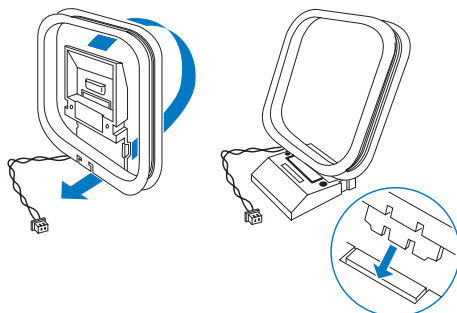

- 2 Connect the AM loop antenna to the AM jack on the back of the main unit.

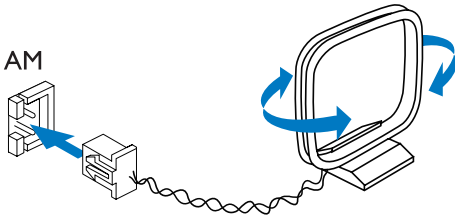

## Connect speaker

### Note

- For optimal sound, use the supplied speaker only.

Insert the speaker wire completely into the SPEAKER OUT sockets.

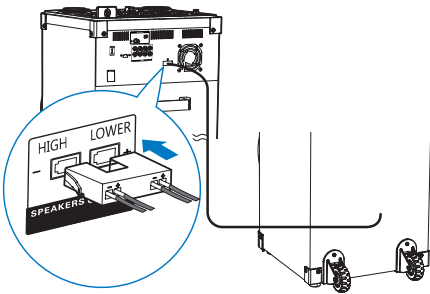

## Connect LED wire

- 1 Find the LED socket on the back of the main unit.
- 2 Insert the connector of the LED wire into the LED socket.

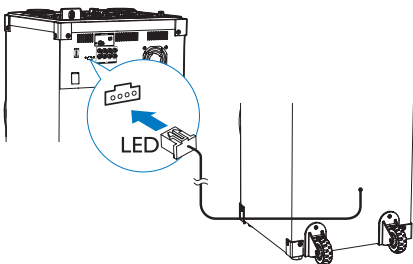

## Connect power

### Caution

- Risk of product damage! Make sure that you have selected the power supply voltage that corresponds to your local power supply.
- Risk of electric shock! When you unplug the power cord, always pull the plug from the socket. Never pull the cord.

### Note

- Before connecting to AC power, make sure that you have completed all other connections.

- 1 Adjust the voltage selector on the back of the main unit to match your local power supply.

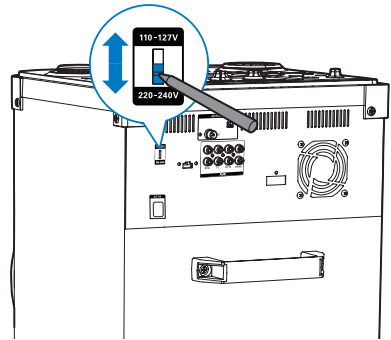

- 2 Connect the AC power plug to the power outlet.

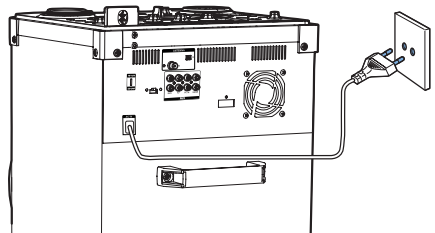

---

## Turn on

Press  $\phi$ .

- ↳ The unit switches to the last selected source.

---

## Switch to standby mode

Press  $\phi$  again to switch the unit to standby mode.

- ↳ The  $\phi$  button lights up red.

---

## Turn demo mode on or off

In standby mode, press and hold  $\ast$  for more than 5 seconds to turn demo mode on or off.

- ↳ When the demo mode is activated, the color of the speaker box changes randomly and constantly.

# 4 Play

## Play from a disc or USB

### Play disc

#### Note

- Make sure that the disc contains playable audio contents.

- 1 Slide **CROSS FADER** to the far left.

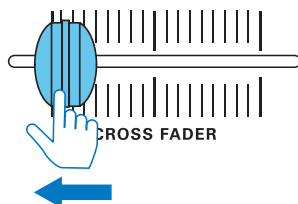

- 2 Press **CD** to select the disc source.
- 3 Press **▲** on the main unit to open the disc tray.
- 4 Load a disc on the disc tray, with the printed side facing up.

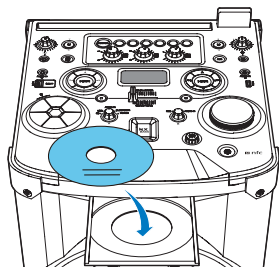

- 5 Press **▲** on the main unit to close the disc tray.
  - To start, pause, or resume play, press **▶||**.
  - To stop play, press **■**.
  - To select another track, press **◀** or **▶**.

- To select an album, press **ALB/PRESET+/-**.
- To search within a track, press and hold **◀◀** or **▶▶**, then release to resume normal play.

## Play from a USB A device

#### Note

- Make sure that the USB device contains playable audio contents in supported formats.

- 1 Slide **CROSS FADER** to the far left.
- 2 Insert the USB plug of the device into the **USB A** socket.

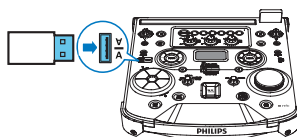

- 3 Press **USB A** to select the USB A source.
- 4 Press **ALB/PRESET+/-** to select an album.
- 5 Press **◀** or **▶** to select an audio file.
- 6 Press **▶||** to start play.
  - To pause or resume play, press **▶||**.
  - To stop play, press **■**.
  - To search within an audio file, press and hold **◀◀** or **▶▶**, then release to resume normal play.

### Delete from a USB device

- 1 In USB A mode, press **■** to stop music playback.
- 2 Press **◀** or **▶** to select an audio file.
  - To delete an audio folder, press **ALB/PRESET+/-** to select an audio folder; then press **◀** or **▶** to select a file.
- 3 Press **USB DELETE** repeatedly to select:
  - **[DEL FILE]** (Delete file): Delete current audio file.
  - **[DEL DIR]** (Delete directory): Delete current audio folder.
  - **[FORMAT]** (Format): Delete all files in the USB device.

- 4 Press ►|| to confirm the selection.
  - ↳ A confirmation message is displayed.
    - To cancel, press ■.

#### Note

- The function is not available in **USB B** mode.

#### Caution

- If [**FORMAT**] is selected, all files (including non-audio files) stored in the USB device will be erased.

### Record to a USB device

Audio CD tracks, MP3 files, radio, and audio from external devices are recorded in .mp3 format.

The first time you record to a USB device, a folder is automatically created on the USB device. Each time you record to a USB device, the recorded files are stored in a subfolder of this folder. Files and subfolders are named numerically in the order in which they are created.

- 1 Connect a USB device to ↔ A socket.
- 2 Prepare the source to record from.
  - Disc: Select the **CD** source and load a disc, then select a track to start recording.
  - Radio: Select the **TUNER** source, then tune to a radio station.
  - USB B: Select the **USB B** source, then connect and select an audio file to play.
- 3 Press **USB RECORD** to start recording.
  - For Disc mode, press **USB RECORD** repeatedly to select:
    - (A) [**REC ONE**] (record one): the first or current track is recorded.
    - (B) [**REC ALL**] (record all): all tracks or the remaining tracks are recorded.
  - ↳ Play starts automatically from the beginning of the disc or the selected track, and the recording starts.
    - To stop recording, press ■.

#### Note

- If the USB device does not have enough memory to store the audio files, a message about a full memory is displayed.
- This function is not available in "USB B" and "Mix sound" mode.
- This function is not available when **AUTO DJ** or **DJ EFFECT** effects are applied.

### Play from a USB B device

- 1 Slide **CROSS FADER** to the far right.
- 2 Rotate the source selector on the main unit to select the **USB B** source.
- 3 Insert the USB plug of the device into the **USB B** socket.
- 4 Use the control play panel (B) on the top panel of the main unit to control play.
  - To start, pause, or resume play, press ►||.
  - To select an album, press ▲ or ▼.
  - To select an audio file, press ◀◀ or ▶▶.
  - To stop play, press ■ (B).
  - To search within an audio file, press and hold ◀◀ or ▶▶, then release to resume normal play.

### Play options

#### Repeat and random play

- 1 In Disc/USB A mode, press **MODE** repeatedly (or in USB B mode, press **USB B MODE**) to select a play mode.
  - [**RPT ONE**] (repeat one): play the current track repeatedly.
  - [**RPT ALL**] (repeat all): play all tracks repeatedly.
  - [**RANDOM**] (random): play all tracks randomly.
- 2 To return to normal play, press **MODE** (or **USB B MODE**) repeatedly to select [**OFF**] (off).

## Note

- Shuffle play cannot be selected when you play the programmed tracks.

## Program tracks

You can program a maximum of 20 tracks.

- 1 In Disc or USB A mode, press **■** to stop playing.
- 2 Press **PROG** to activate the program mode.  
↳ A number flashes on the screen.
- 3 For MP3 tracks, press **ALB/PRESET +/-** to select an album.
- 4 Press **◀** or **▶** to select a track number; then press **PROG** to confirm selection.
- 5 Repeat steps 3 to 4 to program other tracks.
- 6 Press **▶||** to play the programmed track.
  - To erase the program, press **■** twice.

## Note

- The function is not available in **USB B** mode.

## Play audio through Bluetooth

The product can stream music from your Bluetooth device to the system through Bluetooth.

### Connect a device

## Note

- Before pairing a device with this product, read its user manual for Bluetooth compatibility.
- Make sure that Bluetooth function is enabled on your device, and your device is set as visible to all other Bluetooth devices.
- The operational range between this product and a Bluetooth device is approximately 10 meters (30 feet).
- Any obstacle between this product and a Bluetooth device can reduce the operational range. Keep away from any other electronic device that may cause interference.

### Option 1: Connect a device through NFC

Near Field Communication (NFC) is a technology that enables short-range wireless communication between various NFC compatible devices, such as mobile phones and IC tags.

If your Bluetooth device supports NFC, you can connect it with this speaker easily.

- 1 Enable NFC on your Bluetooth device (refer to its user manual).
- 2 Press **Bluetooth** to select BT source.  
↳ **[BT]** (BT) is displayed, then **[SEARCH]** (search) begins to flash.  
↳ The Bluetooth indicator flashes.
- 3 Tap the NFC tag on the top of the product with the NFC area of your Bluetooth device.

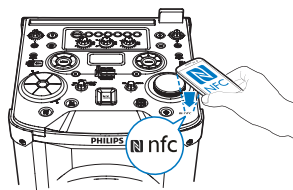

- 4 On your Bluetooth device, accept the pairing request with "PHILIPS NTX800".
- 5 Follow the on-screen instructions to complete the pairing and connection.  
↳ After successful connection, the Bluetooth indicator turns solid blue.

### Option 2: Connect a device manually

- 1 Slide **CROSS FADER** to the far left.
- 2 On your Bluetooth device, enable Bluetooth and search for Bluetooth devices that can be paired (see the user manual of the device).
- 3 Press **Bluetooth** repeatedly to select BT source.  
↳ **[BT]** (BT) is displayed, then **[SEARCH]** (search) begins to flash.  
↳ The Bluetooth indicator flashes.

- 4 Select **[PHILIPS NTX800]** displayed on your device for pairing. If necessary, input "0000" as the pairing password.
  - ↳ After successful connection, the Bluetooth indicator turns solid blue.

## Play from Bluetooth device

After successful Bluetooth connection, play audio on the Bluetooth device.

- ↳ Audio streams from your Bluetooth device to this product.

## Disconnect a device

- Disable Bluetooth on your device; or
- Move the device beyond the communication range.

### Note

- Before connecting another Bluetooth device, disconnect the current device first.

## Play from an external device

You can play audio from an external device through the speakers of this product.

## Play from an MP3 player

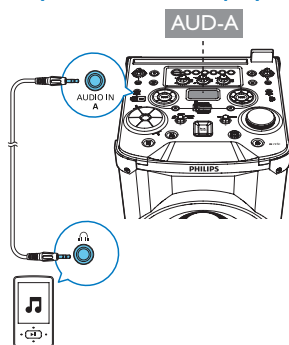

- 1 Slide **CROSS FADER** to the far left.
- 2 Press **AUDIO A** to select the **[AUD-A]** source.

- 3 Connect an audio input cable (not supplied) with a 3.5 mm connector on both ends to:
  - the **AUDIO IN A** socket on the unit, and
  - the headphone socket on the MP3 player.
- 4 Play audio on the MP3 player (refer to its user manual).

### Tip

- If the MP3 player is connected to the **AUDIO IN B** socket, rotate the source selector on the main unit to select the **[AUD-B]** source.

## Play from other audio device

You can connect a PC or other audio devices to this unit.

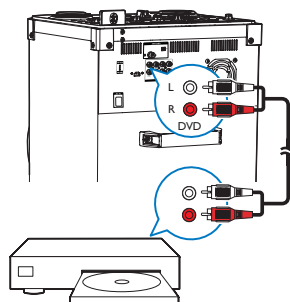

- 1 Press **AUX** repeatedly to cycle through **GAME, PC IN, TV** and **DVD** sources.
- 2 Connect the white and red audio cables (not supplied) to:
  - the **AUX** sockets on the back of the main unit, and
  - the headphone socket on a PC, or the **AUDIO OUT** socket on an external device.
- 3 Play audio on the device (refer to the user manual of the device).

### Tip

- To exit **AUX** mode and enjoy audio from other sources, press **AUX** repeatedly to select **[AUX OFF]**.



# 5 Listen to radio

## Tune to a radio station

### Tip

- Keep the unit away from other electronic devices to avoid radio interference.
- For better reception, fully extend and adjust the position of the antenna.

- 1 Slide **CROSS FADER** to the far left.
- 2 Press **TUNER** on the remote control, or **■** **A** on the main unit repeatedly to select FM or AM tuner.
- 3 Press and hold **◀◀** or **▶▶** for 2 seconds.
  - ↳ **[SEARCH]** (search) is displayed.
  - ↳ The radio tunes to a station with strong signal automatically.
- 4 Repeat step 3 to tune to more stations.
  - To tune to a station manually, press **◀◀** or **▶▶** repeatedly until you find optimal reception.

## Program radio stations automatically

### Note

- You can program a maximum of 30 FM and 10 AM radio stations.

- In tuner mode, press and hold **PROG** for 2 seconds to activate automatic program mode.
- ↳ **[AUTO]** (auto) is displayed.
  - ↳ The unit stores radio stations with sufficient signal strength automatically.
  - ↳ After all available radio stations are stored, the first stored radio station is broadcast automatically.

## Program radio stations manually

### Note

- You can program a maximum of 30 FM and 10 AM radio stations.

- 1 Tune to a radio station.
- 2 Press **PROG** to activate the program mode.
  - ↳ A position number is displayed.
- 3 Press **ALB/PRESET+/-** to allocate a number to this radio station, then press **PROG** to confirm.
- 4 Repeat steps 1-3 to program other stations.

### Tip

- To overwrite a programmed station, store another station in its place.

## Select a preset radio station

In tuner mode, press **ALB/PRESET+/-** to select a preset number:

## Change AM tuning grid

In some countries, the AM radio frequency step between adjacent channels is 10 kHz or 9 kHz.

- In AM tuner mode, press and hold **■** for more than five seconds.
  - ↳ All preset stations are erased and need to be re-programmed.

## 6 Adjust volume level and sound effect

### Adjust volume level

During play, press **VOL +/-** to increase or decrease volume.

### Mute sound

During play, press **MUTE** to mute or unmute sound.

### Apply AUTO DJ effect

The AUTO DJ function adds various sound and playback effects to your music automatically.

- To apply AUTO DJ effects, press **AUTO DJ** repeatedly to select between:
  - **[METAL]** (Metal), and
  - **[PARTY]** (party)
- To turn off the AUTO DJ effects, press **AUTO DJ** repeatedly to select **[OFF]** (Off).
- To adjust the occurrence frequency and sound level of the added effects, rotate the **DJ EFFECT** dial.

#### Note

- These effects are added by the application automatically and randomly.
- The function is only available in **USB A** mode.

### Apply DJ effects manually

You can also add the preset DJ effects by yourself.

- Press **DJ EFFECT** repeatedly to select an effect:
  - **[SCRATCH]** (scratch)
  - **[REVERB]** (reverb)
  - **[BEAT BOX]** (beat box)
  - **[YEAH]** (yeah)
- To turn off the DJ effects, press **DJ EFFECT** repeatedly to select **[OFF]** (off).
- To adjust the sound level of the added effects, rotate the **DJ EFFECT** dial.

#### Note

- The function is not available in **USB B** mode and **Audio in B** mode.

### Select a preset sound effect

The preset equalizer (EQ) feature enables you to enjoy special sound effects.

- During play, press **EQ** repeatedly to select:
  - **[FUNK]**
  - **[POP]**
  - **[FORRÓ]**
  - **[SERTANEJO]**
  - **[SAMBA]**

### Enhance bass

The best Dynamic Bass Enhancement (DBB) setting is generated automatically for each DSC selection. You can manually select the DBB setting that best suits your listening environment.

- During play, press **DBB** repeatedly to select:
  - **DBB 1**
  - **DBB 2**
  - **DBB 3**
  - **DBB OFF**

---

## Apply NX Bass effect

NX Bass effect adds clean and lively characteristics to your music with rather low background noise.

- During play, press **NX Bass**. Then the sound will change in 3 stages:
  - Stage 1: The sound volume increases to a higher level and stays at this level for 5 seconds.  
↳ **[FIRING]** (firing) is displayed.
  - Stage 2: The sound volume gradually decreases to its original level in 10 seconds.  
↳ **[DISCHARGE]** (discharge) is displayed.
  - Stage 3: The sound volume keeps at normal level for 40 seconds.
- If you press **NX Bass** again, **[RECHARGE]** (recharge) is displayed.

---

## Adjust equalizer settings

Custom Equalizer lets you increase or decrease the gain for specific frequency ranges, and adjust audio output to your own preferences.

- 1 Press **CUSTOM** on the main unit.
- 2 Switch the **Custom Equalizer** knobs to adjust the equalizer settings for each of the three frequency ranges.

# 7 Other features

---

## Mix sound

You can play from **Source A** (Disc/USB A/Bluetooth/Tuner/Audio in A mode) and from **Source B** (USB B/Audio in B mode) at the same time.

- 1 Play from **Source A**.
  - Disc: Select the CD source, and play a track in the loaded disc.
  - Tuner: Select the Tuner source, and tune to a radio station.
  - Audio in A: Select the Audio in A source, and play audio on the connected external device.
  - USB A: Select the USB A source, and play audio on the connected USB A device.
  - Bluetooth: Select the Bluetooth source, connect a Bluetooth device, and then play audio on the device.
- 2 Play from **Source B**.
  - Audio in B: Select the Audio in B source, and then play audio on the connected external device.
  - USB B: Select the USB B source, and then play audio on the connected USB B device.
- 3 Use the **CROSS FADER** control to adjust the output balance between the two tracks played from Source A and Source B.

---

## Speak or sing with a microphone

With this unit, you can speak or sing to a music source with a microphone.

- 1 Turn the **MIC** volume knob to the minimum level.

- 2 Connect a microphone (not supplied) to the **MIC** socket on the top panel.
- 3 Press **CD**, **TUNER**, **USB A**, **AUDIO A**, or **AUX** to select a source, and start play.
- 4 Sing or speak through the microphone.
  - To adjust the volume of the source, press **VOL +/-**.
  - To adjust the volume of the microphone, turn the **MIC** volume knob.

---

### Note

- The **MIC** input is designed for dynamic coil microphones with 750Ω +/- 30% impedance.

---

## Turn the decorative light on or off

- In power-on mode, press **LIGHT** repeatedly to adjust the decoration light around the loudspeakers, or turn the light off.

---

## Reverse the display

- During play, press **FLIP** to reverse the display.



---

## Listen through a headphone

---

### Note

- When you listen through a headphone, the loudspeaker cannot be muted.

- 1 Plug a headphone into the  socket on the top panel of the main unit.
- 2 Press  A/B to select an audio source to listen from: Source A or Source B.
- 3 Turn the  volume knob to adjust the headphone volume.

# 8 Product information

## Note

- Product information is subject to change without prior notice.

## Specifications

### Amplifier

Total Output Power	4 × 800 W, THD 10% *
Frequency Response	60 -16000 Hz, ±3 dB
Signal to Noise Ratio	>65 dBA
Audio Input	2V RMS Rin≥22 kohm

### Disc

Laser type	Semiconductor
Disc diameter	12cm/8cm
Support disc	CD-DA, CD-R, CD- RW, MP3-CD
Audio DAC	24Bits / 44.1kHz
Total Harmonic Distortion	<0.8% (1 kHz)
Frequency Response	4Hz - 20kHz (44.1kHz)
S/N Ratio	>65 dBA

### Speakers

Speaker Impedance	4 ohm
Speaker Driver	Woofer: 2 × 8"; Midrange: 2 × 4"; Tweeter: 2 × 0.5" dome
Sensitivity	90±3dB/m/W

### Tuner

Tuning Range	FM: 87.5 - 108 MHz; AM: 531 - 1602 kHz (9 KHz); 530 - 1700 KHz (10 KHz)
Tuning Grid	100 KHz (FM); 9 KHz/10 KHz (AM)
Number of Presets	30 FM, 10 AM
- Mono, 26dB S/N Ratio	<22 dBf
Search Selectivity	<35 dBf
Total Harmonic Distortion	<2 %
Signal to Noise Ratio	>45 dB

### Bluetooth

Bluetooth Version	V2.1+EDR
Bluetooth Frequency Band	2.4GHz ~ 2.48GHz ISM Band
Bluetooth Profile	A2DP, AVRCP 1.0
Range	10 m (Free space)

### General information

AC Power	110 -127V/220 - 240V~, 50/60Hz
Operation power consumption	160 W
Standby power consumption	40 W
USB Direct	Version 2.0 HS, 5V, 500mA
Headphone Output	5.0 mW 2 × 16 Ω
Dimensions	
- Main Unit (W × H × D)	358 × 1091 × 471 mm
- Speaker box (W × H × D)	360 × 1065 × 471 mm
Weight	
- Main Unit	26.3 kg
- Speaker box	22.2 kg

- \* Low Channel: 1KHz; Audio In B: 2,3V; Tolerance: -0,5dB  
High Channel: 6,3KHz; Audio In B: 2,3V; Tolerance: -0,5dB

---

## USB playability information

### Compatible USB devices:

- USB flash memory (USB 2.0)
- USB flash players (USB 2.0)
- memory cards (requires an additional card reader to work with this unit)

### Supported formats:

- USB or memory file format FAT12, FAT16, FAT32 (sector size: 512 bytes)
- MP3 bit rate (data rate): 32-320 Kbps and variable bit rate
- Directory nesting up to a maximum of 8 levels
- Number of albums/ folders: maximum 99
- Number of tracks/titles: maximum 999
- ID3 tag v1.2 or later
- File name in Unicode UTF8 (maximum length: 128 bytes)

### Unsupported formats:

- Empty albums: an empty album is an album that does not contain MP3 files, and is not be shown in the display.
- Unsupported file formats are skipped. For example, Word documents (.doc) or MP3 files with extension .dlf are ignored and not played.
- AAC, WAV, PCM audio files
- WMA files

---

## Supported MP3 disc formats

- ISO9660, Joliet
- Maximum title number: 999 (depending on file name length)
- Maximum album number: 99
- Supported sampling frequencies: 32 kHz, 44.1kHz, 48 kHz
- Supported Bit-rates: 32-320 (kbps), variable bit rates
- ID3 tag v1.2 or later
- Directory nesting up to a maximum of 8 levels

---

## Maintenance

### Clean the cabinet

- Use a soft cloth slightly moistened with a mild detergent solution. Do not use a solution containing alcohol, spirits, ammonia or abrasives.

### Clean discs

- When a disc becomes dirty, clean it with a cleaning cloth. Wipe the disc from the centre out.

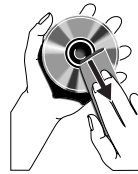

- Do not use solvents such as benzene, thinner, commercially available cleaners, or antistatic spray intended for analogue records.

### Clean the disc lens

- After prolonged use, dirt or dust may accumulate at the disc lens. To ensure good play quality, clean the disc lens with Philips CD lens cleaner or any commercially available cleaner. Follow the instructions supplied with cleaner.

# 9 Troubleshooting



## Caution

- Never remove the casing of this unit.

To keep the warranty valid, never try to repair the system yourself.

If you encounter problems when using this unit, check the following points before requesting service. If the problem remains unsolved, go to the Philips web site ([www.philips.com/support](http://www.philips.com/support)). When you contact Philips, ensure that your unit is nearby and the model number and serial number are available.

---

## General

### No power

- Make sure that the AC power plug of the unit is connected properly.
- Make sure that there is power at the AC outlet.

### No sound or poor sound

- Adjust the volume.
- Check that the speakers are connected correctly.
- Check if speakers are muted. Press **MUTE** to restore sound.

### No response after pressing some source keys

- Make sure that the product is not in standby mode.
- Check if the product is in **AUX** mode. If yes, press **AUX** repeatedly to exit the **AUX** mode first, then try again.

### No response from the unit

- Disconnect and reconnect the AC power plug, then turn on the unit again.

### Remote control does not work

- Before you press any function button, first select the correct source with the remote control instead of the main unit.
- Reduce the distance between the remote control and the unit.
- Insert the batteries with their polarities (+/- signs) aligned as indicated.
- Replace the batteries.
- Aim the remote control directly at the sensor on the front of the main unit.

### No disc detected

- Insert a disc.
- Check if the disc is inserted upside down.
- Wait until the moisture condensation at the lens has cleared.
- Replace or clean the disc.
- Use a finalized CD or correct format disc.

### Cannot display some files in USB device

- The number of folders or files in the USB device has exceeded a certain limit. This phenomenon is not a malfunction.
- The formats of these files are not supported.

### USB device not supported

- The USB device is incompatible with the unit. Try another one.

### Cannot apply sound effects when playing from a USB B device.

- USB B mode does not support **DBB**, **DSC**, **DJ EFFECT** or **AUTO DJ** effects.

### Cannot delete files from a USB B device.

- USB B mode does not support USB Delete function.

### Poor radio reception

- Increase the distance between the unit and other electrical appliances.
- Adjust the position of the antenna for better reception.

---

## About Bluetooth device

**The audio quality is poor after connection with a Bluetooth-enabled device.**

- The Bluetooth reception is poor. Move the device closer to this product or remove any obstacle between them.

**Cannot connect with the device.**

- The Bluetooth function of the device is not enabled. Refer to the user manual of the device for how to enable the function.
- This product is already connected with another Bluetooth-enabled device. Disconnect that device and then try again.

**The paired device connects and disconnects constantly.**

- The Bluetooth reception is poor. Move the device closer to this product or remove any obstacle between them.
- For some devices, Bluetooth connection may be deactivated automatically as a power-saving feature. This does not indicate any malfunction of this product.



# 10 Notice

Any changes or modifications made to this device that are not expressly approved by Gibson Innovations may void the user's authority to operate the equipment.

---

## Care of the environment

### Disposal of your old product



**WARNING:** Care with the use and disposal of batteries.

- Do not dispose of batteries along with normal household waste.
- The improper disposal of batteries may present risks to the environment and human health.
- In order to contribute to environmental quality and your health, Philips will accept batteries sold or supplied with its products that have reached the end of their life; these will be forwarded for environmentally correct disposal. Philips provides collection points at Technical Assistance.

### Environmental information

All unnecessary packaging has been omitted. We have tried to make the packaging easy to separate into three materials: cardboard (box), polystyrene foam (buffer) and polyethylene (bags, protective foam sheet.)

Your system consists of materials which can be recycled and reused if disassembled by a specialized company. Please observe the local regulations regarding the disposal of packaging materials, exhausted batteries and old equipment.

---

## Trademark notice



The Bluetooth® word mark and logos are registered trademarks owned by Bluetooth SIG, Inc. and any use of such marks by Gibson Innovations Limited is under license. Other trademarks and trade names are those of their respective owners.



The 'N' Mark is a trademark or registered trademark of NFC Forum, Inc. in the United States and in other countries.



This is CLASS II apparatus with double insulation, and no protective earth provided.



The making of unauthorized copies of copy-protected material, including computer programs, files, broadcasts and sound recordings, may be an infringement of copyrights and constitute a criminal offence. This equipment should not be used for such purposes.



Specifications are subject to change without notice.

2015 © Gibson Innovations Limited. All rights reserved.

This product has been manufactured by, and is sold under the responsibility of Gibson Innovations Ltd., and Gibson Innovations Ltd. is the warrantor in relation to this product.

Philips and the Philips Shield Emblem are registered trademarks of Koninklijke Philips N.V. and are used under license from Koninklijke Philips N.V.

NTX800X\_78\_UM\_V2.0

