

Register your product and get support at
www.philips.com/welcome

MCM169



EN	User manual	3
KO	사용 설명서	21

PHILIPS

Contents

1 Important	4	8 USB record	15
Safety	4	Auto record from CD to USB	15
Notice	5		
2 Your Micro Hi-Fi System	5	9 Other features	15
Introduction	5	Set the alarm timer	15
What's in the box	5	Set the sleep timer	16
Overview of the main unit	6	Listen to an external device	16
Overview of the remote control	7	Delete files in the USB device	16
3 Get started	9	10 Product information	16
Connect speakers	9	Specifications	16
Connect power	9	USB playability information	17
Prepare the remote control	10	Maintenance	17
Auto install radio stations	10	11 Troubleshooting	18
Set clock	10		
Turn on	11		
4 Play	11		
Play disc	11		
Play from USB	11		
5 Play options	12		
Repeat and random play	12		
Program tracks	12		
Display play information	13		
6 Adjust sound	13		
Adjust volume level	13		
Select a preset sound effect	13		
Enhance bass	13		
Mute sound	13		
7 Listen to radio	14		
Tune to a radio station	14		
Program radio stations automatically	14		
Program radio stations manually	14		
Select a preset radio station	14		
Change MW tuning grid	14		

1 Important

Safety

Important Safety Instructions

- ① Read these instructions.
- ② Keep these instructions.
- ③ Heed all warnings.
- ④ Follow all instructions.
- ⑤ Do not use this apparatus near water.
- ⑥ Clean only with dry cloth.
- ⑦ Do not block any ventilation openings. Install in accordance with the manufacturer's instructions.
- ⑧ Do not install near any heat sources such as radiators, heat registers, stoves, or other apparatus (including amplifiers) that produce heat.
- ⑨ Protect the power cord from being walked on or pinched, particularly at plugs, convenience receptacles, and the point where they exit from the apparatus.
- ⑩ Only use attachments/accessories specified by the manufacturer.
- ⑪ Use only with the cart, stand, tripod, bracket, or table specified by the manufacturer or sold with the apparatus. When a cart is used, use caution when moving the cart/apparatus combination to avoid injury from tip-over.
- ⑫ Unplug this apparatus during lightning storms or when unused for long periods of time.
- ⑬ Refer all servicing to qualified service personnel. Servicing is required when the apparatus has been damaged in any



way, such as power-supply cord or plug is damaged, liquid has been spilled or objects have fallen into the apparatus, the apparatus has been exposed to rain or moisture, does not operate normally, or has been dropped.

- ⑭ **Battery usage CAUTION** – To prevent battery leakage which may result in bodily injury, property damage, or damage to the unit:
 - Install all batteries correctly, + and - as marked on the unit.
 - Do not mix batteries (old and new or carbon and alkaline, etc.).
 - Remove batteries when the unit is not used for a long time.
 - The batteries shall not be exposed to excessive heat such as sunshine, fire or the like.
- ⑮ Apparatus shall not be exposed to dripping or splashing.
- ⑯ Do not place any sources of danger on the apparatus (e.g. liquid filled objects, lighted candles).
- ⑰ This product may contain lead and mercury. Disposal of these materials may be regulated due to environmental considerations. For disposal or recycling information, please contact your local authorities or the Electronic Industries Alliance: www.eiae.org.
- ⑱ Where the MAINS plug or an appliance coupler is used as the disconnect device, the disconnect device shall remain readily operable.



Warning

- Never remove the casing of this apparatus.
- Never lubricate any part of this apparatus.
- Never place this apparatus on other electrical equipment.
- Keep this apparatus away from direct sunlight, naked flames or heat.
- Never look into the laser beam inside this apparatus.
- Ensure that you always have easy access to the power cord, plug or adaptor to disconnect this apparatus from the power.

Notice

Any changes or modifications made to this device that are not expressly approved by Philips Consumer Lifestyle may void the user's authority to operate the equipment.



**Be responsible
Respect copyrights**

The making of unauthorized copies of copy-protected material, including computer programs, files, broadcasts and sound recordings, may be an infringement of copyrights and constitute a criminal offence. This equipment should not be used for such purposes.

Environmental information

All unnecessary packaging has been omitted. We have tried to make the packaging easy to separate into three materials: cardboard (box), polystyrene foam (buffer) and polyethylene (bags, protective foam sheet.)

Your system consists of materials which can be recycled and reused if disassembled by a specialized company. Please observe the local regulations regarding the disposal of packaging materials, exhausted batteries and old equipment.



Windows Media and the Windows logo are trademarks, or registered trademarks of Microsoft Corporation in the United States and/or other countries.

This apparatus includes this label:



2 Your Micro Hi-Fi System

Congratulations on your purchase, and welcome to Philips! To fully benefit from the support that Philips offers, register your product at www.Philips.com/welcome.

Introduction

With this unit, you can enjoy audio discs, USB devices, external devices, or radio stations. The unit offers you multiple sound effect settings that enrich sound with Digital Sound Control (DSC) and Dynamic Bass Boost (DBB). The unit supports the following media formats:



What's in the box

Check and identify the contents of your package:

- Main unit
- Loudspeaker boxes x 2
- Remote control
- MP3 link cable
- Quick start guide
- User manual

Overview of the main unit

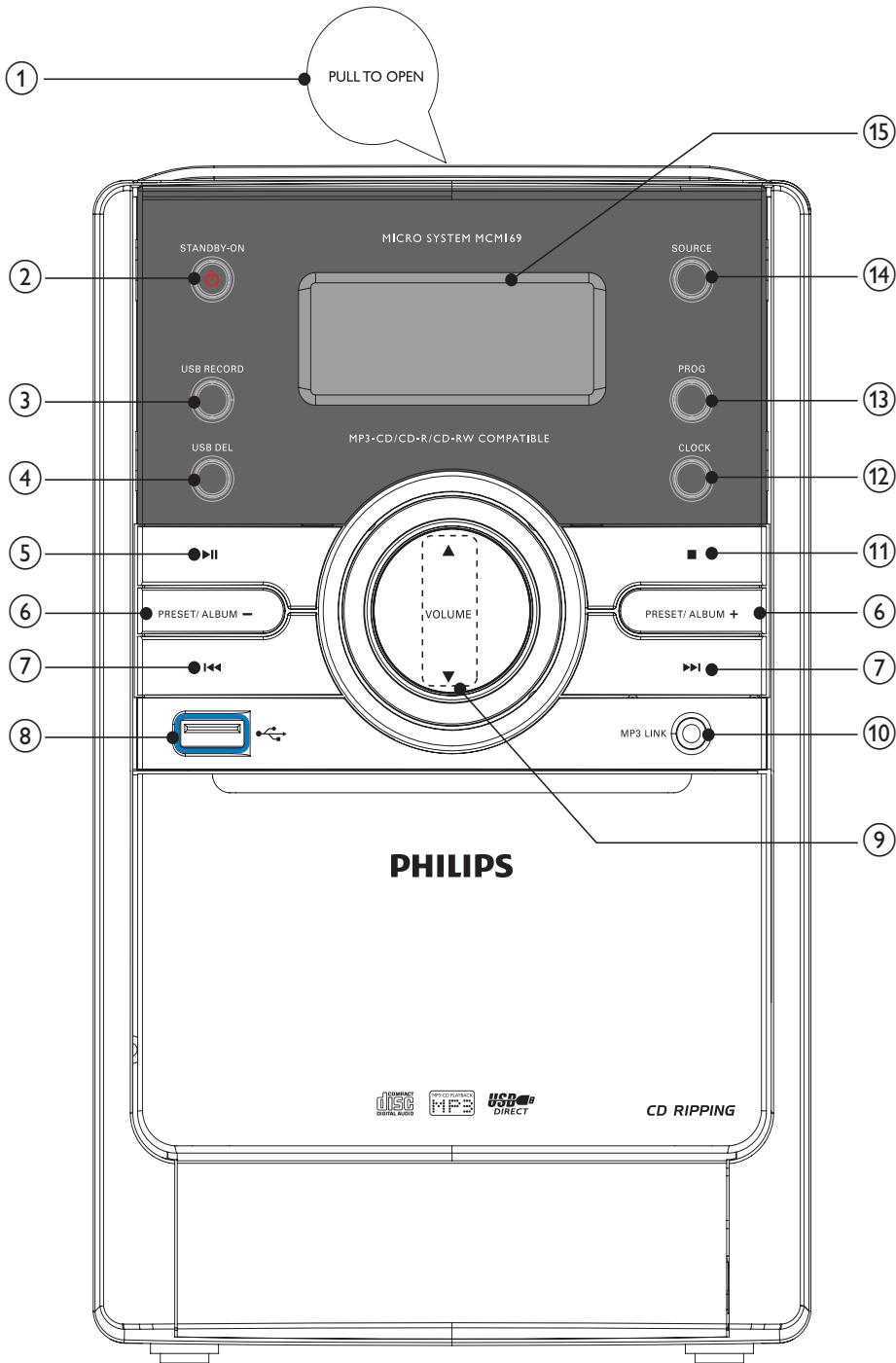

- ① **PULL TO OPEN**
 - Open or close the disc compartment.
- ② **STANDBY-ON**
 - Turn on the unit, or switch to standby mode, or switch to Eco Power Standby.
- ③ **USB RECORD**
 - Record from a disc to a USB device.
- ④ **USB DEL**
 - Delete audio files stored on a USB device.
- ⑤ **▶||**
 - Start or pause play.
- ⑥ **PRESET/ALBUM+/-**
 - Select a preset radio station.
 - Skip to the previous/next album.
- ⑦ **◀◀▶▶**
 - Skip to the previous/next track.
 - Search within a track/ disc/USB.
 - Tune to a radio station.
 - Adjust time.
- ⑧ **🔌**
 - Jack for a USB device.
- ⑨ **VOLUME▲▼**
 - Adjust volume.
- ⑩ **MP3 LINK**
 - Audio input jack (3.5mm) for an external audio device.
- ⑪ **■**
 - Stop play or erase a program.
- ⑫ **CLOCK**
 - Set the clock.
 - View the clock.
 - During play, select display information.
- ⑬ **PROG**
 - Program tracks.
 - Program radio stations.
 - Select 12 hour or 24 hour format.

- ⑭ **SOURCE**
 - Select a source.
- ⑮ **Display panel**
 - Show current status.

Overview of the remote control

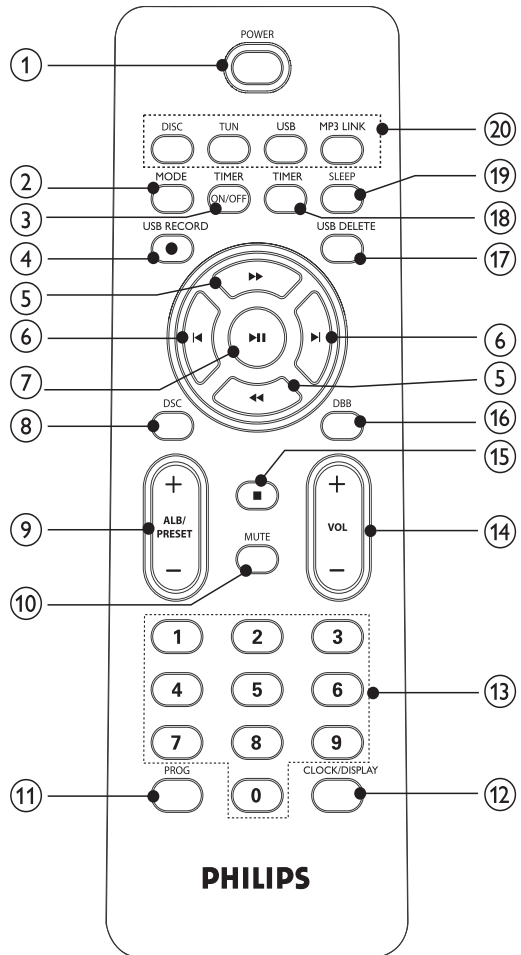

- ① **POWER**
 - Turn on the unit, switch to standby mode, or switch to Eco Power standby.

- ② **MODE**
 - Select repeat play or random play.
- ③ **TIMER ON/OFF**
 - Turn on or off alarm timer.
- ④ **USB RECORD**
 - Record from a disc to a USB device.
- ⑤ **◀◀▶▶**
 - Search within a track/ disc/USB.
 - Tune to a radio station.
 - Adjust time.
- ⑥ **◀▶**
 - Skip to the previous/next track.
- ⑦ **▶||**
 - Start or pause play.
- ⑧ **DSC**
 - Select a preset sound setting.
- ⑨ **ALB/PRESET+/-**
 - Skip to the previous/next album.
 - Select a preset radio station.
- ⑩ **MUTE**
 - Mute volume.
- ⑪ **PROG**
 - Program tracks.
 - Program radio stations.
 - Select 12 hour or 24 hour format.
- ⑫ **CLOCK/DISPLAY**
 - Set the clock.
 - View the clock.
 - During play, select display information.
- ⑬ **Numeric keypad**
 - Select a track from a disc directly.
- ⑭ **VOL +/-**
 - Adjust volume.
- ⑮ **■**
 - Stop play or erase a program.
- ⑯ **DBB**
 - Turn on or off dynamic bass enhancement.
- ⑰ **USB DELETE**
 - Delete audio files stored on a USB device.
- ⑱ **TIMER**
 - Set an alarm timer.
- ⑲ **SLEEP**
 - Set the sleep timer.
- ⑳ **Source selection keys**
 - Select a source.

3 Get started



Caution

- Use of controls or adjustments or performance of procedures other than herein may result in hazardous radiation exposure or other unsafe operation.

Always follow the instructions in this chapter in sequence.

If you contact Philips, you will be asked for the model and serial number of this apparatus. The model number and serial number are on the back of the apparatus. Write the numbers here:
Model No. _____
Serial No. _____

Connect speakers



Note

- For optimal sound, use the supplied speakers only.
- Connect only speakers with impedance that is the same or higher than the supplied speakers. Refer to the Specifications section of this manual.

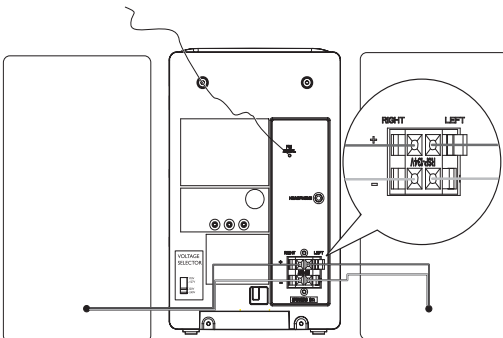

Note

- Ensure that the colors of the speaker wires and terminals are matched.

- 1 Hold down the socket flap.
- 2 Insert the stripped part of the wire completely.
 - Insert the right speaker wires to "RIGHT", left speaker wires to "LEFT".
 - Insert the red wires to "+", black wires to "-".
- Release the socket flap.

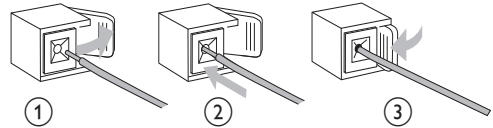

Connect power

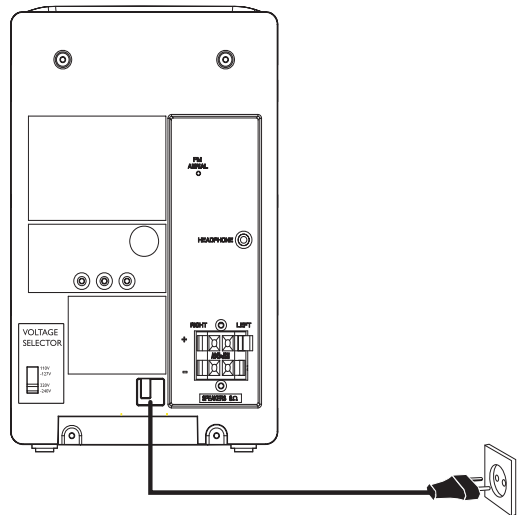

Caution

- Risk of product damage! Ensure that the power supply voltage corresponds to the voltage set on the voltage selector on the back of the unit.
- Before connecting the AC power cord, ensure you have completed all other connections.

Note

- The type plate is located on the back of the main unit.

- 1 Connect the AC power cable to:
 - the main unit.
 - the wall socket.

Prepare the remote control

Caution

- Risk of explosion! Keep batteries away from heat, sunshine or fire. Never discard batteries in fire.

To replace the remote control battery:

- 1 Open the battery compartment.
- 2 Insert 2 AAA batteries with correct polarity (+/-) as indicated.
- 3 Close the battery compartment.

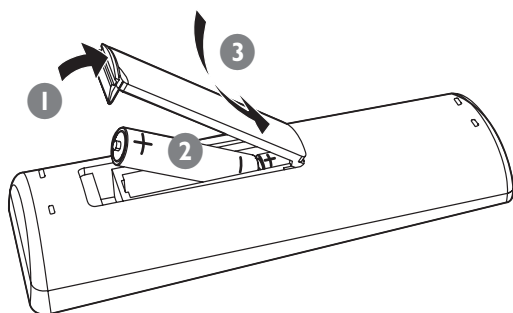

Note

- If you are not going to use the remote control for a long time, remove the batteries.
- Do not use old and new or different types of batteries in combination.
- Batteries contain chemical substances, so they should be disposed of properly.

Auto install radio stations

When you connect power and no radio stations are stored, the unit automatically begins to store radio stations.

- 1 Connect the unit to the power supply.
 - ↳ [AUTO INSTALL - PRESS PLAY] (auto install - press the PLAY button) is displayed.
- 2 Press **▶||** on the main unit to start installation.
 - ↳ [AUTO] (auto) is displayed.
 - ↳ The unit automatically stores radio stations with sufficient signal strength.
 - ↳ When all the available radio stations are stored, the first preset radio station is broadcast automatically.

Set clock

- 1 Press and hold **CLOCK/DISPLAY** to activate the clock setting mode.
 - ↳ The 12 hour or 24 hour format is displayed.
- 2 Press **PROG** repeatedly to select 12 hour or 24 hour format.
- 3 Press **CLOCK/DISPLAY** to confirm.
 - ↳ The hour digits are displayed and begin to blink.
- 4 Press **◀▶** to set the hour.
- 5 Press **CLOCK/DISPLAY** to confirm.
 - ↳ The minute digits are displayed and begin to blink.
- 6 Press **◀▶** to set the minute.
- 7 Press **CLOCK/DISPLAY** to confirm.

Tip

- To view the clock during play, press **CLOCK/DISPLAY** repeatedly until the clock is displayed.

Turn on

- 1 Press **POWER**.
↳ The unit switches to the last selected source.

Switch to standby

- 1 Press **POWER** to switch the unit to standby mode.
↳ The clock (if set) appears on the display panel.

4 Play

Play disc

- 1 Press **DISC** to select the disc source.
- 2 Lift the disc compartment door on the top panel to open the disc compartment.
- 3 Insert a disc with the printed side facing up, then close the disc compartment.
- 4 If the disc doesn't play, press **▶||**.
 - To pause/resume play, press **▶||**.
 - To stop play, press **■**.
 - To select another track, press **◀|▶**, or press a numeric button.
 - To select an album, press **ALB/PRESET+/-**.
 - To search within a track, press and hold **◀◀▶▶**, then release to resume normal play.

Play from USB

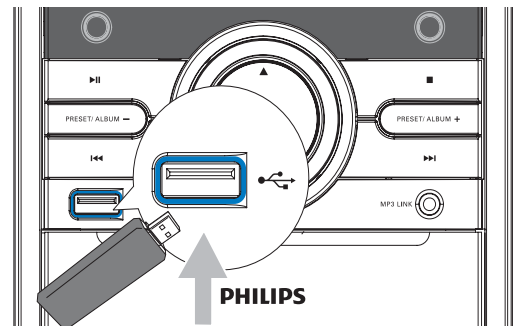

Note

- Ensure that the USB device contains playable audio contents for supported formats.

- 1 Plug the USB device into the socket  of this unit.
- 2 Press **USB** to select the USB source.

- 3 Press **ALB/PRESET+/-** to select a folder.
- 4 Press **◀/▶** to select an audio file.
- 5 If the USB device doesn't play, press **▶||**.
 - To pause/resume play, press **▶||**.
 - To stop play, press **■**.
 - To search within an audio file, press and hold **◀◀▶▶**, then release to resume normal play.

5 Play options

Repeat and random play

- 1 Press **MODE** repeatedly to select:
 - **[REP]** (repeat): the current track is played repeatedly.
 - **[REP ALL]** (repeat all): all tracks are played repeatedly.
 - **[SHUF]** (shuffle): all tracks are played randomly.
- 2 To return to normal play, press **MODE** repeatedly until play mode is no longer displayed.



Tip

- Shuffle play cannot be selected when you play programmed tracks.

Program tracks

You can program a maximum of 40 tracks.

- 1 At CD/USB mode, in the stop position, press **PROG** to activate the program mode.
 - ↳ **[PROG]** (program) blinks on the display.
- 2 For MP3/WMA tracks, press **ALB/PRESET+/-** to select an album.
- 3 Press **◀/▶** to select a track number, then press **PROG** to confirm.
- 4 Repeat steps 2 to 3 to select and store all tracks to program.
- 5 Press **▶||** to play the programmed tracks.
 - ↳ During play, **[PROG]** (program) is displayed.
 - To erase the program, in the stop position, press **■**.

Display play information

- 1 During play, press **CLOCK/DISPLAY** repeatedly to select different play information.

6 Adjust sound

Adjust volume level

- 1 During play, press **VOL +/-** to increase/decrease the volume level.

Select a preset sound effect

- 1 During play, press **DSC** repeatedly to select:
 - [POP] (pop)
 - [JAZZ] (jazz)
 - [CLASSIC] (classic)
 - [ROCK] (rock)

Enhance bass

- 1 During play, press **DBB** to turn on or off dynamic bass enhancement.
 - ↳ If DBB is activated, DBB is displayed.

Mute sound

- 1 During play, press **MUTE** to mute/unmute sound.

7 Listen to radio

Tune to a radio station

- 1 Press **TUN** repeatedly to select FM or MW.
- 2 Press and hold **◀▶** for more than 2 seconds.
 - ↳ [SEARCH] (search) is displayed.
 - ↳ The radio tunes to a station with strong reception automatically.
- 3 Repeat step 2 to tune to more stations.
 - To tune to a weak station, press **◀▶** repeatedly until you find optimal reception.

Program radio stations automatically

You can program a maximum of 40 (FM + MW) preset radio stations.

- 1 In the tuner mode, press and hold **PROG** for 2 seconds to activate automatic program mode.
 - ↳ [AUTO] (auto) is displayed.
 - ↳ All available stations are programmed in the order of waveband reception strength.
 - ↳ The first programmed radio station is broadcast automatically.

Program radio stations manually

You can program a maximum of 40 (FM + MW) preset radio stations.

- 1 Tune to a radio station.

- 2 Press **PROG** to activate program mode.
 - ↳ [PROG] (program) blinks on the display.
- 3 Press **ALB/PRESET+/-** to allocate a number to this radio station, then press **PROG** to confirm.
- 4 Repeat the above steps to program other stations.

Tip

- To overwrite a programmed station, store another station in its place.

Select a preset radio station

- 1 In tuner mode, press **ALB/PRESET+/-** to select a preset number.

Tip

- Position the antenna as far as possible from TV, VCR or other radiation source.
- For optimal reception, fully extend and adjust the position of the antenna.

Change MW tuning grid

In some countries, the MW radio frequency step between adjacent channels is 9 kHz.

- 1 Select the MW radio source.
- 2 Press and hold **■** on the main unit for more than 5 seconds.
 - ↳ The frequency step is changed to 9 kHz.
 - ↳ All preset stations are erased and need to be re-programmed.

8 USB record

Note

- This product supports recording to MSC devices (MTP devices are excluded).

You can record the audio files on a disc into a USB device. Audio CD tracks and MP3 files are recorded in .mp3 format, and WMA files are recorded in .wma format.

The first time you record to USB, a folder called 'PHILIPS' is automatically created in the USB device. Each time you record to USB, the recorded files are stored in a sub-folder in the 'PHILIPS' folder. Files and sub-folders are named numerically in the order in which they are created.

Auto record from CD to USB

- 1 Press **DISC** to select the disc source.
- 2 Load a disc.
 - To select a track from which a recording starts, press the numeric buttons.
- 3 Plug the USB device into the socket  of this unit.
- 4 Press **USB RECORD** repeatedly to select:
 - [RECORD ONE] (record one): the first/current track is recorded.
 - [RECORD ALL] (record all): all tracks/ the remaining tracks are recorded.
 ↳ Disc play starts automatically from the beginning of the disc/the selected track, and the recording starts.
 - To stop recording, press **■**.

Note

- If the USB device does not have enough memory to store the CD track, a message about full memory is displayed.



9 Other features

Set the alarm timer

This unit can be used as an alarm clock. The DISC, TUNER or USB is activated to play at a preset time.

- 1 Ensure that you have set the clock correctly.
- 2 Press and hold **TIMER**.
- 3 Press **DISC**, **TUN** or **USB** to select a source.
- 4 Press **TIMER** to confirm.
 - ↳ The hour digits are displayed and begin to blink.
- 5 Press **◀▶** to set the hour.
- 6 Press **TIMER** to confirm.
 - ↳ The minute digits are displayed and begin to blink.
- 7 Press **◀▶** to set the minute.
- 8 Press **TIMER** to confirm.
 - ↳ The timer is set and activated.

Activate and deactivate the alarm timer

- 1 Press **TIMER ON/OFF** repeatedly to activate or deactivate the timer.
 - ↳ If the timer is activated, the display shows .
 - ↳ If the timer is deactivated,  disappears on the display.

Note

- In MP3 link mode, the alarm timer cannot be set.
- If disc source is selected and the track cannot be played, tuner is activated automatically.

Set the sleep timer

This unit can switch to standby automatically after a set period of time.

- 1 When the unit is turned on, press **SLEEP** repeatedly to select a set period of time (in minutes).
 - ↳ When sleep timer is activated, the display shows **zz**.
- 2 Press **SLEEP** repeatedly until "0" is displayed.
 - ↳ When sleep timer is deactivated, **zz** disappears on the display.

Listen to an external device

You can also listen to an external audio device through this unit.

- 1 Press **MP3 LINK** to select the MP3 link source.
- 2 Connect the supplied MP3 link cable to:
 - the **MP3 LINK** jack (3.5mm) on the unit.
 - the headphone jack on an external device.
- 3 Start to play the device (refer to the device's user manual).

Delete files in the USB device

- 1 During USB play, press **◀▶** to select a track.
- 2 Press **USB DELETE**.
 - ↳ A confirmation message is displayed.
- 3 When the above confirmation message is displayed, press **USB DELETE** again to confirm.
 - To cancel, press **■**.
 - ↳ After you delete the file, the USB play stops.

10 Product information

Note

- Product information is subject to change without prior notice.

Specifications

Amplifier

Rated Output Power	2X5W RMS
Frequency Response	60 - 16kHz, ±3dB
Signal to Noise Ratio	>65dB
Aux Input	0.5 V RMS 20kohm

Disc

Laser Type	Semiconductor
Disc Diameter	12cm/8cm
Support Disc	CD-DA, CD-R, CD-RW, MP3-CD, WMA-CD
Audio DAC	24Bits / 44.1kHz
Total Harmonic Distortion	<1%
Frequency Response	60Hz -16kHz (44.1kHz)
S/N Ratio	>65dBA

Tuner

Tuning range	FM: 87.5 - 108MHz; MW: 531 - 1602kHz (9KHz)
Tuning grid	50KHz (FM); 9KHz (MW)
Number of presets	40 (FM + MW)
MW	loop antenna

Speakers

Speaker Impedance	4ohm
Speaker Driver	3.5"woofer+0.8" tweeter
Sensitivity	>82dB/m/W

General information

AC power	220V, 60Hz
Operation Power Consumption	20W
Standby Power Consumption	<2W
USB Direct	Version 2.0/1.1
Dimensions	
- Main Unit (W x H x D)	147 x 231 x 209mm
- Speaker Box (W x H x D)	134 x 233 x 153mm
Weight	
- With Packing	4.75 kg
- Main Unit	1.95 kg
- Speaker Box	2 x 1.2 kg

USB playability information

Compatible USB devices:

- USB flash memory (USB 2.0 or USB 1.1)
- USB flash players (USB 2.0 or USB 1.1)
- memory cards (requires an additional card reader to work with this unit)

Supported formats:

- USB or memory file format FAT12, FAT16, FAT32 (sector size: 512 bytes)
- MP3 bit rate (data rate): 32-320 Kbps and variable bit rate
- WMA v9 or earlier
- Directory nesting up to a maximum of 8 levels
- Number of albums/ folders: maximum 99
- Number of tracks/titles: maximum 999
- ID3 tag v2.0 or later
- File name in Unicode UTF8 (maximum length: 128 bytes)

Unsupported formats:

- Empty albums: an empty album is an album that does not contain MP3/WMA files, and is not be shown in the display.
- Unsupported file formats are skipped. For example, Word documents (.doc) or MP3 files with extension .dlf are ignored and not played.
- AAC, WAV, PCM audio files
- DRM protected WMA files (.wav, .m4a, .m4p, .mp4, .aac)
- WMA files in Lossless format

Maintenance

Clean the cabinet

- Use a soft cloth slightly moistened with a mild detergent solution. Do not use a solution containing alcohol, spirits, ammonia or abrasives.

Clean discs

- When a disc becomes dirty, clean it with a cleaning cloth. Wipe the disc from the centre out.



- Do not use solvents such as benzene, thinner, commercially available cleaners, or antistatic spray intended for analogue records.

Clean the disc lens

- After prolonged use, dirt or dust may accumulate at the disc lens. To ensure good play quality, clean the disc lens with Philips CD lens cleaner or any commercially available cleaner. Follow the instructions supplied with cleaner.

11 Troubleshooting



Warning

- Never remove the casing of this apparatus.

To keep the warranty valid, never try to repair the system yourself.

If you encounter problems when using this apparatus, check the following points before requesting service. If the problem remains unsolved, go to the Philips web site (www.philips.com/welcome). When you contact Philips, ensure that the apparatus is nearby and the model number and serial number are available.

No power

- Ensure that the AC power plug of the unit is connected properly.
- Ensure that there is power at the AC outlet.
- To save power, the unit switches to standby automatically 15 minutes after a play reaches the end and no control is operated.

No sound or poor sound

- Adjust the volume.
- Disconnect the headphones.
- Check that the speakers are connected correctly.
- Check if the stripped speaker wires are clamped.

Left and right sound outputs reversed

- Check the speaker connections and location.

No response from the unit

- Disconnect and reconnect the AC power plug, then turn on the unit again.

Remote control does not work

- Before you press any function button, first select the correct source with the remote control instead of the main unit.

- Reduce the distance between the remote control and the unit.
- Insert the batteries with their polarities (+/- signs) aligned as indicated.
- Replace the batteries.
- Aim the remote control directly at the sensor on the front of the main unit.

No disc detected

- Insert a disc.
- Check if the disc is inserted upside down.
- Wait until the moisture condensation at the lens has cleared.
- Replace or clean the disc.
- Use a finalized CD or correct format disc.

Cannot display some files in USB device

- The number of folders or files in the USB device has exceeded a certain limit. This phenomenon is not a malfunction.
- The formats of these files are not supported.

USB device not supported

- The USB device is incompatible with the unit. Try another one.

Poor radio reception

- Increase the distance between the unit and your TV or VCR.
- Fully extend and adjust the FM antenna.

Timer does not work

- Set the clock correctly.
- Switch on the timer.

Clock/timer setting erased

- Power has been interrupted or the power cord has been disconnected.
- Reset the clock/timer.

