

Register your product and get support at
www.philips.com/welcome

DCM292



EN	User manual	3
KO	사용 설명서	21
ZH-TW	使用手冊	39

PHILIPS

Contents

1 Important	4
Safety	4
Notice	5

2 Your Micro Hi-Fi System	6
Introduction	6
What's in the box	6
Overview of the main unit	7
Overview of the remote control	8

3 Get started	10
Placement	10
Prepare the remote control	10
Connect power	10
Auto install radio stations	11
Set clock	11
Turn on	11

4 Play	12
Play a disc	12
Play from USB	12
Play iPod/iPhone	12

5 Listen to radio	13
Tune to a radio station	13
Program radio stations automatically	13
Program radio stations manually	13
Select a preset radio station	14

6 Play options	14
Pause/resume play	14
Skip to a track	14
Search within a track	14
Select repeat/shuffle play options	14
Program tracks	15
Display time	15
Adjust volume level	15
Mute sound	15
Select a preset sound effect	15
Enhance bass	15

7 Other features	16
Set the alarm timer	16
Set the sleep timer	16
Play from an external device	16

8 Product information	17
Specifications	17
USB playability information	17
Supported MP3 disc formats	18
Maintenance	18

9 Troubleshooting	18
--------------------------	-----------

1 Important

Safety

- ① Read these instructions.
- ② Keep these instructions.
- ③ Heed all warnings.
- ④ Follow all instructions.
- ⑤ Do not use this apparatus near water.
- ⑥ Clean only with dry cloth.
- ⑦ Do not block any ventilation openings. Install in accordance with the manufacturer's instructions.
- ⑧ Do not install near any heat sources such as radiators, heat registers, stoves, or other apparatus (including amplifiers) that produce heat.
- ⑨ Protect the power cord from being walked on or pinched, particularly at plugs, convenience receptacles, and the point where they exit from the apparatus.
- ⑩ Only use attachments/accessories specified by the manufacturer.
- ⑪ Use only with the cart, stand, tripod, bracket, or table specified by the manufacturer or sold with the apparatus. When a cart is used, use caution when moving the cart/apparatus combination to avoid injury from tip-over. 
- ⑫ Unplug this apparatus during lightning storms or when unused for long periods of time.
- ⑬ Refer all servicing to qualified service personnel. Servicing is required when the apparatus has been damaged in any way, such as power-supply cord or plug is damaged, liquid has been spilled or objects have fallen into the apparatus, the apparatus has been exposed to rain or moisture, does not operate normally, or has been dropped.
- ⑭ Battery usage CAUTION – To prevent battery leakage which may result in bodily injury, property damage, or damage to the unit:
 - Install all batteries correctly, + and - as marked on the unit.
 - Do not mix batteries (old and new or carbon and alkaline, etc.).
 - Remove batteries when the unit is not used for a long time.
- ⑮ Apparatus shall not be exposed to dripping or splashing.
- ⑯ Do not place any sources of danger on the apparatus (e.g. liquid filled objects, lighted candles).
- ⑰ This product may contain lead and mercury. Disposal of these materials may be regulated due to environmental considerations. For disposal or recycling information, please contact your local authorities or the Electronic Industries Alliance: www.eiae.org.
- ⑱ Where the MAINS plug or an appliance coupler is used as the disconnect device, the disconnect device shall remain readily operable.

**Warning**

- Never remove the casing of this apparatus.
- Never lubricate any part of this apparatus.
- Never place this apparatus on other electrical equipment.
- Keep this apparatus away from direct sunlight, naked flames or heat.
- Never look into the laser beam inside this apparatus.
- Ensure that you always have easy access to the power cord, plug or adaptor to disconnect this apparatus from the power.

Hearing safety**Listen at a moderate volume.**

- Using headphones at a high volume can impair your hearing. This product can produce sounds in decibel ranges that may cause hearing loss for a normal person, even for exposure less than a minute. The higher decibel ranges are offered for those that may have already experienced some hearing loss.
- Sound can be deceiving. Over time your hearing 'comfort level' adapts to higher volumes of sound. So after prolonged listening, what sounds 'normal' can actually be loud and harmful to your hearing. To guard against this, set your volume to a safe level before your hearing adapts and leave it there.
- Set your volume control at a low setting.
- Slowly increase the sound until you can hear it comfortably and clearly, without distortion.
- Prolonged exposure to sound, even at normally 'safe' levels, can also cause hearing loss.
- Be sure to use your equipment reasonably and take appropriate breaks.
- Listen at reasonable volumes for reasonable periods of time.
- Be careful not to adjust the volume as your hearing adapts.
- Do not turn up the volume so high that you can't hear what's around you.

- You should use caution or temporarily discontinue use in potentially hazardous situations. Do not use headphones while operating a motorized vehicle, cycling, skateboarding, etc.; it may create a traffic hazard and is illegal in many areas.

Notice

Any changes or modifications made to this device that are not expressly approved by Philips Consumer Lifestyle may void the user's authority to operate the equipment.

Your product is designed and manufactured with high quality materials and components, which can be recycled and reused.



When this crossed-out wheeled bin symbol is attached to a product it means that the product is covered by the European Directive 2002/96/EC.



Please inform yourself about the local separate collection system for electrical and electronic products.

Please act according to your local rules and do not dispose of your old products with your normal household waste. Correct disposal of your old product helps to prevent potential negative consequences for the environment and human health.

Your product contains batteries covered by the European Directive 2006/66/EC, which cannot be disposed with normal household waste. Please inform yourself about the local rules on separate collection of batteries because correct disposal helps to prevent negative consequences for the environmental and human health.

**Environmental information**

All unnecessary packaging has been omitted. We have tried to make the packaging easy to separate into three materials: cardboard (box),

polystyrene foam (buffer) and polyethylene (bags, protective foam sheet.)

Your system consists of materials which can be recycled and reused if disassembled by a specialized company. Please observe the local regulations regarding the disposal of packaging materials, exhausted batteries and old equipment.

This apparatus includes this label:



Class II equipment symbol



This symbol indicates that the unit has a double insulation system.



Windows Media and the Windows logo are trademarks, or registered trademarks of Microsoft Corporation in the United States and/or other countries.

2 Your Micro Hi-Fi System

Congratulations on your purchase, and welcome to Philips! To fully benefit from the support that Philips offers, register your product at www.philips.com/welcome.

Introduction

With this unit, you can enjoy audio from discs, USB devices, iPod players, iPhone and other external devices, or listen to radio stations. The unit offers Digital Sound Control (DSC) and Dynamic Bass Boost (DBB) to enrich sound. The unit supports the following media formats:



What's in the box

Check and identify the contents of your package:

- Main unit
- Remote control
- Power adaptor
- 1 x MP3 link cable
- Mounting kit (2 dowels and 2 screws)
- Quick start guide
- User manual
- Wall mounting instructions

Overview of the main unit

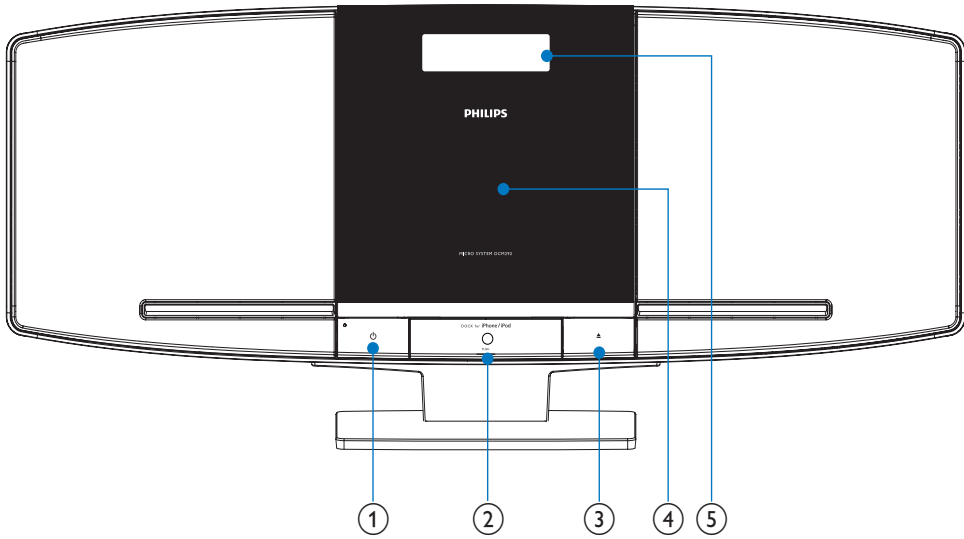

- ①
 - Turn on the unit, or switch to standby mode.
- ② Dock for iPod/iPhone
- ③
 - Open/close the disc compartment.
- ④ Disc compartment
- ⑤ Display panel
 - Show current status.

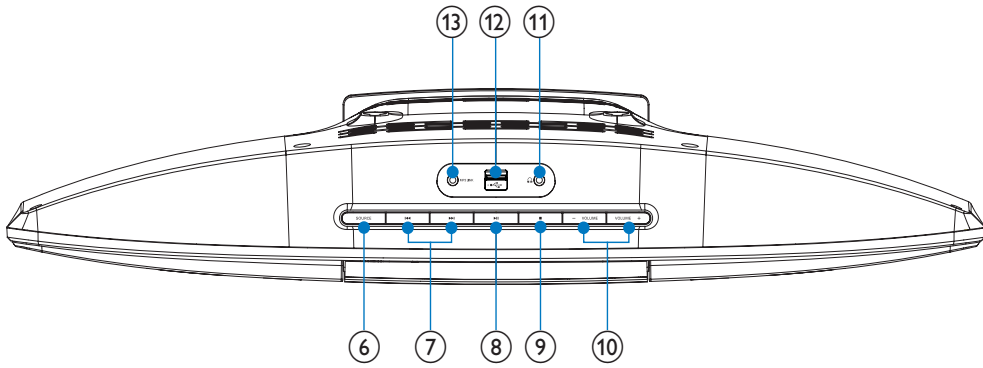

- ⑥ **SOURCE**
- Select a source: CD, FM tuner, USB, iPod, or MP3 link.
- ⑦ **⏮️⏪️⏩️⏭️**
- Skip to the previous/next track.
 - Search within a track.
 - Tune to a radio station.
 - Adjust hour/minute digits.
 - Select 12 hour or 24 hour format.
- ⑧ **▶️⏸️**
- Start or pause play.
- ⑨ **■**
- Stop play or erase a program.
- ⑩ **VOLUME + / -**
- Adjust volume.
- ⑪ **🎧**
- Jack for the headphone.
- ⑫ **🔌**
- Jack for a USB mass storage device.
- ⑬ **MP3 LINK**
- Audio input jack (3.5mm) for an external audio device.

Overview of the remote control

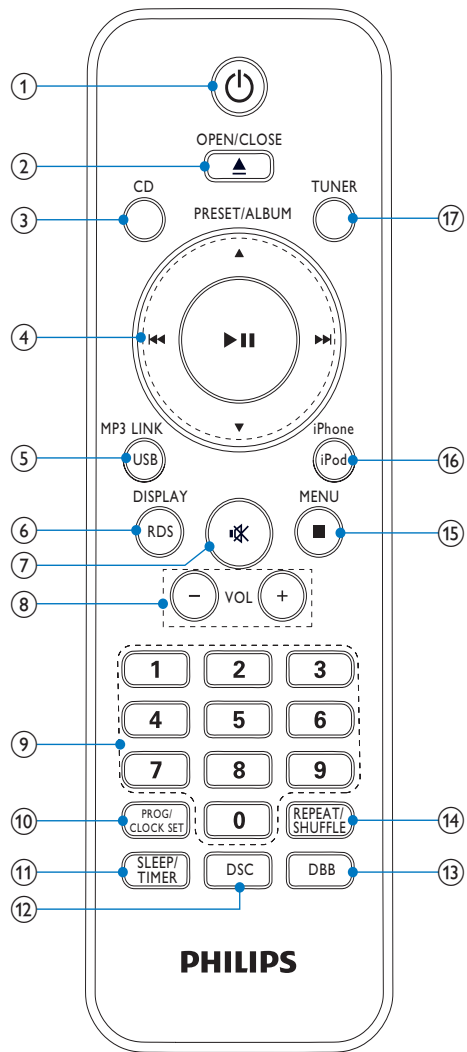

- ① **⏻**
- Turn on the unit, or switch to standby mode.
- ② **OPEN/CLOSE▲**
- Open or close the disc compartment.

- ③ **CD**
 - Select disc source.
- ④ **▲/▼/◀/▶**
 - Navigate in the iPod menu.
 - Skip to the previous/next album.
- ◀◀/▶▶**
 - Skip to the previous/next track.
 - Search within a track.
 - Tune to a radio station.
 - Adjust hour/minute digits.
 - Select 12 hour or 24 hour format.
- ▶||**
 - Start or pause play.
- ⑤ **USB/MP3 LINK**
 - Select USB device source.
 - Select external audio device source.
- ⑥ **RDS/DISPLAY (RDS not available)**
 - Select display information during play.
- ⑦ **🔇**
 - Mute or restore volume.
- ⑧ **VOL +/-**
 - Adjust volume.
- ⑨ **Numeric keypad**
 - Select a track from a disc directly.
 - Select a preset radio station.
- ⑩ **PROG/CLOCK SET**
 - Program tracks.
 - Program radio stations.
 - Scan for radio stations automatically.
 - Set the clock.
- ⑪ **SLEEP/TIMER**
 - Set the sleep timer.
 - Set the alarm timer.
- ⑫ **DSC**
 - Select a preset sound setting.
- ⑬ **DBB**
 - Turn on or off dynamic bass enhancement.
- ⑭ **REPEAT/SHUFFLE**
 - Play a track or all tracks repeatedly.
 - Play tracks randomly.
- ⑮ **■/MENU**
 - Stop play or erase a program.
 - Access the iPod menu.
- ⑯ **iPod/iPhone**
 - Select iPod/iPhone source.
- ⑰ **TUNER**
 - Select tuner source.

3 Get started

! Caution

- Use of controls or adjustments or performance of procedures other than herein may result in hazardous radiation exposure or other unsafe operation.

Always follow the instructions in this chapter in sequence.

If you contact Philips, you will be asked for the model and serial number of this apparatus. The model number and serial number are on the rear of the apparatus. Write the numbers here:
Model No. _____
Serial No. _____

Placement

You can place the unit on a flat surface or mount the unit on a wall.

Mount on a wall

To wall mount the unit, see the included separate sheet of wall mounting instructions.

Prepare the remote control

! Caution

- Risk of explosion! Keep batteries away from heat, sunshine or fire. Never discard batteries in fire.

To insert the remote control battery:

- 1 Open the battery compartment.
- 2 Insert 2 AAA batteries (not supplied) with correct polarity (+/-) as indicated.
- 3 Close the battery compartment.

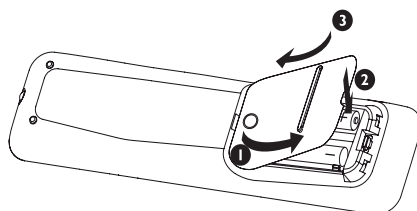

≡ Note

- If you are not going to use the remote control for a long time, remove the batteries.
- Do not use old and new or different types of batteries in combination.
- Batteries contain chemical substances, so they should be disposed of properly.

Connect power

! Caution

- Risk of product damage! Ensure that the power voltage corresponds to the voltage printed on the back or underside of the apparatus.

! Warning

- Risk of electric shock! When you unplug the AC adaptor, always pull the plug from the socket. Never pull the cord.

! Caution

- Before connecting the AC adaptor, ensure you have completed all other connections.

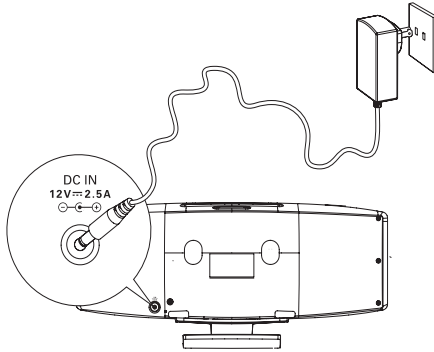

- 1 Connect the power adaptor to:
 - the DC IN jack on the main unit.
 - the wall outlet.

Auto install radio stations

When you connect power and no radio stations are stored, the unit automatically begins to store radio stations.

- 1 Connect the unit to the power supply.
 - ↳ [AUTO INSTALL PRESS -- PLAY KEY] (auto install press -- play key) is displayed.
- 2 Press ►|| on the main unit to start installation.
 - ↳ The unit automatically stores radio stations with sufficient signal strength.
 - ↳ When all the available radio stations are stored, the first preset radio station is broadcast automatically.

Set clock

Note

- You can set the clock in the standby mode only.

- 1 Press and hold **PROG/CLOCK SET** to enter the clock setting mode.
 - ↳ [SET CLOCK] (set clock) scrolls on the screen.
- 2 Press ◀◀▶▶ repeatedly to select 12 hour or 24 hour format.
- 3 Press **PROG/CLOCK SET** to confirm.
 - ↳ The hour digits are displayed and begin to blink.
- 4 Press ◀◀▶▶ to set the hour.
- 5 Press **PROG/CLOCK SET** to confirm.
 - ↳ The minute digits are displayed and begin to blink.
- 6 Press ◀◀▶▶ to set the minute.
- 7 Press **PROG/CLOCK SET** to confirm the clock setting.

Turn on

- 1 Press ⏻.
 - ↳ The unit switches to the last selected source.

Switch to standby

- 1 Press ⏻ again to switch the unit to standby mode.
 - ↳ The clock (if set) appears on the display panel.

4 Play

Play a disc

- 1 Press **CD** to select the disc source.
- 2 Press **▲** to open the disc compartment.
- 3 Insert a disc with the printed side facing outward.
- 4 Press **▲** to close the disc compartment.
↳ Play starts automatically. If not, press **▶||**.

Play from USB

Note

- Ensure that the USB device contains playable audio content.

- 1 Insert the USB device into the  socket.

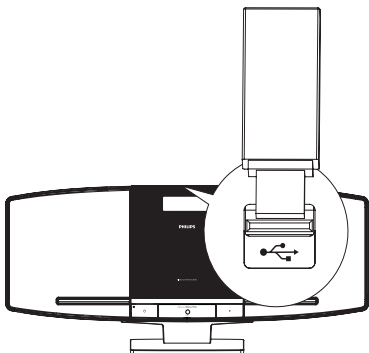

- 2 Press **USB** to select the USB source.
↳ Play starts automatically. If not, press **▶||**.
 - To select a folder, press **▲/▼**.
 - To select an audio file, press **◀◀▶▶▶**.

Play iPod/iPhone

You can enjoy audio from iPod/iPhone through this Micro Hi-Fi system.

Compatible iPod/iPhone

Apple iPod and iPhone models with a 30-pin dock connector:

- iPod classic, iPod touch, iPod nano, iPod 5th generation (video), iPod with color display, iPod mini
- iPhone, iPhone 3G, iPhone 3GS

Play an iPod/iPhone player

Note

- When an iPod/iPhone player is loaded, the unit switches to iPod source automatically.

- 1 Push to open the dock compartment.

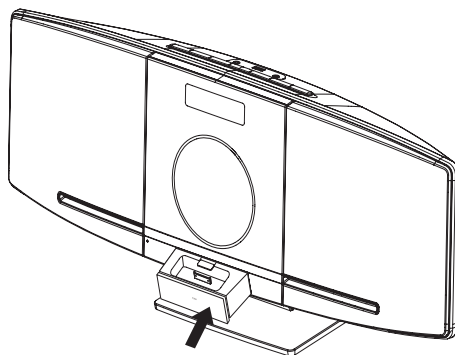

- 2 Place the iPod/iPhone player in the dock.

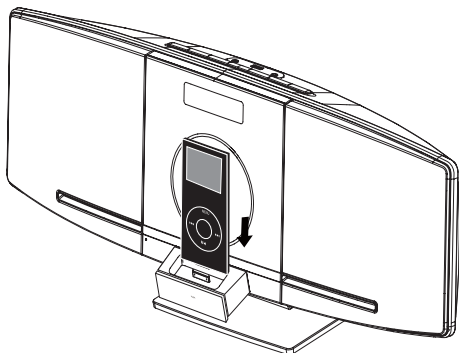

- 3 Press **iPod** to select iPod source.
 - ↳ The connected iPod/iPhone plays automatically.
 - To pause/resume play, press **▶||**.
 - To skip to a track, press **⏮▶**.
 - To search during play, press and hold **⏮▶**, then release to resume normal play.

Charge the iPod/iPhone

When the unit is connected to power, the docked iPod/iPhone begins to charge.

5 Listen to radio

Tune to a radio station

- 1 Press **TUNER** to select FM.
- 2 Press and hold **⏮▶** for more than 2 seconds.
 - ↳ **[SEARCH]** (search) is displayed.
 - ↳ The radio tunes to a station with strong reception automatically.
- 3 Repeat step 2 to tune to more stations.
 - To tune to a weak station, press **⏮▶** repeatedly until you find optimal reception.

Program radio stations automatically

You can program a maximum of 20 preset radio stations (FM).

- 1 In the tuner mode, press and hold **PROG/CLOCK SET** for more than 2 seconds to activate automatic program mode.
 - ↳ **[AUTO]** (auto) is displayed.
 - ↳ All available stations are programmed in the order of waveband reception strength.
 - ↳ The first programmed radio station is broadcast automatically.

Program radio stations manually

You can program a maximum of 20 preset radio stations (FM).

- 1 Tune to a radio station.
- 2 Press **PROG/CLOCK SET** to activate program mode.
 - ↳ **[PROG]** (program) is displayed.

- 3 Press ▲/▼ to allocate a number to this radio station, then press **PROG/CLOCK SET** to confirm.
- 4 Repeat the above steps to program other stations.



Tip

- To overwrite a programmed station, store another station in its place.

Select a preset radio station

- 1 In tuner mode, press ▲/▼ to select a preset number.
 - You can also press the numeric buttons to select a preset number directly.



Tip

- Position the antenna as far as possible from TV, VCR or other radiation source.
- For optimal reception, fully extend and adjust the position of the antenna.

6 Play options

Pause/resume play

- 1 During play, press ►|| to pause/resume play.

Skip to a track

For CD:

- 1 Press ◀◀▶▶ to select another track.
 - To select a track directly, you can also press a key on the numerical keypad.
- 2 Press ▲/▼ to select an album or a folder.
- 3 Press ◀◀▶▶ to select a track or a file.

Search within a track

- 1 During play, press and hold ◀◀▶▶.
- 2 Release to resume normal play.

Select repeat/shuffle play options

- 1 During play, press **REPEAT/SHUFFLE** repeatedly to select a repeat option or the shuffle play mode.
 - [REPEAT]: the current track is played repeatedly.
 - [REPEAT ALL]: all tracks are played repeatedly.
 - [REPEAT ALB]: all tracks in this album are played repeatedly.
 - [SHUFFLE]: all tracks are played randomly.
- 2 To resume normal play, press **REPEAT/SHUFFLE** repeatedly until no option is displayed.

Program tracks

Note

- You can program tracks only when the play stops.

You can program a maximum of 40 tracks.

- 1 Press **PROG/CLOCK SET** to activate the program mode.
↳ **[PROG]** (program) is displayed.
- 2 For MP3/WMA tracks, press **▲▼** to select an album.
- 3 Press **◀▶** to select a track, then press **PROG/CLOCK SET** to confirm.
- 4 Repeat steps 2 to 3 to program more tracks.
- 5 Press **▶||** to play the programmed tracks.
↳ During play, **[PROG]** (program) is displayed.
 - To erase the program, in the stop position, press **■**.

Display time

- 1 Press **DISPLAY** to display time.

Tip

- In Eco Standby mode, time is displayed for 90 seconds.

Adjust volume level

- 1 During play, press **VOL +/-** to increase/decrease the volume level.

Mute sound

- 1 During play, press **⌘** to mute/unmute sound.

Select a preset sound effect

- 1 During play, press **DSC** repeatedly to select:
 - **[POP]** (pop)
 - **[JAZZ]** (jazz)
 - **[ROCK]** (rock)
 - **[CLASSIC]** (classic)
 - **[FLAT]** (flat - all equalizers off)

Enhance bass

- 1 During play, press **DBB** to turn on or off dynamic bass enhancement.
↳ If DBB is activated, **[DBB]** is displayed.

7 Other features

Set the alarm timer

This unit can be used as an alarm clock. The disc/radio/USB/iPod is activated to play at a preset time.



Note

- Ensure that you have set the clock correctly.

- 1 Press **⏻** to switch to standby mode.
- 2 Press and hold **SLEEP/TIMER** for more than two seconds.
 - ↳ A prompt to select the source is displayed.
- 3 Press **CD**, **TUNER**, **USB** or **iPod** to select a source.
- 4 Press **SLEEP/TIMER** to confirm.
 - ↳ The clock digits are displayed.
 - ↳ The hour digits begin to blink.
- 5 Press **⏮**/**⏭** to set the hour.
- 6 Press **SLEEP/TIMER** to confirm.
 - ↳ The minute digits begin to blink.
- 7 Press **⏮**/**⏭** to set the minute.
 - ↳ The timer is set and activated.
 - ↳ **⌚** is displayed.

Set the sleep timer

This unit can switch to standby automatically after a set period of time.

- 1 When the unit is turned on, press **SLEEP/TIMER** repeatedly to select a set period of time (in minutes).
 - ↳ When sleep timer is activated, **zz** is displayed.

- 2 Press **SLEEP/TIMER** repeatedly until **[OFF]** (off) is displayed.
 - ↳ When sleep timer is deactivated, **zz** disappears on the display.

Play from an external device

You can also listen to an external audio device through this unit.

- 1 Press **USB/MP3 LINK** to select the MP3 link source.
- 2 Connect the supplied MP3 link cable to:
 - The **MP3 LINK** jack (3.5mm) on the unit.
 - The headphone jack on an external device.
- 3 Start to play the device (see the device user manual).

8 Product information



Note

- Product information is subject to change without prior notice.

Specifications

Amplifier

Total output power	2 x 10 W RMS
Frequency response	80 Hz - 16 kHz, \pm 3 dB
Signal to noise ratio	> 60 dB
MP3 link input	0.5 V RMS 20 k Ω

Disc

Laser type	Semiconductor
Disc diameter	12 cm / 8 cm
Support disc	CD-DA, CD-R, CD-RW, MP3-CD, WMA-CD
Audio DAC	24 Bits / 44.1 kHz
Total harmonic distortion	< 1.5%
Frequency response	60 Hz -16 kHz (44.1 kHz)
Signal to noise ratio	> 55 dBA

Tuner

Tuning range	FM: 87.5 - 108 MHz
Tuning grid	50 KHz
Number of presets	20

Speakers

Speaker impedance	2 x 10 W, 4 Ω
-------------------	----------------------

General information

AC power	100 - 240V~, 50/60Hz Model: AS300-120-CQ250
Operation Power Consumption	15 W
Standby Power Consumption	< 2 W
Eco Power Standby Power Consumption	< 1 W
USB Direct	Version 2.0/1.1
Dimensions	
- Main Unit (W x H x D)	565 x 245 x 104 mm
Weight	
- Main Unit	2.7 kg

USB playability information

Compatible USB devices:

- USB flash memory (USB 2.0 or USB 1.1)
- USB flash players (USB 2.0 or USB 1.1)
- memory cards (requires an additional card reader to work with this unit)

Supported formats:

- USB or memory file format FAT12, FAT16, FAT32 (sector size: 512 bytes)
- MP3 bit rate (data rate): 32-320 Kbps and variable bit rate
- WMA v9 or earlier
- Directory nesting up to a maximum of 8 levels
- Number of albums/ folders: maximum 99
- Number of tracks/titles: maximum 999
- ID3 tag v2.0 to v2.3
- File name in Unicode UTF8 (maximum length: 128 bytes)

Supported MP3 disc formats

- ISO9660, Joliet
- Maximum title number: 999 (depending on file name length)
- Maximum album number: 99
- Supported sampling frequencies: 32 kHz, 44.1 kHz, 48 kHz
- Supported Bit-rates: 32-320 (kbps), variable bit rates
- ID3 tag v2.0 to v2.3
- Directory nesting up to a maximum of 8 levels

Maintenance

Clean the cabinet

- Use a soft cloth slightly moistened with a mild detergent solution. Do not use a solution containing alcohol, spirits, ammonia or abrasives.

Clean discs

- When a disc becomes dirty, clean it with a cleaning cloth. Wipe the disc from the centre out.
- Do not use solvents such as benzene, thinner, commercially available cleaners, or antistatic spray intended for analogue records.



Clean the disc lens

- After prolonged use, dirt or dust may accumulate at the disc lens. To ensure good play quality, clean the disc lens with Philips CD lens cleaner or any commercially available cleaner. Follow the instructions supplied with cleaner.

9 Troubleshooting

Warning

- Never remove the casing of this apparatus.

To keep the warranty valid, never try to repair the system yourself.

If you encounter problems when using this apparatus, check the following points before requesting service. If the problem remains unsolved, go to the Philips web site (www.philips.com/welcome). When you contact Philips, ensure that the apparatus is nearby and the model number and serial number are available.

No power

- Ensure that the AC power plug of the unit is connected properly.
- Ensure that there is power at the AC outlet.
- To save power, the unit switches to Eco Standby mode automatically after 15 minutes in standby mode.

No sound

- Adjust the volume.

No response from the unit

- Disconnect and reconnect the AC power plug, then turn on the unit again.

No disc detected

- Insert a disc.
- Check if the disc is inserted with the print side facing inward.
- Wait until the moisture condensation at the lens has cleared.
- Replace or clean the disc.
- Use a finalized CD or correct format disc.

Remote control does not work

- Before pressing any function button, first select the correct source with the remote control instead of the main unit.
- Reduce the distance between the remote control and the unit.

- Insert the battery with its polarities (+/– signs) aligned as indicated.
- Replace the battery.
- Aim the remote control directly at the sensor on the front of the unit.

Cannot display some files in USB device

- The number of folders or files in the USB device has exceeded a certain limit. This phenomenon is not a malfunction.
- The formats of these files are not supported.

USB device not supported

- The USB device is incompatible with the unit. Try another one.

Poor radio reception

- Increase the distance between the unit and your TV or VCR.
- Fully extend and adjust the FM antenna.

Clock/timer setting erased

- Power has been interrupted or the power cord has been disconnected.
- Reset the clock/timer.

Timer does not work

- Set the clock correctly.
- Switch on the timer.

