

Register your product and get support at
www.philips.com/welcome

AZ1027



EN User manual

PHILIPS



© 2010 Koninklijke Philips Electronics N.V.

All rights reserved.

AZ1027_96_UM_V1.1



1 Important

Safety

Important Safety Instructions

- ① Read these instructions.
- ② Keep these instructions.
- ③ Heed all warnings.
- ④ Follow all instructions.
- ⑤ Do not use this apparatus near water.
- ⑥ Clean only with dry cloth.
- ⑦ Do not block any ventilation openings. Install in accordance with the manufacturer's instructions.
- ⑧ Do not install near any heat sources such as radiators, heat registers, stoves, or other apparatus (including amplifiers) that produce heat.
- ⑨ Protect the power cord from being walked on or pinched, particularly at plugs, convenience receptacles, and the point where they exit from the apparatus.
- ⑩ Only use attachments/accessories specified by the manufacturer.

- ⑪ Use only with the cart, stand, tripod, bracket, or table specified by the manufacturer or sold with the apparatus. When a cart is used, use caution when moving the cart/ apparatus combination to avoid injury from tip-over.



- ⑫ Unplug this apparatus during lightning storms or when unused for long periods of time.
- ⑬ Refer all servicing to qualified service personnel. Servicing is required when the apparatus has been damaged in any way, such as power-supply cord or plug is damaged, liquid has been spilled or objects have fallen into the apparatus, the apparatus has been exposed to rain or moisture, does not operate normally, or has been dropped.
- ⑭ Battery usage **CAUTION** – To prevent battery leakage which may result in bodily injury, property damage, or damage to the unit:
- Install all batteries correctly, + and - as marked on the unit.
 - Do not mix batteries (old and new or carbon and alkaline, etc.).
 - Remove batteries when the unit is not used for a long time.
- ⑮ Apparatus shall not be exposed to dripping or splashing.
- ⑯ Do not place any sources of danger on the apparatus (e.g. liquid filled objects, lighted candles).
- ⑰ This product may contain lead and mercury. Disposal of these materials may be regulated due to environmental considerations. For disposal or recycling information, please contact your local authorities or the Electronic Industries Alliance: www.eiae.org.



Warning

- Never look into the laser beam inside the product.
- Never lubricate any part of this product.
- Never place this CD Soundmachine on other electrical equipment.
- Keep this product away from direct sunlight, naked flames or heat.
- Never look into the laser beam inside the product.
- Ensure that you always have easy access to the power cord, plug or adaptor to disconnect the CD Soundmachine from the power.

Notice

Any changes or modifications made to this device that are not expressly approved by Philips Consumer Electronics may void the user's authority to operate the equipment.



This product complies with the radio interference requirements of the European Community.

This product complies with the requirements of the following directives and guidelines: 2004/108/EC + 2006/95/EC



Be responsible
Respect copyrights

The making of unauthorized copies of copy-protected material, including computer programs, files, broadcasts and sound recordings, may be an infringement of copyrights and constitute a criminal offence. This equipment should not be used for such purposes. Recording and playback of material might require consent. See Copyright Act 1956 and The Performer's Protection Acts 1958 to 1972.

Recycling



Your product is designed and manufactured with high quality materials and components, which can be recycled and reused. When you see the crossed-out wheel bin symbol attached to a product, it means the product is covered by the European Directive 2002/96/EC:



Never dispose of your product with other household waste. Please inform yourself about the local rules on the separate collection of electrical and electronic products. The correct disposal of your old product helps prevent potentially negative consequences on the environment and human health.

Your product contains batteries covered by the European Directive 2006/66/EC, which cannot be disposed of with normal household waste.

When you see the crossed-out wheel bin symbol with the chemical symbol 'Pb', it means that the batteries comply with the requirement set by the directive for lead:



Please inform yourself about the local rules on separate collection of batteries. The correct disposal of batteries helps prevent potentially negative consequences on the environment and human health.

This CD Soundmachine includes this label:



2 Your CD Soundmachine

Congratulations on your purchase, and welcome to Philips! To fully benefit from the support that Philips offers, register your product at www.philips.com/welcome.

Introduction

With the CD Soundmachine you can play audio discs and listen to FM/MW radio. You can also program the play sequence of tracks. Dynamic Bass Boost (DBB) helps you to maximize music enjoyment.

What's in the box

Check and identify the contents of the package:

- CD Soundmachine
- AC power cord
- User Manual

Overview of the CD Soundmachine

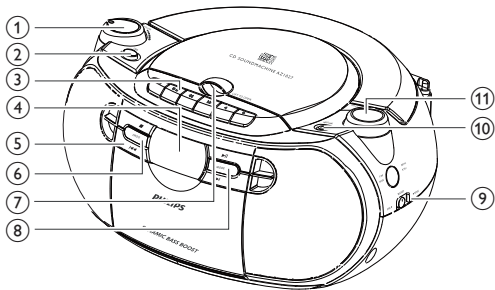

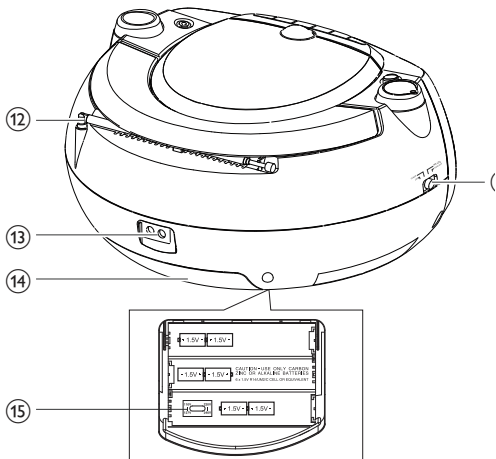

① **VOLUME**

- Adjust volume level

② **DBB**

- Turn the bass enhancement on/off

③ **Cassette recorder buttons**



- Pause play or record



- Stop cassette play or record
- Open the cassette holder



- Fast forward/rewind cassette



- Start cassette play



- Start cassette record

④ Display

⑤ CD Buttons



- Stop CD play
- Erase a CD program



- Start or pause CD play



- Select the previous/next track
- Fast search backward/forward within the current track

⑥ PROG

- Program tracks and browse the program

⑦ LIFT TO OPEN

- Open/Close the CD compartment

⑧ MODE

- Select a play mode: REPEAT or SHUFFLE

⑨ BAND

- Select a wave band

- ⑩ **MP3 LINK**
 - Socket for audio input
- ⑪ **TUNING +/-**
 - Tune to radio stations
- ⑫ **Telescopic antenna**
 - Improve FM reception
- ⑬ **AC MAINS~**
 - Socket for the power cord
- ⑭ **Battery door**
- ⑮ **Voltage Selector**
- ⑯ **Source selector: CD, TUNER, MP3 LINK, TAPE/OFF**
 - Select sound source
 - Switch to standby mode

3 Get started



Caution

- Use of controls or adjustments or performance of procedures other than herein may result in hazardous radiation exposure or other unsafe operation.

Always follow the instructions in this chapter in sequence.

If you contact Philips, you will be asked for the model and serial number of this apparatus. The model number and serial number are on the bottom of the apparatus. Write the numbers here:

Model No. _____

Serial No. _____

Install batteries

- 1 Open the battery compartment.

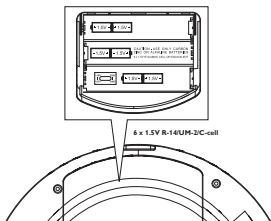

- 2 Insert 6 x 1.5V R14/UM-2/C-cell batteries with correct polarity (+/-) as indicated.
- 3 Close the battery compartment.



Tip

- If you want to save battery life, use the supplied power cord.

Connect AC power



Warning

- Risk of product damage! Ensure that the power supply voltage corresponds to the voltage printed on the back or the underside of the CD Soundmachine.



Note

- Install the unit near the power supply socket and where the AC power plug can be easily reached.

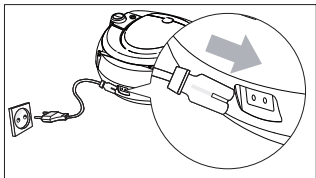

- 1 Connect the power cord to the **AC MAINS~** socket on the CD Soundmachine and to the power supply socket.
 - To switch the CD Soundmachine off completely, disconnect the power cord from the power supply socket.



Tip

- To save energy: After use, set the source selector to **TAPE/OFF**.

4 Use your CD Soundmachine

Play a CD



Note



- You cannot play CDs encoded with copyright protection technologies.

You can play commercially available audio:

- CDs
- CD-Recordables (CD-R)
- CD-Rewritables (CD-RW)

- 1 Switch the source selector to **CD**.
- 2 Lift the lid of the CD compartment.
- 3 Insert a CD with the printed side facing up.
- 4 Close the CD lid gently.
↳ The total number of tracks is displayed.
- 5 Press **▶||** to start play.
↳ [**▶**] is displayed.





- To pause CD play, press .
- To resume CD play, press  again.
- To stop CD play, press .

Select a track

- 1 During play, press  to select a track.

Find a passage within a track

- 1 During play, press and hold .
↳ The CD is played at high speed and with reduced volume.
- 2 Release  to resume normal play.



Tip



- When search reaches the end of the last track, the CD stops.

Program play sequence

You can store up to 20 tracks in the desired sequence.

- 1 In stop mode, press **PROG** to start to program play sequence.
↳ [PROG] and [00] are displayed.



- 2 Press  to select a track.
- 3 Press **PROG** to store the track.
- 4 Repeat steps 2 to 3 to select and store all tracks.
 - ↳ When all 20 tracks are stored, no more tracks can be selected and the display shows [---].
- 5 To play program, press 
 - In stop mode, press **PROG** repeatedly to browse stored tracks.
 - To cancel program, press  twice.





Tip

- When program play stops, the CD Soundmachine returns to normal play. To play program again, repeat steps 1 to 5.

Select play modes

Repeat play

You can repeat a track, a disc, or a program.

-  – plays the current track continuously
-  ALL – repeats the entire CD/program

- 1 During play, press **MODE** repeatedly until the display shows the repeat icon.
 - Repeat one track.



- Repeat the entire CD.



- To stop repeat play, press **MODE** repeatedly until the repeat icon is no longer displayed.

Shuffle play

You can play all tracks in random order.

- 1 During play, press **MODE** repeatedly until the display shows the shuffle icon.



- To stop shuffle play, press **MODE** again.

Listen to radio

- 1 Switch the source selector to **TUNER**.
- 2 Switch **BAND** to **FM** or **MW**.
- 3 Turn **TUNING +/-** to find a station.



Tip

- To improve FM reception, you can extend, incline or turn the telescopic antenna for best reception.
- To improve MW reception, turn the CD Soundmachine to face a different direction.

Play cassette recorder

- 1 Switch the source selector to **TAPE/OFF**.
- 2 Press **■▲** to open the cassette holder, insert a cassette tape, and then close the cassette holder.
- 3 Press **◀** to start play.
 - To pause play, press **||**.
 - To stop the play, press **■▲**.

Find a passage within a tape

- 1 During stop, press **◀◀/▶▶** to search for a desired passage in a tape.
- 2 To stop fast search, press **■▲**.

Record from CD

- 1 Switch the source selector to **CD**.
- 2 Insert a CD with the printed side facing up.
- 3 If you want to record tracks in the desired sequence, program the desired tracks.
- 4 Press **■▲** to open the cassette holder.
- 5 Insert a blank cassette.
- 6 Close the holder.
- 7 Press **●** to start to record.
 - ↳ The disc/program starts automatically from the beginning.
 - To pause, press **||**.
 - To resume, press **||** again.
 - To stop, press **■▲**.

Record from radio

- 1 Switch the source selector to **TUNER**.
- 2 Tune to a radio station.
- 3 Press **■▲** to open the cassette holder.
- 4 Insert a blank cassette.
- 5 Close the holder.
- 6 Press **●** to start to record.
 - To pause, press **||**.
 - To resume, press **||** again.
 - To stop, press **■▲**.

5 Troubleshooting



Warning

- Never remove the casing of this apparatus.

To keep the warranty valid, never try to repair the system yourself. If you encounter problems when using this apparatus, check the following points before requesting service. If the problem remains unsolved, go to the Philips web site (www.Philips.com/support), or contact Philips (see Contact information). When you contact Philips, ensure that the apparatus is nearby and the model number and serial number are available.

No power

- Ensure that the power cord is connected securely.
- Ensure that there is power at the power supply socket.
- Ensure that the batteries are installed correctly.

No sound

- Adjust the volume.
- Ensure that the track played is of a compatible format.

Display does not function properly./No reaction to operation of any of the controls.

- 1 Disconnect the AC power cord.
- 2 Connect the AC power cord after a few seconds.

Cannot play disc

- Ensure that the disc label is inserted with the printed side facing up.
- Wipe the disc with fibre cleaning cloth from the centre to the edge in a straight line.

- This disc may be defective. Play another disc.
- Ensure that the CD is a finalised CD/CD-R/CD-RW.
- Ensure that the laser lens is clean.
- Ensure that the CD is not encoded with copyright protection technologies.

The CD skips tracks

- Ensure that the CD is not damaged or dirty.
- Ensure that program/shuffle mode is deactivated.

Poor cassette sound quality

- Ensure that heads in the cassette holder are clean.
- Ensure that a NORMAL (IECI) cassette tape is used for record.

Cassette does not work for record

- Ensure that cassette tabs are not broken.

6 Product information



Note

- Product information is subject to change without prior notice.

Dimensions (Main unit) (W x H x D)	291 x 146 x 243 mm 11.5 x 5.8 x 9.6 inches
Weight (Main unit)	1.8 kg 3.8 pound
Power supply	DC 9V 1.5 A AC 110V~127V, 220~240 V
Power consumption	Active 12W Standby < 2W
Power output	2 x 1W RMS
Operating temperature range	-10°C - +50°C 14°F - 122°F