

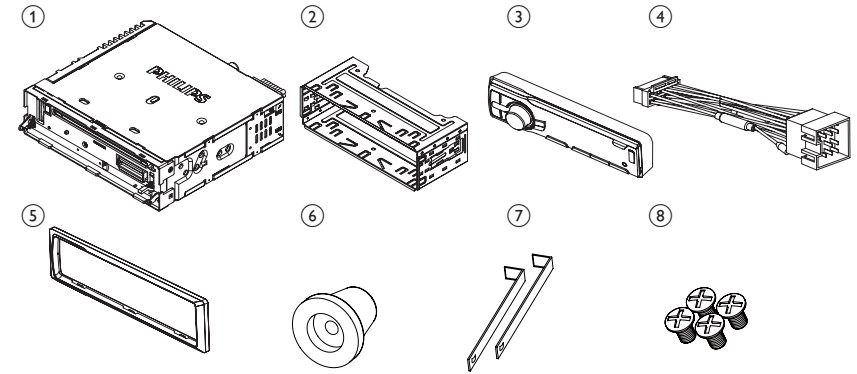

EN Quick Start Guide

1



2

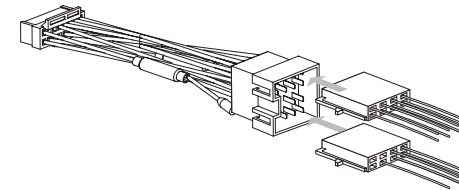

3

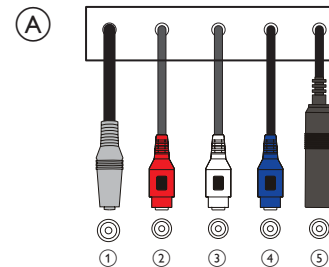

4

B

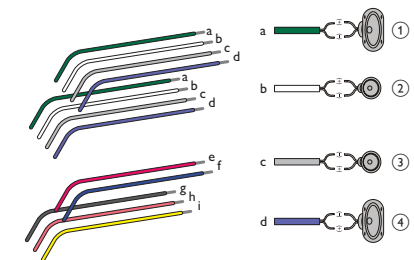

5

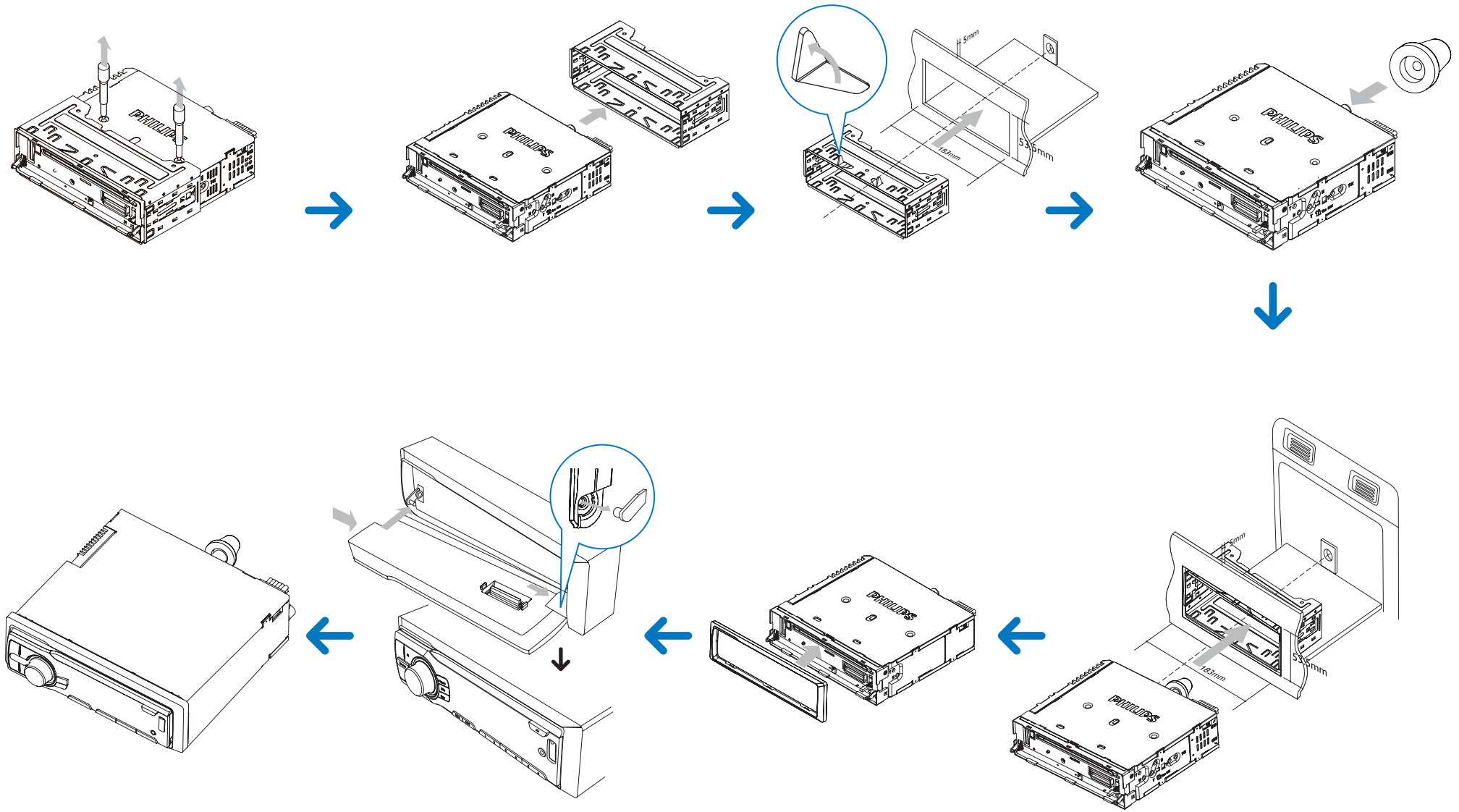

Overview of parts 1

These are the supplied parts needed to connect and install this unit.

- 1 In-car audio system
- 2 Sleeve
- 3 Front panel
- 4 Standard connector
- 5 Trim plate (2 pieces)
- 6 Rubber cushion
- 7 Disassembly tools
- 8 Screws 4 pieces

Connect wires

! Caution

- Ensure that all loose leads are insulated with electrical tape.

For cars with ISO connectors 2 3

- 1 Pull out the ISO connectors from car dashboard and connect them to the bigger end of the supplied standard connector.
- 2 Connect the other end of the supplied standard connector to the unit.
- 3 Connect the antenna and amplifier as illustrated, if applicable.

Connector	Connect to
1 MIC	Microphone
2 REAR LINE OUT R	Rear right speaker
3 REAR LINE OUT L	Rear left speaker
4 SUB OUT	Subwoofer
5 ANTENNA	Antenna

For cars with ISO connectors 3 4

! Caution

- Be sure to connect the black ground (earth) lead first.

- 1 Connect the antenna and amplifier as illustrated, if applicable.
- 2 Cut off the bigger end of the supplied standard connector.
- 3 Check the car's wiring carefully and connect them to the supplied standard connector.
- 4 Connect the supplied standard connector to the unit.

1	Green/black strip	Left speaker (Rear)
2	White/black strip	Left speaker (Front)
3	Gray/black strip	Right speaker (Front)
4	Purple/black strip	Right speaker (Rear)

e RED	Ignition key +12V DC when ON/ACC
f BLUE	Motor/electric antenna relay control lead/ Amplifier relay control lead
g BLACK	Ground
h Orange/white	Illumination switch
i YELLOW	To the +12V car battery which is energized at all times

≡ Note

- Check wire connection before you mount the unit into a car.
- If preset radio stations are lost when the ignition key is turned **OFF** and then back **ON**, reconnect the red leads crosswise to the yellow ones.

Mount in the dashboard 5

- 1 If the car does not have an on-board drive or navigation computer; disconnect the negative terminal of the car battery.
 - If you disconnect the car battery in a car that has an on-board drive or navigation computer; the computer may lose its memory.
 - If the car battery is not disconnected, to avoid short-circuit, ensure that bare wires do not touch each other.
- 2 Remove the two screws on the top of the unit.
- 3 Remove the mounting sleeve with the supplied disassembly tools.
- 4 Install the sleeve into the dashboard and bend the tabs outward to fix the sleeve.
- 5 Place the rubber cushion over the end of the bolt.
- 6 Slide the unit into the dashboard until you hear a click sound.
- 7 Reconnect the negative terminal of the car battery.

Attach the front panel 5

- 1 Attach the trim plate.
- 2 Insert the right side of the panel in the chassis until it is correctly engaged.
- 3 Press the left side of the panel and point the left hole at the left pillar.
- 4 Release the panel to engage the left side.

Turn on

- 1 Press **⏻** to turn on the unit.
 - To turn off the unit, press **⏻** for 3 seconds.

Set clock

- 1 Press **MENU/DISP** for 3 seconds.
- 2 Press **▲** or **▼** repeatedly to until the currently time is displayed.
- 3 Turn **⌚** clockwise to set hour.
- 4 Press **⏻** to confirm.
- 5 Turn **⌚** anti-clockwise to set minute.
- 6 Press **⏻** to confirm.

View clock

- 1 Press **MENU/DISP** repeatedly until the clock is displayed.

Listen to radio

- 1 Press **SOURCE** repeatedly to select Tuner.
- 2 Press **⏻** or **⏮** to select band: **[FM1]**, **[FM2]**, **[FM3]**, **[AM1]**, or **[AM2]**.
- 3 Press **⏮** or **⏭** to tune to a radio station manually.
 - To search for a radio station automatically, press **SEARCH** for 3 seconds.

Pairing bluetooth devices

You can pair your bluetooth device with the unit as follows:

- 1 Turn on bluetooth function on the device.
- 2 Setup bluetooth function on your device.
- 3 Select "CEM250" in the pairing list.
- 4 Enter default password "0000".
↳ "[CONNECT]" is displayed on the panel if pairing succeeds.
- 5 Press and hold **SOURCE** to disconnect Bluetooth connection.

Note

- You can hold **SOURCE** again to reconnect last used Bluetooth device.

Make a call

- 1 Press **SOURCE** repeatedly to select **BT MUSIC**.
- 2 Press **↵**.
- 3 Press **▲** or **▼** to select from the following list:
 - **DIAL NUM**: dial number directly
 - **DIALLED**: dialed number
 - **MISSED**: missed call
 - **RECEIVED**: received call
 - **ME PBK**: Phone directory
 - **SIM PBK**: SIM directory
- 4 Press **⏻** to confirm the selection.

To dial a number directly, select **DIAL NUM**.

- 1 Press 0-9 to enter phone number:
 - Press **⏪** to change a number.
 - Press **⏩** to reset entered numbers.

- 2 Press **↵** to dial.

To use a number in call log or directory, select the option other than **DIAL NUM**.

- 1 Turn **⏻** to select a number from call log or directory.
- 2 Press **↵** to dial.

Terminate call

- ① Press **⏩** to terminate call.



CLASS 1
LASER PRODUCT