

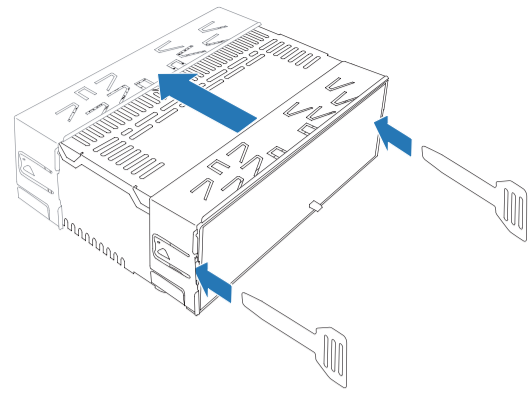

Quick start guide



①



②

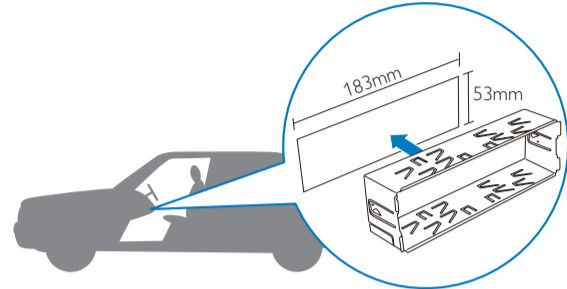

③

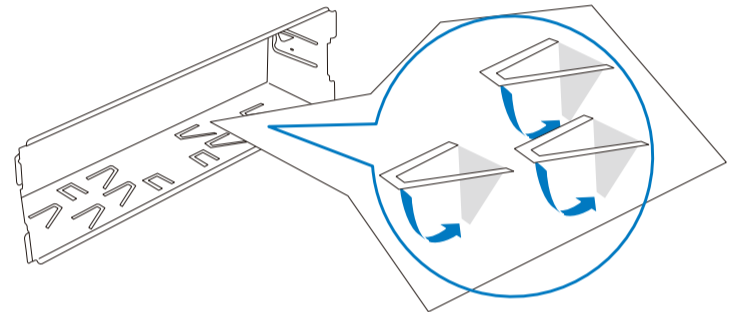

④

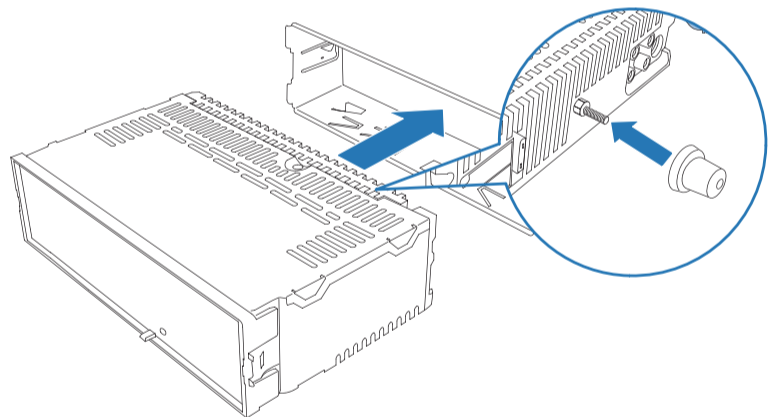

⑤

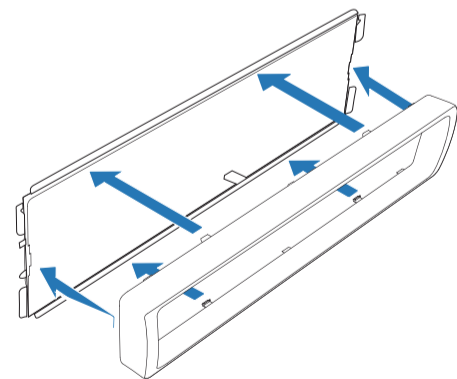

⑥

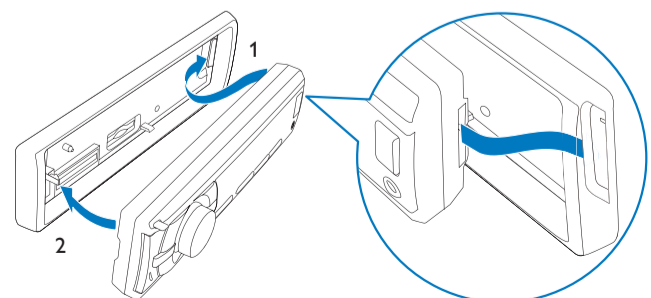

Quick start guide

What's in the box

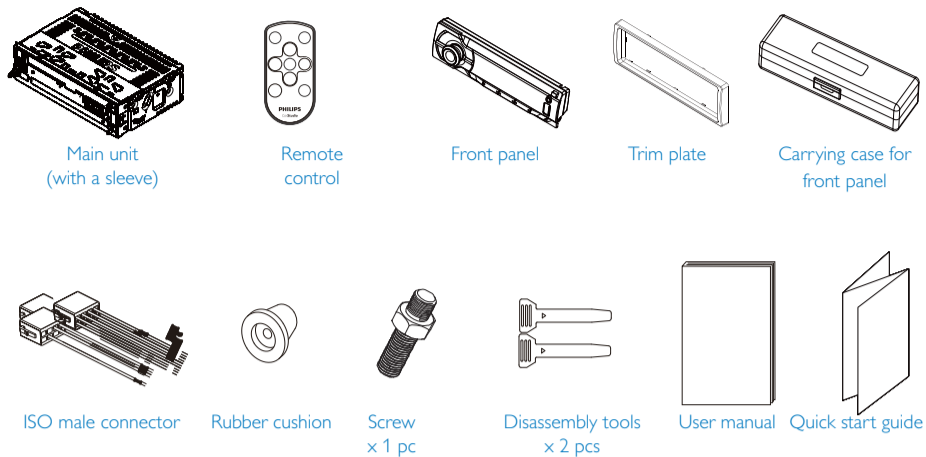

Connection: for cars with ISO connectors

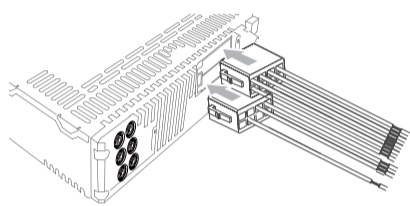

- 1 Connect the supplied male connector to the unit.
- 2 Check the car's wiring carefully and connect them to the the supplied male connector:

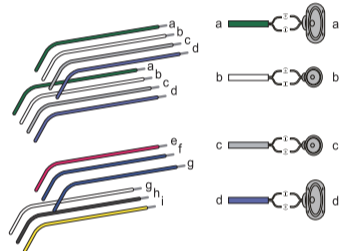

1	Green/black strip	Left speaker (Rear)
2	White/black strip	Left speaker (Front)
3	Gray/black strip	Right speaker (Front)
4	Purple/black strip	Right speaker (Rear)
e	Red	Ignition key +12V DC when ON/ACC
f	Blue	Motor/electric antenna relay control lead
g	Blue/white	Amplifier relay control lead
h	Black	Ground
i	Yellow	To the +12V car battery which is energized at all times

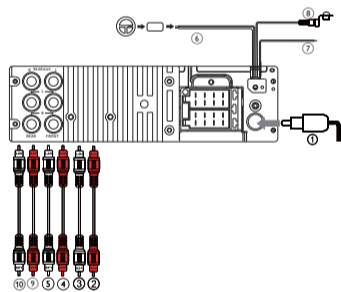

- 3 Connect the antenna and amplifier as illustrated, if applicable.

Connector	Connect to
1 ANTENNA	Antenna
2 FRONT LINE OUT R (Socket)	Front right speaker
3 FRONT LINE OUT L (Socket)	Front left speaker
4 REAR LINE OUT R (Socket)	Rear right speaker
5 REAR LINE OUT L (Socket)	Rear left speaker
6 OE REMOTE (Purple)	OE Remote
7 TEL MUTING (Blue)	To cellular phone system
8 SUBWOOFER (Blue)	Subwoofer
9 REAR AUX LINE OUT R	Rear Aux right
10 REAR AUX LINE OUT L	Rear Aux left

Turn on

To turn on the unit,

- Press \odot .

To turn off the unit,

- press and hold \odot until the unit is turned off.

Select country/region

- 1 Press \odot to turn on the unit.
↳ [SELECT OPERATING REGION] is displayed.

- 2 Rotate \odot to select an option:
 - [USA] (United States)
 - [LATIN] (Latin America)
 - [EUROPE] (Western Europe)
 - [RUS] (Russia)
 - [M-EAST] (Middle East)
 - [ASIA] (Asia Pacific)
 - [JAP] (Japan)
 - [AUST] (Australia)
- 3 Press \odot to confirm.

Set clock

- 1 Press **MENU** repeatedly until current time is flashed.
- 2 Rotate \odot to set hour.
- 3 Press \odot to confirm.
- 4 Rotate \odot to set minute.
- 5 Press \odot to confirm.

Tune to a radio station

- 1 Press **SOURCE** repeatedly to select radio mode.
- 2 Press **BAND** or \blacktriangle / \blacktriangledown repeatedly to select band: [FM1], [FM2], [FM3], [AM1], or [AM2].
- 3 Press and hold \blacktriangleleft or \blacktriangleright until the frequency digit is flashed.
- 4 Press \blacktriangleleft or \blacktriangleright to tune to a radio station manually.
 - ↳ The radio station is broadcast.
 - To search for a radio station automatically, press \blacktriangleleft or \blacktriangleright .

Store stations automatically

- 1 In Radio mode, press and hold **DBB** until [STORE - - -] is displayed.
- 2 Press \odot to confirm.
 - ↳ The six strongest stations of the selected band are saved in preset channel automatically.

Store stations manually

- 1 Tune to a station that you want to store.
- 2 Press a numeric button for 3 seconds.
 - ↳ The station is saved in the selected channel.

Play from USB

- 1 Slide the USB socket cover marked \leftrightarrow to the left.
- 2 Insert the USB device into the USB socket.
 - ↳ The unit starts playing from the USB device automatically.



Connect iPod/iPhone

- 1 Slide the USB socket cover marked \leftrightarrow to the left.
- 2 Insert USB adaptor on one end of iPod/iPhone cable to the USB socket on the main unit.
- 3 Insert the other end of the iPod/iPhone cable to the iPod/iPhone socket.
 - ↳ The unit starts playing from the USB device automatically.

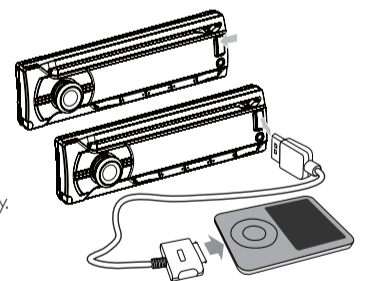

Reset

You can reset the unit to its default setting.

- 1 Detach the front panel.
- 2 Press the reset button by using a ball-point pen or a similar tool.
 - ↳ Preset adjustments such as preset channels and sound adjustments are erased.

