

PHILIPS

WelcomeEye
Look

Home Security Camera



User manual

Register your product at www.philips.com/register

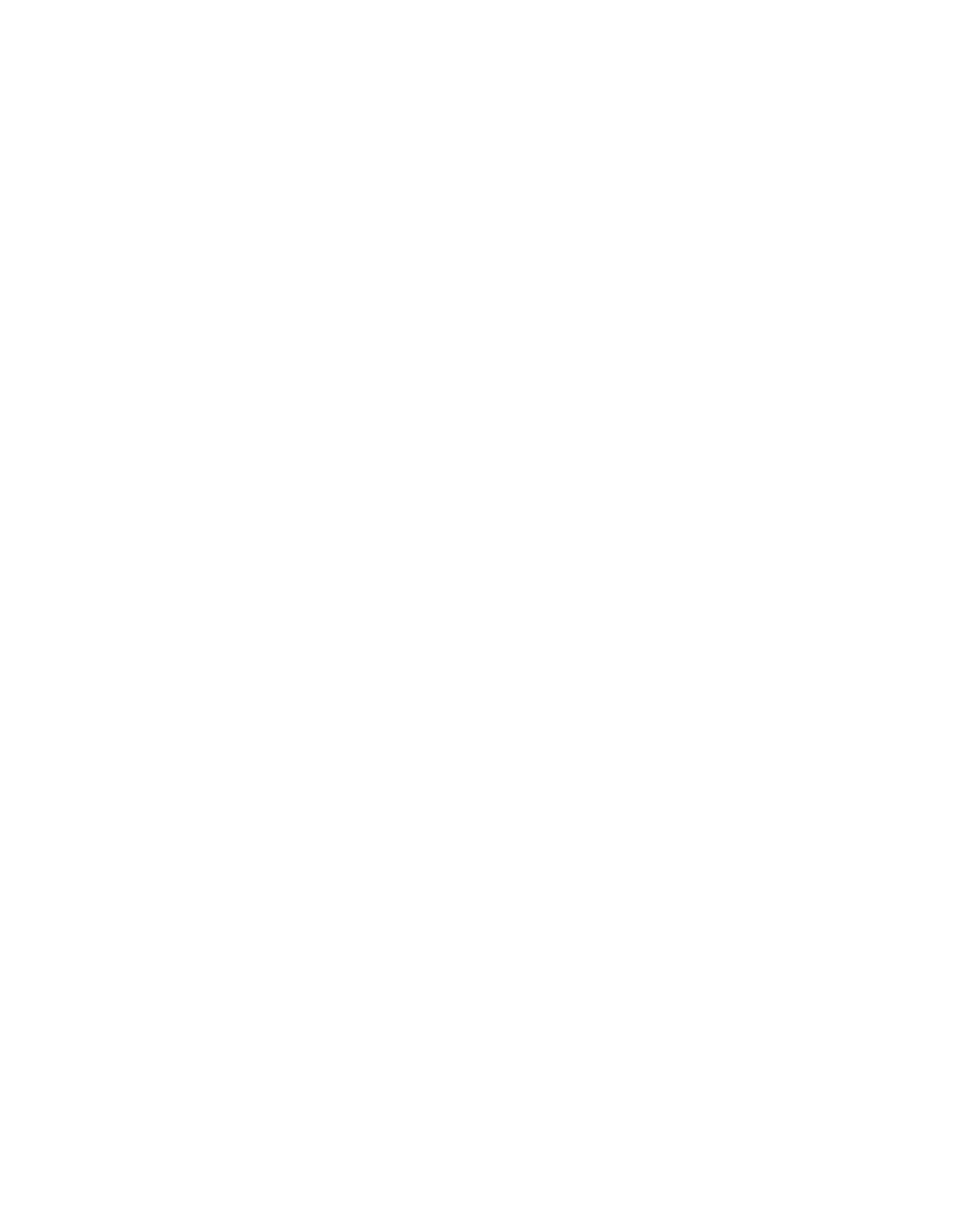

Contents

1. Safety instructions.....	2
2. Contents of the kit.....	2
3. General description.....	3
4. Detailed description.....	3
5. Installing the camera.....	4
5.1. Installing the base	4
5.2. Wiring.....	5
6. Setting up.....	5
6.1. Installation and linking.....	5
6.2. Configuring the camera.....	9
6.3. Detection alert.....	11
6.4. Configuration with voice assistants.....	13
7. Usage.....	14
7.1. Viewing and managing video recordings.....	14
7.2. Viewing live.....	15
8. Technical features.....	16
9. FAQ - Common problems and solutions.....	17
10. Technical support - Warranty.....	18
11. Safety precautions	18
12. FCC/CE warning	19
13. Declaration of Conformity.....	20

1. Safety instructions

Important!

- If you are installing this product for someone else, remember to leave the manual or a copy of it with the end user.

Warning:

- The various components should be dismantled by an authorised technician only.
- The camera uses precision electronics. Avoid moving the camera motor by hand.

Safety precautions:

- To operate this system in complete safety, it is essential that installers, users and technicians follow all the safety procedures described in this manual.
- Specific warnings and warning symbols are given for components where necessary.

2. Contents of the kit

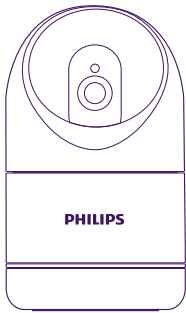

1. Camera



2. Wall plugs for wall-mounting the base (x2)



3. Screws for wall-mounting the base (x2)

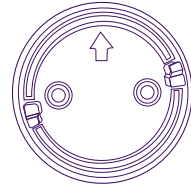

4. Base for ceiling-mounting

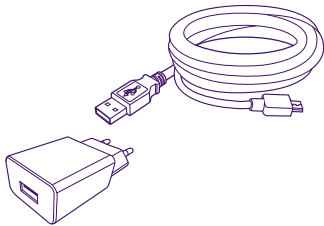

5. Power supply



6. Reset tool



7. 8 GB SD card (pre-inserted in the camera)

3. Overview

This camera is designed to provide security and an indoor monitoring point for users of the Philips WelcomeEye application and ecosystem. Whether you are absent or simply operating it remotely, it enables you to control, dissuade and reassure, whatever the circumstances or lighting conditions.

For effective usage, please carefully read this instruction manual.

4. Detailed description

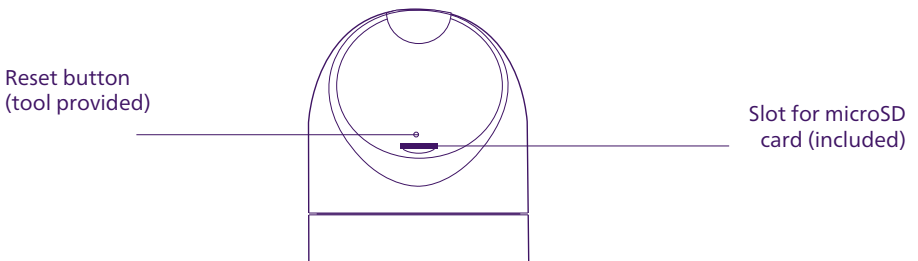
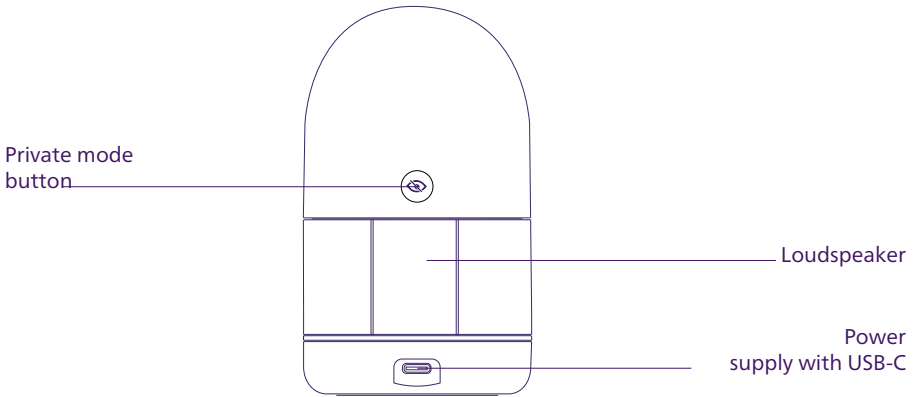
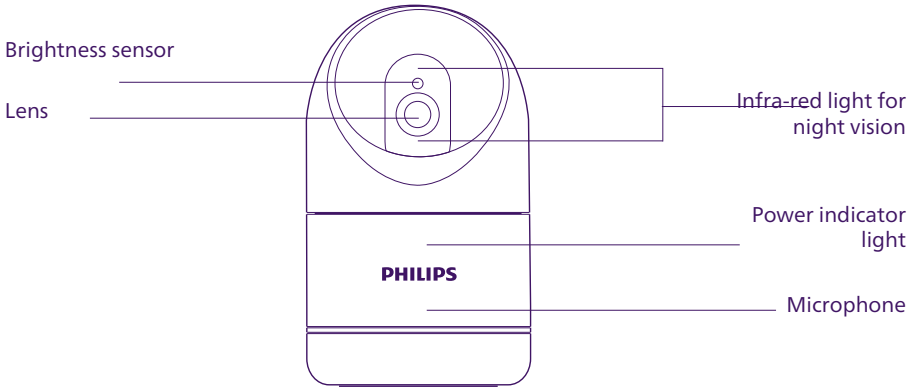

5. Installing the camera

Important notes and advice:

- ⚠ Before installation, you are advised to check that your WiFi network signal is accessible and of sufficient quality in the place where you wish to install your camera.
- The installation and use of the camera must comply with current laws.
- Your camera is exclusively powered by the mains adaptor included, which provides 100-240 VAC 50/60 Hz / 5 VDC 1 A.

5.1. Ceiling mounting (optional)

If you wish to install your Philips WelcomeEye Look camera on the ceiling, the textile-covered front portion of the device can be turned around for aesthetic reasons:

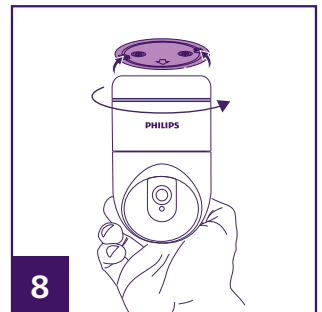
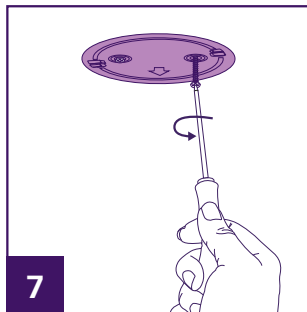
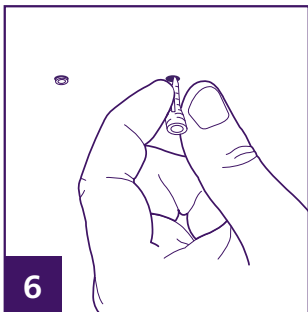
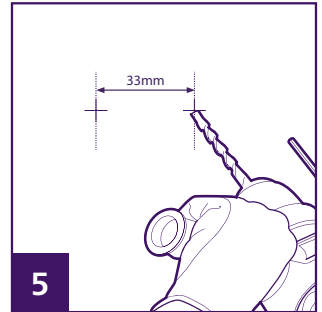
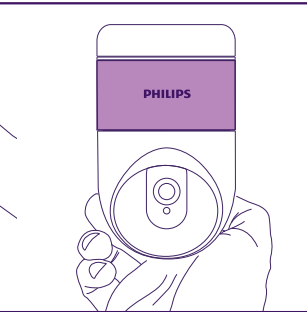
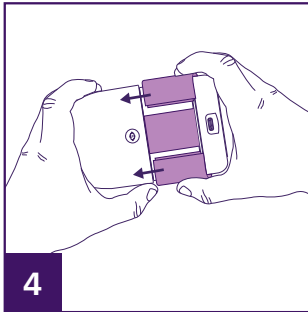
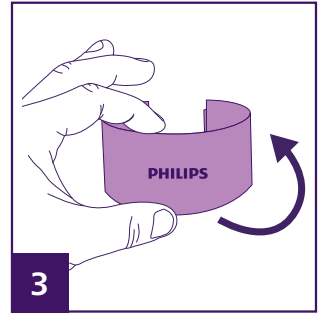
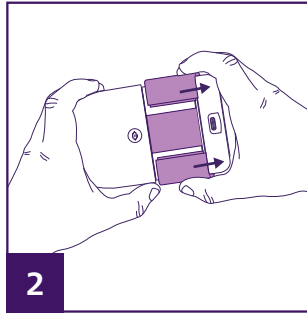
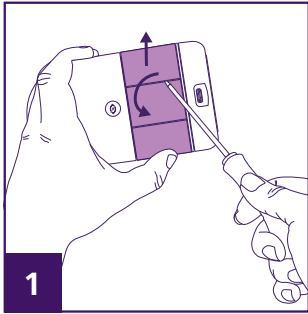

1. Carefully insert a slotted screwdriver into the back of the camera to push the textile-covered front portion outward. Do the same on the other side.

2. Slide the textile-covered front portion downward to completely remove it from the camera.
3. Turn around the textile-covered front portion with the logo.
4. Follow the steps in reverse order to carefully reinstall the textile-covered portion.
5. On the ceiling, mark the location of the 2 holes for the ceiling mounting of your camera. Drill the holes.
6. Insert the wall plugs provided.
7. Attach the base using the 2 screws provided. The screws and plugs supplied are suitable for solid material; you may need to adapt the fastening to your particular substrate.
8. Place the camera on the base and lock it into place by turning it.

5.2. Power supply

Once the camera has been installed (placed on a piece of furniture or mounted on the ceiling), connect the mains adapter to power the device.

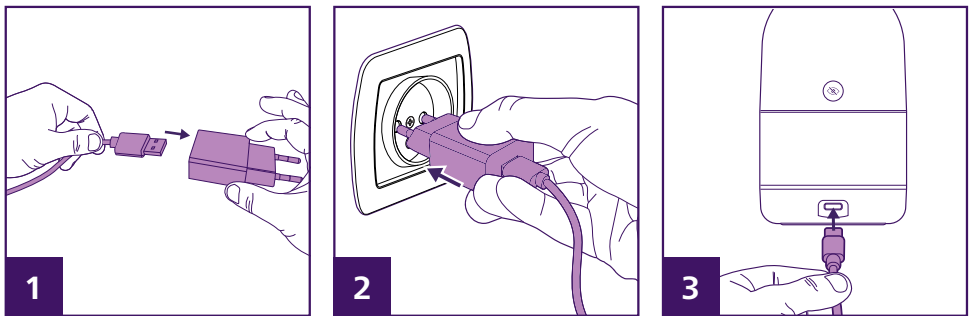

6. Setting up

6.1. Installation and linking

Note: the screenshots below are from the Android version of the application. The iOS version is identical.

Download the **Philips WelcomeEye** application on your iPhone or Android smartphone.



[WelcomeEye for Android](#)



[WelcomeEye for iOS](#)

Then launch the application:

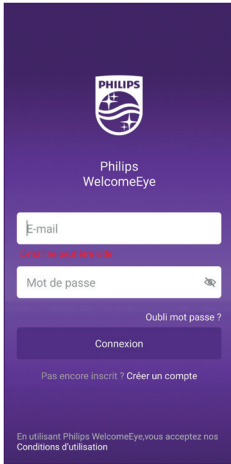

If you don't already have a Philips WelcomeEye account, click on **"Créer un compte" (Create an account)**.

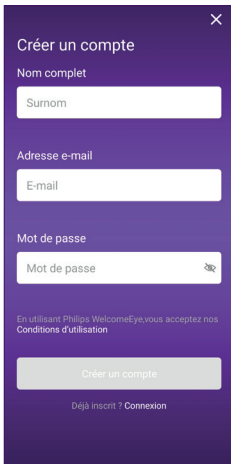

Enter your full name, a valid email address, and the password of your choice, then click on **"Créer un compte" (Create an account)**.

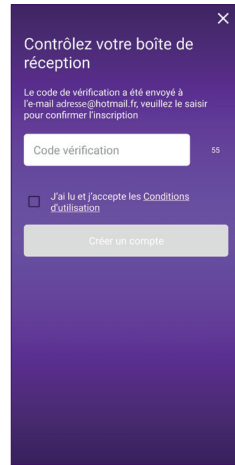

An automatic email is sent to your email address for confirmation.

Enter the 6-digit code provided in the confirmation email to continue, tick the box, then click on **"Créer un compte" (Create an account)**.

If the automatic email is not received after one minute, check the junk mail folder in your mailbox.

Once account creation is complete, click on OK:

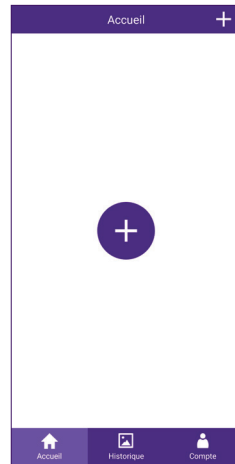

The list of products linked to an account appears.

Click on the **+** icon to continue.

Your Bluetooth must be activated.

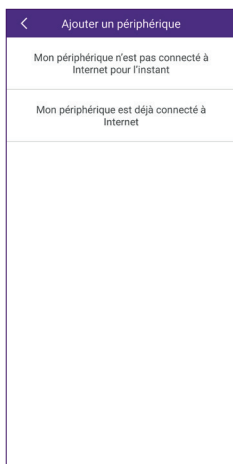

If you have not yet connected the camera to your WiFi network, click on **“Mon périphérique n'est pas connecté à Internet pour l'instant”** (My device is not yet connected to the internet).

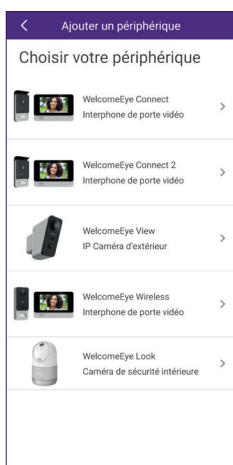

Select the WelcomeEye Look camera from the list of products compatible with the application:



At this point your camera should be powered up and ready to be linked. If not, reset as instructed (by pressing and holding the reset button for 3 seconds until you hear a beep and then a melody) and wait until the camera is ready. The camera emits 2 sets of 5 beeps when it is ready to proceed.

Then click on **“Suivant”** (Next).

Your smartphone will detect nearby devices waiting to be configured. Detection only takes a few seconds, so move closer to the camera if it is not detected by the smartphone.

Important: The application may ask you for access to your smartphone's location. The only reason for this request is that this permission is required to access the list of nearby WiFi networks so that they can be offered to you for use by your camera.

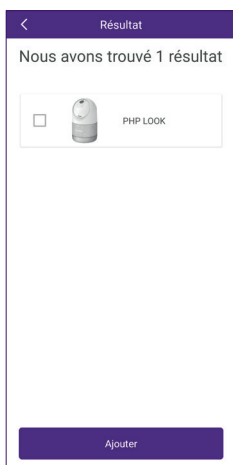

Tick the box for your camera, then click on **"Ajouter"** (Add).

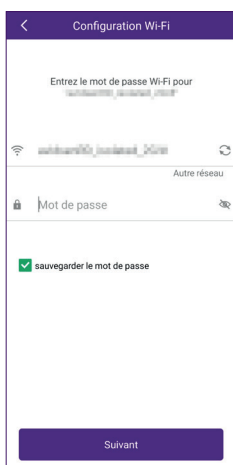

Select the WiFi network that the camera will use and manually enter the WiFi key for your internet box or router. Click on **"Suivant"** (Next).

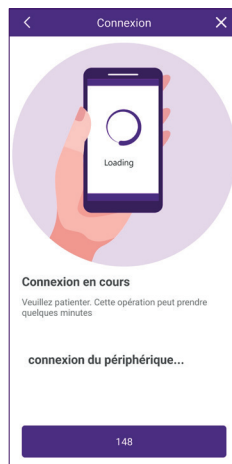

Your smartphone transmits the information to the camera and the camera connects to the Internet. The camera will play a melody indicating that it has received the information from your smartphone.

Important: If a password is entered incorrectly, the camera will make an error noise and restart. Please restart the configuration from the initial step. It will not need to be reset.

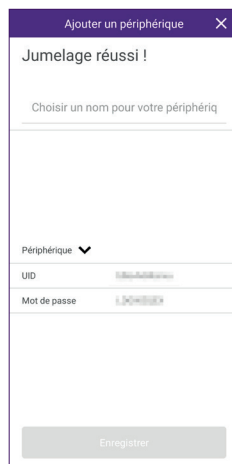

The camera has been detected by your smartphone on the Internet. Enter your name of choice for the camera and click **"Enregistrer"** (Save).

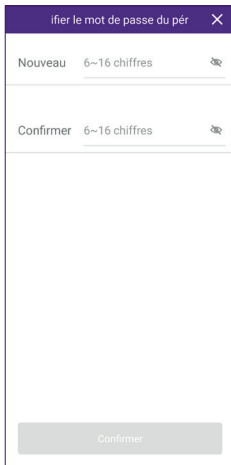

The camera's default login password must be changed before the image can be displayed. Enter a new 6 to 16-digit password and click **"Confirmer" (Confirm)**. The application's home screen is displayed.

6.2. Configuring the camera

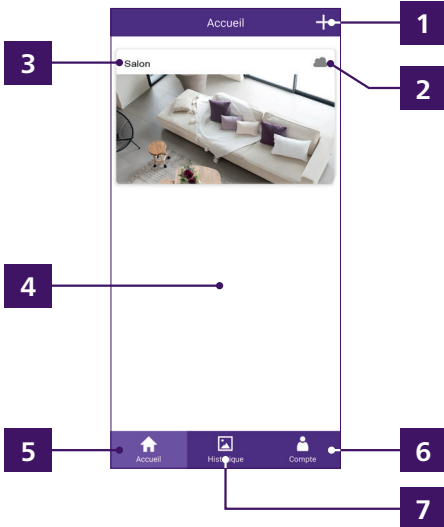

1	Add a new product (another Philips camera or compatible Philips videophone)
2	Camera connection status 👤: online 🚫: offline
3	Camera name
4	If you have another Philips WelcomeEye product, it will also appear on this page
5	List of related products in the app (current screen)
6	Access to account and app options
7	Access to event history

Click on the image to access the camera's live image:

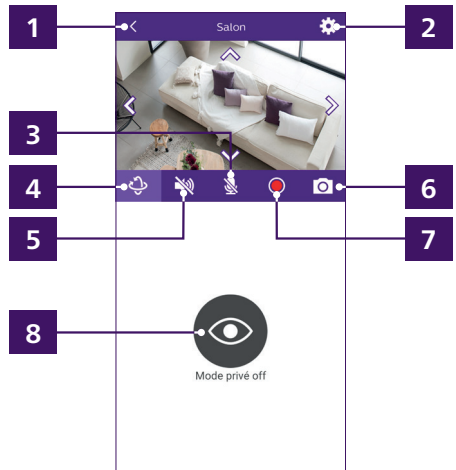

1	Return to previous screen
2	Access to camera settings and options
3	Mute/unmute the smartphone microphone
4	Motor control (displays the up, down, left, and right movement arrows on the image)

5	Mute/unmute the camera microphone
6	Take a photo and save it on your smartphone
7	Start recording live and save to smartphone memory
8	Turn on private mode: Immediately shuts off the microphone and speaker, puts the camera in private mode, and completely covers the lens

8	Settings for video recordings
9	Change the password and set the time
10	Delete the camera from your account

Click on the  icon at the top right of the image to access all the camera options:

Click on  Paramètres avancés to set your camera to the correct time.

The time is displayed on the live image and is also used to date recordings made automatically by the camera:

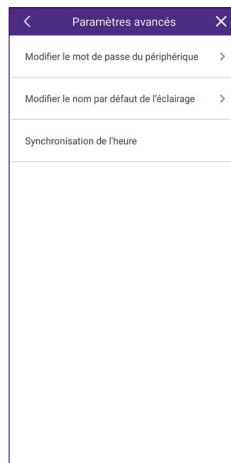

Click on  (Time sync) to copy the time from your smartphone to your camera.

1	Back to the live image
2	Personalised name of the camera
3	Device UID and version
4	Details and formatting of the memory card, reboot the camera
5	Share the camera with other users
6	Video quality
7	Detection settings

6.3. Detection alert

Your camera has two detection systems. Motion detection in its field of vision and recognition of human figures. You can use both independently or simultaneously.

Motion detection settings:

The motion detection settings can be accessed by clicking on  Réglages de l'alarme (Alarm settings) in your camera settings. The camera looks for moving areas in its field of vision and triggers the alert depending on their size.

The sensitivity of the detection is determined by the minimum size of the moving area for the alert to be triggered:

- If sensitivity is low, only significant movements within the camera's field of vision will trigger an alert.
- If sensitivity is high, any motion, no matter how small, will trigger an alert.

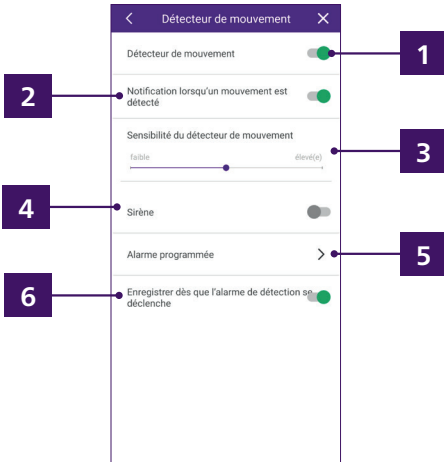

1	Motion detection activation
2	Activation of the notification if movement is detected (you are warned on your smartphone)
3	Detection sensitivity (see above)
4	Siren activation if motion is detected
5	Program activation ranges (see below)
6	Record a video to the memory card if movement is detected

You can activate motion detection manually or automatically by programming times. If you wish to activate automatically according to the time of day, click on  Alarme programmée (Alarm set) and then choose a day of the week:

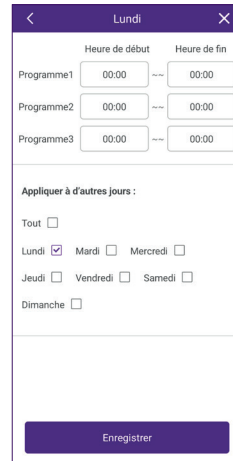

You can define up to 3 time slots with a start and end time for the day, during which the motion detection will be active.

You can also check below if you want to apply the same ranges to all or part of the other days of the week.

Click on **“Enregistrer” (Save)** to finish.
Setting human figure recognition and autotracking:

The human figure recognition settings and the autotracking option can be accessed by clicking on  Réglages de l'alarme (Alarm settings) in your camera settings. The camera searches its field of vision for the contours of moving areas, and triggers the alert depending on their shape.

Detection sensitivity depends on the resemblance to the figure of a human being for an alert to be triggered:

- If sensitivity is low, only a shape very close to a human figure will trigger the alert.
- If sensitivity is high, any shape that more or less resembles a figure will trigger an alert.

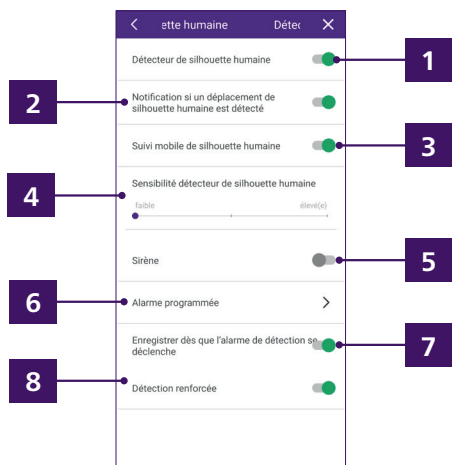

1	Activation of human figure recognition
2	Activation of the notification if a human being is detected (you are warned on your smartphone)
3	Autotracking: the camera moves the motor automatically to follow the detected figure
4	Detection sensitivity (see above)

5	Siren activation if motion is detected
6	Program activation ranges (see below)
7	Record a video to the memory card if movement is detected
8	Activated: With the detection of part of a human figure, an alert will be triggered (recognition of the contours of a face, for example)

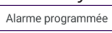
As with motion detection, you can activate human figure recognition manually or automatically by programming times. If you wish to activate automatically according to the time of day, click on  Alarme programmée (Alarm set) and then choose a day of the week:

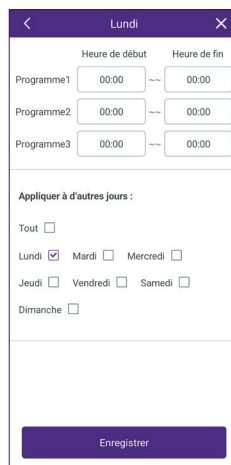

You can define up to 3 time slots with a start and end time for the day, during which the motion detection will be active. You can also check below if you want to apply the same ranges to all or part of the other days of the week. Click on **“Enregistrer” (Save)** to finish.

6.4. Configuration with voice assistants

Your WelcomeEye Look camera is compatible with Alexa and Google Assistant voice assistants.

For example, you can display your camera's image if your voice assistant has a screen, or control the turning on and off of lights if you have connected a light to your camera.

Alexa: Go to the Alexa application and install the "Philips WelcomeEye" skill. Then enter the email address of your WelcomeEye account and its password.

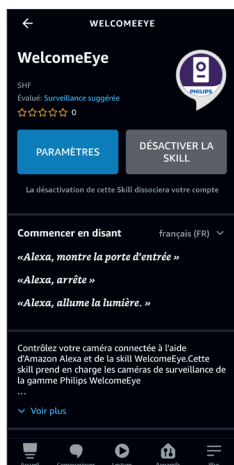

Google Assistant: Go to the GoogleHome application and add the "Philips WelcomeEye" application in the "Set up a device"/"Works with Google" section. Then enter the email address of your WelcomeEye account and its password.

Then, if necessary, run a new device detection on your voice assistant.

7. Usage

7.1. Viewing and managing video recordings

If you have configured video recordings following a motion detection or specific times have been set in the camera settings, the recordings can be viewed remotely from your application by clicking on  (History) from the application's main page:

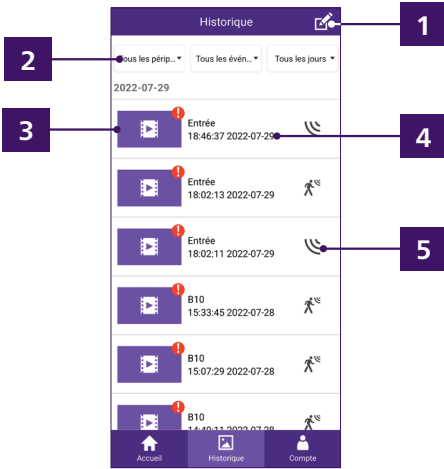

1	Edit: brings up the options for selecting and deleting videos if you wish
2	Filters if you are looking for a specific video
3	Recorded video: the  symbol indicates that you have not yet viewed the video
4	Name of the camera, date and time video was taken
5	Type of detection that triggered the recording

Click on a video to play it:

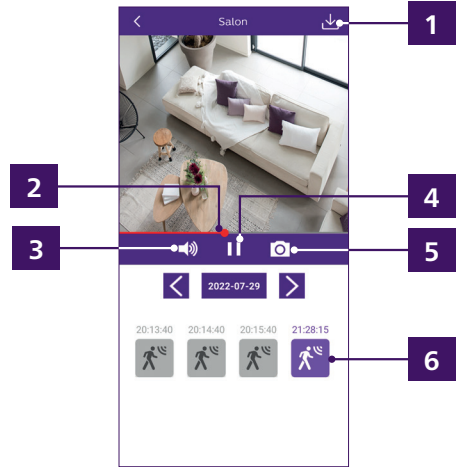

1	Download the video and save it to the smartphone's memory
2	Progress bar
3	Mute/unmute
4	Pause/resume playing
5	Screenshot the current video and save it to the smartphone's memory
6	Video being played with time of recording. You can select another video by clicking on it

7.2. Viewing the live feed

Click on your camera image from the application home screen:

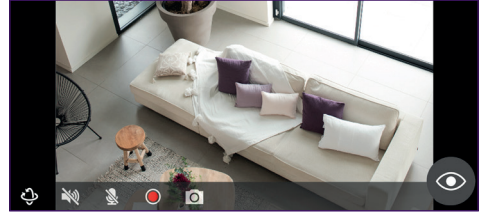
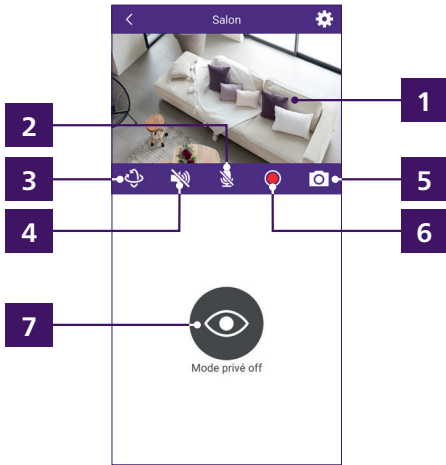

1	Pinch the screen with two fingers to zoom in on the image
2	Mute/unmute the smartphone's microphone: one click activates the microphone, so you can speak into the camera. A second click mutes the microphone
3	Motor control (shows left and right movement arrows in the image)
4	Mute/unmute the camera microphone
5	Take a photo and save it on your smartphone
6	Start recording live and save to smartphone memory
7	Activate the camera's private mode

Note: Activation of private mode also shuts off the siren function of your camera if it has been triggered.

These same controls are accessible if you switch your smartphone to landscape mode:

8. Technical features

Compatible with	Amazon Alexa - Google Home
Warranty	2 years
Power supply	230 V mains adapter (included)
Resolution	2k - 2560 x 1440 px
WiFi Network	2.4 GHz + 5 GHz 802.11 b/g/n/ac, Bluetooth, WiFi compatible with routers and modems from all European ISPs
Motor drive	Horizontal axis: 355° with auto-tracking function Vertical axis: 75°
Field of vision	360°
Audio	Two-way audio + siren with 90 dBA at 1 m
Infrared night vision	10m range
Operating temperature	-20°C ~ 55°C
Usage	Indoors, with option to set on a piece of furniture or to mount on the ceiling with the provided bracket.
Single product features	Dimensions: 135(h) x 80(l) x 80(d) mm Weight: 300 g
Standard and certification	CE, RoHS

9. FAQ - Common problems and solutions

Symptoms	Possible causes	Solutions
I can't install the WelcomeEye app on my Android device	You have an out-of-date or incompatible version of Android on your device	Please contact the technical support of your device's manufacturer in order to obtain a recent Android version.
	Google Play checks all the key components needed to run the application properly. If your equipment does not meet the necessary criteria, the installation will not be completed.	Try the installation on a different Android device.
I can't install the WelcomeEye app on my iPhone	The version of iOS on your device is out of date.	Update the operating system on your device.
The camera is not detected as being online when wanting to connect it to a smartphone	Time exceeded after switching on	Reset the camera and then restart Bluetooth detection
The camera is indicated as being associated with another account during start-up.	The camera must be available in order to be set up. If you wish to share it with another user, the process is different	Reset the camera using the button in the microSD card slot. If you would like to share the camera with the owner of another WelcomeEye account, use the "Partage" (Share) function in the camera settings.
Cannot connect to camera over local network	Network/power supply issue	Check your network and electrical connections.
	Network configuration problem	Check the network configuration and check that your camera is connected to the WiFi
The camera feed cannot be accessed over the internet	Network configuration problem	Check your device settings (box, router)
	Incorrect video settings	Check the video settings and reduce the quality if necessary
Poor quality or shaky image	Incorrect video settings	Check the video settings and reduce the quality if necessary
Movement detection is triggered unnecessarily	Unsuitable movement detection settings	Reduce the sensitivity of detection. Position the camera. Use figure detection rather than movement detection.

10. Technical support - Warranty

This product is guaranteed for parts and labour in our workshops.

The warranty does not cover: consumables (batteries, etc.) and damage caused by misuse, improper use, improper installation, external intervention, damage due to physical or electrical shocks, dropping or atmospheric phenomena.

- Never cover the device
- Clean with a soft cloth only, no solvents. The warranty is void if parts have been dismantled. Before cleaning, switch off the appliance and make sure that it does not trigger itself (deactivate the autotracking function if it is active).

 **Warning:** Do not use any carboxylic acid, alcohol, or similar chemicals on the product. In addition to damaging your device, the fumes are also hazardous to your health and are explosive. Do not use any tool that can conduct voltage (wire brush, sharp tool, etc.) for cleaning.

The receipt or invoice is proof of purchase date.

Contacts and opening hours of our technical support centres are available if necessary at www.philips.com

11. Safety measures

Damage caused by failing to adhere to the manual nullifies the warranty. We will not accept liability for damage resulting from non-compliance! We will not accept liability for any harm to goods or people caused by improper handling or failure to adhere to safety instructions.

This product was manufactured in total compliance with safety guidelines. In order to maintain this status and provide for the best possible conditions of usage, the user must adhere to the safety instructions and warnings in this manual.



This symbol indicates a risk of electrical shock or short-circuiting.

- Only use this product with electrical current in the following ranges: 100 - 240 Volts and 50 - 60 Hertz. Never attempt to use this device at a different voltage.
- Verify that all of the system's electrical connections are consistent with the usage instructions.
- In commercial establishments, be sure to adhere to accident prevention rules for electrical installations.
- For schools, training equipment, workshops, etc., the presence of qualified personnel is needed to monitor operation of the electronic devices.
- Adhere to the usage instructions for other devices connected to the system.
- Contact a person with experience if you are unsure about how to operate the system or about the safety of devices.
- Never plug in or unplug electrical devices with wet hands.
- When installing this product, verify that the power wires are not at risk of being damaged.
- An easily accessible cut-off system (switch disconnecter, circuit breaker, equivalent system) must be integrated into the building's wiring installation for the equipment connected to the power grid.
- Keep a minimum distance around the device to guarantee sufficient ventilation.
- Ventilation should not be blocked by covering the ventilation opening with an object such as a newspaper, tablecloth or curtain, etc.
- No open flame source such as a burning candle must be placed on the device.
- Respect the product's operating temperature.

- No objects filled with liquids, such as vases, should be placed on the appliance.

12. FCC/CE warning

Note: This equipment has been tested and found to be compliant with the limits of a Class B device, according to European standards in force. These limits are designed to provide reasonable protection against interference in a residential installation. This equipment uses and may emit radio frequency energy and, if not fitted and used according to the instructions, may cause interference to radio communication.

There is no guarantee, however, that interference will not occur in a particular system. If this equipment causes interference to radio or TV reception, which can be established by starting and stopping it, users are encouraged to try to correct the interference by one of the following methods:

- Redirect or move the receptor antenna
- Increase the distance between the equipment and the receptor
- Connect the equipment to a socket belonging to a different circuit from the one to which the receptor is connected

13. Declaration of Conformity

WITH the RED directive

AVIDSEN hereby declares that the equipment designated below:

WelcomeEye Look Camera DES8200HSC 531051

Complies with the RED 2014/53/EU directive and that its conformity has been assessed pursuant to the applicable standards in force:

- EN 62368-1: 2020+A11: 2020
- EN 62311: 2020
- EN 301 489-1 V2.2.3 (2019-11)
- EN 301 489-17 V3.2.4 (2020-09)
- EN 301 489-3 V2.1.1 (2019-03)
- EN 55032: 2015+A1: 2020
- EN 55035: 2017+A11: 2020
- EN 300 328 V2.2.2 (2019-07)
- EN 300 440 V2.2.1 (2018-07)
- EN 301893 V2.1.1 (2017-05)

Signed by Alexandre Chaverot, CEO, on behalf of Avidsen
19 avenue Marcel Dassault, 37200 Tours, France
IN Tours, 20/03/2023





FR - Ne jetez pas les piles et les appareils hors d'usage avec les ordures ménagères. Les substances dangereuses qu'ils sont susceptibles de contenir peuvent nuire à la santé et à l'environnement. Faites reprendre ces appareils par votre distributeur ou utilisez les moyens de collecte sélective mise à votre disposition par votre commune. Directive WEEE 2012/19/EU

EN - Do not throw away batteries or out-of-order products with household waste (rubbish). The dangerous substances that they may contain may be harmful to health and the environment. Return these products to the distributor or use the recycling and waste disposal services offered by your municipality. Directive WEEE 2012/19/EU

NL - De lege batterijen en oude apparaten niet met het huisvuil meegeven: deze kunnen gevaarlijke stoffen bevatten die de gezondheid en het milieu schaden. De oude apparaten door uw distributeur laten innemen of de gescheiden vuilinzameling van uw gemeente gebruiken. Directive WEEE

2012/19/EU
DE - Verbrauchte Batterien und nicht mehr benützte Geräte sind Sondermüll. Sie enthalten möglicherweise gesundheits- und umweltschädliche Substanzen. Geben Sie alte Geräte zur fachgerechten Entsorgung beim Gerätehändler ab bzw. benutzen Sie die örtlichen Recyclinghöfe. Directive WEEE 2012/19/EU

ES - No tire las pilas ni los aparatos inservibles con los residuos domésticos, ya que las sustancias peligrosas que puedan contener pueden perjudicar la salud y al medio ambiente. Pídale a su distribuidor que los recupere o utilice los medios de recogida selectiva puestos a su disposición por el ayuntamiento. Directive WEEE 2012/19/EU

PT - Não junte as pilhas nem os aparelhos que já não se usam com o lixo caseiro. As substâncias perigosas que ambos podem conter podem ser prejudiciais para a saúde e para o ambiente. Entregue esses aparelhos ao seu lixeiro ou recorra aos meios de recolha selectiva a seu dispor. Directive WEEE 2012/19/EU

IT - Non gettare le pile e le apparecchiature fuori uso insieme ai rifiuti domestici. Le sostanze dannose contenute in esse possono nuocere alla salute dell'ambiente. Restituire questo materiale al distributore o utilizzare la raccolta differenziata organizzata dal comune. Directive WEEE 2012/19/EU

PL - Nie wyrzucać zużytych baterii i zepsutych urządzeń do śmieci. Substancje niebezpieczne, które mogą zawierać są szkodliwe dla zdrowia i środowiska. Urządzenia należy zwrócić do dystrybutora lub wykorzystać system zbiórki selektywnej dostępny na terenie gminy. Dyrektywa WEEE 2012/19/EU



Pour en savoir plus : www.quefairedemesdechets.fr



FR - Ce symbole indique que l'appareil s'installe et s'utilise uniquement à l'intérieur
EN - This symbol indicates that the device must only be installed and used indoors
NL - Dit symbool betekent dat het apparaat alleen binnen mag worden geïnstalleerd en gebruikt
DE - Dieses Symbol zeigt an, dass das Gerät nur innen installiert und verwendet wird
ES - Este símbolo indica que el aparato se instala y utiliza únicamente en el interior
PT - Este símbolo indica que o aparelho só pode ser instalado e usado em interiores
IT - Questo simbolo indica che l'apparecchio si installa e si utilizza unicamente all'interno
PL - Ten symbol wskazuje, iż urządzenie przeznaczone jest wyłącznie do montażu i użytku wewnętrznego



FR - La protection des appareils qui portent ce symbole est assurée par une double isolation et ne requiert pas de branchement de sécurité à la terre/masse électrique.
EN - The protection of devices bearing this symbol is guaranteed by double insulation, they do not require a safety connection to electrical earth.
NL - Apparatuur die voorzien is van dit symbool, wordt beschermd door een dubbele isolatie en vereist geen beveiligde elektriciteitsaansluiting op de aarde/massa.
DE - Der Schutz der dieses Symbol tragenden Geräte wird durch eine zweifache Isolation gewährleistet und erfordert keinen elektrischen Schutzanschluss an Erde/Masse.
ES - La protección de los aparatos que llevan este símbolo está garantizada por un doble aislamiento y no requiere una conexión de seguridad a tierra/masa eléctrica.
PT - A proteção dos aparelhos que contêm este símbolo é assegurada através de isolamento dupla e não necessita de ligações de segurança à terra/massa elétrica.
IT - La protezione delle apparecchiature che riportano questo simbolo è garantita da un doppio isolamento e non necessita di messa a terra/collegamento a massa.
PL - Urządzenia oznaczone takim symbolem są chronione podwójną izolacją i nie wymagają one bezpiecznego podłączenia do ziemiennia/masy.



FR - Courant continu
EN - Direct Current
NL - Draaistroom
DE - Gleichstrom
ES - Corriente continua
PT - Corrente contínua
IT - Corrente continua
PL - Prąd stały



FR - Courant alternatif
EN - Alternating Current
NL - Gelijkstroom
DE - Wechselstrom
ES - Corriente alterna
PT - Corrente alterna
IT - Corrente alternata
PL - Prąd zmienny



For support visit: www.philips.com/support

2023©Avidsen. All rights reserved. Philips and the Philips Shield Emblem are registered trademarks of Koninklijke Philips N.V. and are used under license. This product has been manufactured and is sold under the responsibility of AVIDSEN SAS, and AVIDSEN SAS is the warrantor in relation to this product.