

[Home](#)

[안전 및 문제 해결](#)

[본 매뉴얼에 관하여](#)

[제품 정보](#)

[모니터 설치](#)

[화면 디스플레이](#)

[고객 관리 및 보증](#)

[어휘](#)

[다운로드 및 인쇄](#)

LCD Monitor **190EW8**



Safety and Troubleshooting Information

- : 0 ~ 40°C(32 ~104°F)
- : 20~80% RH

:

가 " / . (" " .)



가

가

FAQ ()

FAQ

Q: "Cannot display this video mode" 가 ?

A: 19" : 1440 x 900@60Hz.

1. , PC () .
2. / " " " "
3. " 1440 x 900 (19")
4. " 60Hz , PC가 1440 x 900@60Hz
5. 2 3 LCD
6. PC .

Q: LCD " " ?

A: LCD . LCD 60Hz . 60Hz 85Hz .

Q: CD-ROM .inf .icm ? (.inf .icm) ?

A: 가 (.inf .icm) . (.inf .icm)가 .

Q: ?

A: / 가 가 . Windows® "Display properties" () .

Q: ?

A: 'MENU' 'Reset' () .

Q: Auto ?

A: AUTO , OSD(On Screen Display) 가 .

:

Q: (LED) . ?

A: AC 가 AC , PC

Q: PC LCD ?

A: .
.

Q: LCD 가 ?

A: (TFT) 가 CRT LCD ,

Q: LCD 가 ?

A: LCD (가 2H) . , .

Q: LCD ?

A: . , , . .

Q: ?

A: , OSD .

- 1. "MENU" OSD(On Screen Display)
- 2. " " "color()" "MENU" .
가 가 .

- a. 6500K; - 가 .
- b. 9300K; - 가 .
- c. Original(); . (:
가 .*)
- d. User Define(); 가 , ,
- e. sRGB; (: , , ,)

* 가 ,9300K 가 . 6504K () . 2004K 가

Q: Philips LCD ?

A: , Brilliance LCD Philips VESA Philips Philips 4 VESA 가

Q: CD-ROM FPadjust ?

A: FPadjust , , , , 가

Q: ?

A:

1. MENU' 1440 x 900@60Hz for 19" . OSD : 'OSD . OSD 가
2. CD-ROM (FPadjust) , CD-ROM FPadjust FP_setup4.3.exe 가 FPadjust
3. FPadjust

Q: LCD CRT 가 ?

A: LCD CRT , CRT 가 .
가

Q: Philips LCD ?

A: , Windows® 95, 98, 2000, XP Vista 가 .
가

LCD

Q: LCD(Liquid Crystal Display)가 ?

A: LCD , LCD ASCII , ,
LCD , LCD (CRT) LCD LED 가 -
LCD 가

Q: LCD LCD ?

A: LCD 가
LCD 가 (, 가).

Q: CRT TFT LCD ?

A: CRT 가 , CRT
RGB . TFT LCD
. TFT CRT :
가 . TFT LCD , 가
. TFT LCD CRT 가 . TFT LCD

Q: LCD 60Hz가 ?

A: CRT , TFT LCD 가 , 1024x3(R,G,B)x768
XGA 가 . XGA
65Mhz /
60Hz/48kHz , 60Hz가 .

Q: (wide-angle) ? ?

A: TFT LCD , TFT LCD
TFT LCD CDT
, 가 (viewing angle) , 가
10 (wide viewing angle)
Vertical Aligned) 가 . IPS(In Plane Switching) MVA(Multi

Q: LCD ?

A: , LCD . LCD CRT
, LCD , CRT
. LCD 가 , LCD

Q: LCD

가 ?

A: CRT

, LCD

,

.

, LCD

가

Q: LCD

?

A: .

MPR-II

LCD

TCO 99/03

가

,

,

,

,

가

-
- FAQs
-
-
-
-

가 . 가 , Philips

가	
(LED가)	ON 가 OFF
(LED가)	가 가
ATTENTION CHECK CABLE CONNECTION	가

AUTO	Auto IBM- PC 가 PC
가	Auto OSD) 가 Phase/Clock(/
	PC
	Auto OSD Phase/Clock(/) 가

	<p>Auto OSD Phase/Clock(/) 가</p>
	<p>OSD(On - Screen Display) . (LCD .)</p>
<p>, , , , 가</p>	
<p>가</p>	<p>Philips 가</p>

- [Recycling Information for Customers Waste Electrical and](#)
- [Electronic Equipment-WEEE](#)
- [Energy Star Declaration](#)
- [BSMI Notice \(Taiwan Only\)](#)
- [China RoHS in EDFU](#)
- [Troubleshooting](#)
- [Other Related Information](#)
- [Frequently Asked Questions \(FAQs\)](#)

Regulatory Information

Product Name:	190EW8
Model ID:	190EW8CB/93
Model No:	HWC7190A

Recycling Information for Customers

Philips establishes technically and economically viable objectives to optimize the environmental performance of the organization's product, service and activities.

From the planning, design and production stages, Philips emphasizes the important of making products that can easily be recycled. At Philips, end-of-life management primarily entails participation in national take-back initiatives and recycling programs whenever possible, preferably in cooperation with competitors.

There is currently a system of recycling up and running in the European countries, such as The Netherlands, Belgium, Norway, Sweden and Denmark.

In U.S.A., Philips Consumer Electronics North America has contributed funds for the Electronic Industries Alliance (EIA) Electronics Recycling Project and state recycling initiatives for end-of-life electronics products from household sources. In addition, the Northeast Recycling Council (NERC) - a multi-state non-profit organization focused on promoting recycling market development - plans to implement a recycling program.

In Asia Pacific, Taiwan, the products can be taken back by Environment Protection Administration (EPA) to follow the IT product recycling management process, detail can be found in web site www.epa.gov.tw

The monitor contains parts that could cause damage to the nature environment. Therefore, it is vital that the monitor is recycled at the end of its life cycle. For help and service, please contact [Consumers Information Center](#) or [F1rst Choice Contact Information Center](#) in each country or the following team of Environmental specialist can help.

Mr. WY Chen- Environment manager
Philips Multimedia Flat Display
E-mail: w.y.chen@philips.com

Tel: +886 (0) 3 222 6791

Mr. Maarten ten Houten - Senior Environmental Consultant
Philips Consumer Electronics
E-mail: marten.ten.houten@philips.com
Tel: +31 (0) 40 27 33402

Mr. Delmer F. Teglas
Philips Consumer Electronics North America
E-mail: butch.teglas@philips.com
Tel: +1 865 521 4322

[RETURN TO TOP OF THE PAGE](#)

Waste Electrical and Electronic Equipment-WEEE

Attention users in European Union private households



This marking on the product or on its packaging illustrates that, under European Directive 2002/96/EG governing used electrical and electronic appliances, this product may not be disposed of with normal household waste. You are responsible for disposal of this equipment through a designated waste electrical and electronic equipment collection. To determine the locations for dropping off such waste electrical and electronic, contact your local government office, the waste disposal organization that serves your household or the store at which you purchased the product.

[RETURN TO TOP OF THE PAGE](#)

Energy Star Declaration

This monitor is equipped with a function for saving energy which supports the VESA Display Power Management Signaling (DPMS) standard. This means that the monitor must be connected to a computer which supports VESA DPMS. Time settings are adjusted from the system unit by software.

	VESA State	LED Indicator	Power Consumption
Normal operation	ON (Active)	Green	< 36 W (typ.)
Power Saving Alternative 2 One step	OFF (Sleep)	Amber	< 1 W
	Switch Off	Off	< 1 W



As an ENERGY STAR® Partner, PHILIPS has determined that this product meets the ENERGY STAR® guidelines for energy efficiency.



We recommend you switch off the monitor when it is not in use for a long time.

[RETURN TO TOP OF THE PAGE](#)

BSMI Notice (Taiwan Only)

符合乙類資訊產品之標準

[RETURN TO TOP OF THE PAGE](#)

China RoHS in EDFU

The People's Republic of China released a regulation called "Management Methods of Controlling Pollution by Electronic Information Products" or commonly referred to as China RoHS. All products including CRT and LCD monitor which produced and sold for China market have to meet China RoHS request.

中国大陆RoHS

根据中国大陆《电子信息产品污染控制管理办法》（也称为中国大陆RoHS），以下部分列出了本产品中可能包含的有毒有害物质或元素的名称和含量。

本表选用之产品

显示器（液晶及CRT）

有毒有害物质或元素

部件名称	有毒有害物质或元素					
	铅 (Pb)	汞 (Hg)	镉 (Cd)	六价铬 (Cr (VI))	多溴联苯 (PBB)	多溴二苯醚 (PBDE)
外壳	O	O	O	O	O	O
CRT显示屏	X	O	O	O	O	O
液晶显示屏/灯管	X	X	O	O	O	O

电路板组件*	X	O	O	O	O	O
電源選配器	X	O	O	O	O	O
電源線/連接線	X	O	O	O	O	O
<p>*：电路板组件包括印刷电路板及其构成的零部件，如电阻、电容、集成电路、连接器等。</p> <p>：表示该有毒有害物质在该部件所有均质材料中的含量均在《电子信息产品中有毒有害物质的限量要求标准》规定的限量要求以下。</p> <p>x：表示该有毒有害物质至少在该部件的某一均质材料中的含量超出《电子信息产品中有毒有害物质的限量要求标准》规定的限量要求；但是上表中打“x”的部件，符合欧盟RoHS法规要求 属于豁免的部分。</p>						

[RETURN TO TOP OF THE PAGE](#)

- [FAQs](#)

115 V :
18 AWG, Type SVT SJT three , 15 , 15A, 125V 가
UL

230 V :
18 AWG, Type SVT SJT three , 15 , 15A, 250V 가
UL

230 V :
18 AWG 가 15A, 250V HAR 가 가 . 가

가

Consumer Information Centers

Antilles • Argentina • Australia • Bangladesh • Brasil • Canada • Chile • China • Colombia • Belarus • Bulgaria • Croatia • Czech Republic • Estonia • Dubai • Hong Kong • Hungary • India • Indonesia • Korea • Latvia • Lithuania • Malaysia • Mexico • Morocco • New Zealand • Pakistan • Paraguay • Peru • Philippines • Poland • Romania • Russia • Serbia & Montenegro • Singapore • Slovakia • Slovenia • South Africa • Taiwan • Thailand • Turkey • Ukraine • Uruguay • Venezuela

Eastern Europe

BELARUS

Technical Center of JV IBA
M. Bogdanovich str. 155
BY - 220040 Minsk
Tel: +375 17 217 33 86

BULGARIA

LAN Service
140, Mimi Balkanska Str.
Office center Translog
1540 Sofia, Bulgaria
Tel: +359 2 960 2360
www.lan-service.bg

CZECH REPUBLIC

Xpectrum
Lužná 591/4
CZ - 160 00 Praha 6 Tel: 800 100 697
Email: info@xpectrum.cz
www.xpectrum.cz

CROATIA

Renoprom d.o.o.
Mlinska 5, Strmec
HR - 41430 Samobor
Tel: +385 1 333 0974

ESTONIA

FUJITSU SERVICES OU
Akadeemia tee 21G
EE-12618 Tallinn
Tel: +372 6519900
www.ee.invia.fujitsu.com

HUNGARY

Serware Szerviz
Vizimolnár u. 2-4
HU - 1031 Budapest
Tel: +36 1 2426331
Email: inbox@serware.hu
www.serware.hu

LATVIA

ServiceNet LV
Jelgavas iela 36
LV - 1055 Riga,
Tel: +371 7460399
Email: serviss@servicenet.lv

LITHUANIA

ServiceNet LT
Gaiziunu G. 3
LT - 3009 KAUNAS
Tel: +370 7400088
Email: servisas@servicenet.lt
www.servicenet.lt

ROMANIA

Blue Ridge Int'l Computers SRL
115, Mihai Eminescu St., Sector 2
RO - 020074 Bucharest
Tel: +40 21 2101969

SERBIA & MONTENEGRO

Tehnicom Service d.o.o.
Bulevar Vojvode Misica 37B
YU - 11000 Belgrade
Tel: +381 11 3060 886

SLOVAKIA

Datalan Servisne Stredisko
Puchovska 8
SK - 831 06 Bratislava
Tel: +421 2 49207155
Email: servis@datalan.sk

SLOVENIA

PC HAND
Brezovce 10
SI - 1236 Trzin
Tel: +386 1 530 08 24
Email: servis@pchand.si

POLAND

Zolter
ul.Zytia 1
PL - 05-500 Piaseczno
Tel: +48 22 7501766
Email: servmonitor@zolter.com.pl
www.zolter.com.pl

RUSSIA

Tel: +7 095 961-1111

Tel: 8-800-200-0880

Website: www.philips.ru

TURKEY

Türk Philips Ticaret A.S.

Yukari Dudullu Org.San.Bolgesi

2.Cadde No:22

34776-Umraniye/Istanbul

Tel: (0800)-261 33 02

UKRAINE

Comel

Shevchenko street 32

UA - 49030 Dnepropetrovsk

Tel: +380 562320045

www.csp-comel.com

Latin America

ANTILLES

Philips Antillana N.V.

Kaminda A.J.E. Kusters 4

Zeelandia, P.O. box 3523-3051

Willemstad, Curacao

Phone: (09)-4612799

Fax : (09)-4612772

ARGENTINA

Philips Antillana N.V.
Vedia 3892 Capital Federal
CP: 1430 Buenos Aires
Phone/Fax: (011)-4544 2047

BRASIL

Philips da Amazônia Ind. Elet. Ltda.
Rua Verbo Divino, 1400-São Paulo-SP
CEP-04719-002
Phones: 11 21210203 -São Paulo & 0800-701-0203-Other Regions without São Paulo City

CHILE

Philips Chilena S.A.
Avenida Santa Maria 0760
P.O. box 2687 Santiago de Chile
Phone: (02)-730 2000
Fax : (02)-777 6730

COLOMBIA

Industrias Philips de Colombia
S.A.-Division de Servicio
CARRERA 15 Nr. 104-33
Bogota, Colombia
Phone:(01)-8000 111001 (toll free)
Fax : (01)-619-4300/619-4104

MEXICO

Consumer Information Centre
Norte 45 No.669
Col. Industrial Vallejo
C.P.02300, -Mexico, D.F.
Phone: (05)-3687788 / 9180050462
Fax : (05)-7284272

PARAGUAY

Av. Rca. Argentina 1780 c/Alfredo Seiferheld
P.O. Box 605
Phone: (595 21) 664 333
Fax: (595 21) 664 336
Customer Desk:
Phone: 009 800 54 1 0004

PERU

Philips Peruana S.A.
Customer Desk
Comandante Espinar 719
Casilla 1841
Limab18
Phone: (01)-2136200
Fax : (01)-2136276

URUGUAY

Rambla O'Higgins 5303 Montevideo
Uruguay
Phone: (598) 619 66 66
Fax: (598) 619 77 77
Customer Desk:
Phone: 0004054176

VENEZUELA

Industrias Venezolanas Philips S.A.
Apartado Postal 1167
Caracas 1010-A
Phone: (02) 2377575
Fax : (02) 2376420

Canada

CANADA

Philips Electronics Ltd.
281 Hillmount Road
Markham, Ontario L6C 2S3
Phone: (800) 479-6696

Pacific

AUSTRALIA

Philips Consumer Electronics
Consumer Care Center
Level 1, 65 Epping Rd
North Ryde NSW 2113
Phone: 1300 363 391
Fax : +61 2 9947 0063

NEW ZEALAND

Philips New Zealand Ltd.
Consumer Help Desk
2 Wagener Place, Mt.Albert
P.O. box 1041
Auckland
Phone: 0800 477 999 (toll free)
Fax : 0800 288 588

Asia

BANGLADESH

Philips Service Centre
100 Kazi Nazrul Islam
Avenue Kawran Bazar C/A
Dhaka-1215
Phone: (02)-812909
Fax : (02)-813062

CHINA

SHANGHAI

Rm 1007, Hongyun Building, No. 501 Wuning road,
200063 Shanghai P.R. China
Phone: 4008 800 008
Fax: 21-52710058

HONG KONG

Philips Electronics Hong Kong Limited
Consumer Service
Unit A, 10/F. Park Sun Building
103-107 Wo Yi Hop Road
Kwai Chung, N.T.
Hong Kong
Phone: (852)26199663
Fax: (852)24815847

INDIA

Phone: 91-20-712 2048 ext: 2765
Fax: 91-20-712 1558

BOMBAY

Philips India
Customer Relation Centre
Bandbox House
254-D Dr. A Besant Road, Worli
Bombay 400 025

CALCUTTA

Customer Relation Centre
7 justice Chandra Madhab Road
Calcutta 700 020

MADRAS

Customer Relation Centre
3, Haddows Road
Madras 600 006

NEW DELHI
Customer Relation Centre
68, Shivaji Marg
New Dehli 110 015

INDONESIA

Philips Group of Companies in Indonesia
Consumer Information Centre
Jl.Buncit Raya Kav. 99-100
12510 Jakarta
Phone: (021)-7940040 ext: 2100
Fax : (021)-794 7511 / 794 7539

KOREA

Philips Consumer Service
Jeong An Bldg. 112-2
Banpo-dong, Seocho-Ku
Seoul, Korea
Customer Careline: 080-600-6600
Phone: (02) 709-1200
Fax : (02) 595-9688

MALAYSIA

After Market Solutions Sdn Bhd,
Philips Authorised Service Center,
Lot 6, Jalan 225, Section 51A,
46100 Petaling Jaya,
Selangor Darul Ehsan,
Malaysia.
Phone: (603)-7954 9691/7956 3695
Fax: (603)-7954 8504
Customer Careline: 1800-880-180

PAKISTAN

Philips Consumer Service
Mubarak manzil,
39, Garden Road, Saddar,
Karachi-74400
Tel: (9221) 2737411-16
Fax: (9221) 2721167
E-mail: care@philips.com
Website: www.philips.com.pk

PHILIPPINES

PHILIPS ELECTRONICS & LIGHTING, INC.
Consumer Electronics
48F PBCOM tower
6795 Ayala Avenue cor VA Rufino St.
Salcedo Village
1227 Makati City, PHILS
Phone: (02)-888 0572, Domestic Toll Free: 1-800-10-PHILIPS or 1-800-10-744 5477
Fax: (02)-888 0571

SINGAPORE

Accord Customer Care Solutions Ltd
Authorized Philips Service Center
Consumer Service
620A Lorong 1 Toa Rayoh
Singapore 319762
Tel: +65 6882 3999
Fax: +65 6250 8037

TAIWAN

Philips Taiwan Ltd.
Consumer Information Centre
13F, No. 3-1 Yuan Qu St., Nan Gang Dist.,
Taipei 115, Taiwan
Phone: 0800-231-099
Fax : (02)-3789-2641

THAILAND

Philips Electronics (Thailand) Ltd.
26-28th floor, Thai Summit Tower
1768 New Petchburi Road
Khwaeng Bangkapi, Khet Huaykhwang
Bangkok10320 Thailand
Tel: (66)2-6528652
E-mail: cic Thai@philips.com

Africa

MOROCCO

Philips Electronique Maroc
304,BD Mohamed V
Casablanca
Phone: (02)-302992
Fax : (02)-303446

SOUTH AFRICA

PHILIPS SA (PTY) LTD
Customer Care Center
195 Main Road
Martindale, Johannesburg
P.O. box 58088
Newville 2114
Telephone: +27 (0) 11 471 5194
Fax: +27 (0) 11 471 5123
E-mail: customercare.za@philips.com

Middle East

DUBAI

Philips Middle East B.V.
Consumer Information Centre
P.O.Box 7785
DUBAI
Phone: (04)-335 3666
Fax : (04)-335 3999

F1rst Choice

가				
Austria	+43	0820 901115		€ 0.20
Belgium	+32	070 253 010		€ 0.17
Denmark	+45	3525 8761		
Finland	+358	09 2290 1908		
France	+33	08 9165 0006		€ 0.23
Germany	+49	0180 5 007 532		€ 0.12
Greece	+30	00800 3122 1223		
Ireland	+353	01 601 1161		
Italy	+39	199 404 042		€ 0.25
Luxembourg	+352	26 84 30 00		
The Netherlands	+31	0900 0400 063		€ 0.20
Norway	+47	2270 8250		
Portugal	+351	2 1359 1440		
Spain	+34	902 888 785		€ 0.15
Sweden	+46	08 632 0016		
Switzerland	+41	02 2310 2116		
United Kingdom	+44	0207 949 0069		

-
-

LCD

. LCD

, ,

.

:

,

가

,

.

가

,

가

가

.

,

.

:



가

가

2006 Koninklijke Philips Electronics N.V.

. Philips Electronics N.V. 가

LCD	
•	TFT LCD
•	19"
•	0.284 x 0.284 mm
• LCD	1440 x 900 R.G.B.
•	408.2 x 255.2 mm
•	16.7M
•	
•	56 Hz - 76 Hz
•	30 kHz - 83 kHz
•	
•	140 MHz
•	
-	75 Ohm
-	2.2K Ohm
•	700m Vpp
•	

•	
•	6
•	x: 0.283 y: 0.299 (9300° K) x: 0.313 y: 0.329 (6500° K)

*

가

&

A:

- 190EW8

75 Hz 1440 x 900 ()

B:

- 190EW8

60 Hz 1440 x 900 ()

15

:

H. freq (kHz)		H. freq (Hz)
31.469	720*400	70.087
31.469	640*480	59.940
37.500	640*480	75.000
35.156	800*600	56.250
37.879	800*600	60.317
46.875	800*600	75.000
48.363	1024*768	60.004
60.023	1024*768	75.029
55.935	1440*900	59.887
70.635	1440*900	74.984
35.000	640*480	67.000
31.469	640*350	70.086
63.981	1280*1024	60.020
79.976	1280*1024	75.025
55.469	1440*900	59.901

가

VESA DPMS

가 PC

가

"

,

".

:



VESA		H-sync	V-sync		LED
				< 37 W (typ.)	
				< 1 W	
		-	-	< 1 W	

가 ENERGY STAR® . ENERGY STAR® , PHILIPS ENERGY STAR®

가

• (WxHxD) *	450,3 x 387,5 x 167,7 mm ()
•	4.64 Kg
•	-5° ~ 20°
•	100 ~ 240 VAC, 50/60 Hz
•	37W* (typ.)
•	0 ° C ~ 40° C -20°C ~ 60° C
•	20% 80%
• MTBF	50K (CCFL 40K)

	190EW8CB:
--	-----------

*

* 1440 x 900, , 50%, , 6500°K, .

가

15- D-sub (male):

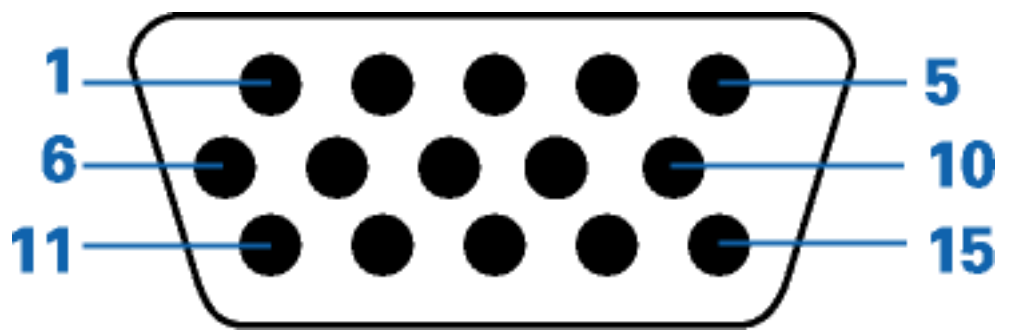

1		9	+3.3V
2	/SOG	10	

3		11	
4	Sense ()	12	(SDA)
5	-	13	H. Sync / H+V
6		14	V. Sync
7		15	(SCL)
8			

가

가

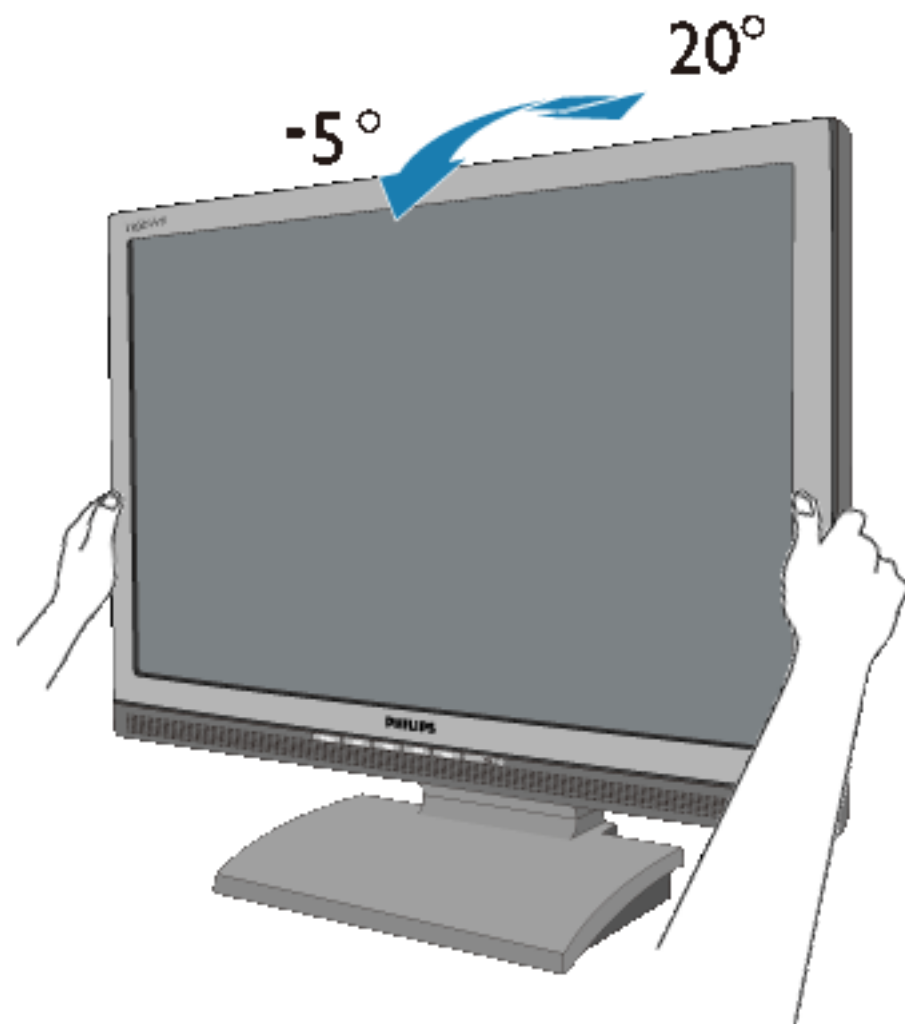

가

-
-
- &
-
-
-
-
-

TFT LCD

0.0004% , TFT LCD 가 , 15" XGA

() , 가

가 가

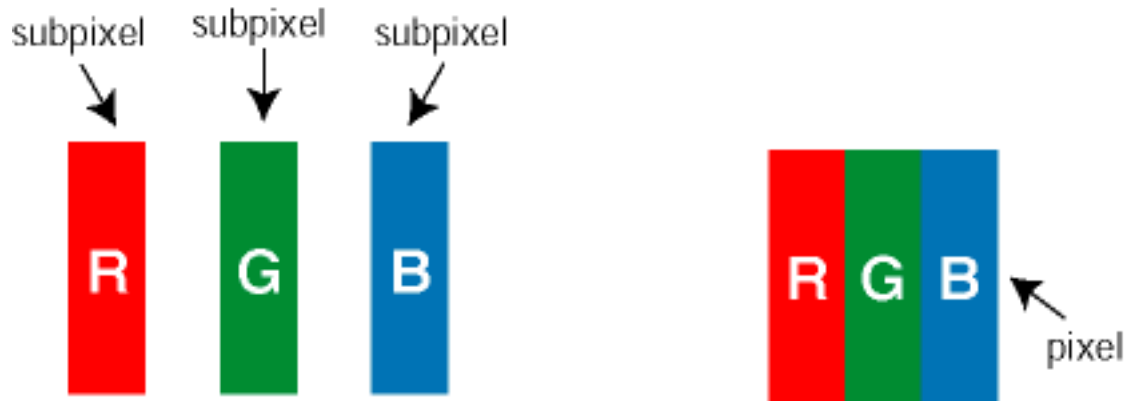

가
가

가

가

(bright dot)

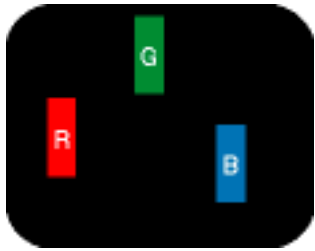

- + =
- + =
- + =

() 가



30%

50%

(black dot)

" "

가

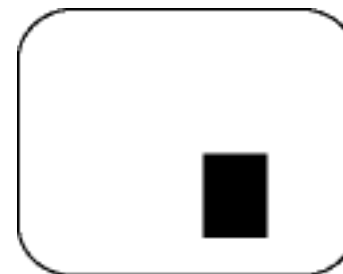
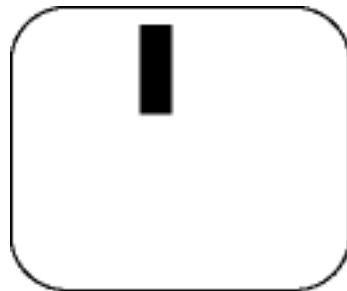

TFT LCD

	190EW8
	3
	1
()	0
*	>25mm
	3

	190EW8
	5

	2
	1
*	> 15mm
	5

	190EW8
	5

:

* = 1

Philips ISO13406-2 .

가

LCD

- PC

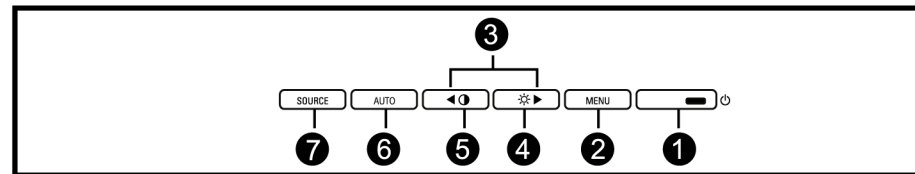
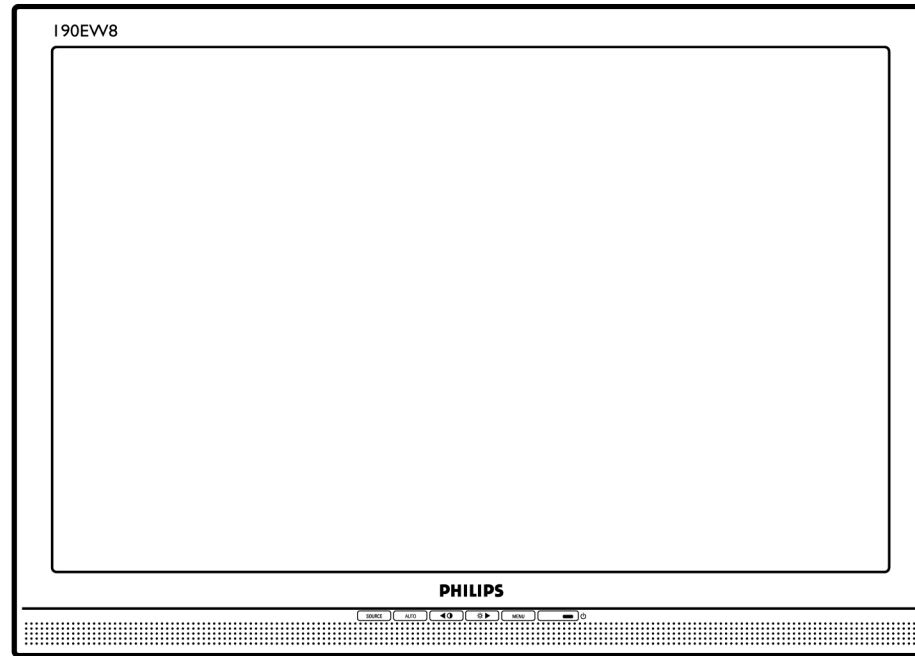



1



- 2 **MENU** OSD /

- 3 <>

- 4 

- 5 

- 6 AUTO , ,

- 7 **SOURCE**

가

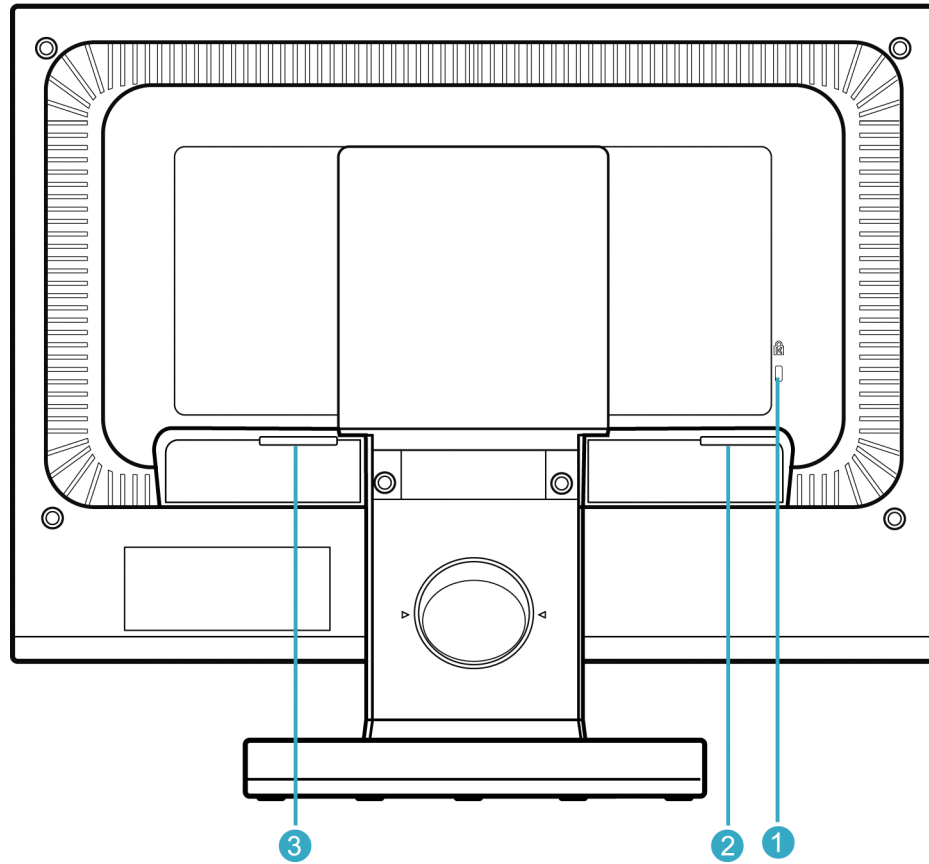

- 1
- 2 VGA
- 3 AC

가

1440 x 900@60Hz



OSD

'MENU'

(FP Adjust)

CD



FP_Setup4.3.exe

가

-
-
- PC
-
-
-

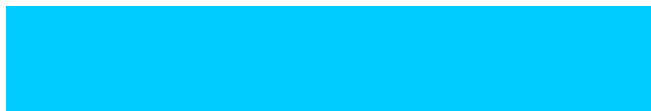



E-DFU

가

PC

1)

. (VGA .)

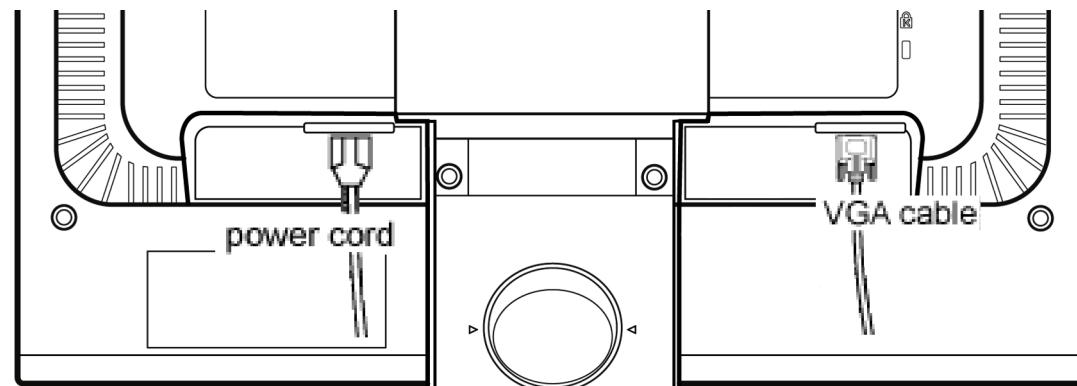

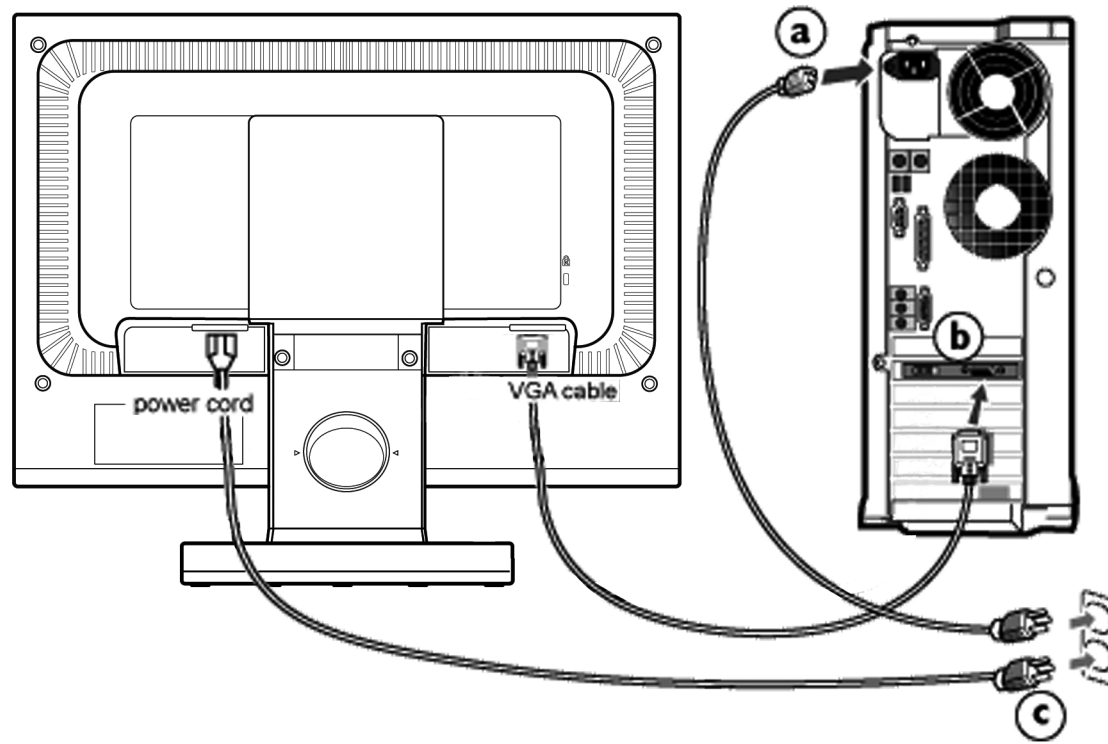

2) PC

(a)

(b)

(c)

(d)

가

가

가

가

LCD :

-
-
-
-

(.inf) Windows® 95/98/2000/Me/XP/Vista

VESA DDC2B Windows® 95/98/2000/Me/Vista
 Windows® 95/98/2000/Me/XP/Vista “ ” 가
 (.inf) .Windows® '95 OEM Release 2 , 98 , 2000, Me, XP Vista

Windows® 95

1. Windows® 95
2. ' ' 가 ' ' .
3. ' ' .
4. ' ' ' ... ' .
5. ' ' ' ... ' 가 ' ' ... ' .
6. ' ... ' F: (CD-ROM ') .
7. ' ' .
8. ' ' .

Windows® 98

1. Windows® 98
2. ' ' 가 ' ' .
3. ' ' .
4. ' ' ' ... ' .
5. ' ' ' ... ' .
6. ' ' ' ' ' ' ... ' .
7. ' ... ' F: (CD-ROM ') .
8. ' ' .
9. ' ' .

Windows® 2000

1. Windows® 2000
2. ... 가 ...
3. ...
4. ...
5. ... 가 ...
6. ...
7. ...
8. ... F: (CD-ROM)
9. ...
10. ...
11. ... 가 ...

Windows® Me

1. Windows® Me
2. ... 가 ...
3. ...
4. ...
5. ...
6. ... ()'
7. ...
8. ... F: (CD-ROM)
9. ...
10. ...

Windows® XP

1. Windows® XP
2. " " " "
3. " "
4. " " " "
5. " " 가 ...

-
-
- PC
-
-
-

:

VESA

1. 2 LCD .
2. .

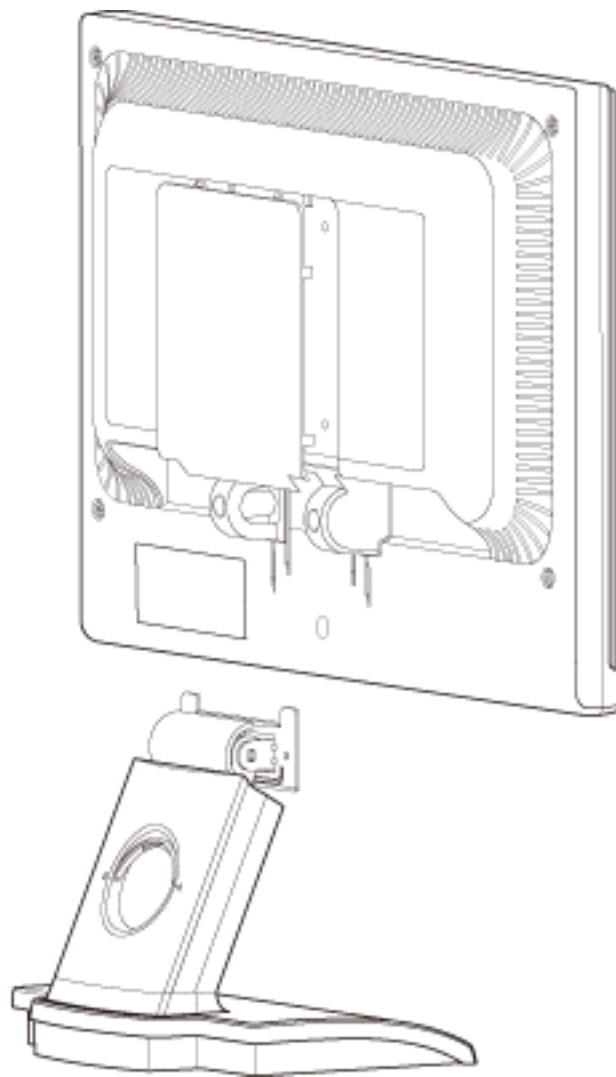

100mmx100mm VESA-

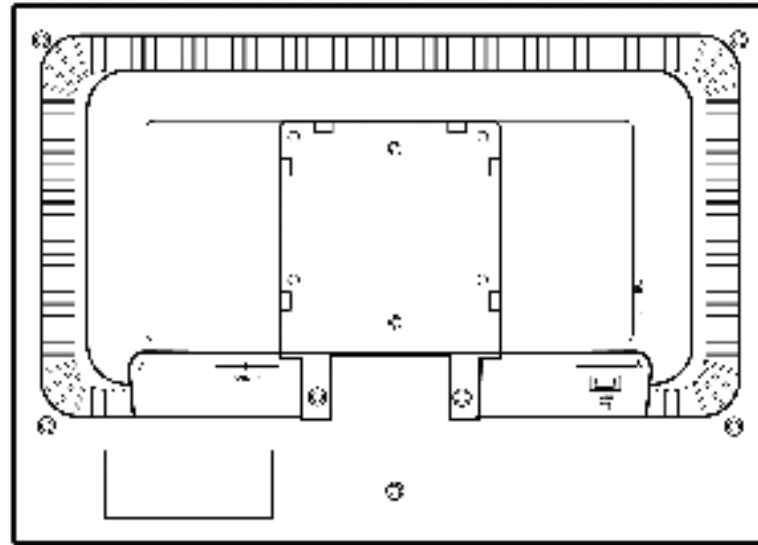

가

• LCD

•

• FPadjust

LCD

95, 98, 2000, Me, XP, Vista PC
".inf/.icm/.cat" : /PC/drivers/

"Readme.txt"

Acrobat Reader .pdf

. PDF

Adobe® Acrobat Reader 가
Reader for PC / Adobe® Acrobat Reader.

. PC Adobe® Acrobat

:

:

1.

. (Win95/98/2000/Me/XP/Vista)

FPadjust

:

FPadjust

. (Win95/98/2000/Me/XP/Vista)



FP_setup4.3.exe

가 FPadjust
).
가 FPadjust

"FP_Readme4.3.txt"

가

-
- OSD

가?

LCD 가 , 가

MENU (OSD) 가



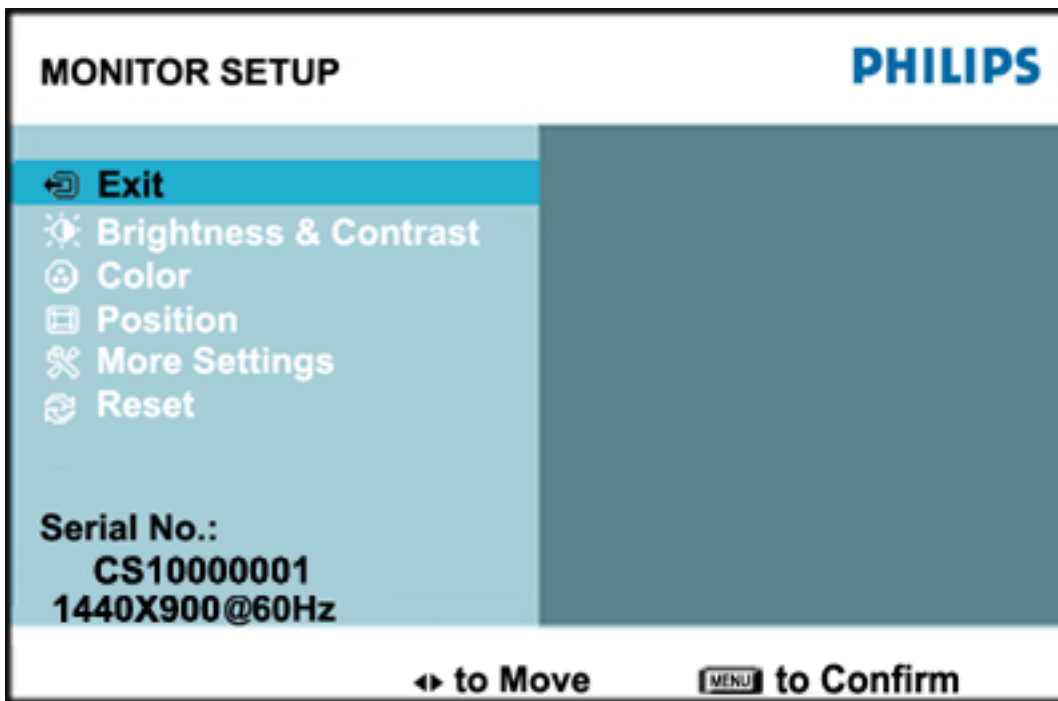

가

OSD

(OSD)



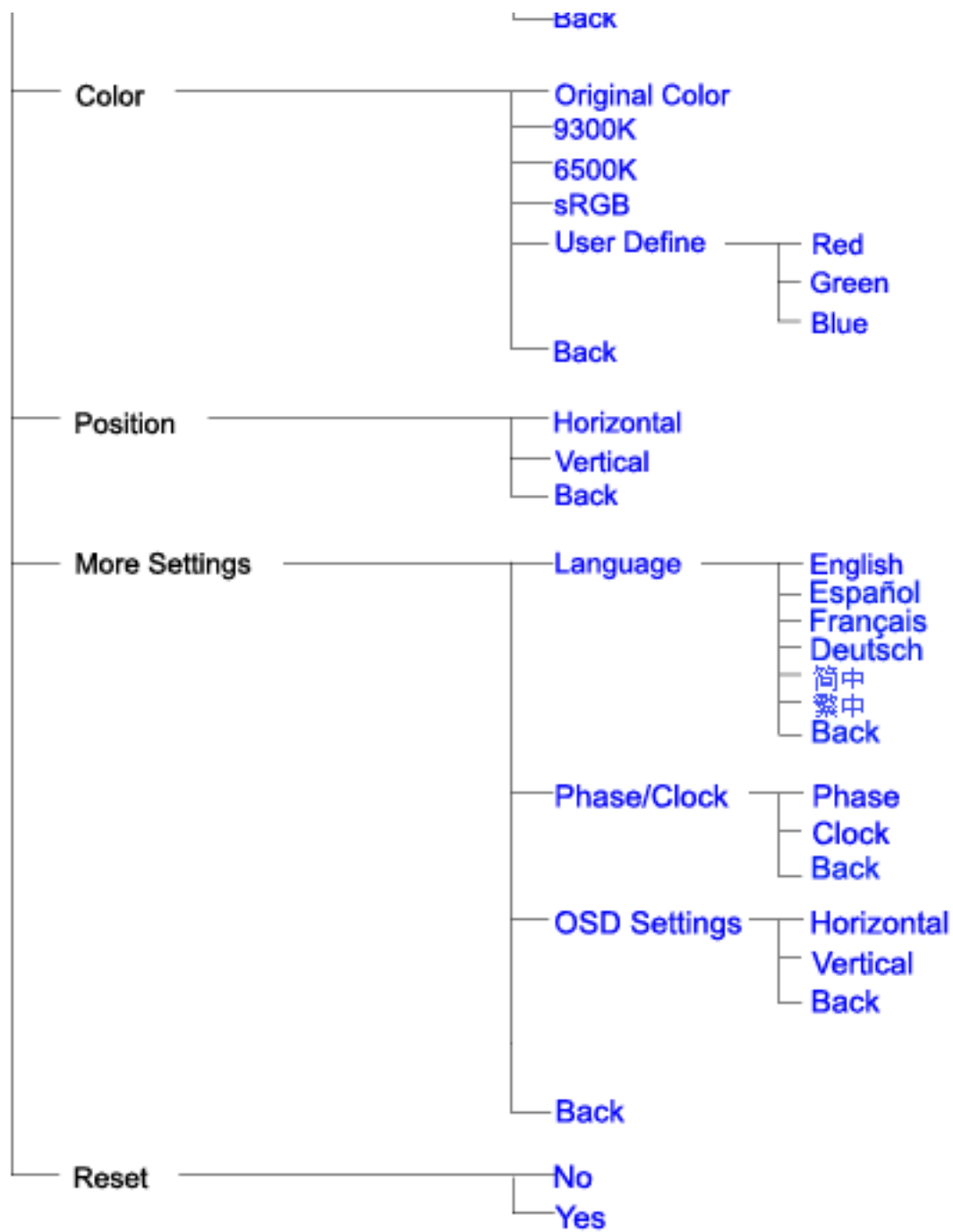

가

가/

- : • • • • • • • • • • • •
 - : • 가 • • • • • • • • • •
 - : • • • • • • • • • • • •
 - : •
 - : •
 - : • • • • • • • • • • • 가 • •
 - : •
 - : •
-

Philips F1rst Choice

Philips



Philips
F1rst Choice

3

Philips

Philips

가
48

Philips

Philips F1rst Choice

가

3

Philips

3

Philips F1rst Choice

가

Philips F1rst Choice

가

Philips F1rst Choice 가 Philips 가 Philips F1rst Choice

가 www.philips.com/support

www.philips.com/support Philips

Philips

Philips
Philips

PC

- o 286/386/486/Pentium Pro/
- o (Windows, DOS, OS/2, Apple Macintosh)
- o / /

Philips . F1rst Choice

: <http://www.philips.com/support>

Philips F1rst Choice ()



F1rst Choice
가 48
2 3 가
5

()

Click here to access the [Warranty Registration Card](#).

/ /1 *

* 가 () 2 3

가
가

/ . , / .

:

, ' , 가 .
/ ,
(,)
가 ,

가

가 가 (가) 가 가

: (877) 835-1838 () (919) 573-7855.

...

, ...

(877) 835-1838

(919) 573-7855

(, , .)

:

(800) 479-6696

(, , , 가)
... ()

MODEL # _____

SERIAL # _____

가

가

PC ()

- o 286/386/486/Pentium Pro/
- o (, DOS, OS/2, Apple Macintosh)

o Fax/ /

: , , .

()

8 9 (~) 10 5

: <http://www.philips.com>

A B C D E F G H I J K L M N O P Q R S T U V W X Y Z

A

Active matrix()

/ 가 LCD() . TFT() .

Amorphous silicon(, a-Si)

LCD (TFT) .

Aspect ratio(가)

16:9 16:10 가 . 가 4:3 . TV 가

가

B

Backlight()

(transmissive) LCD LCD 가 TFT LCD CCFL((diffuser panel) (Light Emitting Diode, LED)

Brightness()

가 . ()

가

C

CCFL(cold cathode fluorescent light,)

LCD . 2 mm 가 .

Chromaticity()

2

CIE(Commission International de l'Eclairage,)

Color temperature()

가 가 (: 9300°K). 6504°K () . Philips 가 (: 9300°K, 6500°K

Contrast()

Contrast ratio()

가 가

가

D

D-SUB(D-)

VGA . D-

가

E

Energy Star Computers Programme(Energy Star)

(<30W) 가 (EPA)

가

G

Gamma()

Grayscale()

가 8

$$2^8 = 256$$
$$256 \times 256 \times 256 = 16.7$$

R.G.B.

256

가

H

Hue()

가

I

IPS(In Plane Switching,)

LCD

LCD

가

L

LCD(liquid crystal display,)

. , / .

Liquid crystal()

. 가 LCD " " "

Luminance()

/ (cd/m2) (ftL) . 1 ftL = 3.426 cm/m2.

가

N

Nit()

1 cd/m2 0.292 ftL .

가

P

Pixel(,)

CRT LCD

Polarizer()

90 . LCD

가

가

R

Refres rate()

Hz 60 1

Hz() . 60

가

S

sRGB

sRGB (: , ,)

sRGB sRGB sRGB 가 Philips

sRGB 가
OSD sRGB

'sRGB' OSD OSD

가 sRGB 6500K

가

T

TFT(thin film transistor,)

(a-Si)

LCD

가

V

Vertical refresh rate()

Hz , () .

가

