

Register your product and get support at

www.philips.com/welcome

6100 Series

43PFT6100S/70

49PFT6100S/70

55PFT6100S/70

User manual

Panduan pengguna

Diproduksi oleh:
PT.TRIDHARMA KENCANA
JL. K.H ZAINUL ARIFIN NO.1
JAKARTA PUSAT

No Pendaftaran Petunjuk Penggunaan
dan Kartu Garansi:

P.32.TDK4.02104.0316

PHILIPS

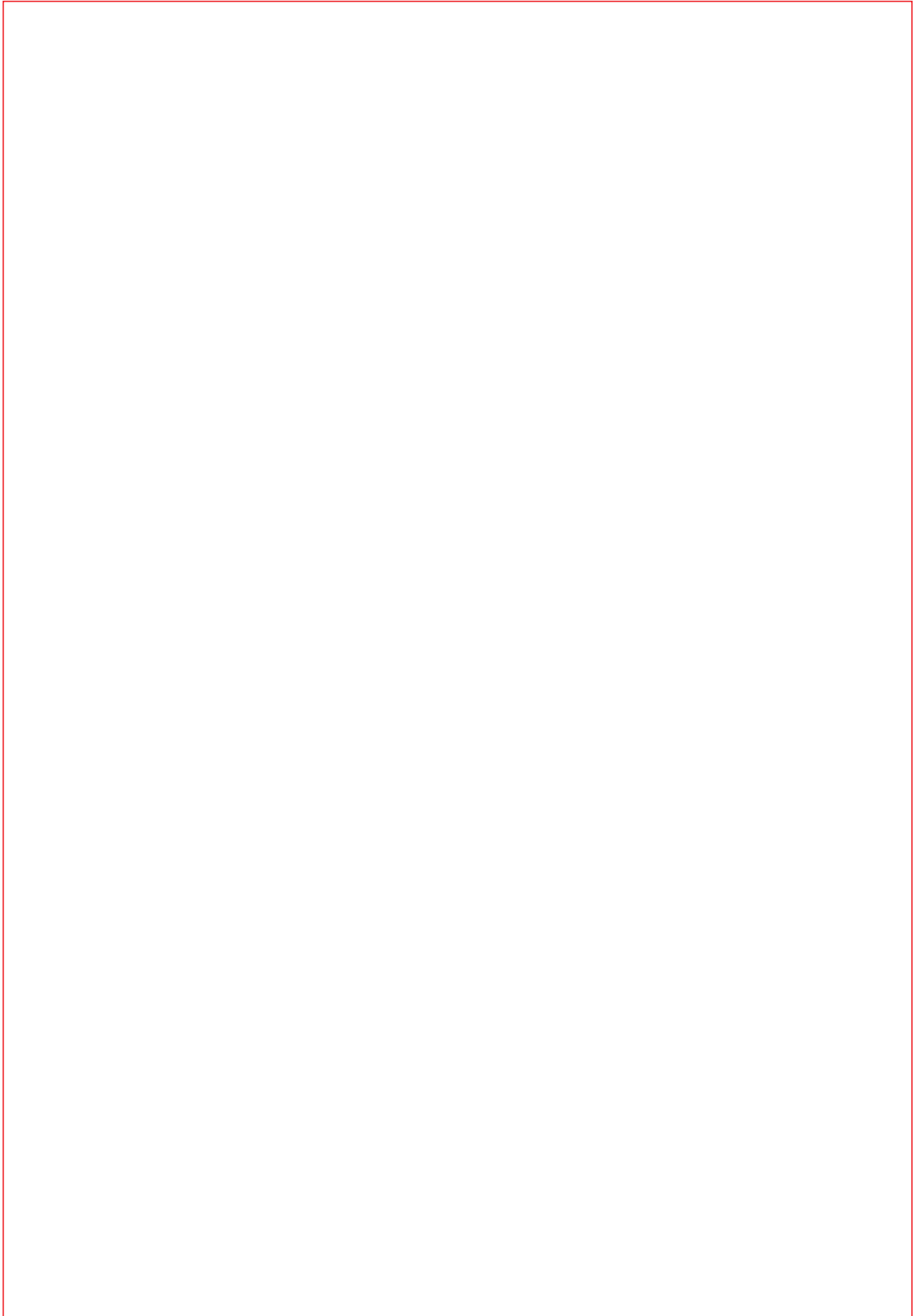

Contents

1	Caution	2
2	Important	3
3	Your TV	6
	Control Panel.....	6
	Remote Control.....	6
	Remote control usage.....	8
4	Use your TV	9
	Turn on/off the TV, or switch to Standby.....	9
	Switch Channels.....	10
	View Connected External Devices.....	10
	Use the SOURCE Button.....	10
	Adjust TV Volume.....	10
5	More TV Functions	11
	TV Menu.....	11
	Language.....	11
	Picture and Sound Settings.....	11
	Clock.....	13
	Other TV Settings.....	13
	Software Settings.....	14
	Channel Settings.....	15
	Network Configuration.....	16
	Parental Control.....	18
	Play Pictures, Music and Videos Stored in USB Device	19
6	Product information	19
	Multimedia.....	20
	Sound power.....	20
	Inherent resolution	20
	Tuner / Reception / Transmission.....	20
	Remote Control.....	20
	Power Supply	20
	Supported TV mounts.....	20
	Product Specification.....	21
7	Troubleshooting	21
	General issues.....	21
	Channel issues.....	22
	Picture issues	22
	Sound issues.....	22
	HDMI connection issues.....	22
	Computer connection issues.....	23
	Contact us.....	23

1 Caution

2016 ©TP Vision Europe B.V. All rights reserved. Specifications are subject to change without notice. Trademarks are the property of Koninklijke Philips N.V or their respective owners. TP Vision Europe B.V. reserves the right to change products at any time without being obliged to adjust earlier supplies accordingly.

The material in this manual is believed adequate for the intended use of the system. If the product, or its individual modules or procedures, are used for purposes other than those specified herein, confirmation of their validity and suitability must be obtained. TP Vision Europe B.V. warrants that the material itself does not infringe any United States patents. No further warranty is expressed or implied.

TP Vision Europe B.V. cannot be held responsible neither for any errors in the content of this document nor for any problems as a result of the content in this document.

Errors reported to Philips will be adapted and published on the Philips support website as soon as possible.

Terms of warranty

- Risk of injury, damage to TV or void of warranty! Do not attempt to repair the TV yourself.
- Use the TV and accessories only as intended by the manufacturer.

- The caution sign printed on the back of the TV indicates risk of electric shock. Never remove the TV cover. Always contact Philips Customer Support for service or repairs.



Any operation expressly prohibited in this manual, or any adjustments and assembly procedures not recommended or authorised in this manual shall void the warranty.

Pixel characteristics

This LCD/LED product has a high number of color pixels. Although it has effective pixels of 99.999% or more, black dots or bright points of light (red, green or blue) may appear constantly on the screen. This is a structural property of the display (within common industry standards) and is not a malfunction.

Mains fuse (/56)

This TV is fitted with an approved moulded plug. Should it become necessary to replace the mains fuse, this must be replaced with a fuse of the same value as indicated on the plug (example 10A).

- 1 Remove fuses cover and fuse.
- 2 The replacement fuse must comply with BS 1362 and have the ASTA approval mark. If the fuse is lost, contact your dealer in order to verify the correct type.
- 3 Refit the fuse cover.

Copyright



®Kensington and Micro Saver are registered US trademarks of ACCO World corporation with issued registrations and pending applications in other countries throughout the world.



HDMI, the HDMI logo and High-Definition Multimedia Interface are trademarks or registered trademarks of HDMI licensing LLC in the United States and other countries. All other registered and unregistered trademarks are the property of their respective owners.

2 Important

Read and understand all instructions before you use your TV. If damage is caused by failure to follow instructions, the warranty does not apply.

Safety

Risk of electric shock or fire!

- Never expose the TV to rain or water. Never place liquid containers, such as vases, near the TV. If liquids are spilt on or into the TV, disconnect the TV from the power outlet immediately. Contact Philips Consumer Care to have the TV checked before use.
- Never place the TV, remote control or batteries near naked flame or rather heat sources, including direct sunlight. To prevent the spread of fire, keep candles or other flames away from the TV, remote control and batteries at all times.



- Never insert objects into the ventilation slots or other openings on the TV.
- When the TV is swiveled ensure that no strain is exerted on the power cord. Strain on the power cord can loosen connections and cause arcing.
- To disconnect the TV from the mains power,

the power plug of the TV must be disconnected. When disconnecting the power, always pull the power plug, never the cord. Ensure that you have full access to the power plug, power cord and outlet socket at all times.

Risk of short circuit or fire!

- Never expose the remote control or batteries to rain, water or excessive heat.
- Avoid force coming onto power plugs. Loose power plugs can cause arcing or fire.

Risk of injury or damage to the TV!

- Two people are required to lift and carry a TV that weighs more than 25 kg or 55 lbs.
- When stand mounting the TV, use only the supplied stand. Secure the stand to the TV tightly. Place the TV on a flat, level surface that can support the combined weight of the TV and the stand.
- When wall mounting the TV, use only a wall mount that can support the weight of the TV. Secure the wall mount to a wall that can support the combined weight of the TV and wall mount. TP Vision Europe B.V. bears no responsibility for improper wall mounting those results in accident, injury or damage.
- If you need to store the TV, disassemble the stand from the TV. Never lay the TV on its back with the stand installed.
- Before you connect the TV to the power outlet, ensure that the power voltage matches the value printed on the back of the TV. Never connect the TV to the power

outlet if the voltage is different.

- Parts of this product may be made of glass. Handle with care to avoid injury and damage.

Risk of injury to children!

Follow these precautions to prevent the TV from toppling over and causing injury to children:

- Never place the TV on a surface covered by a cloth or other material that can be pulled away.
- Ensure that no part of the TV hangs over the edge of the surface.
- Never place the TV on tall furniture (such as a bookcase) without anchoring both the furniture and TV to the wall or a suitable support.
- Educate children about the dangers of climbing on furniture to reach the TV.

Risk of swallowing batteries!

- The product/remote control may contain a coin-type battery, which can be swallowed. Keep the battery out of reach of children at all times!

Risk of overheating!

- Never install the TV in a confined space. Always leave a space of at least 4 inches or 10 cm around the TV for ventilation. Ensure curtains or other objects never cover the ventilation slots on the TV.

Risk of injury, fire or power cord damage!

- Never place the TV or any objects on the power cord.
- Disconnect the TV from the power outlet and antenna before lightning storms.

During lightning storms, never touch any part of the TV, power cord or antenna cable.

Risk of hearing damage!

- Avoid using earphones or headphones at high volumes or for prolonged periods of time.

Low temperatures

- If the TV is transported in temperatures below 5°C or 41°F, unpack the TV and wait until the TV temperature matches room temperature before connecting the TV to the power outlet.

Screen care

- Avoid stationary images as much as possible. Stationary images are images that remain on-screen for extended periods of time. Example: on screen menus, black bars and time displays. If you must use stationary images, reduce screen contrast and brightness to avoid screen damage.
- Unplug the TV before cleaning.
- Clean the TV and frame with a soft, damp cloth. Never use substances such as alcohol, chemicals or household cleaners on the TV.
- Risk of damage to the TV screen! Never touch, push, rub or strike the screen with any object.
- To avoid deformations and color fading, wipe off water drops as soon as possible.

Recycling



Your product is designed and manufactured with high quality materials and components, which can be recycled and reused.



When this crossed-out wheeled bin symbol is attached to a product it means that the product is covered by the European Directive 2002/96/ EC. Please inform yourself about the local separate collection system for electrical and electronic products.

Please act according to your local rules and do not dispose of your old products with your normal household waste.

Correct disposal of your old product helps to prevent potential negative consequences for the environment and human health.



Your product contains batteries covered by the European Directive 2006/66/EC, which cannot be disposed of with normal household waste. Please inform yourself about the local rules on separate collection of batteries because correct disposal helps to prevent negative consequences for the environment and human health.

3 Your TV

Congratulations on your purchase, and welcome to Philips! To fully benefit from the support that Philips offers, register your TV at www.philips.com/welcome.

(The following machine picture only for reference, please refer to the actual object.)

Control Panel

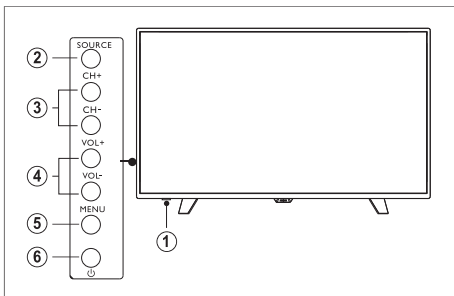

1. Indicator/Remote Control Sensor
2. Source: display the list of signal sources.
3. CH +/-: switch to the previous/ next channel.
4. VOL +/-: increase/reduce the volume.
5. Menu: turn on/off the main menu.
6. **⏻** : turn on/off the TV; to cut off power supply, please unplug the power cable.

Remote Control

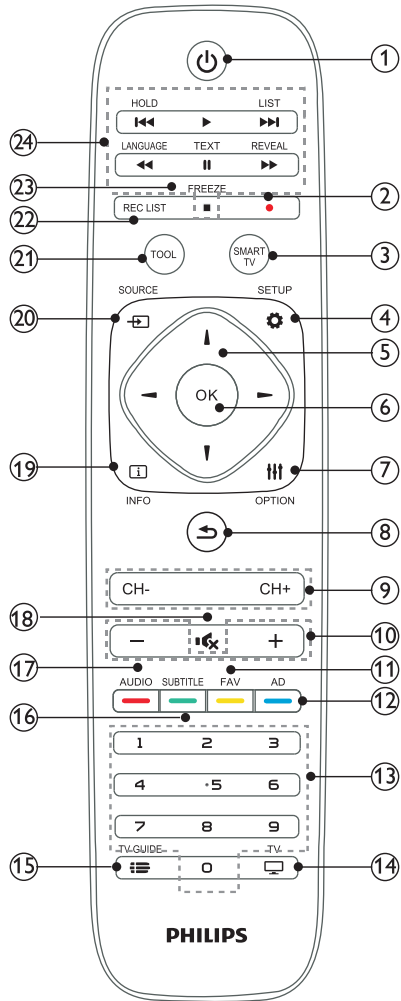



① Standby/Power On

- Switch to Standby mode when the TV is powered on.
- Power on the TV when it is in standby mode.

② Recording

Before recording, get ready by following the steps below:

1. Connect a formatted USB hard drive to the TV.
 2. Make sure TV channels are available on the TV.
- To record TV programs, press the **Red ** (recording) button on the remote control.
 - To record TV programs at a scheduled time, press the **TV Guide** button, select the TV program to be recorded, and press the Red  (recording) button on the remote control to schedule a recording time.

③ Smart TV

Enter the Smart TV homepage.

④ SETUP

Open or close the Setup menu.

⑤ Navigation Keys

- In menu mode: navigate the menus.

⑥ OK

- In menu mode: confirm input or selection.

⑦ OPTION

View options related to the current activity or selection.

⑧ Return

Return to the previous channel

⑨ CH+/-

Switch to the previous or next channel.

⑩ VOL+/-

Increase or decrease the volume.

⑪ FAV

Favorite channel list.

⑫ AD

Shortcut key for Audio Description.

⑬ Numeric Keys 0-9

Select a channel or input a channel number.

⑭ TV

Switch to TV mode.

⑮  **TV GUIDE (Electronic Program Guide)**

Instant access to EPG.

- Contact your broadcasting service provider or operator for availability of EPG.

⑯ **SUBTITLE**

When subtitle is available on the current channel, press the **Green** (Teletext) button to display the subtitle.

⑰ **AUDIO**

Shortcut key for audio language selection.

⑱ 

Mute or unmute the sound.

⑲  **INFO**

Display the available program information.

⑳  **SOURCE**

Select an input source for the TV.

㉑ **TOOL**

Open or close the Tool menu.

㉒ **REC LIST**

View the recording list.

㉓  **FREEZE**

Freeze the image of TV program.

Press this button again to return to the TV program.

㉔ 

Shortcut keys under the USB mode:

Previous, Fast Reverse, Play, Pause, Stop, Fast Forward, Next.

Remote control usage

When you use the remote control, hold it close to the TV and point it at the remote control sensor. Make sure that the line-of-sight between the remote control and TV is not blocked by furniture, walls or other objects.

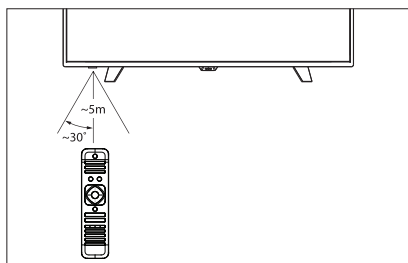

4 Use your TV

This chapter describes the basic TV operations.

Turn on/off the TV, or switch to Standby

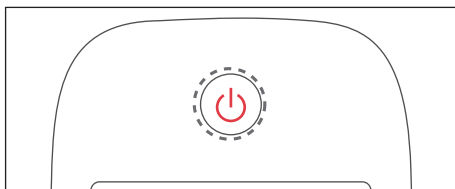
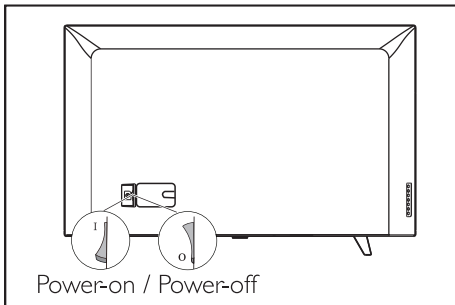
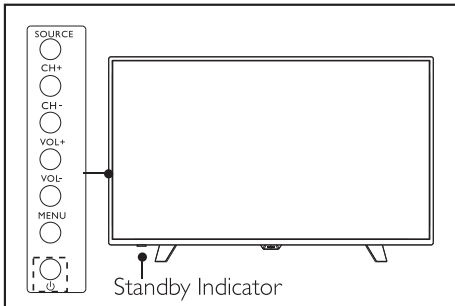

Turn on the TV

- If the indicator is off, please insert the TV power cord into a power outlet. Press the power switch to turn on the TV as shown in the figure.
- When the indicator is on, press the  (Standby-On) button on the remote control or on the side of TV to turn on the TV.

Switch to Standby

- Press the  (On-Standby) button on the remote control.
 - ↳ The Standby Indicator turns on.

Turn off the TV

- Press the power switch to turn off the TV as shown in the figure.
 - ↳ The Standby Indicator turns off.

Tip

- The TV still consumes a little power in Standby mode. If it will be idle for long period, please disconnect the power plug from the power outlet to save power.

Switch Channels

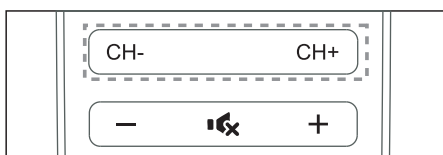
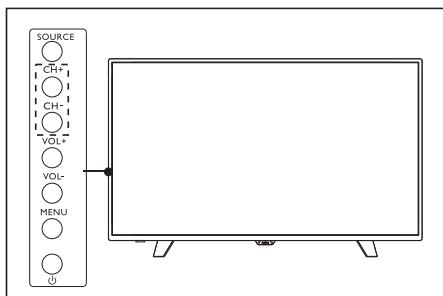

- Press the **CH+/-** button on the remote control or on the lower right side of the TV.
- Press the numeric keys on the remote control to input the channel number.
- Press the **↶** button on the remote control to switch and return to the previous channel.

View Connected External Devices

Note

- Before selecting an external signal source, please turn on the connected external devices.

Use the SOURCE Button

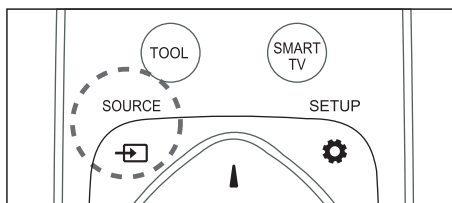

1. Press the **SOURCE** button.
 - » The signal source list is displayed.
2. Press the **▼▲** buttons to select a device.
3. Press the **OK** button to confirm.
 - » The input source is switched to the selected device.

Adjust TV Volume

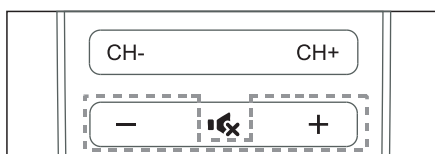
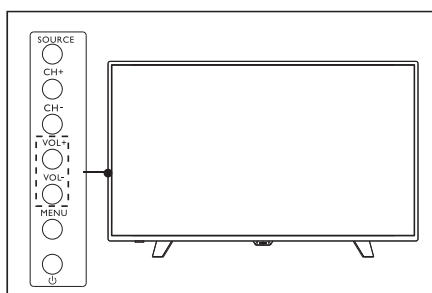

Increase / decrease the volume

- Press the **VOL+/-** button on the remote control or on the lower right side of the TV. Mute or unmute the sound.
- Press the **🔇** (Mute) button to disable sound.
- Press the **🔇** button again to unmute the sound.

5 More TV Functions

As the product and software are subject to continuous upgrade, the actual software operations may vary from descriptions in this manual.

TV Menu

You can set up channels, picture, and sound in the TV menu and it also provides access to other functions.

1. Press the **TOOL** button.
↳ The menu is displayed.



2. Select an option and press the “OK” button:
 - [Smart TV]: Enter the Smart TV homepage.
 - [TV]: When the current signal source is not TV, select this option to switch to TV program.
 - [Source]: Select from connected external devices.
 - [Settings]: Set up TV, channel, network, software settings.

Language

You can set up the menu language.

Set the menu language

1. Press the SETUP button.
2. Select [TV Settings] > [Preference] > [Menu Language], and press the button.
3. Select the language you want and press the “OK” button.

Picture and Sound Settings

You can configure the picture and sound settings to suit your preference.

You can use the predefined settings or manually change the settings.

Intelligent Picture

Select the predefined picture settings for the Intelligent Picture.

1. Press the SETUP button.
2. Select [TV Settings]> [Picture] > [Intelligent Picture].
3. Select an option and press the “OK” button.
 - [Standard]: This mode is suitable for most of the occasions and video formats.
 - [Natural]: Adopt natural picture quality.
 - [Vivid]: Adopt colorful and dynamic

picture settings suitable for viewing in daylight.

- [Customized]: Adopt the customized settings.

Manual Picture Settings

1. Press the  SETUP button.
2. Select [TV Settings] and press the "OK" button.
3. Select [Picture], select an option and press the ► button.
 - [Intelligent Picture]: Select predefined settings.
 - [Contrast]: Adjust the contrast between the bright and dark areas (0-100).
 - [Brightness]: Adjust the brightness and fineness of the picture (0-100).
 - [Sharpness]: Adjust the definition of the picture (0-100).
 - [Saturation]: Adjust the color saturation (0-100).
 - [Color Temperature]: Set the color temperature of the picture to Cool, Standard and Warm.
 - [Display Format]: Adjust the aspect ratio of the picture.
 - [Noise Reduction]: Reduce the noises in the picture.

Aspect Ratio





1. Press the  SETUP button.
2. Select [TV Settings] > [Picture] > [Aspect Ratio] and press the ► button.

About Aspect Ratio

The following settings are available.



Note

<ul style="list-style-type: none">• Some picture settings may be unavailable, depending on the signal source of the picture.	
	[Wide Screen]: Adjust the screen to the Wide Screen mode.
	[4:3]: Display the screen in 4:3 format.
	[16:9]: (Not suitable for PC mode.) Adjust 4:3 format to 16:9 format.
	[Scaled-up Subtitle]: (Not suitable for HD and PC mode.) Display the screen in 4:3 format, but the top of the screen is cropped so as to display the subtitle.

Set the Intelligent Sound

Select the predefined sound settings for the Intelligent Sound.

1. Press the  SETUP button. Select [TV Settings] > [Sound] > [Intelligent Sound].
2. Select an option and press the "OK" button.
 - [Standard]: This mode is suitable for most of the occasions and audio formats.

[News]: This mode is suitable for news programs.

[Cinema]: This mode is suitable for watching movies.

[Customized]: Configure your customized sounding settings.

Manual Sound Settings

Press the  SETUP button.

Select [TV Settings] and press the "OK" button.

Select [Sound], select an option and press the  button.

[Intelligent Sound]: Select the predefined settings.

[Bass]: Adjust the bass (0-100).

[Treble]: Adjust the treble (0-100).

[Balance]: Adjust the balance between the left and right speakers (R50-L50).

[Surround]: Turn on the surround sound.

[SPDIF Output]: Select digital audio output mode: PCM or RAW.

[AD Switch]: Turn on/off audio description (only available in specific mode).

Clock

1. Press the  SETUP button.
2. Select [TV Settings] > [Preference] > [Clock] The clock displays the network time or synchronizes with the time in code stream.

Sleep Timer

You can set a sleep timer to switch your TV to Standby mode at the preset time.

Note

- You can turn off the TV manually, or you can reset the sleep timer before the countdown ends.

1. Press the  SETUP button.
2. Select [TV Settings] > [Preference] > [Sleep Timer] and press the "OK" button.
3. Set the timer to a value between 0 min and 240 min.
4. Press the "OK" button to start the timer.
 - ↳ When the preset time goes out, the TV switches to Standby mode.

Other TV Settings

You can change other TV settings.

Factory Settings

1. Press the  SETUP button.
2. Select [TV Settings] > [Factory Settings] and press the "OK" button.

3. Select [Reset] and press the "OK" button to restore to the default factory settings, but the channel settings will not be restored.

Reset the TV

1. Press the  SETUP button.
2. Select [TV Settings] > [Reset the TV] and press the "OK" button.
3. Select [Reset] and press the "OK" button to reset all the settings and channels.

PVR

1. Press the  SETUP button.
2. Select [TV Settings] > [PVR File System] and press the "OK" button to enter.
3. Press the "OK" button after you finish the settings.

OAD Settings

Only available in specific mode.

1. Press the  SETUP button.
2. Select [TV Settings] > [OAD Settings] > [On] to open the menu.
3. Select to set the scanning time, OAD scanning, and update prompt on/off, then press the "OK" button to finish the settings.

Software Settings

Philips is committed to continuously improving our products. We recommend that

you should upgrade your TV software when an update is available.

App Management

1. Press the  SETUP button.
2. Select [Software Settings] > [App Management] and press the "OK" button.
 - [App Settings]: Set the installation path for apps.
 - [All Apps]: View all the apps installed in the system.
 - [Apps in USB Device]: View all the apps stored in the USB device.

Software Info

1. Press the  SETUP button.
2. Select [Software Settings] > [Software Info] and press the "OK" button.
 - View relevant information about the current software version.

Local Update

1. Press the  SETUP button.
2. Select [Software Settings] > [Local Update] and press the "OK" button.
3. Update the software following the on-screen prompts.

Note

- Before operation, please insert the USB device containing the update package.

Channel Settings

When you first turn on your TV, it will prompt you to set up menu language, auto channel scan and network.

Auto Scan



1. Press the  SETUP button.
2. Select [Channel Settings] > [Auto Scan] and press the "OK" button.
3. Select the applicable system and the country you are located.

ATV Manual Scan

Before scanning, please switch the signal source to ATV.

1. Press the  SETUP button.
2. Select [Channel Settings] > [Manual Scan] and press the "OK" button.
3. Select the applicable [Color System] and [Sound System].

Search for and Save Channels



1. Press the  SETUP button.
2. Select [Channel Settings] > [Manual Scan] > [Scan] and press the "OK" button.
 - Select [Scan] and press the  buttons to search for channels.
3. When you finish scanning, select [Save] and press the "OK" button to save the searched channel as the current channel.



Note



- In ATV mode, press the "OK" button to display the saved channels.

Fine Tuning

1. Press the  SETUP button.
2. Select [Channel Settings] > [Manual Scan] > [Fine Tuning] and press the "OK" button.
3. Press the  buttons to fine tune channels. Select [Finish] to exit the menu.



TV Manual Scan

Before scanning, please switch the signal source to TV.

1. Press the  SETUP button.
2. Select [Channel Settings] > [Manual Scan] and press the "OK" button to start scanning.
3. Press the  buttons to adjust channels. Select [Finish] to exit the menu.

EPG

Only available in specific mode.

1. Press the " TV GUIDE" button.
2. Press the   buttons to select time and channel.
3. Press the colored buttons to view program list, set program notifications, etc.

Network Configuration

You can configure different network connections to access different networks.

Smart TV

1. Connect your TV to the Internet. If network connection is unavailable, some functions of Smart TV cannot work.
2. Press the "SMART TV" button on the remote control.
 - ↳ The screen auto enters the Smart TV homepage.



Interface Description

	<p>TV: A preview of the current TV program.</p>
	<p>App List: Display all the apps installed in the system.</p>
	<p>Signal Source: Select a signal source from the connected external devices.</p>
	<p>Settings: Open the setting menu.</p>

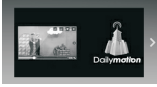

App Recommendation:
Tap an app that you want to download it from the App Store.

Note

- Philips reserves the right to add or remove apps. Please do not alter the TV ROM without authorization, and any damages arising therefrom shall not be covered by the warranty. To improve user experience, connect an external mouse for easier operation.

Network Status

You can select the network type.

1. Press the SETUP button.
2. Select [Network Configuration] > [Network Status].
 - ↳ The screen displays the current network parameters.

Wired Network

To connect the TV to the Internet via PC, your PC must be equipped with a router. Connect the router to the network port on the TV using a network cable (Ethernet cable). Turn on the router before network configuration.

Wired Network Configuration - Auto

Settings

1. Press the  SETUP button.
2. Select [Network Configuration] > [Wired Network] and press the "OK" button.
3. Select [Auto obtain IP address/On].
 - ↳ The network protocol is automatically configured.

-
1. Press the  SETUP button.
 2. Select [Network Configuration] > [Wired Network] and press the "OK" button.
 3. Select [Auto Obtain IP Address/Off].
 4. Press the numeric keys to input the values of [IP Address], [Subnet Mask], [Default Gateway], [Primary DNS] and [Secondary DNS].
 5. After inputting the values, select [Save] and press the "OK" button.

Wireless Network

You can set up a Wi-Fi network to connect your TV to the Internet.

Wireless Network Configuration

1. Press the  SETUP button.
2. Select [Network Configuration] > [Wireless Network] and press the "OK" button.
3. Select [Wi-Fi/On], and the following options are displayed:
 - [SSID]: View all the Wi-Fi signal sources searched by the TV. For an encrypted

network, you have to input the correct password to join the network.

- [Auto Obtain IP Address]: Enable or disable the auto obtaining of IP address. The operations are the same as those described in wired Network Configuration.

SAMBA File Sharing

1. In Smart TV mode, select [Media Player Center] > [SAMBA File Sharing] and press the "OK" button. The system auto searches for users on the network.
2. Select one network IP address and press the "OK" button. Input the correct user name and password to view and play the files shared on the SAMBA server.



Note

- The PC and TV shall be on the same LAN with their IP addresses in the same segment;
- The shared PC shall disable the firewall and set to share the folder;
- The PC must support domain name system;
- Depending on network environment and speed, the playback of HD videos may not be fluent sometimes, which is a normal phenomenon, not a fault.

PPPOE Settings

Through this function, the TV can be directly connected to ADSL via a network cable, so as to access the Internet over PPPOE.

1. Press the  SETUP button.

2. Select [Network Configuration] > [PPPOE Settings] and press the ► button.
3. Finish the following settings, then press the "OK" button to select [Dial Up] or [Hang Up].
 - [User Name]: Input the user name offered by your Internet service provider.
 - [Password]: Input the user password.
 - [Display Password]: Enable or disable the display of password.
 - [Auto Dial Up]: Enable or disable auto dial up.

Wi-Fi Access Point

Enable the TV to become an access point of the wireless network.

1. Press the  SETUP button.
2. Select [Network Configuration] > [Wi-Fi Access Point] and press the ► button.
3. Select an option:
 - [Wi-Fi Access Point]: Enable or disable the Wi-Fi access point.
(Turn off the Wi-Fi before operation)
 - [Configure Wi-Fi Access Point]: After enabling the access point, you can set up options such as SSID, security, password. After settings, select [Save] and press the "OK" button.

Parental Control

The parents can restrict the use of this TV by children on the basis of TV program ratings.

1. Press the  SETUP button.

2. Select [TV Settings] > [Parental Control] > [System Lock] and press the "OK" button. Input the initial password "0000" to enter the menu.
3. Select On or Off.
4. Select to set an option:
 - [Change Password]: To change the password, you need to input the old password, the new password and confirm the new password. Select [Confirm] and press the "OK" button.
 - [Lock Program]: Press the "Green" button to lock or unlock the programs as required.
 - [Set Rating]: Press the "OK" button to set the TV program rating.



Note

- It requires password to change the system settings.
- When system lock is disabled, the following options cannot be selected: [Change Password]; [Lock Program]; [Set Rating].

Play Pictures, Music and Videos Stored in USB Device

Video format supported by USB device:

Supported storage device: USB device (only support FAT or FAT 32 USB storage devices)

Supported multimedia formats:

Image: JPEG

Audio: MP3

Video: MPEG1/MPEG2/H.264

(The above formats are for reference only)



Note

We shall not be held liable for any incompatible USB devices and any data damage or loss from such devices.

Play Pictures, Music and Videos via the Connected USB Device

1. Turn on the TV.
2. Connect the USB storage device to the USB port on the side of the TV.
3. Press the "SOURCE" button on the remote control to select USB and press the "OK" button; or, press the "SMART TV" button on the remote control to select "Media Player Center" from App and press the "OK" button.
4. Press the "◀" button to select from file types shown on the left of the screen: [All], [Picture], [Music], [Movie]. Press the "OK" button to select and press the "▶" button to enter [Local Disk]. Press the "OK" button to enter the folder, press the "▲▼" buttons to select the file, and press the "OK" button to play.

6 Product information

Product information is subject to change without notice. For detailed product information, please visit www.philips.com/support.

Display resolutions

Computer Formats

- Resolution - refresh rate:
 - 640 × 480 - 60Hz
 - 800 × 600 - 60Hz
 - 1024 × 768 - 60Hz
 - 1360 × 768 - 60Hz
 - 1920 × 1080 - 60Hz

Video Formats

- Resolution - refresh rate:
 - 480i - 60Hz
 - 480p - 60Hz
 - 576i - 50Hz
 - 576p - 50Hz
 - 720p - 50Hz, 60Hz
 - 1080i - 50Hz, 60Hz
 - 1080p - 50Hz, 60Hz.

Multimedia

- Supported storage device: USB (only FAT or FAT 32 USB storage devices are supported.)
- Compatible multimedia file formats:
 - Image: JPEG
 - Audio: MP3
 - Video: MPEG 2/MPEG 4, H.264

Sound power

- 43": 8W×2
- 49": 8W×2
- 55": 8W×2

Inherent resolution

- 43" : 1920 × 1080
- 49" : 1920 × 1080
- 55" : 1920 × 1080

Tuner / Reception / Transmission

- Aerial input: 75ohm coaxial (IEC75)
- Supported Systems:
ATV: PAL D/K, I, B/G, NTSC M,
SECAM D/K, B/G, L

Remote Control

- Batteries: 2 × AAA

Power Supply

- Main Power Supply:
100-240V~, 50/60Hz
- Standby Energy Consumption:
≤0.5W
- Environment Temperature: 5-40°C
- Power consumption:
43": 75W
49": 110W
55": 130W

Supported TV mounts

To mount the TV, please purchase a Philips TV mount or any TV mount compliant with the VESA standard. To prevent damage to cables and connectors, be sure to leave a clearance gap of at least 2.2 inches or 5.5cm between the back of the TV to the wall.



Warning

- Please follow all instructions provided with the TV mount. TP Vision Europe B.V. bears no responsibility for improper TV mounting those results in accident, injury or damage.

Model No.	Required Pixel Pitch (mm)	Required Mounting Screws
43"	200 × 300	4 × M6
49"	200 × 300	4 × M6
55"	200 × 300	4 × M6

Product Specification

The product design and specification are subject to change without further notice.

43"

- Without base
- Dimension (W×H×D)
970×564×74 (mm)
- Weight: 8.3 Kg

- With base
- Dimension (W×H×D)
970×614×219 (mm)
- Weight: 8.5 Kg

49"

- Without base
- Dimension (W×H×D)
1102×639×81 (mm)
- Weight: 9.5 Kg

- With base
- Dimension (W×H×D)
1102×696×258 (mm)
- Weight: 10.0 Kg

55"

- Without base
- Dimension (W×H×D)
1243×720×81 (mm)
- Weight: 13.5 Kg

- With base
- Dimension (W×H×D)
1243×776×258 (mm)
- Weight: 14.0 Kg

7 Troubleshooting

This section covers common problems and their accompanying solutions.

General issues

The TV cannot be switched on:

- Disconnect the power cable from the power outlet. Wait for one minute before reconnecting it.
- Check that the power cable is securely connected.

The remote control is not working properly:

- Check that the remote control batteries are correctly inserted according to the +/- orientation.
- Replace the remote control batteries if they are flat or weak.
- Clean the remote control and TV sensor lens.

The TV menu is in the wrong language.

- Change the TV menu to your preferred language.

When turning the TV On/Off or to Standby, you hear a creaking sound from the TV chassis:

- No action is required. The creaking sound comes from the normal expansion and contraction of the TV as it cools down and warms up. This does not impact its performance.

Channel issues

Previously installed channels do not appear in the channel list:

- Check that the correct channel list is selected.

Picture issues

The TV is on, but there is no picture:

- Check that the antenna is properly connected to the TV.
- Check that the correct device is selected as the TV source.

There is sound but no picture:

- Check that the picture settings are correctly set.

Poor TV reception from the antenna connection:

- Check that the antenna is properly connected to the TV.
- Loudspeakers, unearthed audio devices, neon lights, high buildings and other large objects can influence reception quality. If possible, try to improve the reception quality by changing the antenna direction or moving devices away from the TV.
- If the reception on one particular channel is poor, please fine tune this channel.

There is poor picture quality from connected devices:

- Check that the devices are connected properly.

- Check that the picture settings are correctly set.

The picture does not fit the screen; it is too big or too small:

- Try using a different picture format.

The picture position is incorrect:

- Picture signals from some devices may not fit the screen correctly. Please check the signal output of the device.

Sound issues

The pictures are showing but sound quality is poor:

- Check that all cables are properly connected.
- Check that the volume is not set to 0.
- Check that the sound is not muted.
- Check that the sound settings are correctly set.

The pictures are showing but sound comes from one speaker only:

- Verify that sound balance is set to the centre.

HDMI connection issues

There are problems with HDMI devices:

- Please note that HDCP (High-bandwidth Digital Content Protection) support can delay the time taken for a TV to display content from a HDMI device.
- If the TV does not recognize the HDMI

device and no pictures are displayed, please try switching the signal source to another device before switching it back again.

- If there are intermittent sound disruptions, please check that output settings from the HDMI device are correct.

Computer connection issues

The computer display on the TV is not stable:

- Check that your PC uses the supported resolution and refresh rate.
- Set the TV picture format to unscaled.

Network Connection Issues

Failure to connect to the Internet:

- If the TV is correctly connected to the router, please check the connection between the router and the Internet.

Network speed is slow

- Please refer to the instruction manual of your router to learn about the factors that may affect transfer rate and signal quality.
- You may need to upgrade your broadband speed.

Contact us

If you cannot resolve your problem, please refer to the FAQs for this model at www.philips.com/support.

If the problem remains unresolved, please contact your local Philips Customer Service Centre.



Warning

- Do not attempt to repair the TV yourself. This may cause severe injury, irreparable damage to your TV or void your warranty.



Note

- Please make a note of your TV model and serial number before you contact Philips Customer Service Centre. These numbers are printed on the back/bottom of the TV and on the packaging.