

Register your product and get support at  
[www.philips.com/welcome](http://www.philips.com/welcome)

22PFL3606

---

EN User manual

**PHILIPS**

## INSTRUCCIONES DE SEGURIDAD IMPORTANTE

### Lea antes de operar el equipo

1. Lea estas instrucciones.
2. Guarde estas instrucciones.
3. Preste atención a todas las advertencias.
4. Siga todas las instrucciones.
5. No use este aparato cerca del agua.
6. Límpielo solamente con un paño seco.
7. No bloquee ninguno de los orificios de ventilación. Instálelo de acuerdo con las instrucciones de los fabricantes.
8. No lo instale cerca de fuentes de calor, tales como radiadores, computuras de tiro (registros) de calor, estufas u otros aparatos (incluidos amplificadores) que generen calor.
9. No anule el objetivo de seguridad del enchufe polarizado o de conexión a tierra. Un enchufe polarizado tiene dos paletas, una más ancha que la otra. Un enchufe de conexión a tierra tiene dos paletas y una tercera espiga de conexión a tierra. La paleta más ancha o la tercera espiga es entregada para su seguridad. Si el enchufe suministrado no se ajusta a su tomacorriente, consulte a un electricista para que reemplace el tomacorriente obsoleto.
10. Evite pisar o apretar el cable de suministro eléctrico, especialmente en los enchufes, tomacorrientes y el punto en que salen del aparato.
11. Sólo use aditamentos o accesorios especificados por el fabricante.
12.  Utilice sólo un carro, soporte, trípode, repisa o mesa especificados por el fabricante o que se vendan junto con el aparato. Si usa el carro, tenga precaución cuando mueva la combinación carro/aparato para evitar lesiones si éste se vuelca.
13. Desenchufe este aparato durante las tormentas eléctricas o cuando no se use durante largos periodos.
14. Deje que personal calificado realice todo el servicio. Es necesario que el aparato reciba servicio si se ha dañado en algún modo, como cuando se daña el cable o enchufe de suministro de corriente, se ha derramado líquido u objetos han caído dentro él, cuando el aparato ha estado expuesto a lluvia o humedad, no opera bien o se ha caído.
15. Es posible que este producto contenga plomo y mercurio. La eliminación de estos materiales podría estar regulada debido a consideraciones medioambientales. Para obtener información acerca de la eliminación o del reciclaje, póngase en contacto con sus autoridades locales o con la Alianza de Industrias Electrónicas: en [www.eiae.org](http://www.eiae.org)
16. **Daños que requieran servicio** - El aparato debe recibir servicio de personal de servicio calificado cuando:
  - A. Se ha dañado el cable de alimentación o el enchufe; o
  - B. Han caído objetos o se ha derramado líquido dentro del aparato; o
  - C. El aparato ha quedado expuesto a la lluvia; o
  - D. El aparato parece no funcionar normalmente o su rendimiento ha cambiado notoriamente; o
  - E. Se ha dejado caer el aparato o se ha dañado la caja.
17. **Inclinación/estabilidad** - Todos los televisores deben cumplir con las normas de seguridad generales recomendadas internacionalmente en cuanto a las propiedades de inclinación y estabilidad del diseño de su gabinete.
  - No comprometa estas normas de diseño aplicando una fuerza de tracción excesiva a la parte delantera o superior del gabinete lo que finalmente puede hacer que el producto se vuelque.
  - Además, no se ponga en peligro usted mismo o a sus niños colocando equipos electrónicos o juguetes sobre el gabinete. Dichos artículos pueden caer inesperadamente desde la parte superior del producto y dañar el producto y/o causar lesiones personales.
18. **Montaje en la pared o cielorraso** - El aparato se debe montar en una pared o cielorraso únicamente como lo recomienda el fabricante.
19. **Líneas de energía eléctrica** - Una antena exterior se debe ubicar lejos de las líneas de energía.
20. **Conexión a tierra de la antena exterior** - Si se conecta una antena exterior o un sistema de cable al producto, asegúrese de que la antena o el sistema de cable estén conectados a tierra para proporcionar cierta protección contra sobrevoltajes y acumulación de cargas electrostáticas. En la Sección 810 del Código Eléctrico Nacional, ANSI/NFPA 70, se proporciona información sobre la adecuada conexión a tierra de las esteras y estructuras de apoyo, conexión a tierra del alambre de acometida a una unidad de descarga de antena, tamaño de los conectores de conexión a tierra, ubicación de la unidad de descarga de antena, conexión a los electrodos y requerimientos del electrodo de conexión a tierra. Vea la Figura que aparece más abajo.
21. **Entrada de objetos y líquidos** - Se debe tener cuidado de que no caigan objetos dentro de los orificios de la caja ni se derramen líquidos a través de ellos.
  - a) **Advertencia:** Para reducir el riesgo de incendios o de descarga eléctrica, este aparato no se debe exponer a la lluvia ni a la humedad, y no se le deben colocar encima objetos llenos de líquido como jarrones.
22. **Uso de las baterías PRECAUCIÓN** - Para evitar escapes de las baterías que pueden resultar en lesiones corporales, daño a la propiedad o a la unidad:
  - Instale correctamente todas las baterías, con los polos + y - alineados como está marcado en la unidad.
  - No mezcle las baterías (nuevas con antiguas o de carbono con alcalinas, etc.).
  - Retire las baterías cuando no use la unidad por un largo tiempo.

**Nota para el instalador del sistema CATV:** Se hace este recordatorio para llamar la atención del instalador del sistema CATV sobre el Artículo 820-40 de donde se proporcionan instrucciones para la apropiada conexión a tierra y, en particular, se especifica que la tierra de los cables se conectará al sistema de conexión a tierra del edificio tan cerca del punto de entrada del cable como sea posible.

**Ejemplo de conexión a tierra de la antena según NEC, Código Eléctrico Nacional**

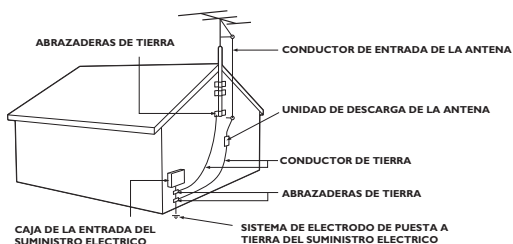

# Contents

---

<b>1</b>	<b>Notice</b>	<b>4</b>
----------	---------------	----------

---

<b>2</b>	<b>Important</b>	<b>6</b>
----------	------------------	----------

---

<b>3</b>	<b>Your TV</b>	<b>9</b>
	TV controls	9
	Remote control	10
	Remote control usage	11

---

<b>4</b>	<b>Use your TV</b>	<b>12</b>
	Switch your TV on	12
	Switch your TV to standby	12
	Switch your TV off	12
	Switch channels	13
	Watch connected devices	13
	Adjust TV volume	14

---

<b>5</b>	<b>Use more of your TV</b>	<b>15</b>
	Access TV menus	15
	Add device to the home menu	15
	Rename devices from the home menu	16
	Remove devices from the home menu	16
	Change picture and sound settings	16
	Create and use list of favorite channels	19
	Display the TV clock	20
	Use timers	21
	Lock unsuitable content	21
	View Scenea	22
	Change language	23
	Play photos, music, and videos on	
	USB storage devices	23
	Update the TV software	25
	Change TV preferences	26
	Start a TV demo	27
	Reset the TV to factory settings	27

---

<b>6</b>	<b>Install channels</b>	<b>28</b>
	Automatically install channels	28
	Rename channels	28
	Hide channels	29
	Unhide channels	29

---

<b>7</b>	<b>Connect devices</b>	<b>30</b>
	Back connectors	30
	Side connector	32
	Connect a computer	32
	Use Philips EasyLink	33

---

<b>8</b>	<b>Product information</b>	<b>35</b>
	Supported display resolutions	35
	Multimedia	35
	Tuner/Reception/Transmission	35
	Remote control	35
	Power	35
	Speakers	35
	Supported TV mounts	36
	Product specification	36

---

<b>9</b>	<b>Troubleshooting</b>	<b>37</b>
	General TV issues	37
	TV channel issues	37
	Picture issues	37
	Sound issues	38
	HDMI connection issues	38
	Computer connection issues	38
	Contact us	39

---

<b>10</b>	<b>Index</b>	<b>40</b>
-----------	--------------	-----------

# Notice

2011 © Koninklijke Philips Electronics N.V. All rights reserved.

Specifications are subject to change without notice. Trademarks are the property of Koninklijke Philips Electronics N.V. or their respective owners. Philips reserves the right to change products at any time without being obliged to adjust earlier supplies accordingly. The material in this manual is believed adequate for the intended use of the system. If the product, or its individual modules or procedures, are used for purposes other than those specified herein, confirmation of their validity and suitability must be obtained. Philips warrants that the material itself does not infringe any United States patents. No further warranty is expressed or implied. Philips cannot be held responsible neither for any errors in the content of this document nor for any problems as a result of the content in this document. Errors reported to Philips will be adapted and published on the Philips support website as soon as possible.

## Pixel characteristics

This LCD product has a high number of color pixels. Although it has effective pixels of 99.999% or more, black dots or bright points of light (red, green or blue) may appear constantly on the screen. This is a structural property of the display (within common industry standards) and is not a malfunction.

## Terms of warranty

No components are user serviceable. Do not open or remove covers to the inside of the product. Repairs may only be done by Philips Service Centres and official repair shops. Failure to do so shall void any warranty, stated or implied.

Any operation expressly prohibited in this manual, any adjustments, or assembly procedures not recommended or authorised in this manual shall void the warranty.

## Compliance with EMF

Koninklijke Philips Electronics N.V. manufactures and sells many products targeted at consumers, which, like any electronic apparatus, in general have the ability to emit and receive electromagnetic signals.

One of Philips' leading Business Principles is to take all necessary health and safety measures for our products, to comply with all applicable legal requirements and to stay well within the Electro Magnetic Field (EMF) standards applicable at the time of producing the products.

Philips is committed to develop, produce and market products that cause no adverse health effects. Philips confirms that if its products are handled properly for their intended use, they are safe to use according to scientific evidence available today.

Philips plays an active role in the development of international EMF and safety standards, enabling Philips to anticipate further developments in standardisation for early integration in its products.

## Open source software

Philips Electronics Singapore Pte Ltd hereby offers to deliver, upon request, a copy of the complete corresponding source code for the copyrighted open source software packages used in this product for which such offer is requested by the respective licenses. This offer is valid up to three years after product purchase to anyone in receipt of this information. To obtain source code, please contact open.source@philips.com. If you prefer not to use email or if you do not receive confirmation receipt within a week after mailing to this email address, please write in English to "Open Source Team, Philips Intellectual Property & Standards, P.O. Box 220, 5600 AE Eindhoven, The Netherlands". If you do not receive timely confirmation of your letter, please email to the email address above. The texts of the licenses and acknowledgements for open source software used in this product are included on a separate leaflet.



## Copyright



® Kensington and Micro Saver are registered US trademarks of ACCO World corporation with issued registrations and pending applications in other countries throughout the world.



HDMI, and HDMI logo, and High-Definition Multimedia Interface are trademarks or registered trademarks of HDMI licensing LLC in the United States and other countries.

All other registered and unregistered trademarks are the property of their respective owners.

# 2 Important

Read and understand all instructions before you use your TV. If damage is caused by failure to follow instructions, the warranty does not apply.

---

## Safety

### Risk of electric shock or fire!

- Never expose the TV to rain or water. Never place liquid containers, such as vases, near the TV. If liquids are spilt on or into the TV, disconnect the TV from the power outlet immediately. Contact Philips Consumer Care to have the TV checked before use.
- Never place the TV, remote control or batteries near naked flames or other heat sources, including direct sunlight. To prevent the spread of fire, keep candles or other flames away from the TV, remote control and batteries at all times.



- Never insert objects into the ventilation slots or other openings on the TV.
- When the TV is swiveled ensure that no strain is exerted on the power cord. Strain on the power cord can loosen connections and cause arcing.
- To disconnect the TV from the mains power, the power plug of the TV must be disconnected. When disconnecting the power, always pull the power plug, never the cord. Ensure that you have full access to the power plug, power cord and outlet socket at all times.

### Risk of short circuit or fire!

- Never expose the remote control or batteries to rain, water or excessive heat.
- Avoid force coming onto power plugs. Loose power plugs can cause arcing or fire.

### Risk of injury or damage to the TV!

- Two people are required to lift and carry a TV that weighs more than 25 kg or 55 lbs.
- When stand mounting the TV, use only the supplied stand. Secure the stand to the TV tightly. Place the TV on a flat, level surface that can support the combined weight of the TV and the stand.
- When wall mounting the TV, use only a wall mount that can support the weight of the TV. Secure the wall mount to a wall that can support the combined weight of the TV and wall mount. Koninklijke Philips Electronics N.V. bears no responsibility for improper wall mounting that results in accident, injury or damage.
- If you need to store the TV, disassemble the stand from the TV. Never lie the TV on its back with the stand installed.
- Before you connect the TV to the power outlet, ensure that the power voltage matches the value printed on the back of the TV. Never connect the TV to the power outlet if the voltage is different.
- Parts of this product can be made of glass. Handle with care to avoid injury and damage.

**Risk of injury to children!**

Follow these precautions to prevent the TV from toppling over and causing injury to children:

- Never place the TV on a surface covered by a cloth or other material that can be pulled away.
- Ensure that no part of the TV hangs over the edge of the surface.
- Never place the TV on tall furniture (such as a bookcase) without anchoring both the furniture and TV to the wall or a suitable support.
- Educate children about the dangers of climbing on furniture to reach the TV.

**Risk of swallowing batteries!**

- The product/remote control may contain a coin type battery, which can be swallowed. Keep the battery out of reach of children at all times!

**Risk of overheating!**

- Never install the TV in a confined space. Always leave a space of at least 4 inches or 10 cm around the TV for ventilation. Ensure curtains or other objects never cover the ventilation slots on the TV.

**Risk of injury, fire or power cord damage!**

- Never place the TV or any objects on the power cord.
- Disconnect the TV from the power outlet and antenna before lightning storms. During lightning storms, never touch any part of the TV, power cord or antenna cable.

**Risk of hearing damage!**

- Avoid using earphones or headphones at high volumes or for prolonged periods of time.

**Low temperatures**

- If the TV is transported in temperatures below 5°C or 41°F, unpack the TV and wait until the TV temperature matches room temperature before connecting the TV to the power outlet.

**Screen care**

- Avoid stationary images as much as possible. Stationary images are images that remain on-screen for extended periods of time. Examples include: on-screen menus, black bars and time displays. If you must use stationary images, reduce screen contrast and brightness to avoid screen damage.
- Unplug the TV before cleaning.
- Clean the TV and frame with a soft, damp cloth. Never use substances such as alcohol, chemicals or household cleaners on the TV.
- Risk of damage to the TV screen! Never touch, push, rub or strike the screen with any object.
- To avoid deformations and color fading, wipe off water drops as soon as possible.

**Temperature and humidity**

In rare occasions, depending on temperature and humidity, minor condensation can occur on the inside of the glass front. To prevent this, do not expose the TV to direct sunlight, heat or extreme humidity. If condensation occurs, it will disappear spontaneously while the TV is playing for a few hours. The condensation moisture will not harm the TV or cause malfunction.

---

## Disposal of your old product and batteries



Your product is designed and manufactured with high quality materials and components, which can be recycled and reused.



When this crossed-out wheeled bin symbol is attached to a product it means that the product is covered by the European Directive 2002/96/EC. Please inform yourself about the local separate collection system for electrical and electronic products.

Please act according to your local rules and do not dispose of your old products with your normal household waste.

Correct disposal of your old product helps to prevent potential negative consequences for the environment and human health.



Your product contains batteries covered by the European Directive 2006/66/EC, which cannot be disposed with normal household waste.

Please inform yourself about the local rules on separate collection of batteries because correct disposal helps to prevent negative consequences for the environmental and human health.

---

## Environmental efforts

Philips continuously focus on lowering the environmental impact of its innovative consumer products. We aim our efforts towards environmental improvements during manufacturing, reduction of harmful substances, energy-efficient use, end-of-life instructions and product recycling.

# 3 Your TV

Congratulations on your purchase, and welcome to Philips! To fully benefit from the support that Philips offers, register your TV at [www.philips.com/welcome](http://www.philips.com/welcome).

## TV controls

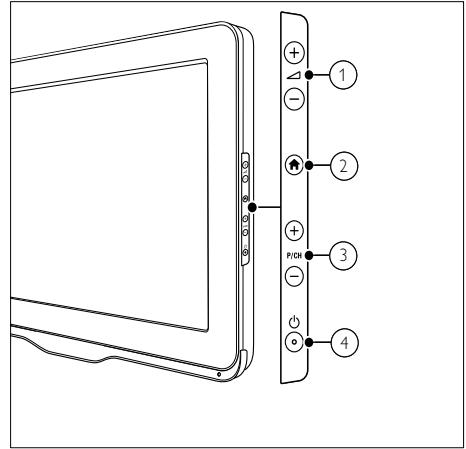

- ① ▲ +/-: Change volume.
- ② 🏠 (Home): Access the home menu.
- ③ P/CH +/-: Change channels.
- ④ ⏻ (Power): Switch the TV on or off.

# Remote control

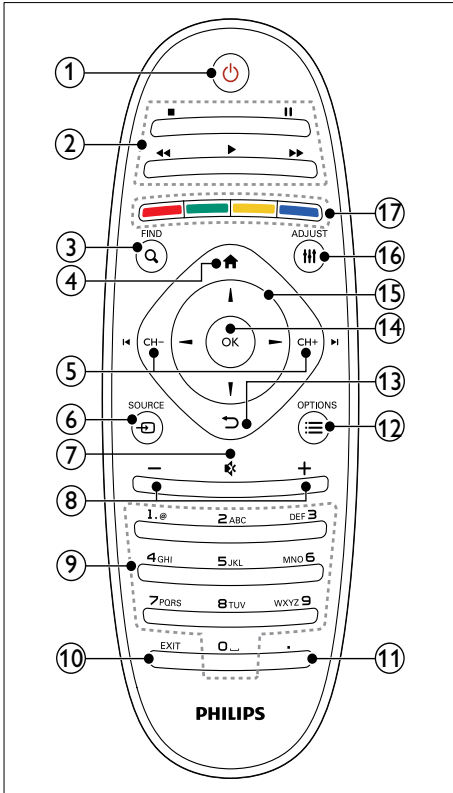

- ① **⏻ (Standby-On)**
  - Switch the TV on or to standby.
- ② **⏮ Play buttons**
  - Control video or music.
- ③ **Q FIND**
  - Access the menu to select a TV channel list.
- ④ **🏠 (Home)**
  - Access the home menu.
- ⑤ **⏪ CH - / CH + ⏩ (Previous/Next)**
  - Switch channels or navigate through menu pages, tracks, albums, or folders.
- ⑥ **📺 SOURCE**
  - Select connected devices.
- ⑦ **🔇**
  - Mute or restore audio.
- ⑧ **+/-**
  - Adjust volume.
- ⑨ **0-9 (Numeric buttons)**
  - Select channels.
- ⑩ **EXIT**
  - Exits a menu.
- ⑪ **. (Dot)**
  - Not in use.
- ⑫ **☰ OPTIONS**
  - Access options for the current activity or selection.
- ⑬ **↶**
  - Return to the previous menu or exit a function.
- ⑭ **OK**
  - Confirm an entry or selection.
- ⑮ **▲ ▼ ◀ ▶ (Navigation buttons)**
  - Navigate through menus and select items.
- ⑯ **⏸ ADJUST**
  - Access the menu to adjust settings.
- ⑰ **Color buttons**
  - Select tasks or options.

## Remote control usage

When you use the remote control, hold it close to the TV and point it at the remote control sensor. Make sure that the line-of-sight between the remote control and TV is not blocked by furniture, walls or other objects.

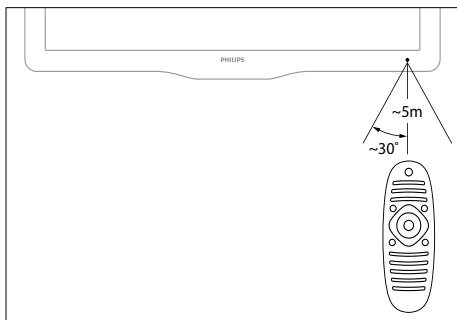

## 4 Use your TV

This section helps you perform basic TV operations.

---

### Switch your TV on

- Press the power switch on the TV.  
↳ There is a short delay before the TV responds.

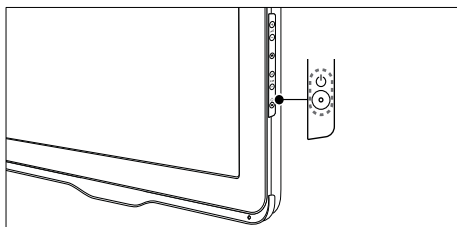

---

### If the TV is in standby

- Press  $\odot$  (Standby-On) on the remote control.

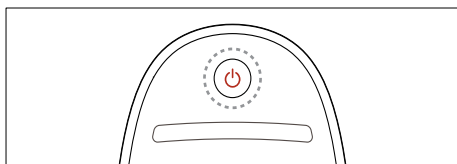

---

### Switch your TV to standby

- Press  $\odot$  (Standby-On) on the remote control again.  
↳ The remote control sensor on the TV switches to red.

---

### Switch your TV off

- Press the power switch on the TV again.  
↳ The remote control sensor on the TV switches off.  
↳ Though the TV consumes very little power when in standby, energy continues to be consumed. When not in use for an extended period of time, disconnect the TV power cable from the power outlet or turn off the power switch.

---

#### Note

- If you cannot locate your remote control and want to switch on the TV from standby, press **P/CH +/-** on the TV.



## Switch channels

- Press **CH+** or **CH-** on the remote control.

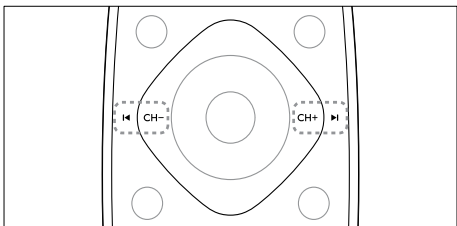

- Press **P/CH +/-** on the TV.

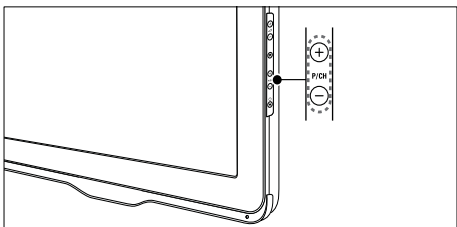

## Other ways to switch channels

- Enter a channel number using the **Numeric buttons**.
- Press **↩ (BACK)** on the remote control to return to the previous channel.

### Note

- When you use a favorite list, you can only select those channels in the list (see 'Create and use list of favorite channels' on page 19).

## View channel grid

You can view an overview of all available channels with the channel grid.

- Press **Q FIND**.  
↳ The channel grid appears.
- To watch a channel, select it, then press **OK**.

## Watch connected devices

### Note

- Before you select a device as a source, switch the device on.

## Select a device from the source list

- Press **⏏ SOURCE**.

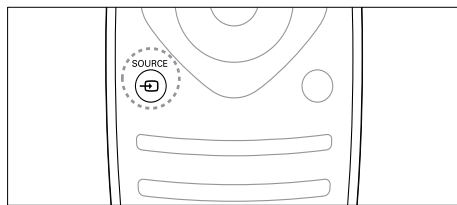

↳ The source list appears.

- Press **▲▼** to select a device.
- Press **OK** to confirm your choice.  
↳ The TV switches to the selected device.

---

## Adjust TV volume

- Press +/- on the remote control.

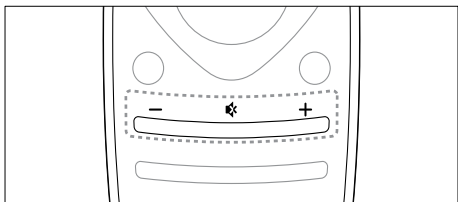

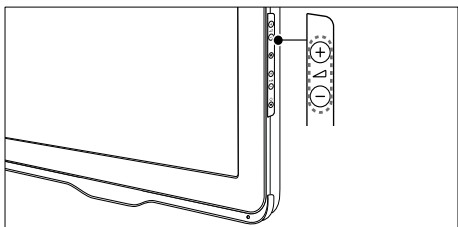

- Press  +/- on the TV.



---

## To mute or unmute sound

- Press  to mute the sound.
- Press  again to restore the sound.

# 5 Use more of your TV

## Access TV menus

Menus help you to install channels, change picture and sound settings and access other features.

1 Press **▲**.

↳ The menu screen appears.

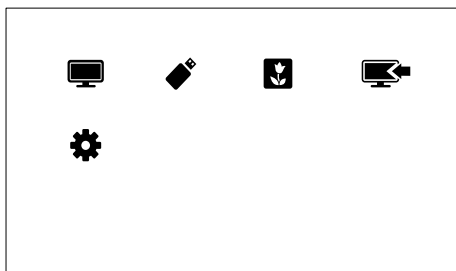

1 Select one of the following, then press **OK**.

- **[Watch TV]**: If a source other than antenna is selected, switch back to the antenna source.
- **[Browse USB]**: If a USB device is connected, access the content browser.
- **[Scenea]**: Switch on Scenea wallpaper.
- **[Add new device]**: Add new devices to the home menu.
- **[Setup]**: Access menus to change picture, sound and other settings.

2 Press **▲** to exit.

## Add device to the home menu

After you connect a device, add it to the home menu.

1 Press **▲**.

2 Select **[Add new device]**.

3 Follow the onscreen instructions to add the device to the home menu.

↳ The device is displayed in the home menu.

4 To watch the device, switch it on, then select it in the home menu.

5 You can also select the device with the source button (see 'Select a device from the source list' on page 13).

---

## Rename devices from the home menu

After you add a new device to the home menu, you can rename it to your preference.

 **Note**

- The device name can be up to 16 characters long.

- 1 Press **▲**.
- 2 Select a device to rename.
- 3 Press **≡ OPTIONS**.  
↳ The options menu appears.
- 4 Select **[Rename device]**, then press **OK**.
- 5 To display the text input box, press **OK**.
- 6 For each character, select a character; then press **OK**.
  - To select uppercase letters, lowercase letters, or symbols: In the row below the space key, select the respective key, then press **OK**.
- 7 When complete, select **[Done]**, then press **OK**.  
↳ The text input box closes.
- 8 In the rename device menu, select **[Done]**, then press **OK**.

---

## Remove devices from the home menu

If a device is no longer connected to the TV, remove it from the home menu.

- 1 Press **▲**.
- 2 Select a device to remove.
- 3 Press **≡ OPTIONS**.
- 4 Select **[Remove device]**, then press **OK**.
- 5 Select **[Remove]**, then press **OK**.  
↳ The selected device is removed from the home menu.

---

## Change picture and sound settings

Change picture and sound settings to suit your preferences. You can apply pre-defined settings or change settings manually.

 **Note**

- While you watch TV or external devices, press **≡ ADJUST**, then select **[Smart picture]** or **[Smart sound]** for quick access to picture and sound settings.

---

## Use settings assistant

Use the settings assistant to guide you through the picture and sound settings.

- 1 Press **▲**.
- 2 Select **[Setup] > [Quick picture and sound settings]**, then press **OK**.
- 3 Select **[Continue]**, then press **OK**.  
↳ The **[Settings assistant]** menu appears.
- 4 Follow the onscreen instructions to choose your preferred picture settings.

## Use smart picture

Use smart picture to apply pre-defined picture settings.

- 1 Press **# ADJUST**.
- 2 Select **[Smart picture]**, then press **OK**.
- 3 Select one of the following settings, then press **OK**.
  - **[Personal]**: Apply your customized picture settings.
  - **[Vivid]**: Rich and dynamic settings, ideal for daytime viewing.
  - **[Football]**: Ideal settings for football matches.
  - **[Cinema]**: Ideal settings for movies.
  - **[Energy saving]**: Settings that conserve the most energy.

## Manually adjust picture settings

- 1 Press **▲**.
  - 2 Select **[Setup] > [TV settings] > [Picture]**, then press **OK**.
  - 3 Select one of the following settings, then press **OK**.
    - **[Smart picture]**: Access predefined smart picture settings.
    - **[Reset]**: Reset to factory default settings.
    - **[Contrast]**: Adjust the intensity of backlight areas, while the video contents are kept unchanged.
    - **[Brightness]**: Adjust the intensity and details of dark areas.
    - **[Color]**: Adjust color saturation.
    - **[Tint]**: Compensate for color variations.
    - **[Sharpness]**: Adjust sharpness in the image.
    - **[Noise reduction]**: Filter and reduce noise in an image.
    - **[Color temp.]**: Adjust the color balance in an image.
    - **[Custom color temp.]**: Customize color temperature setting. (Only available if **[Color temperature] > [Custom]** is selected)
- **[Digital Crystal Clear]**: Fine-tune each pixel to match surrounding pixels. This setting produces a brilliant, high-definition image.
    - **[Advance sharpness]**: Enables superior picture sharpness.
    - **[Dynamic contrast]**: Enhance contrast. **[Medium]** setting is recommended.
    - **[Dynamic backlight]**: Change brightness of the TV backlight to match lighting conditions.
    - **[MPEG artifact reduction]**: Smooth out transitions on digital pictures.
    - **[Color enhancement]**: Make colors more vivid and improves the details in bright colors. You can switch this feature on or off.
    - **[Gamma]**: For selected models. Change the midtone intensity in the picture. Black and white are not affected.
  - **[PC mode]**: If available, when a PC is connected to the TV, adjust the picture.
  - **[Picture format]**: Change the picture format.
  - **[Screen edges]**: Change the viewing area. (when set to maximum, you may see noise or rough edge of an image).
  - **[Picture shift]**: If available, change the picture position for all picture formats except for **[4:3]**, **[Unscaled]** and **[Wide screen]**.

---

## Change picture format

- 1 Press **#** ADJUST.
- 2 Select **[Picture format]**, then press **OK**.
- 3 Select a picture format, then press **OK**.

---

## Summary of picture formats

The following picture settings can be configured.



### Note

- Depending on the format of the picture source, some picture settings are not available.



**[Super zoom]**: (Not for HD and PC mode.) Remove the black bars on the side of 4:3 broadcasts. There is minimal distortion.



**[4:3]**: Show the classic 4:3 format.



**[Unscaled]**: For HD and PC mode only, and in selected models only. Allow maximum sharpness. Some distortion may be present due to the broadcaster's systems. Set your PC resolution to wide screen mode for best results.

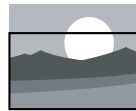

**[Subtitle zoom]**: Display 4:3 pictures over the full area of the screen with subtitles visible. Part of the top of the picture is clipped off.



**[Movie expand 16:9]**: (Not for HD and PC mode.) Scale 4:3 format to 16:9.

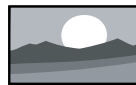

**[Wide screen]**: Scale 4:3 format to 16:9.

---

## Use smart sound

Use smart sound to apply pre-defined sound settings.

- 1 Press **⏏** **ADJUST**.
- 2 Select **[Smart sound]**, then press **OK**.
- 3 Select one of the following settings, then press **OK**.
  - **[Standard]**: Settings that suit most environments and types of audio.
  - **[News]**: Ideal settings for spoken audio, such as news.
  - **[Cinema]**: Ideal settings for movies.
  - **[Sports]**: Ideal settings for sports programs.

## Manually adjust sound settings

- 1 Press **⬆**.
- 2 Select **[Setup] > [TV settings] > [Sound]**, then press **OK**.
  - ↳ The **[Sound]** menu appears.
- 3 Select one of the following settings, then press **OK**.
  - **[Smart sound]**: Access predefined smart sound settings.
  - **[Reset]**: Reset to factory default settings.
  - **[Clear sound]**: Enhance the sound clarity.
  - **[Bass]**: Adjust the bass level.
  - **[Treble]**: Adjust the treble level.
  - **[Surround]**: Switch on spatial sound.
  - **[Auto volume leveling]**: Automatically reduce sudden volume changes, for example, when switching channels.
  - **[Balance]**: Adjust the balance of the right and left speakers.

## Create and use list of favorite channels

You can create a list of your preferred TV channels so that you can find those channels easily.

### View only the list of favorite channels

- 1 While you watch TV, press **Q** **FIND**.
  - ↳ The channel matrix menu is displayed.
- 2 Press **≡** **OPTIONS**.
- 3 Select **[Select list] > [Favorites]**, then press **OK**.
  - ↳ Only channels in the favorites list appear in the channel grid.

#### Note

- The favorites channel grid is empty until you add channels into the favorites list.

### View all channels

You can exit the favorites list, and view all installed channels.

- 1 While you watch TV, press **Q** **FIND**.
  - ↳ The channel matrix menu is displayed.
- 2 Press **≡** **OPTIONS**.
- 3 Select **[Select list] > [All]**, then press **OK**.
  - ↳ All channels are displayed in the channel grid.

#### Note

- All favorite channels are marked by an asterisk, when you view the channel grid.

---

## Manage the favorites list

- 1 While you watch TV, press **Q FIND**.  
↳ The channel matrix menu appears.
- 2 Press **≡ OPTIONS**.
- 3 Select **[Select list] > [All]**, then press **OK**.
- 4 Press **≡ OPTIONS**.
- 5 Select **[Mark as favorite]** or **[Unmark as favorite]**, then press **OK**.  
↳ The channel is added or removed from the favorite list.



### Note

- All favorite channels are marked by an asterisk in the channel grid.

---

## Display the TV clock

You can display a clock on the TV screen.

---

### Set the TV clock manually

- 1 Press **▲**.
- 2 Select **[Setup] > [TV settings] > [Preferences] > [Clock]**.
- 3 Select **[Time]** or **[Date]**, then press **OK**.
- 4 Press the **Navigation buttons** to set the time or date.
- 5 Select **[Done]**, then press **OK**.
- 6 Press **▲** to exit.

---

### Display the TV clock

- 1 While you watch TV, press **≡ OPTIONS**.  
↳ The options menu is displayed.
- 2 Select **[Clock]**.  
↳ The clock is displayed.
- 3 Press **OK**.



### Note

- To disable the clock, repeat the procedure.



## Use timers

You can set timers to switch the TV to standby at a specified time.



Tip

- Set the TV clock before you use timers.

### Automatically switch the TV to standby (sleep timer)

Sleep timer switches the TV to standby after a pre-defined duration.



Tip

- You can switch off your TV earlier or reset the sleep timer during the countdown.

- 1 Press **▲**.
- 2 Select **[Setup] > [TV settings] > [Preferences] > [Sleep timer]**.  
↳ The **[Sleep timer]** menu appears.
- 3 Select a value between zero and 180 minutes.  
↳ If you select zero, the sleep timer switches off.
- 4 Press **OK** to switch on the sleep timer.  
↳ The TV switches to standby after the specified time.

## Lock unsuitable content

You can prevent your children from watching certain programs or channels by locking the TV controls.

### Set or change code

- 1 Press **▲**.
- 2 Select **[Setup] > [Channel settings] > [Child lock]**.
- 3 Select **[Set code]** or **[Change code]**.  
↳ The **[Set code] / [Change code]** menu appears.
- 4 Enter your code using the **Numeric buttons**.  
↳ Follow the on-screen instructions to create or change your PIN code.



Tip

- If you forget your code, enter '8888' to override any existing codes.

---

## Lock or unlock one or more channels

- 1 Press **▲**.
- 2 Select **[Setup] > [Channel settings] > [Child lock] > [Channel lock]**.
- 3 The first time you lock or unlock a channel, you are prompted to enter your PIN code.  
↳ A list of channels is displayed.
- 4 Select the channel that you want to lock or unlock, then press **OK**.  
↳ Locked channels are marked.
- 5 Repeat the process to lock or unlock more channels.
- 6 To activate the locks, switch the TV on and off.  
↳ When you switch channels with **CH -** or **CH +**, the locked channels are skipped.  
↳ When you access the locked channels from the channel grid, you are prompted to enter your PIN code.

---

## View Scenea

You can display a default picture as the wallpaper on your TV. You can also load another picture as the wallpaper. If the sleeptimer is off, the wallpaper is displayed for 240 minutes. Otherwise, it is displayed for the duration of the sleeptimer.

---

## Switch on Scenea

- 1 Press **▲**.
- 2 Select **[Scenea]**, then press **OK**.  
↳ If no picture has been set, the default picture is displayed.  
↳ If a customized Scenea picture is loaded, that picture is displayed (see 'Customize the Scenea picture' on page 22).

---

## Customize the Scenea picture

You can load another picture as the wallpaper.

### Note

- When you load a new Scenea picture, it overrides the current Scenea picture.
- To use another picture as the wallpaper, you need a USB storage device that contains a picture that is less than 1 MB in size.

- 1 Load a picture smaller than 1MB in size into a USB storage device.
- 2 Connect the USB storage device to the TV.
- 3 Press **▲**.
- 4 Select **[Browse USB]**, then press **OK**.
- 5 Select a picture, then press **≡ OPTIONS**.
- 6 Select **[Set as Scenea]**, then press **OK**.
- 7 Press any button to exit Scenea.

## Change language

Depending on your broadcaster, you can change the closed captions, audio language, or both, for a TV channel.

### Change menu language

- 1 Press **▲**.
- 2 Select **[Setup] > [TV settings] > [Preferences] > [Menu language]**, then press **OK**.
- 3 Select a language, then press **OK**.

### Change audio language

You can change the audio language if it is available from your broadcaster.

- 1 While you watch TV, press **≡ OPTIONS**.
- 2 Select **[SAP]**, select the language, then press **OK**.

### Switch on or off closed captions

The caption service displays transmitted CC text. The caption text can be displayed permanently or only when the TV is muted.

#### Note

- Not all TV programs and commercials include closed caption information.
- Refer to the TV program listings in your area for the TV channels and closed caption information. The captioned programs are usually noted in the TV listings with service marks such as 'CC'.

- 1 While you watch TV, press **≡ OPTIONS**.
- 2 Select **[Closed caption]**, then press **OK**.
- 3 Select whether closed captions are displayed, then press **OK**.

### Choose type of closed captions

- 1 Make sure that closed captions are switched on.
- 2 While you watch TV, press **≡ OPTIONS**.
- 3 Select **[Caption service]**, then press **OK**.  
↳ Different types of closed caption text are displayed.
- 4 Select the correct closed captions, then press **OK**.

## Play photos, music, and videos on USB storage devices



#### Caution

- Philips is not responsible if the USB storage device is not supported, nor is it responsible for damage or loss of data from the device.

Connect a USB storage device to play photos, music, or videos stored on it.

- 1 Switch on the TV.
- 2 Connect the USB device to the USB port on the side of your TV.
- 3 Press **▲**.
- 4 Select **[Browse USB]**, then press **OK**.  
↳ The USB browser appears.

### View photos

- 1 In the USB browser, select **[Picture]**, then press **OK**.
- 2 Select a photo or a photo album, then press **OK** to view the photo enlarged to fill the TV screen.
  - To view the next or previous photo, press **◀▶**.
- 3 To return, press **↶**.

---

## View a slide show of your photos

- 1 When a full screen image of a photo is displayed, press **OK**.
  - ↳ A slide show begins from the selected photo.
- Press the following buttons to control play:
  - ▶ to play.
  - || to pause.
  - ◀ or ▶ to play the previous or next photo.
  - ■ to stop.
- To return, press ↶.

---

## Change slide show settings

- 1 While you view a slide show, press **≡ OPTIONS**.
  - ↳ The slide show options menu is displayed.
- 2 Select one of the following, then press **OK**.
  - **[Start/stop slideshow]**: If available, stop music.
  - **[Slideshow transitions]**: Set the transition from one picture to the next.
  - **[Slideshow frequency]**: Select the display time for each photo.
  - **[Repeat] / [Play once]**: Play the repeatedly or once.
  - **[Shuffle on] / [Shuffle off]**: Play the photos in the slideshow at random or sequentially.
  - **[Rotate image]**: Rotate photo.
  - **[Set as Scenea]**: Set the selected picture as the TV wallpaper (see 'View Scenea' on page 22).
  - **[Show info]**: Display the picture name, date, size and next picture in the slide show.
- 3 To return, press ↶.

### Note

- **[Rotate image]**, **[Show info]**, and **[Set as Scenea]** appear only when the slideshow is paused.

---

## Listen to music

- 1 In the USB browser, select **[Music]**, then press **OK**.
- 2 Select a music track or album, then press **OK** to play.
- 3 To control play, press the play buttons:
  - ▶ to play.
  - || to pause.
  - ◀ or ▶ to play the previous or next track.
  - ◀◀ or ▶▶ to search forward or backward.
  - ■ to stop.

---

## Change music settings

- While you play music, press **≡ OPTIONS** to access one of the following settings, then press **OK**.
  - **[Stop playback] / [Start playback]**: Stop or start music play.
  - **[Repeat] / [Play once]**: Play repeatedly or once.
  - **[Shuffle on] / [Shuffle off]**: Play sequence or at random.
  - **[Show info]**: Display the file name.
  - **[Sound]**: Select a smart sound setting.

---

## Watch video

- 1 In the USB browser, select **[Video]**, then press **OK**.
- 2 Press **OK** to play.
- 3 To control play, press the play buttons:
  - ▶ to play.
  - || to pause.
  - ◀ or ▶ to play the previous or next video.
  - ◀◀ or ▶▶ to search forward or backward.
  - ■ to stop.

## Change video settings

- 1 While you play video, press **≡** **OPTIONS** to access one of the following settings, then press **OK**.
  - **[Stop playback] / [Start playback]**: Stop or start video play.
  - **[Repeat] / [Play once]**: Play repeatedly or once.
  - **[Shuffle on] / [Shuffle off]**: Play at random or sequentially.
  - **[Small Screen] / [Full Screen]**: If available, show video in its original (native) size, or expand it to fit the full screen.
  - **[Show info]**: Display the file name.

## View a slide show with music

You can view picture slide show with background music.

- 1 Select an album of songs.
- 2 Press **OK**.
- 3 Press **↵** to return to USB content browser.
- 4 Select an album of pictures.
- 5 Press **OK**.  
↳ The slideshow begins.
- 6 To exit, press **↵**.

## Disconnect a USB storage device



### Caution

- Follow this procedure to avoid damage to your USB storage device.

- 1 Press **↵** to exit the USB browser.
- 2 Wait for five seconds, then disconnect the USB storage device.

## Update the TV software

Philips continuously tries to improve its products and we recommend that you update the TV software when updates are available.

### Update with a USB device

To update with a USB storage device, you need:

- A computer with Internet access
- A USB storage device.

### Step 1: Check the current software version

- 1 Press **▲**.
- 2 Select **[Setup] > [Software settings] > [Current software info]**.  
↳ The current software information is displayed.
- 3 Write down the software version number.
- 4 To return, press **OK**.
- 5 To exit, press **↵**.

---

## Step 2: Download and update the latest software version

- 1 Connect a USB storage device.
- 2 Press **▲**.
- 3 Select **[Setup] > [Update software]**.
- 4 Follow the instructions to load a file onto your USB storage device.
- 5 Connect the USB storage device to your computer; then double-click the file.  
↳ A Web page is launched.
- 6 Follow the instructions in the Web page.
  - If the current software version matches the latest software update file, you do not need to update your TV software.
  - If the current software version is smaller than the latest software update file, download the latest software update file to the root directory of your USB device.
- 7 Disconnect the USB storage device from the computer.

---

## Change TV preferences

Use the preferences menu to customize your TV settings.

- 1 Press **▲**.
- 2 Select **[Setup] > [TV settings] > [Preferences]**.
- 3 Select one of the following, then press **OK**.
  - **[Menu language]**: Select a menu language.
  - **[Sleep timer]**: Switch the TV to standby after a pre-defined duration.
  - **[Location]**: Optimize TV settings for your location - home or shop.
  - **[E-sticker]**: (For shop mode only) Switch the e-sticker on or off.
  - **[Volume bar]**: Display the volume bar when you adjust the volume.
  - **[Auto switch off]**: To conserve energy, set the TV to switch off automatically after a period of inactivity.
  - **[Channel information size]**: Change the type of information that is displayed when you switch channels.
  - **[Key beep]**: Enable audio feedback when you press buttons on the remote control or TV.
  - **[TV position]**: Apply the best settings for your TV based on how it is mounted.
  - **[Auto adjust]**: When a PC is connected, if the picture position is incorrect, re-align the position correctly.
  - **[Clock]**: Display or remove the time from the TV, and sets clock options.
- 4 To exit, press **↶**.

---

## Start a TV demo

You can use demonstrations to better understand the features of your TV. Some demos are not available on certain models. Available demos are displayed in the menu list.

- 1 While you watch TV, press **▲**.
- 2 Select **[Setup] > [Watch demo], OK**.
- 3 Select a demo and press **OK** to view it.
- 4 To exit, press **↶**.

---

## Reset the TV to factory settings

You can restore the default picture and sound settings of your TV. The channel installation settings remain the same.

- 1 Press **▲**.
- 2 Select **[Setup] > [TV settings] > [Factory settings]**, then press **OK**.
- 3 If you are prompted to enter a code, enter the child-lock code (see 'Set or change code' on page 21).  
↳ A confirmation message is displayed.
- 4 Press **OK** to confirm.

## 6 Install channels

The first time you setup your TV, you are prompted to select a menu language and to install TV channels. Afterward, you can re-install channels and customize channels in other ways.

---

### Automatically install channels

You can search and store channels automatically.

- 1 Press **▲**.
- 2 Select **[Setup]** > **[Search for channels]**, then press **OK**.
- 3 Select **[Start]**, then press **OK**.  
↳ The channel installation guide begins.
- 4 Select cable or antenna connection, then press **OK**.  
↳ All available channels are stored.
- 5 To exit, press **OK**.

---

### Rename channels

You can rename channels. The name appears when you select the channel.

- 1 While you watch TV, press **Q FIND**.  
↳ The channel matrix menu is displayed.
- 2 Select the channel to rename.
- 3 Press **☰ OPTIONS**.  
↳ The channel options menu is displayed.
- 4 Select **[Rename channel]**, then press **OK**.
- 5 To display the text input box, press **OK**.
- 6 For each character, select a character, then press **OK**.
  - To select uppercase letters, lowercase letters, or symbols: In the row below the space key, select the respective key, then press **OK**.
- 7 When complete, select **[Done]**, then press **OK**.  
↳ The text input box closes.
- 8 In the rename channel menu, select **[Done]**, then press **OK**.



---

## Hide channels

To prevent unauthorized access to channels, hide them from the channel list.

- 1 While you watch TV, press **Q FIND**.  
↳ The channel matrix menu is displayed.
- 2 Select the channel to hide.
- 3 Press **≡ OPTIONS**.  
↳ The channel options menu is displayed.
- 4 Select **[Hide channel]**, then press **OK**.  
↳ The channel is marked as hidden.

---

## Unhide channels

To prevent unauthorized access to channels, hide them from the channel list.

- 1 While you watch TV, press **Q FIND**.  
↳ The channel matrix menu is displayed.
- 2 Press **≡ OPTIONS**.  
↳ The channel options menu is displayed.
- 3 Select **[Show hidden channels]**, then press **OK**.  
↳ The hidden channels are displayed.
- 4 Select the channel to unhide, then press **≡ OPTIONS**.
- 5 Select **[Unhide channel]**, then press **OK**.  
↳ The channel is no longer marked as hidden.  
↳ You can access the hidden channel.
- 6 To exit, press **↩**.

# 7 Connect devices

This section describes how to connect devices with different connectors. For the location of these connectors on your TV, see the quick start guide. More examples of connections with other devices are provided in the quick start guide.

## Note

- You can use different types of connectors to connect a device to your TV.

## Tip

- After connection, for easy access to your device, add it to the home menu: press **Home**, then select **[Add new device]**.

After you connect a device, add it to the home menu for easy access (see 'Add device to the home menu' on page 15).

## Back connectors

### ① HDMI 1

Digital audio and video input from high-definition digital devices such as Blu-ray players.

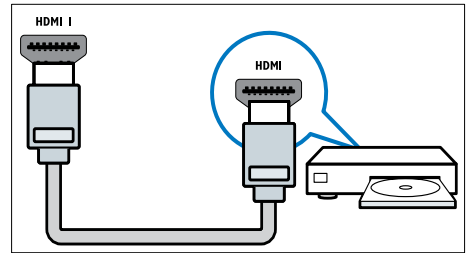

Connections via DVI or VGA require an additional audio cable (see 'Connect a computer' on page 32).

### ② PC IN/AUDIO IN (VGA)

Video/Audio input from a computer.

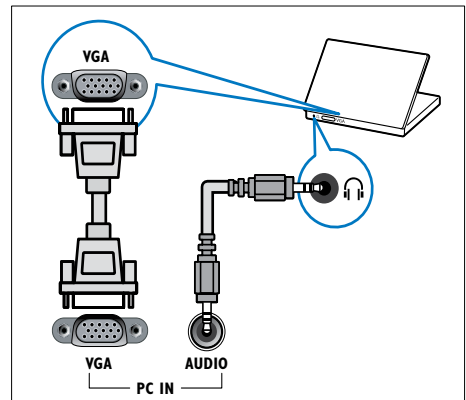

### ③ ANTENNA

Signal input from an antenna or cable.

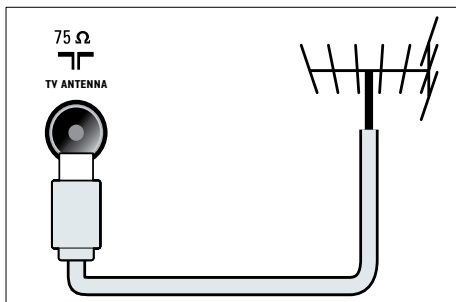

### ④ CVI 1 (Y Pb Pr and AUDIO L/R) / CVI 2 (Y/Video Pb Pr and AUDIO L/R)

Analogue audio and video input from analog or digital devices such as DVD players or game consoles.

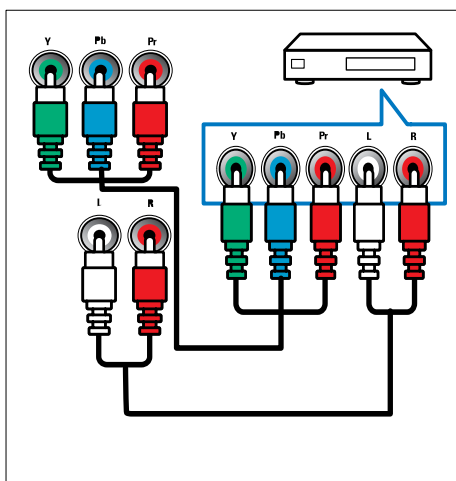

### ⑤ AV out

Digital audio output to home theaters and other digital audio systems.

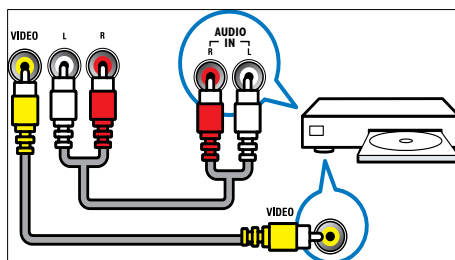

### ⑥ SERV. U

For use by service personnel only.

## Side connector

### ① USB

Data input from USB storage devices.

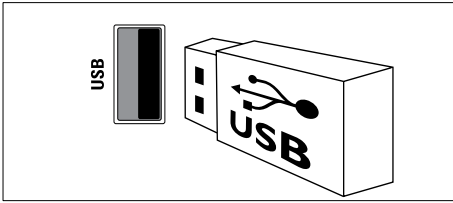

Connections via DVI or VGA require an additional audio cable (see 'Connect a computer' on page 32).

### ② (Headphone)

Stereo audio output to headphones or earphones.

### ③ AV IN (VIDEO and AUDIO L/R)

Analog audio and video input from analog or digital devices such as DVD players, satellite receivers and VCRs.

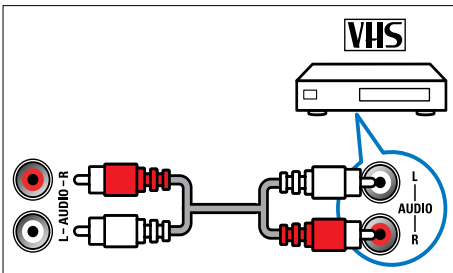
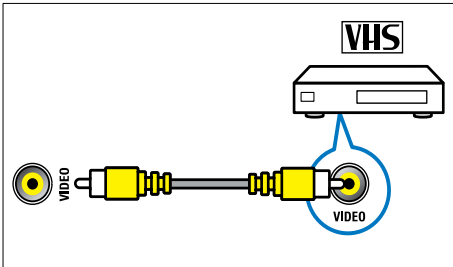

### ④ HDMI

Digital audio and video input from high-definition digital devices such as Blu-ray players.

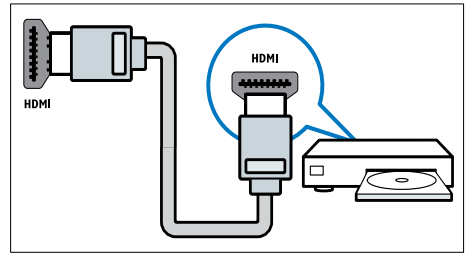

Connections via DVI or VGA require an additional audio cable (see 'Connect a computer' on page 32).

## Connect a computer

### Before you connect a computer to the TV

- Set the screen refresh rate on your computer to 60Hz.
- Select a supported screen resolution on your computer.

Connect a computer with one of the following connectors:

### Note

- Connections via DVI or VGA require an additional audio cable.

- HDMI cable

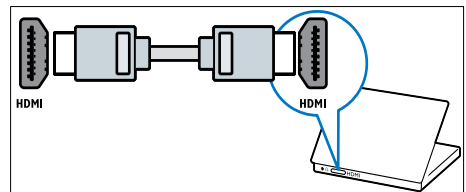

- DVI-HDMI cable

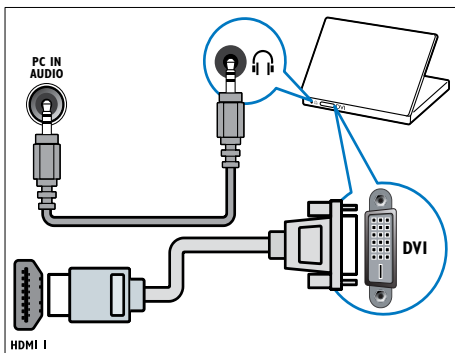

- HDMI cable and HDMI-DVI adaptor

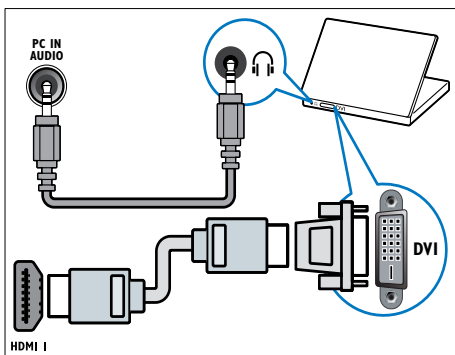

- VGA cable

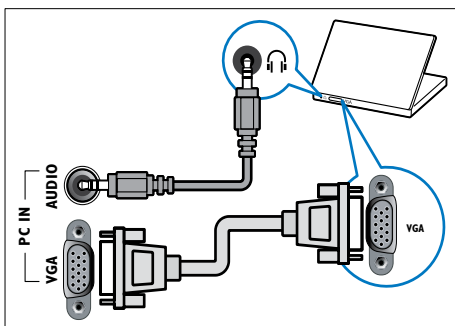

## Use Philips EasyLink

Get the most out of your HDMI-Consumer Electronic Control (CEC) compliant devices with Philips EasyLink enhanced control features. If your HDMI-CEC compliant devices are connected through HDMI, you can control them at the same time with your TV remote control.

To enable Philips EasyLink, you need to:

- Connect at least two HDMI-CEC compliant devices through HDMI
- Configure each HDMI-CEC compliant device properly
- Switch on EasyLink

### Note

- The EasyLink-compliant device must be switched on and selected as the source.
- Philips does not guarantee 100% interoperability with all HDMI CEC devices.

## Switch on or off EasyLink

When you play a HDMI-CEC compliant device, the TV switches on from standby, and switches to the correct source.

### Note

- If you do not intend to use Philips EasyLink, switch it off.

- 1 Press **⬆**.
- 2 Select **[Setup] > [TV settings] > [EasyLink]**.
- 3 Select **[On]** or **[Off]**, then press **OK**.

---

## Use one-touch play

- 1 The first time you use one-touch play:  
Press **▲**, then select **[Setup] > [TV settings] > [EasyLink] > [On]**.
- 2 Press play on your device.  
↳ The TV automatically switches to the correct source.

---

## Use one-touch standby

When you press **⏻** on the TV remote control, the TV and all HDMI-CEC compliant devices switch to standby mode.

- 1 The first time you use one-touch standby:  
Press **▲**, then select **[Setup] > [TV settings] > [EasyLink] > [On]**.
- 2 Press **⏻** (**Standby-On**) on the TV's or device's remote control.  
↳ The TV and all connected HDMI devices switch to standby.

---

## Use a Kensington lock

There is a Kensington security slot at the back of the TV. Prevent theft by looping a Kensington lock between the slot and a permanent object, such as a heavy table.

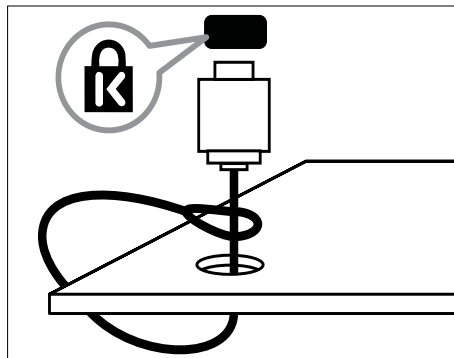

# 8 Product information

Product information is subject to change without notice. For detailed product information, go to [www.philips.com/support](http://www.philips.com/support).

---

## Supported display resolutions

### Computer formats

- Resolution - refresh rate:
  - 640 × 480 - 60Hz
  - 800 × 600 - 60Hz
  - 1024 × 768 - 60Hz
  - 1280 × 1024 - 60 Hz
  - 1360 × 768 - 60Hz

### Video formats

- Resolution - refresh rate:
  - 480i - 60Hz
  - 480p - 60Hz
  - 576i - 50Hz
  - 576p - 50Hz
  - 720p - 50Hz, 60Hz
  - 1080i - 50Hz, 60Hz
  - 1080p - 24Hz, 25Hz, 30Hz, 50Hz, 60Hz.

---

## Multimedia

- Supported storage device: USB (Only FAT or FAT 32 USB storage devices are supported)
- Supported multimedia file formats:
  - Images: JPEG
  - Audio: MP3
  - Video: MPEG 2/MPEG 4, H.264

---

## Tuner/Reception/ Transmission

- Antenna input: 75ohm coaxial (F type)
- TV system: PAL M, PAL N, NTSC M
- Video playback: NTSC, PAL

---

## Remote control

- Type: RC2813801/01
- Batteries: 2 × AAA (LR03 type)

---

## Power

- Mains power: AC 220-240 V (50-60 Hz)
- Standby power: < 0.3W
- Ambient temperature: 5 to 35 degrees Celsius
- For power consumption, see the product specifications at [www.philips.com/support](http://www.philips.com/support).

---

## Speakers

- Total output power: 6 W RMS (10% THD)

---

## Supported TV mounts

To mount the TV, purchase a Philips TV mount or a compatible TV mount.



### Warning

- Follow all instructions provided with the TV mount. Koninklijke Philips Electronics N.V. bears no responsibility for improper TV mounting that results in accident, injury or damage.

Before you mount, perform these steps:

- 1** To prevent damage to cables and connectors, leave a clearance of at least 2.2 inches or 5.5cm from the back of the TV.
- 2** For selected models, remove the wall mount plugs from the back of the TV.
- 3** Make sure that your mounting bolts follow these specifications:

---

TV screen size (inches)	Required pitch (mm)	Required mounting bolts
22	75 x 75	4 x M4 (10mm)

---

---

## Product specification

Design and specifications are subject to change without notice.

### 22PFL3606

- Without TV stand
  - Dimension (WxHxD): 526 x 343.5 x 49.4 (mm)
  - Weight: 3.7 kg
- With TV stand
  - Dimension (WxHxD): 526 x 369.5 x 148.9 (mm)
  - Weight: 3.9 kg



# 9 Troubleshooting

This section describes commonly encountered issues and accompanying solutions.

---

## General TV issues

### The TV does not switch on:

- Disconnect the power cable from the power outlet. Wait for one minute then reconnect it.
- Check that the power cable is securely connected.

### The remote control is not working properly:

- Check that the remote control batteries are correctly inserted according to the +/- orientation.
- Replace the remote control batteries if they are flat or weak.
- Clean the remote control and TV sensor lens.

### The standby light on the TV blinks red:

- Disconnect the power cable from the power outlet. Wait until the TV cools down before reconnecting the power cable. If the blinking reoccurs, contact Philips Consumer Care.

### You forgot the code to unlock the TV lock feature

- Enter '8888'.

### The TV menu is in the wrong language.

- Change the TV menu to your preferred language.

### When turning the TV on/off/to standby, you hear a creaking sound from the TV chassis:

- No action is required. The creaking sound is normal expansion and contraction of the TV as it cools and warms up. This does not impact performance.

### Cannot remove 'e-sticker' banner displayed on the TV.

- To remove the logos and images, set the location of your TV to home.
  1. Press **⬆** (Home).
  2. Select **[Setup] > [Installation] > [Preferences] > [Location]**.
  3. Select **[Home]** and press **OK**.

---

## TV channel issues

### Previously installed channels do not appear in the channel list:

- Check that the correct channel list is selected.

---

## Picture issues

### The TV is on, but there is no picture:

- Check that the antenna is properly connected to the TV.
- Check that the correct device is selected as the TV source.

### There is sound but no picture:

- Check that the picture settings are correctly set.

### There is poor TV reception from an antenna connection:

- Check that the antenna is properly connected to the TV.
- Loud speakers, unearthed audio devices, neon lights, high buildings and other large objects can influence reception quality. If possible, try to improve the reception quality by changing the antenna direction or moving devices away from the TV.
- If reception on only one channel is poor; fine tune this channel.

There is poor picture quality from connected devices:

- Check that the devices are connected properly.
- Check that the picture settings are correctly set.

**The TV did not save your picture settings:**

- Check that the TV location is set to the home setting. This mode offers you the flexibility to change and save settings.

**The picture does not fit the screen; it is too big or too small:**

- Try using a different picture format.

**The picture position is incorrect:**

- Picture signals from some devices may not fit the screen correctly. Check the signal output of the device.

---

## Sound issues

There is picture but no sound from the TV:



### Note

- If no audio signal is detected, the TV automatically switches the audio output off — this does not indicate malfunction.

- Check that all cables are properly connected.
- Check that the volume is not set to 0.
- Check that the sound is not muted.

**There is picture but sound quality is poor:**

- Check that the sound settings are correctly set.

**There is picture but sound comes from one speaker only:**

- Verify that sound balance is set to the center.

---

## HDMI connection issues

**There are problems with HDMI devices:**

- Note that HDCP (High-bandwidth Digital Content Protection) support can delay the time taken for a TV to display content from a HDMI device.
- If the TV does not recognize the HDMI device and no picture is displayed, try switching the source from one device to another and back again.
- If there are intermittent sound disruptions, check that output settings from the HDMI device are correct.
- If you use an HDMI-to-DVI adapter or HDMI to DVI cable, check that an additional audio cable is connected to **AUDIO IN** (mini-jack only).

---

## Computer connection issues

**The computer display on the TV is not stable:**

- Check that your PC uses the supported resolution and refresh rate.
- Set the TV picture format to unscaled.

---

## Contact us

If you cannot resolve your problem, refer to the FAQs for this TV at [www.philips.com/support](http://www.philips.com/support).

If the problem remains unresolved, contact Philips Consumer Care in your country as listed in this user manual.



### Warning

- Do not attempt to repair the TV yourself. This may cause severe injury, irreparable damage to your TV or void your warranty.



### Note

- Make a note of your TV model and serial number before you contact Philips. These numbers are printed on the back of the TV and on the packaging.

# 10 Index

---

<b>A</b>	
age rating	21, 22
analog channels	
closed captions	23
<hr/>	
<b>C</b>	
care	7
channels	
channel list	13
favourites	19
hide or unhide	19
install (automatic)	28
rename	28
switch	13
child lock	21, 22
clock	20
closed captions	23
computer, see PC	32
connect	
connect, PC	32
connect, USB	23
controls	9
<hr/>	
<b>D</b>	
demo	27
devices	
add	15
watch	13
digital channels	
closed captions	23
dimensions	36
display, wallpaper	22
<hr/>	
<b>E</b>	
EasyLink	
enable	33
environmental care	
end of use	8
recycle	8
while you watch TV	8
<hr/>	
<b>F</b>	
factory settings	27
favorites list, add	19
<hr/>	
<b>H</b>	
home menu	15
home mode	26
<hr/>	
<b>I</b>	
install	
install channels	
install channels (automatic)	28
<hr/>	
<b>K</b>	
kensington lock	34
<hr/>	
<b>L</b>	
language	
closed captions	23
menu	23
location, home or shop	26
<hr/>	
<b>M</b>	
multimedia	23
multimedia, play files	23
<hr/>	
<b>P</b>	
PC, display resolutions	35
picture format	18
picture settings	17
position the TV	26
power	35
<hr/>	
<b>R</b>	
recycle	8
reinstall TV	28
rename channels	28

---

<b>S</b>	
Scenea, see screen saver	22
Scenea, switch on	22
screen care	7
screen saver	22
settings	
assistant	16
picture	17
sound	19
shop mode	26
sleeptimer	21
smart picture	17
smart sound	19
software	
USB update	25
version	25
sound settings	19
specifications	35
standby	12
switch	12
switch TV on or off	12

---

<b>T</b>	
troubleshoot	37

---

<b>V</b>	
volume	14

---

<b>W</b>	
wall mount	36

**Artefacto:**

**Modelo:**

**Fabricante/Importador: Philips Argentina S.A.  
y/o Fábrica Austral de Productos Eléctricos S.A.  
Dirección: Vedia 3892 - Buenos Aires**

**Fecha de Venta:**

--

<b>Nro. de serie</b>
----------------------

Firma y sello de la casa vendedora.

PHILIPS ARGENTINA S.A. en adelante denominada “la empresa”, garantiza al comprador de este artefacto por el término de (1) año a partir de la fecha de adquisición, el normal funcionamiento contra cualquier defecto de fabricación y/o vicio de material, y se compromete a reparar el mismo —sin cargo alguno para el adquirente— cuando el mismo fallare en situaciones normales de uso y bajo las condiciones que a continuación se detallan:

1. Este certificado de garantía es válido únicamente en la República Argentina. El certificado debe ser completado por la casa vendedora y ser presentado por el usuario conjuntamente con la factura original de compra.
2. Serán causas de anulación de esta garantía en los casos que corresponda:
  - 2.1. Uso impropio o distinto del uso doméstico.
  - 2.2. Exceso o caídas de tensión eléctrica que impliquen uso en condiciones anormales.
  - 2.3. Instalación y/o uso en condiciones distintas a las marcadas en el “Manual de instalación y uso” que se adjunta a esta garantía.
  - 2.4. Cualquier intervención al artefacto por terceros no autorizados por la empresa.
3. La garantía carecerá de validez si se observare lo siguiente:
  - 3.1. Enmiendas o raspaduras en los datos del certificado de garantía o factura.
  - 3.2. Falta de factura original de compra que detalle tipo de artefacto, modelo, número de serie y fecha que coincida con los del encabezamiento del presente certificado.
4. No están cubiertos por esta garantía los siguientes casos:
  - 4.1. Los daños ocasionados al exterior del gabinete.
  - 4.2. Las roturas, golpes, caídas o rayaduras causadas por traslados.
  - 4.3. Los daños o fallas ocasionados por deficiencias, sobretensiones, descargas o interrupciones del circuito de alimentación eléctrica o rayos, deficiencias en la instalación eléctrica del domicilio del usuario o conexión del artefacto a redes que no sean las especificadas en el Manual de Uso del mismo.
  - 4.4. Las fallas, daños, roturas o desgastes producidos por el maltrato o uso indebido del artefacto y/o causadas por inundaciones, incendios, terremotos, tormentas eléctricas, golpes o accidentes de cualquier naturaleza.
  - 4.5. Las fallas o daños ocasionados en desperfectos en la línea telefónica.
  - 4.6. Las fallas producidas por una mala recepción ocasionada en el uso de una antena deficiente o en señales de transmisión débiles.
5. Las condiciones de instalación y uso del artefacto se encuentran detalladas en el Manual de Uso del mismo.
6. La empresa no asume responsabilidad alguna por los daños personales o a la propiedad al usuario o a terceros que pudieran causar la mala instalación o uso indebido del artefacto, incluyendo en este último caso a la falta de mantenimiento.
7. En caso de falla, el usuario deberá requerir la reparación a la empresa a través del Service Oficial y/o Talleres Autorizados más próximos a su domicilio y cuyo listado se acompaña al presente. La empresa a segura al usuario la reparación y/o reposición de piezas para su correcto funcionamiento en un plazo no mayor a 30 días contados a partir de la fecha de solicitud de reparación, salvo caso fortuito o fuerza mayor.

8. Toda intervención del servicio técnico realizada a pedido del usuario dentro del plazo de garantía, que no fuera originada por falla o defecto alguno cubierto por este certificado, deberá ser abonado por el interesado de acuerdo a la tarifa vigente.
9. El presente certificado anula cualquier otra garantía implícita o explícita, por la cual y expresamente no autorizamos a ninguna otra persona, sociedad o asociación a asumir por nuestra cuenta ninguna responsabilidad con respecto a nuestros productos.
10. En caso de que durante el período de vigencia de esta garantía el artefacto deba ser trasladado a las Delegaciones Oficiales y/o Talleres Autorizados de Service para su reparación, el transporte será realizado por la empresa y serán a su cargo los gastos de flete y seguros y cualquier otro que deba realizarse para su ejecución.

**PHILIPS**

## Red de Talleres Autorizados

### CAPITAL FEDERAL

#### ATTENDANCE S.A.

- Av. Monroe 3351 (1430) Capital Federal
- Tel.: 4545-5574/0704
- Ventas de Repuestos y Accesorios
- Tel.: 4545-0854

#### ELECTARG

- Av. Córdoba 1357 - (1055) Cap. Fed.
- Tel.: 4811-1050
- Ventas de Repuestos y Accesorios

### GRAN BUENOS AIRES

Avellaneda	Torres Juan Carlos	Av. Mitre 2559	4255-5854
Florencio Varela	Torres Juan Carlos	San Martín 2574	4255-5854
Gregorio de Laferrere	Alvarez Corral Manuel	Honorio Luque 6084	4626-1322
Lomas de Zamora	Attendance S.A.	Laprida 485	4292-8900
Merlo	Argentronica S.H.	Pte. Cámpora 2175 (0220) 4837177/4829934	
Morón	Servitronic (Ballesteros)	Ntra. Sra. del Buen Viaje 1222	4627-5656
Olivos	Appliance	Av. Libertador 2684	4794-7700
Quilmes	Torres Juan Carlos	E. Ríos esq. Gran Canaria	4255-5854
San Fernando	Bonelli Miguel Alberto	General Pinto 1252	4744-7240
San Miguel	Paz Marcelo	Belgrano 999	4664-4131
Villa Ballester	Servitronic (Ballesteros)	José Hernández 3101	4767-2515

### CATAMARCA

Catamarca	Omicron	San Martín 225	(03833) 427235
-----------	---------	----------------	----------------

### CHACO

Resistencia	Bonacorsi Mario Evaristo	Vedia 412	(03722) 420504
Resistencia	Freschi Jorge Oscar	Av. Avalos 320	(03722) 426030

### CHUBUT

Comodoro Rivadavia	Monticelli Víctor Carlos	Alem 264	(0297) 4442629
--------------------	--------------------------	----------	----------------

### CORDOBA

Córdoba	Servelco S.R.L.	Pje. E. Marsilla 635 (0351) 4724008/4732024	
Córdoba	Electarg S.R.L.	Avenida Colón 544	(0351) 4255999
Río Cuarto	Maurutto Víctor G.	Bv. Almaguer 487	(0358) 4660204
Río Tercero	Robotti Víctor	Homero Manzi 149	(03571) 423330
San Francisco	Acuña Walter	M. Moreno 360	(03564) 425367
Villa María	Grasso Eduardo	Bv. Alvear 541	(0353) 4521366
Villa María	Rúa Alejandro	Bv. Alvear 221	(0353) 4532951

### CORRIENTES

Corrientes	Alonso Gerardo	Salta 1197	(03783) 466791
Paso de los Libres	Hantouche José	A. Bompland 1090	(03772) 425021
Goya	Quinodoz Carlos M.	José Gomes 1126	(03777) 432402

Caballito	Digi Tronic	Av. San Martín 1762	4583-1501
-----------	-------------	---------------------	-----------

### BUENOS AIRES

Azul	Herlein Raúl Horacio	Av. 25 de Mayo 1227	(02281) 428719
Bahía Blanca	Ortiz Osvaldo Raúl	Soler 535	(0291) 4535329
Junín	Gualberto Marcelo	Alsina 537	(02362) 442754
La Plata	Da Tos Virgilio	Calle 68 N° 1532	(0221) 4516021
La Plata	Lasistec (S.I. La Plata)	Calle 11 N° 1161	(0221) 4217961
Mar de Ajó	Piqué Jorge Roberto	Catamarca 16	(02257) 421750
Mar del Plata	Central Service	Olazábal 2249	(0223) 4721639
Mar del Plata	Iglesias Miguel Angel	Diag. Pueyrredón 3229	(0223) 4945633
Moreno	Argentronica S.H.	Bmé. Mitre 2977 loc.2	(0237) 4639500
Necochea	Leal Carlos	Calle 64 N° 3217	(02262) 430996
Olavarría	Moccorich Juan Antonio	Alsina y Alvaro Barros	(02284) 427974
Pehuajó	Calcagni Carlos Alberto	Zubiría 794	(02396) 472665
Pergamino	Campos Otamendi Alberto	Dr. Alem 758	(02477) 421177
San Nicolás	Presutti José Luis	Bv. Alvarez 148	(03461) 454729
San Pedro	Menisale Alberto	Mitre 1695	(03329) 425523
Tandil	Lazzarini Oscar Rafael	Pellegrini 524	(02293) 442167
Tres Arroyos	Saini Fabián y Sergio	Av. Belgrano 562	(02983) 427369
Zárate	Spinozzi, Julio	Ituzaingó 1030	(03487) 427353
Trenque Lauquen	Labruno	San Martín 426	(02392) 423248

**ENTRE RIOS**

Concordia	Dalzotto Jorge	Humberto Primo 834	(0345) 4219233
Guaaleguaychú	Kroh Adalberto Rubén	Santiago Díaz 22	(03446) 428380

**FORMOSA**

Formosa	Vallejos Rogelio Ramón	Mitre 276	(03717) 435985
---------	------------------------	-----------	----------------

**JUJUJY**

Jujuy	Sandoval Raúl Antonio	Av. P. Marshke 528	(0388) 4256847
-------	-----------------------	--------------------	----------------

**LA PAMPA**

General Pico	Electrónica M.D.	Calle 20 N° 370	(02302) 425047
Santa Rosa	Tecnocyl Electrónica	Av. Roca 179	(02954) 426836

**MENDOZA**

Mendoza	Bonadeo Eduardo A.	Juan B. Justo 595	(0261) 4241111
San Rafael	Di Geronimo José A.	Av. Mitre 575	(02627) 425620 int. 11

**MISIONES**

El Dorado	Pastori Daniel (tele-son)	Polonia 24	(03751) 424014
Monte Carlo	Pastori Daniel	Av. Libertador 1204	(03751) 480311
Posadas	Fouce Juan Carlos	Av. Mitre 1866	(03752) 425921

**NEUQUEN**

Neuquén	Capdevila Ana M. (Tevesur)	Fotheringham 110	(0299) 4430679
---------	----------------------------	------------------	----------------

**SALTA**

Salta	Galland Roque Alberto	Alvarado 1066	(0387) 4317256
-------	-----------------------	---------------	----------------

**SAN JUAN**

San Juan	King Electrónica	Mendoza 802 (Sur)	(0264) 4228918
----------	------------------	-------------------	----------------

**SAN LUIS**

Villa Mercedes	Ciancia Eduardo Rubén	L. Guillet 380	(02657) 423990
San Luis	Rizzotto Carlos Antonio	Maipú 698	(02652) 428747

**SANTA CRUZ**

Río Gallegos	Vivar Héctor	Alberti 267	(02966) 422168
--------------	--------------	-------------	----------------

**SANTA FE**

Rafaela	Forni Horacio María	Sgto. Cabral 104	(03492) 426823
Reconquista	Spontón Alfredo	Habbergger 1516	(03482) 421523
Rosario	Allaria Service S.R.L.	Pte. Roca 371	(0341) 4401598
Rosario	SIP S.R.L.	España 470	(0341) 4252625 ó 4258180
San Jorge	Mandrile Alcides	H. Yrigoyen 1543	(03406) 440513
Santa Fe	Litoral Service S.R.L.	9 de Julio 2785	(0342) 4533563
Venado Tuerto	Degiovanni Adalberto Juan	Av. Hipólito Yrigoyen 1289	(03462) 424613

**SANTIAGO DEL ESTERO**

Santiago del Estero	Barchini Raúl Enrique	Rivadavia 833	(0385) 4213872
---------------------	-----------------------	---------------	----------------

**TIERRA DEL FUEGO**

Río Grande	Mojan Jorge O.	Laserre 670	(02964) 422566
------------	----------------	-------------	----------------

**TUCUMAN**

Tucumán	Albo Roque (Edu-Mag)	M. Avellaneda 129	(0381) 4229078
---------	----------------------	-------------------	----------------

**PARAGUAY**

Asunción	Serviphil	Av. Eusebio Ayala 4181	00595 21 503917
Ciudad del Este	Audio & Video	P. de la Patria c/Av. Caballero	(061) 502962
Concepción	Electrónica Concepción	Presidente Franco 284	(031) 40960
Encarnación	M'S Service Store	Villarrica 472	(071) 202616

**URUGUAY**

Montevideo	C.E.V.	Uruguay 1325	(005982) 901-1212
Montevideo	Makirey S.A.	18 de Julio 2302	(005982) 408-1770

03TA09

*Para realizar consultas sobre este producto, Ud. puede comunicarse con el Centro de Atención al Cliente:*

ARGENTINA  
Tel.: 4544-2047  
Fax: 4545-2928

PARAGUAY  
Tel.: 009-800-54 1 0004  
(Número gratuito)

URUGUAY  
Tel.: 0004-054 176  
(Número gratuito)

**Dirección de mail:  
customerphilips@philips.com.ar**



