

Register your product and get support at
www.philips.com/welcome

43PFD5100/30

EN	User Manual
ZH-HK	用戶手冊

PHILIPS

Contents

1	Notice	2
---	--------	---

2	Important	3
---	-----------	---

3	TV Overview	6
	Control Panel	6
	Remote Control	6
	Use Remote Control	7

4	Using TV	8
	Turn on the TV or switch to standby	8
	Change Channel	8
	To view the connected device(s)	9
	Adjust the TV volume	9

5	Using More Feature of your TV	10
	Accessing TV Menus	10
	Changing the Language	10
	Changing Picture and Sound Settings	10
	Settings	11
	Use timer	12
	Adjusting VGA Setup	13
	Playing media from USB devices	14
	Updating the TV software	15
	Restoring the factory setup	15

6	Installing Channels	16
	Setting up channels automatically	16
	Updating channels	16
	Setting channels manually	16
	Renaming channels	16

7	Connecting Devices	18
	Bottom Connectors	18
	Side Connectors	19
	Connecting a Computer	20
	Using Philips EasyLink	21

	Using a Kensington Security Lock	21
--	----------------------------------	----

8	Product Information	22
	Supported Input Signal Formats	22
	Multimedia	22
	Tuner / Reception / Transmission	22
	Remote Control	22
	Power	22
	Supported TV Mounts	22

9	Trouble Shooting	23
	General TV Issues	23
	TV Channel Issues	23
	Picture Issues	23
	Sound Issues	24
	HDMI Connection Issues	24
	Computer Connection Issues	24
	Contact Us	24

10	Warranty	26
----	----------	----

1 Notice

2015 © TPVision Europe B.V. All Right Is Reserved. Specifications are subject to change without notice. Trademarks are the property of Koninklijke Philips N.V. or their respective owners. TPVision Europe B.V. reserves the right to change products at any time without being obliged to adjust earlier supplies accordingly. The material in this manual is believed adequate for the intended use of the system. If the product, or its individual modules or procedures, are used for purposes other than those specified herein, confirmation of their validity and suitability must be obtained. TP Vision Europe B.V. warrants that the material itself does not infringe any United States patents. No further warranty is expressed or implied. TPVision Europe B.V. will not be responsible for any errors in the content of this document, nor any issues caused by the content of this document. Errors reported to Philips will be adapted and published on the Philips support website as soon as possible.

Pixel Characteristics

This LCD product has a high number of colour pixels. Although it has effective pixels of 99.999% or more, black dots or bright points of light (red, green or blue) may still appear constantly on the screen. This is a structural property of the display (within common industry standards) and is not a malfunction.

Warranty

You cannot replace any components. DO NOT open or remove the rear chassis of the TV to expose the product's interior. Always contact Philips Service Centre or its authorised repair shops for service or repairs. Otherwise, all express or implied warranties will become void. Any operation expressly prohibited in this manual, or any adjustment or assembly procedure not recommended or authorised in this manual, is not covered under warranty.

Copyright

All other registered and unregistered trademarks are the property of their respective owners.

® Kensington and Micro Saver are registered US trademarks of ACCO World Corporation with issued registrations and pending applications in other countries throughout the world.

© The FreeType Project (www.freetype.org) owns the copyright to the software.



Manufactured under license from Dolby Laboratories. Dolby and the double-D symbol are trademarks of Dolby Laboratories.



HDMI, the HDMI logo and High-Definition Multimedia Interface are trademarks or registered trademarks of HDMI Licensing LLC.

Philips and the Philips Shield Emblem are registered trademarks of Koninklijke Philips N.V. and are used under licence from Koninklijke Philips N.V.

2 Important

Read and understand all instructions before you use your TV. If damage is caused by failure to follow instructions, the warranty does not apply.

Safety

Risk of electric shock or fire!!

- Never expose the TV to rain or water. Never place liquid containers, such as vases, near the TV. If liquids are spilt on or into the TV, disconnect the TV from the power outlet immediately. Contact Philips Consumer Care to have the TV checked before use.
- Never place the TV, remote control or batteries near naked flames or other heat sources, including direct sunlight. To prevent the spread of fire, keep candles or other flames away from the TV, remote control and batteries at all times.



- Never insert objects into the ventilation slots or other openings on the TV.
- When the TV is swivelled ensure that no strain is exerted on the power cord. Strain on the power cord can loosen connections and cause arcing.

Risk of short circuit or fire!

- Never expose the remote control or batteries to rain, water or excessive heat.
- Avoid force coming onto power plugs. Loose power plugs can cause arcing or fire.

Risk of injury or damage to the TV!

- Two people are required to lift and carry a TV that weighs more than 25 kg or 55 lbs.
- When stand mounting the TV, use only the supplied stand. Secure the stand to the TV tightly. Place the TV on a flat, level surface that can support the combined weight of the TV and the stand.

- When wall mounting the TV, use only a wall mount that can support the weight of the TV. Secure the wall mount to a wall that can support the combined weight of the TV and wall mount. TPVision Europe B.V. bears no responsibility for improper wall mounting that result in accident, injury or damage.
- Parts of this product may be made of glass. Handle with care to avoid injury and damage.

Risk of injury to children!

Follow these precautions to prevent the TV from toppling over and causing injury to children:

- Never place the TV on a surface covered by a cloth or other material that can be pulled away.
- Ensure that no part of the TV hangs over the edge of the surface.
- Never place the TV on tall furniture (such as a bookcase) without anchoring both the furniture and TV to the wall or a suitable support.
- Educate children about the dangers of climbing on furniture to reach the TV.

Risk of swallowing batteries!

- The product/remote control may contain a coin-type battery, which can be swallowed. Keep the battery out of reach of children at all times!

Beware of overheating!

- Never install the TV in a confined space. Always leave a space of at least 4 inches or 10 cm around the TV for ventilation. Ensure curtains or other objects never cover the ventilation slots on the TV.

Risk of damage to the TV!

- Before you connect the TV to the power outlet, ensure that the power voltage matches the value printed on the back of the TV. Never connect the TV to the power outlet if the voltage is different.
- If you need to store the TV, disassemble the stand from the TV. Never lay the TV on its back with the stand installed.

Risk of injury, fire or power cord damage!

- Never place the TV or any objects on the power cord.
- To easily disconnect the TV power cord from the power outlet, ensure that you have full access to the power cord at all times.
- When you disconnect the power cord, always pull the plug, never the cable.
- Disconnect the TV from the power outlet and antenna before lightning storms. During lightning storms, never touch any part of the TV, power cord or antenna cable.

Risk of hearing damage!

- Avoid using earphones or headphones at high volumes or for prolonged periods of time.

Low temperatures

- If the TV is transported in temperatures below 5°C or 41°F, unpack the TV and wait until the TV temperature matches room temperature before connecting the TV to the power outlet.

Screen Care

- Avoid stationary images as much as possible. Stationary images are images that remain on-screen for extended periods of time. Examples include: on-screen menus, black bars and time displays. If you must use stationary images, reduce screen contrast and brightness to avoid screen damage.
- Unplug the TV before cleaning.
- Clean the TV and frame with a soft, damp cloth. Never use substances such as alcohol, chemicals or household cleaners on the TV.
- Risk of damage to the TV screen! Never touch, push, rub or strike the screen with any object.
- To avoid deformations and colour fading, wipe off water drops as soon as possible.



Caution

Stationary images may result in permanent damage to the TV screen.

- Do not display stationary images on the LCD screen for more than two hours as this may result in ghost images. To prevent this, reduce screen brightness and contrast.
- Viewing programs in the 4:3 format for extended periods of time may leave different traces on the left and right edges of the screen as well as along the borders of the image. Avoid using this mode for extended periods of time.
- Displaying stationary images from video games or computers for an extended period of time may result in partial after-images and the appearance of ghost images caused by screen burn. Reduce screen brightness and contrast accordingly when using the TV in this way.

Ghost images, partial after-images, and other traces that appear on the TV screen as a result of the above are not covered by the warranty.

Disposal of Your Old Product and Batteries



Your product is designed and manufactured with premium materials and elements, which can be recycled and reused.



If the product comes with crossed recycle bin label, it means the European Directive 2002/96/EC is applicable to the product. Please check the local electronics and electronic products separate collection system for information.

Please dispose according to the local regulations; please do not dispose the products with other household waste.

Proper disposal of the product can help reduce the negative impacts on the environment and mankind health.



Your product contains the batteries that are compliance to Eurioean Directive 2006/66/EC, and may not be disposed together with other household waste.

Please note the local regulations related to batteries separate collection as proper disposal of the product can help reduce the negative impacts on the environment and mankind health.

3 TV Overview

congratulations for purchasing and using Philips product! In order to enjoy all the supports provided by Philips, please register your TV at www.philips.com/welcome

Control Panel

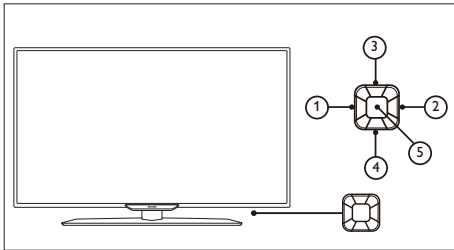

- ① Volume -: Without the key menu, the volume-down function is available.
- ② Volume +: Without the key menu, the volume-up function is available.
- ③ Channel +: When there is no keyboard menu, switch to the next channel function; when the keyboard menu appears, move up and down the appropriate options.
- ④ Channel -: When there is no keyboard menu, switch to the prior channel function; when the keyboard menu appears, move up and down the appropriate options.
- ⑤ Signal source/OK: In standby, the signal source/OK key is used as a power key. Press this key to boot. After booting, the signal source/OK key is used to open the keyboard menu functions. When the keyboard menu function is opened, the menu key is used as confirmation key.
Note: In USB mode, the signal source/OK key has no function

Remote Control

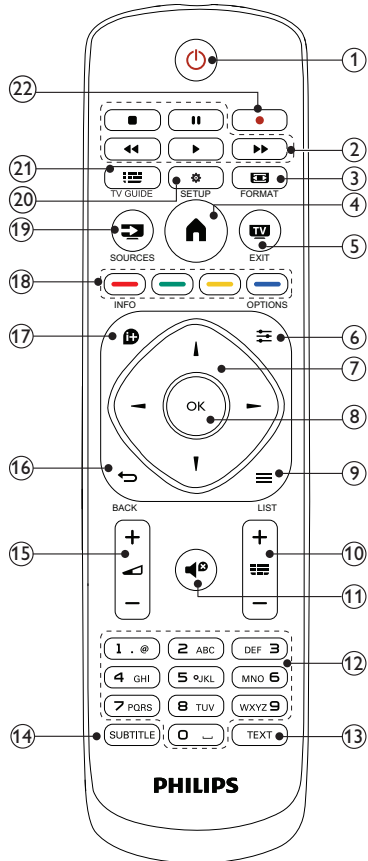

- ① **Standby-Power On**
 - When the TV is on, switch it to standby.
 - Power on when the TV is in standby mode.
- ② **Play Button**
Control video, music or text.
- ③ **FORMAT**
Changes the Picture Format.
- ④ **(Home)**
Access or exit from the main menu and return to the previous menu.
- ⑤ **TV EXIT**
Switches to TV.

- ⑥ **☰ OPTIONS**
Access options for channels in the TV mode.
- ⑦ **▲▼◀▶ (Navigation Button)**
Navigation between menus and select items.
- ⑧ **OK**
Confrim the entry or selection.
- ⑨ **☰ LIST**
Access or exit from the TV channel list.
- ⑩ **CH + / - (CHANNEL+/-)**
Changes channels, scrolls up/down through the options in USB mode.
- ⑪ **🔊 (MUTE)**
Mute or restore audio.
- ⑫ **0-9 (Numeric buttons)**
Select channel.
- ⑬ **TEXT**
Enable or disable teletext.
- ⑭ **SUBTITLE**
Select the subtitles or audio track.
- ⑮ **+/- (VOLUME)**
Adjust volume.
- ⑯ **↶ (BACK)**
Return to the previous menu or exit from a certain function , and switch to the previous channel or signal source.
- ⑰ **i+ INFO**
Display information about current activity.
- ⑱ **Color buttons**
To choose the tasks or options.
- ⑲ **📺 SOURCES**
Select connected devices.
- ⑳ **⚙️ SETUP**
Accesses TV setup menu.
- ㉑ **📺 TV GUIDE**
Accesses or exits the TV guide.
- ㉒ **● Red**
The red key has no function.

Use Remote Control

When using the remote control, press and hold the controller at a close distance to the TV and point it toward the remote control sensor. Ensure there are no furnitures, walls or other objects in between the controller and the TV.

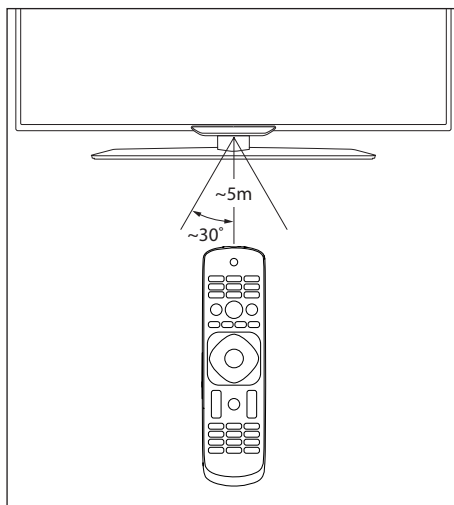

4 Using TV

This section introduces the basic operations of the TV.

Turn on the TV or switch to standby

Use power switch

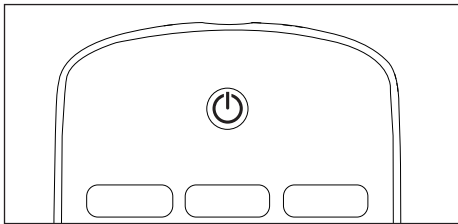
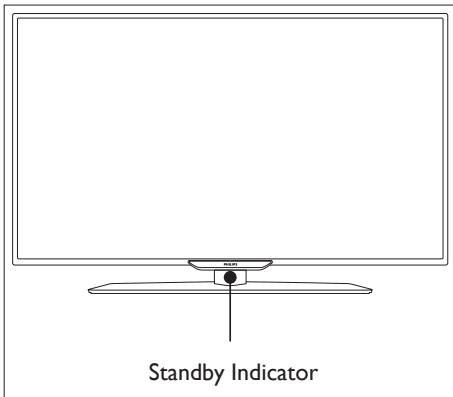

To switch on

- Please plug the power cable to the power socket.
 - ↳ If the standby indicator is red, press the **⏻ (Standby-ON)** on the remote control.

To switch to standby

- Press the **⏻ (ON-Standby)** on the remote control.
 - ↳ The standby indicator turns red.



Tip

- Although the power consumption during standby is low, it still consumes power. Please unplug the power cord if the product is not used for a long time.

Change Channel

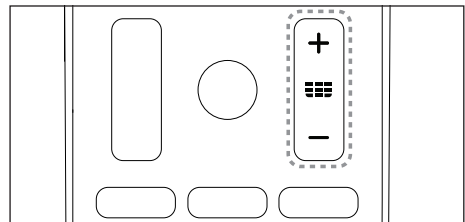
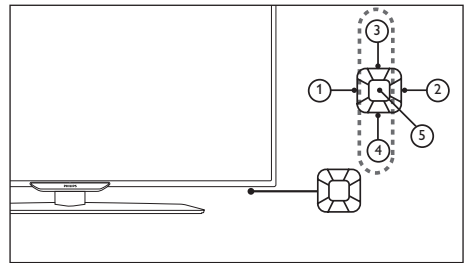

Change channel without using the channel list

- Press CH +/- on the remote control or the lower right part of the TV.
- Use the number buttons on the remote control to enter the channel number.
- Press the **↶** on the remote controller to switch back to the previous channel.

Change channels with the channel list

You can use the channel list to view all the received channels.

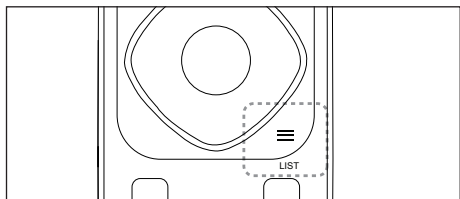

- 1 Press **≡ LIST**.
↳ To display the channel grid.
- 2 Press **▲▼** to select a channel and browse the channel list.
- 3 Press **OK** to view the selected channel.
- 4 Press **↶** to switch to and resume the last watched channel.

To view the connected device(s)

≡ Note

- Before selecting the external signal source, please turn on the external device.

To use the signal source button

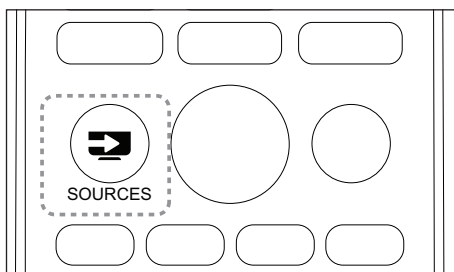

- 1 Press **➡ SOURCES**.
↳ The signal source list appears.
- 2 Press **◀▶** to select a device.

- 3 Press **OK** to select.
↳ The TV switches to the selected device.

Adjust the TV volume

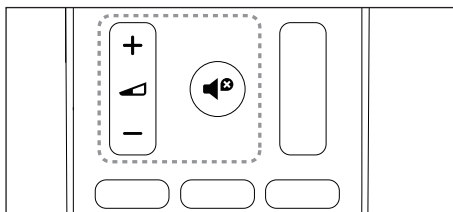
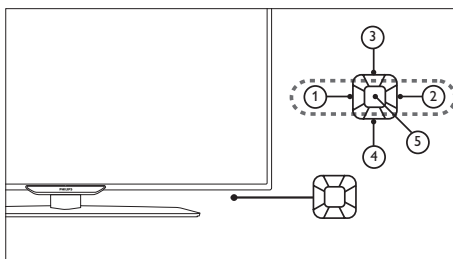

Volume up or down

- Press **VOL +/-** at the lower right part of the TV or the Volume Control +/- on the remote control.

Mute or unmute

- Press **🔇** (Mute).
- Press **🔊** again to unmute.

5 Using More Feature of your TV

Accessing TV Menus

Menus help you to install channels, change picture and sound settings and access other features.

- 1 Press **Home** (Home).
↳ Display menu screen.

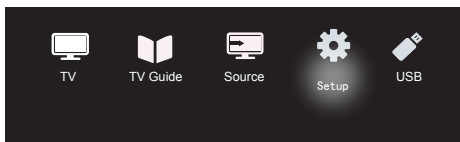

- 2 Select **[Setup]**.
- 3 Press **Up** **Down** **Left** **Right** to choose from the following options:
 - **[Picture]** / **[Sound]** / **[TV]** (available only in TV mode) / **[Settings]** / **[Parental]** / **[VGA Setting]** (available only in PC mode) / **[EasyLink]**.
- 4 Press **OK** to select.
- 5 Press **Home** (Home) to exit or return to previous menu.

Changing the Language

You can choose to change the language of the menu.

Changing the menu language

- 1 Press **Home** (Home) then select **Setup** to enter the setup menu and select **[Menu Language]**.
- 2 Press **Right** to enter **[Menu Language]** to select your desired language, and press **OK**.

Changing Picture and Sound Settings

Change picture and sound settings to suit your preferences. You can apply pre-defined settings or change settings manually.

Adjusting the picture setup

- 1 Press **Home** (Home), then select **Setup** to enter the setup menu and select **[Picture]**.
↳ Displays the **[Picture]** menu.
- 2 Press **Up** **Down** **Left** **Right**, selecting/adjusting setup:
 - **[Smart picture]**:
 - **[Standard]**: Normal picture setup. Recommended for home entertainment use.
 - **[Eco]**: Decreases the intensity of the backlight to reduce power consumption.
 - **[Vivid]**: Increases the contrast and sharpness of the picture.
 - **[Movie]**: Applies setup for watching movies, which works best in a theater environment.
 - **[Personal]**: Users can define custom setup here.
 - **[Brightness]**: Adjusts the intensity and detail of dark areas (adjustments made can only be saved in personal setup).
 - **[Video contrast]**: Adjusts the intensity and detail of bright areas, with dark areas remaining unchanged (adjustments made can only be saved in personal setup).
 - **[Color]**: Adjusts the color saturation (adjustments made can only be saved in personal setup).
 - **[Tint]**: Adjusts the level of green (this option only appears when using the NTSC standard).
 - **[Sharpness]**: Adjusts the sharpness of the image (adjustments made can only be saved in personal setup).
 - **[Color Temperature]**:
 - **[Cool]**: Bluish white tint.

- **[Normal]**: White tint. Users can personalize the white tint in PC mode.
- **[Warm]**: Reddish white tint.
- **[Advanced control]**:
 - **[Noise Reduction]**: Filters and eliminates signal noise within the image.
 - **[Backlight]**: Adjusts the screen brightness (when the backlight brightness is set to a low value, a momentary white flicker may be visible when turning on the unit. This is normal. When **[Dynamic Backlight]** is turned on, this function will be hidden).
 - **[Dynamic Contrast]**: Sets the contrast to maximum. (There are no advanced contrast functions in PC mode.)
 - **[Dynamic Backlight]**: The contrast level will change with the brightness of the image.

Note

- The options may vary for different signal sources.

Adjusting the sound setup

- 1 Press **⏠** (Home), then select Setup to enter the setup menu and select **[Sound]**.
↳ Displays **[Sound]** menu.
- 2 Press **▲▼◀▶** Select and adjust the setup:
 - **[Smart Sound]**:
 - **[Standard]**: Gives balanced, outstanding sound performance in the treble, mid and bass ranges.
 - **[Music]**: Enhances treble and bass, delivering bright, clear and pure sound quality when listening to piano or orchestral instrument performances.
 - **[Movie]**: Enhance sound quality of movies to enjoy a cinema-like effects at home.
 - **[Speech]**: Enhances the performance of sound ranges

involved in the voice spectrum. Suitable for watching news or arts programs.

- **[Flat]**: Enhance the smoothness of audio output for softer sound.
- **[Personal]**: Provides user customization functions in order to optimize all sound effect parameters and achieve the best experience.
- **[Balance]**: Adjusts the balance of the left and right speakers.
- **[Bass]**: Adjusts the bass level (adjustments made can only be saved in personal setup).
- **[Treble]**: Adjusts the treble level (adjustments made can only be saved in personal setup).
- **[Virtual surround]**: Turns virtual surround sound on: Turn on or off.
- **[AVL]**: Turns automatic volume adjustment on.
- **[SPDIF Mode]**: Selects the SPDIF output mode.

Settings

- 1 Press **⏠** (Home), then select Setup to enter the setup menu and select **[Settings]**.
↳ Displays **[Settings]** menu.
- 2 Press **▲▼◀▶** Select and adjust the setup:
 - **[Menu language]**: Changes the TV's language setup.
 - **[Picture Format]**: The majority of signals use 16:9, 4:3, Zoom 1 and Zoom 2 formats; HDMI signal sources use 16:9, 4:3, Point to Point, zoom 1 and zoom 2 formats; VGA signal sources on PCs use 16:9, 4:3 and Point to Point formats.
 - **[Menu Timeout]**: Sets the duration for which the menu is displayed.
 - **[Menu Transparency]**: Sets the level of transparency for the menu.
 - **[Blue Screen]**: Sets the screen color for when the TV is not receiving

a signal (when the TV signal is not functioning).

- **[Auto Sleep]**: Sets the duration the TV may be idle before it automatically switches off.
- **[Sleep Timer]**: (Sleep Timer): Sets the duration before the TV automatically enters standby mode. Options: Off/10/20/30/60/90/180 minutes.
- **[Power On Status]**: Sets the TV's status when it is connected to an AC power supply.
- **[Time Setup]**: Sets the system time.
- **[Color System]**: Sets the AV color system. (Only displayed in AV mode)
- **[HDMI]**: Sets the HDMI mode. (Only displayed in 480p/576p/720p/1080p HDMI modes.)
- **[Reset]**: Restores the default setup. (Excluding password setup and channel information)
- **[Reinstall TV]**: Restore default setup and go back to installation wizard menu.

Changes the Picture Format

- 1 Press **⬆** (Home), then select Setup to enter the setup menu and select **[Settings]**.
- 2 Press **▲▼◀▶** to select **[Picture Format]**.
- 3 Select a picture format.
- 4 Press OK to confirm.

Summary of Picture Formats

The following picture settings can be configured.

Note

- Depending on the format of the picture source, some picture settings are not available.



[16:9]: Change the normal ratio to widescreen format.



[4:3]: The normal format.



[Zoom1]: Horizontal scaling of the widescreen picture format. When this format is used, the two edges of the picture frame will be partly cut off.



[Zoom2]: Set the normal ratio to widescreen format. (Only 16:9, 4:3, and Point to Point are available in PC mode)



[Point to Point]: Used for HDMI connections on PCs. Will display the PC's full screen in order to achieve the best display effect.

Use timer

You can set the timer to switch the TV to standby mode at a set time.

Tip

- Before using the timer, please set the sleep timer.

Setting the sleep timer

Tip

- You can turn the TV off earlier, or reset the sleep timer before the TV switches off.

- 1 Press **⬆** (Home), then select Setup to enter the setup menu and select **[Settings]**.
- 2 Press **▲▼◀▶** to select **[Sleep Timer]**.
- 3 Press **▲▼**, you can select a time for the sleep timer to turn the TV off.

- ↳ The longest time that can be set for the sleep timer is 180 minutes.

TV lock

By locking the TV remote control, you can prohibit children from watching specific programs or channels.

Setting or changing your password

- 1 Press **⏠** (Home), then select Setup to enter the setup menu and select **[Parental]**.
- 2 Use the number buttons on the remote control to enter a password.
- 3 Select **[Change Password]** and follow the instructions on screen.

Locking channels

- 1 Press **⏠** (Home), then select Setup to enter the setup menu and select **[Parental]**.
 - 2 Enter the password and select **[Channel Lock]**.
 - 3 Choose a channel. Press OK to lock or unlock the channel.
 - 4 Repeat this step to lock or unlock multiple channels.
- **[Channel Lock]:** When channels are locked:
 - You need to enter the four digit password to enter the channel blocking menu.
 - You need to enter the four digit password to watch locked channels.
 - You need to enter the four digit password to enter the parental menu.
 - **[Clear All]:** This function will clear all the locked channels and signal sources that you have previously saved.
 - The default password is "0000". Users may change or set the password themselves.

Note

- If you visit a locked channel, you will be prompted to enter the password.

Adjusting VGA Setup

- 1 Press **⏠** (Home), then select Setup to enter the setup menu and select **[VGA setting]**.
 - ↳ The **[VGA setting]** menu will be displayed.
- 2 Press **▲ ▼ ◀ ▶** Select and adjust the setup:
 - **[Auto adjust]:** Automatically adjusts the TV to synchronize its resolution with that of the PC, so that programs are displayed in full screen.
 - **[H.Position]:** Adjusts the horizontal position.
 - **[V.Position]:** Adjusts the vertical position.
 - **[Phase]:** Adjusts the phase frequency of the VGA signal.
 - **[Clock]:** Adjusts the clock frequency of the VGA signal.

Tip

- The VGA menu is only visible when connected to a PC.

Playing media from USB devices

If you have photos, music or video files stored on a USB storage device, you can play the files on your TV.

- Supported storage device: USB (only FAT or FAT 32 USB storage devices are supported.)
- Compatible multimedia file formats:
 - Images: JPEG
 - Audio: MP3
 - Video: MPEG 2/MPEG 4, H.264
 - Text files: TXT



Caution

- TPVision is not responsible if the USB storage device is not supported nor is it responsible for damage or loss of data from the device.

Viewing photos and playing audio, video, and textfiles

- 1 Turn on the TV.
- 2 Connect the USB storage device to the USB port on the side of the TV.
- 3 Press (Home).
- 4 Select [USB] and press OK.
 - ↳ The USB browser will open.

Viewing photos

- 1 In the USB browser, select [**Photo**] and press OK.
- 2 Select a photo or folder, then press OK. The photo will be enlarged to fill the screen.
 - Press CH- or CH+ to see the previous or next photo.

Starting slide shows

- 1 Select a photo or folder, then press OK. The photo will be enlarged to fill the screen.
 - ↳ Displays the option list of the slides; The slide show starts playing from the selected photo.

- 2 Press the following buttons to control photo playback:
 - or : Play or pause
 - CH- or CH+: See the last photo or the next photo.

Changing slide show playback setup

When you want to start playing a slide show, press (Home) and select one of the following options, then press OK.

- [**Repeat**]: Set the playback mode.
- [**Shuffle**]: Play the slide show in order or at random.
- [**Speed**]: Sets the slide duration.
- [**Slide Transitions**]: Set special effects to show during transitions between photos.

Listening to music

- 1 In the USB browser, select [**Music**] and press OK.
- 2 Select a song or album, then press OK to start playing.

Changing the music setup

- or : Play or Pause.
- or : Previous or Next.
- : Loop once.
- (Blue): Shuffle.
- 1: Repeated playing of a single song
- (Blue): Repeat.

Watching video

- 1 In the USB browser, select [**Movie**], then press OK.
- 2 Press OK to play the video.
- 3 Use the following buttons to control the movie:
 - or : Play or Pause.
 - or : Search forward or backward.

Viewing documents

- 1 In the USB browser, select **[Text]**, then press OK.
- 2 Press OK to read the text file.
- 3 Use the following buttons to control text file playback:
 - **▶** or **||**: Play or Pause.
 - **◀◀** or **▶▶**: Search forward or backward.

- 3 Select **[Confirm]** and press OK. If you want to cancel, please select **[Cancel]** and press OK.

Removing USB storage devices



Caution

- In order to avoid damaging the USB storage device, please follow the steps below.

- 1 Press **↶** repeatedly to exit USB browser.
- 2 Wait for approximately five minutes before removing the USB storage device.

Updating the TV software

Philips constantly strives to improve its products, so we recommend that you update your TV software whenever an update becomes available. Please visit the website at www.philips.com/support to find out whether there are updates available.

Restoring the factory setup

You can restore your TV's default picture and sound setup. Saved channel setup will not be affected.

- 1 Press **🏠** (Home) and select Setup to enter the setup menu.
- 2 Press **▲▼◀▶** to select **[Settings]** > **[Reset]**.

6 Installing Channels

The first time you set up your TV, you are prompted to select a menu language and to install TV channels. This section provides instructions on how to re-install and fine-tune channels.

Setting up channels automatically

Automatically finds and saves channels. The channel grid appears.

- 1 Press **Home** (Home) and select Setup to enter the setup menu.
- 2 Press **▲▼◀▶** Select **[TV] > [Channels] > [Channel Scan]**.
- 3 Press **OK**.
↳ The TV will automatically start searching for channels.

Updating channels

- 1 Press **Home** (Home) and select Setup to enter the setup menu.
- 2 Press **▲▼◀▶** Select **[TV] > [Channels] > [Update Scan]**.
- 3 Press **OK**.
↳ The TV will start to update the channels.

Setting channels manually

You can manually find and save analog TV channels.

Finding and saving new TV channels

- 1 Press **Home** (Home) and select Setup to enter the setup menu.
- 2 Press to **▲▼◀▶** Select **[TV] > [Channels] > [Manual Search] > [Analog Manual Search]**.
↳ Show **[Manual Search]** menu.
- 3 Select **[Start frequency (MHz) / End Frequency (MHz)]** and use the number keys to enter the three-digit channel frequencies.
- 4 Select **[Start Search]** and press **OK**.
- 5 Press **Home** (Home) Exit.

Swapping channels

- 1 Press **Home** (Home) and select Setup to enter the setup menu.
- 2 Press **▲▼◀▶** Select **[TV] > [Channels] > [Channel Edit]**.
↳ The **[Channel Edit]** menu will be displayed.
- 3 Press **▲▼** Select the channel you wish to swap, then press the red button.
- 4 Press **▲▼** Select the channel you wish to swap, then press the red button to confirm.

Renaming channels

You can rename channels. Selecting a channel will display its name.

- 1 Press **Home** (Home) and select Setup to enter the setup menu.
- 2 Press **▲▼◀▶** Select **[TV] > [Channels] > [Channel Edit]**.

- ↳ The **[Channel Edit]** menu will be displayed.
- 3 Press ▲ ▼ to select the analog channel to be renamed, then press the OK button.
 - 4 Press ▲ ▼ Select the channel name, then press the OK button to enter the editing interface.
 - 5 Press ▲ ▼ ◀ ▶ Type the new name.
 - 6 Select **[Confirm]**, then OK to finish renaming the channel.

 **Note**

- Channel names can include a maximum of 6 characters.

7 Connecting Devices

This section describes how to connect devices with different connectors.

Note

- You can use different types of connectors to connect a device to your TV.

Bottom Connectors

① Component input (PC/Component input audio input)

- The analog audio and video input of the analog or digital devices, such as DVD players and game consoles.

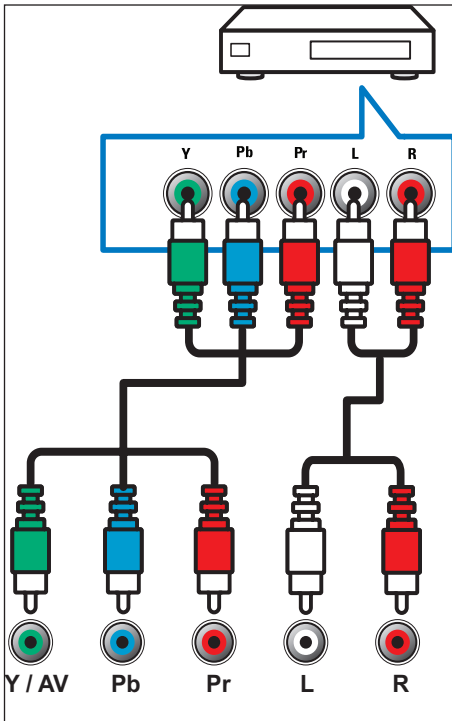

② AV Input

- Audio: Audio input from analogue devices connected to the video.
- Video: Composite video input from analogue devices such as VCR.

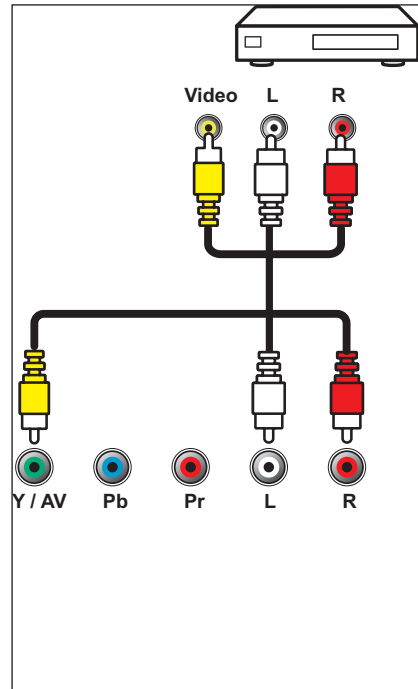

③ Antenna/cable TV

Signal input from an antenna or cable.

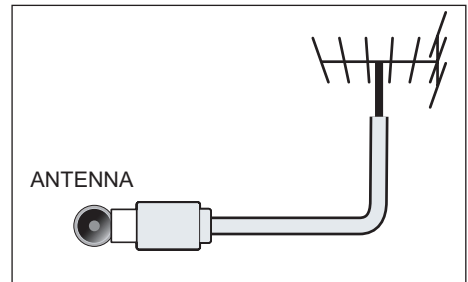

④ PC input (VGA and audio)

Audio and video input from a computer. (Note: The VGA interface of this product is designed to be slanted at 6 degrees. Please align properly with the interface when plugging and unplugging devices.)

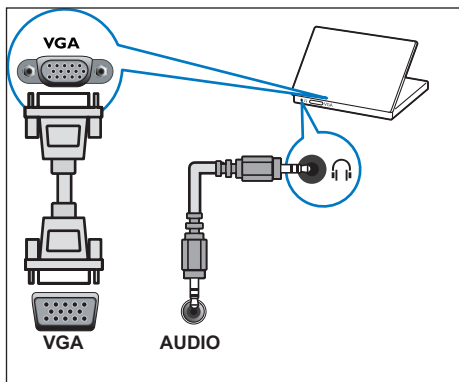

⑤ SPDIF

Transmit sound to digital audio signal, then connected audio device can play digital audio sound.

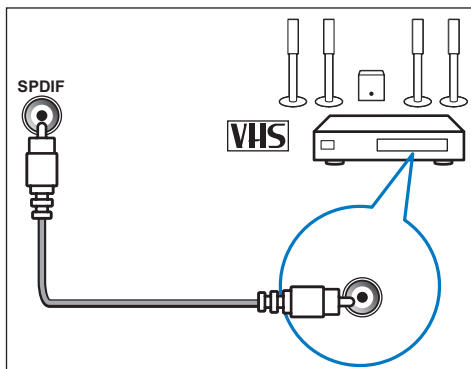

⑥ Headphone

Stereo audio output to headphones or earphones.

Note

- When the headphone is plugged in, the TV speakers will be automatically muted.

Side Connectors

- ① **USB**
Data input from USB storage devices.

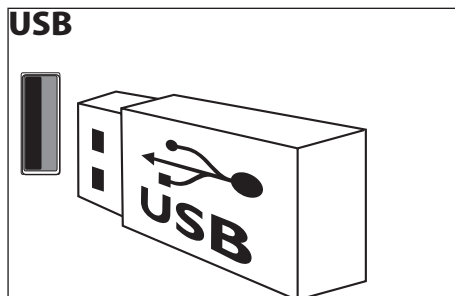

- ② **HDMI 1/HDMI 2 (MHL)/HDMI 3**
Digital audio and video input from high-definition digital devices such as Blu-ray players.

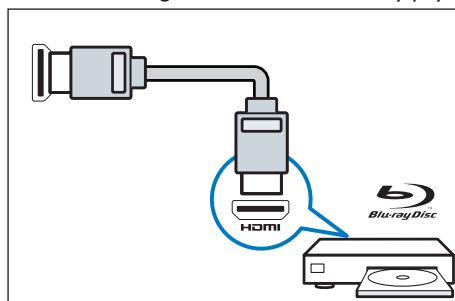

Connecting a Computer

Before you connect a computer to the TV

- Set the screen refresh rate on your computer to 60Hz.
- Select a supported screen resolution on your computer.

Connect a computer with one of the following connectors:

Note

- A separate audio cable is required when connecting with DVI or VGA.

- HDMI cable

- 1 Set the computer display resolution to 480p/576p/720p/1080p
- 2 Press **Home** (Home) and select Setup to enter the setup menu.
- 3 Press **▲▼◀▶** to select **[Settings]** > (HDMI Mode) and set the HDMI Screen Mode to PC or video.
- 4 Adjust picture format for the best display effect.
 - Press **Home** (Home) and select Setup to enter the setup menu.
 - Press **▲▼◀▶** Select **[Settings]** > **[Picture Format]**.
 - Select a picture format.
 - Press OK to confirm.

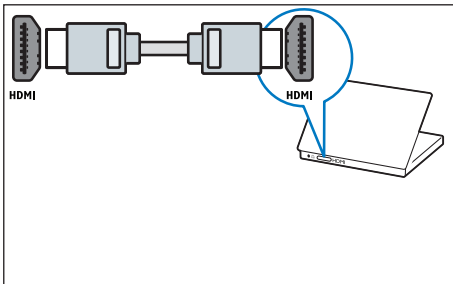

- DVI-HDMI cable

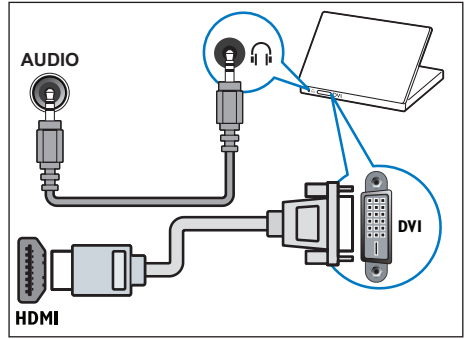

- HDMI cable and HDMI-DVI adaptor

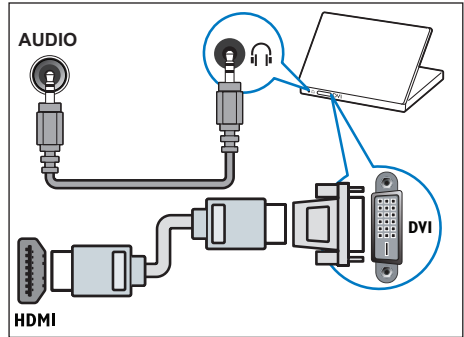

- VGA cable

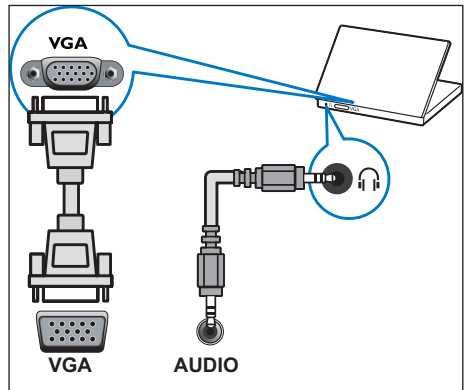

Using Philips EasyLink

Maximising the use of your Philips EasyLink HDMI-CEC-compatible device can enhance its control functions to the maximum level of efficiency. HDMI-CEC-compliant devices that are connected through HDMI connectors can be controlled by the TV's remote control.

To enable Philips EasyLink, you'll need to:

- Connect two or more HDMI-CEC compatible devices through the HDMI interface
- Confirm that every HDMI-CEC compatible device is functioning properly.
- Switch to EasyLink

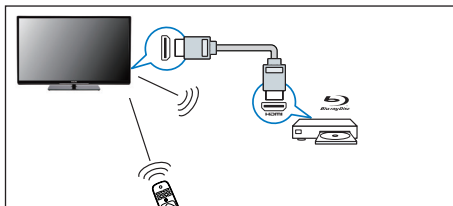

Note

- The EasyLink-compliant device must be switched on and selected as the source.
- Philips does not guarantee 100% interoperability with all HDMI CEC devices.
- HDMI 1, HDMI 2 and HDMI 3 have CEC functions.

Enabling or disabling EasyLink

After enabling the HDMI-CEC-compliant device, the TV will automatically turn on and switch to the correct source.

Note

- Do not enable Philips EasyLink if you do not intend to use it.

- 1 Press **Home** (Home).
- 2 Select **[Settings] > [EasyLink] > [EasyLink]**.
- 3 Select **[Off]** or **[On]** and press **OK**.

Use One-touch Play

- 1 After enabling EasyLink, press play on your device.
 - ↳ The TV will automatically switch to the correct source.

Use One-touch Standby

- 1 Press **Standby-On** on the remote control.
 - ↳ The TV and all connected HDMI devices will switch to standby.

Using a Kensington Security Lock

There is a Kensington security slot at the back of the TV. Prevent theft by looping a Kensington lock between the slot and a permanent object, such as a heavy table.

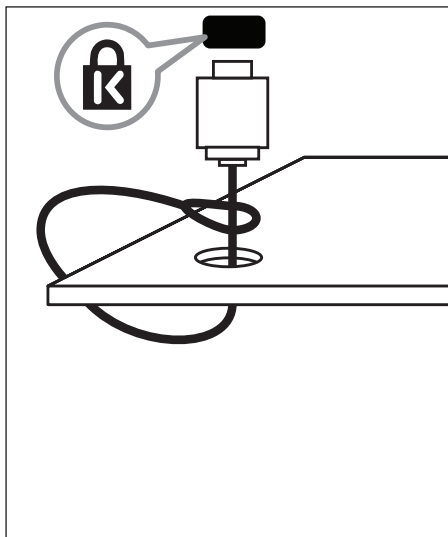

8 Product Information

Product information is subject to change without notice. For detailed product information, please visit www.philips.com/support

Supported Input Signal Formats

Computer Formats

- Resolution - refresh rate:
 - 640 × 480 - 60Hz
 - 800 × 600 - 60Hz
 - 1024 × 768 - 60Hz
 - 1360 × 768 - 60Hz
 - 1920 × 1080 - 60Hz

Video Formats

- Resolution - refresh rate:
 - 480i - 60Hz
 - 480p - 60Hz
 - 576i - 50Hz
 - 576p - 50Hz
 - 720p - 50Hz, 60Hz
 - 1080i - 50Hz, 60Hz
 - 1080p, 50Hz, 60Hz

Multimedia

- Supported storage device: USB (only FAT or FAT 32 USB storage devices are supported.)
- Compatible multimedia file formats:
 - Image: JPEG
 - Audio: MP3
 - Video: MPEG 2/MPEG 4, H.264
 - Text files: TXT

Tuner / Reception / Transmission

- Aerial input: 75 ohm coaxial (IEC75)
- TV system: PAL I, DTMB
- Video playback: NTSC, SECAM, PAL
- Tuner bands: UHF, VHF

Remote Control

- Battery: 2 × AAA (R03 Type)

Power

- Mains power: 110 - 240 V, 50-60 Hz
- Standby power: ≤ 0.5 W
- Ambient temperature: 5 to 40 degrees Celsius
- For power consumption, see the product specifications at www.philips.com/support.

Supported TV Mounts

To mount the TV, please purchase a Philips TV mount.



Warning

- Follow all instructions provided with the TV mount. TP Vision Europe B.V. bears no responsibility for improper TV mounting that results in accident, injury or damage.

- Please first lock the mount behind the TV.
- To prevent damage to cables and connectors, be sure to leave a clearance of at least 2.2 inches or 5.5cm from the back of the locked TV (including the protruding parts of the speakers) to the wall.
- Make sure that your mounting bolts follow these specifications:

Model No.	Required Pitch (mm)	Required Mounting Screws
43PPFD5100/30	200 × 200	4 × M6 (15 mm)

9 Troubleshooting

This section describes the commonly encountered issues and accompanying solutions.

General TV Issues

The TV does not switch on:

- Disconnect the power cable from the power outlet. Wait for one minute before reconnecting it.
- Check that the power cable is securely connected.

The remote control is not working properly:

- Check that the remote control batteries are correctly inserted according to the +/- orientation.
- Please replace the remote control batteries if they are flat or weak.
- Clean the remote control and TV sensor lens.

The standby light on the TV blinks red:

- Disconnect the power cable from the power outlet. Wait until the TV cools down before reconnecting the power cable. If the blinking continues to occur, please contact Philips Customer Care Centre.

You forgot the code to unlock the TV lock feature

- Enter '3448'.

The TV menu is displayed in the wrong language.

- Change the TV menu to your preferred language.

When turning the TV on/off or to standby, you hear a creaking sound from the TV chassis:

- No action is required. The creaking sound is normal expansion and contraction of the TV as it cools down and warms up. This does not impact performance.

TV Channel Issues

Previously installed channels do not appear in the channel list:

- Check that the correct channel list is selected.

Picture Issues

The TV is on, but there is no picture:

- Check that the antenna is properly connected to the TV.
- Check that the correct device is selected as the TV source.

There is sound but no picture:

- Check that the picture settings are correctly set.

There is poor TV reception from an antenna connection:

- Check that the antenna is properly connected to the TV.
- Loudspeakers, unearthed audio devices, neon lights, high buildings and other large objects can influence reception quality. If possible, try to improve the reception quality by changing the antenna direction or moving devices away from the TV.
- If reception on only one channel is poor, please fine tune this channel.

There is poor picture quality from connected devices:

- Check that the devices are connected properly.
- Check that the picture settings are correctly set.

The TV did not save your picture settings:

- Check that the TV location is set to the home setting. This mode offers you the flexibility to change and save settings.

The picture does not fit the screen; it is too big or too small:

- Try using a different picture format.

The picture position is incorrect:

- Picture signals from some devices may not fit the screen correctly. Please check the signal output of the device.

Sound Issues

There is a picture but sound quality is poor:

Note

- If no audio signal is detected, the TV automatically switches the audio output off - this does not indicate malfunction.
- Check that all cables are properly connected.
- Check that the volume is not set to 0.
- Check that the sound is not muted.

There is a picture but sound quality is poor:

- Check that the sound settings are correctly set.

There is a picture but sound comes from one speaker only:

- Verify that sound balance is set to the centre.

There is a picture in the TV channel, but the sound is noisy

- Check that the sound system setting of the channel settings is correctly set.

HDMI Connection Issues

There are problems with HDMI devices:

- Please note that HDCP (High-bandwidth Digital Content Protection) support can delay the time taken for a TV to display content from a HDMI device.
- If the TV does not recognise the HDMI device and no picture is displayed, please try switching the signal source from one device to another and back again.
- If there are intermittent sound disruptions, please check that output settings from the HDMI device are correct.

Computer Connection Issues

The computer display on the TV is not stable:

- Check that your PC uses the supported resolution and refresh rate.
- Set the TV picture format to unscaled.

Contact Us

If you cannot resolve your problem, please refer to the FAQs for this TV at www.philips.com/support.

If the problem remains unresolved, please contact the local Philips Customer Service Centre.



Warning

- Do not attempt to repair the TV yourself. This may cause severe injury, irreparable damage to your TV or void your warranty.



Note

- Please make a note of your TV model and serial number before you contact Philips Customer Service Centre. These numbers are printed on the back of the TV and on the packaging.

China's Marking Requirements for the Control of Pollution Caused by Electronic Information Products

Names and Levels of Hazardous Substances Contained in this Product

Part Name	Toxic Substances					
	Lead (Pb)	Mercury (Hg)	Cadmium (Cd)	Hexavalent chromium (Cr(VI))	Polybrominated biphenyls (PBB)	Polybrominated diphenyl ethers (PBDE)
Plastic frame	○	○	○	○	○	○
Rear chassis	○	○	○	○	○	○
LCD panel	CCFL	×	×	○	○	○
	LED	×	○	○	○	○
Power supply's baseplate	×	○	○	○	○	○
Main baseplate	×	○	○	○	○	○
Keypad baseplate	×	○	○	○	○	○
Base	○	○	○	○	○	○
Power cable	×	○	○	○	○	○
Other materials	×	○	○	○	○	○
Remote Control	×	○	○	○	○	○

*:The circuit board assemblies, including the printed circuit board and its component parts, such as resistors, capacitors, integrated circuits and connectors.

This table is compiled in accordance with SJ/T 11364 requirements.

O: indicates that the hazardous substance contained in all of the homogeneous materials for this part is below the limit requirement in GB/T 26572.

X: indicates that the hazardous substance contained in at least one of the homogeneous materials used for this part is above the limit requirement in GB/T 26572.

Note: In the parts marked "X" above, some of the hazardous substances have exceeded the limit requirements set out in GB/T 26572 in order to meet functional requirements, but are in compliance with the European Union's RoHS requirements (under the exemption section).



This electrical and electronic product contains some hazardous substances. You may be safe to use it during the environment-friendly use period, and please hand it over to recycle system after environment-friendly use period exceeded.

Suggestive description of the Recycling Administrative Regulations for Waste Electrical and Electronics Products

In order to care and protect the Earth in a better way, when the user no longer needs to use this product, or it has reached the end of the use period, please adhere to the national and applicable laws in relation to the recycling management of waste electrical and electronics products.

10 Warranty

English
Warranty

Български
Гаранция

Čeština
Záruka

Dansk
Garanti

Deutsch
Garantie

Ελληνικά
Εγγύηση

Eesti
Garantii

Español
Garantía

Français
Garantie

Hrvatski
Jamstvo

Italiano
Garanzia

Indonesia
Jaminan

Қазақша
Кепілдік

Latviešu
Garantija

Lietuvių
Garantija

Magyar
Garancia

Nederlands
Garantie

Norsk
Garanti

Polski
Gwarancja

Português
Garantia

Română
Garanție

Русский
Гарантия

Slovenščina
Garancija

Slovenský
Záruka

Srpski
Garancija

Suomi
Takuu

Svenska
Garanti

ไทย
การรับประกัน

Tiếng Việt
Bảo hành

Türkçe
Garanti

Українська
Гарантія

简体中文
保修

繁體中文
保養

العربية
الضمان

Malay
Waranti

Brazilian Portuguese
Garantia

English - Guarantee

Dear Customer,
Thank you for purchasing this Philips product. For the Philips warranty applicable to this product, we refer you to the Philips website www.philips.com/guarantee. In the event you do not have an internet connection, please contact your local Philips Consumer Care Centre. Contact details are given in the Consumer Care Centres list hereafter:

Български - Гаранция

Уважаеми потребители,
Благодарим Ви за закупуването на този продукт на Philips. За информация относно гаранцията на Philips, която важи за продукта, посетете сайта на Philips на адрес www.philips.com/guarantee. В случай че не разполагате с връзка с интернет, свържете се с местен център за обслужване на клиенти на Philips. Подробна информация за връзка е предоставена в списък с центрове за обслужване на клиенти по-долу.

Čeština - Záruka

Vážení zákazníci,
děkujeme za koupi toho produktu Philips. Záruku společnosti Philips platnou pro tento produkt naleznete na stránkách společnosti Philips na adrese www.philips.com/guarantee. Pokud nemáte k dispozici internetové připojení, obraťte se na místní středisko zákaznické podpory Philips. Kontaktní údaje jsou uvedeny v seznamu středisek zákaznické podpory níže.

Dansk - Garanti

Kære kunde,
Tak fordi du har købt dette Philips-produkt. For at få mere at vide om den Philipsgaranti, som anvendes til dette produkt, beder vi dig se Philips websted www.philips.com/guarantee. I tilfælde af, at du ikke har en internetforbindelse, bedes du venligst kontakte dit lokale Philips forbrugerservicecenter. Kontaktdetaljer oplyses på listen over forbrugerservicesteder herunder:

Deutsch - Garantie

Sehr geehrter Kunde, wir beglückwünschen Sie zu Ihrer Entscheidung für dieses Produkt von Philips. Nähere Informationen zu der für dieses Produkt geltenden Philips Garantie finden Sie im Internet unter www.philips.com/guarantee. Die durch Philips gewährte Garantie beeinträchtigt in keiner Weise Ihre gesetzlichen Rechte. Sofern Sie keinen Zugang zum Internet haben, wenden Sie sich bitte an Ihr Philips Info-Center vor Ort. Die entsprechenden Kontaktdaten entnehmen Sie bitte der nachstehenden Liste.

Ελληνικά - Εγγύηση

Αγαπητέ πελάτη,
Ευχαριστούμε που αγοράσατε αυτό το προϊόν Philips. Για την εγγύηση Philips που καλύπτει το συγκεκριμένο προϊόν, ανατρέξτε στον ιστότοπο της Philips www.philips.com/guarantee. Av

den διαθέσετε σύνδεση διαδικτύου, επικοινωνήστε με το τοπικό Κέντρο Εξυπηρέτησης Πελατών της Philips. Στοιχεία επικοινωνίας μπορείτε να βρείτε παρακάτω στον κατάλογο των Κέντρων Εξυπηρέτησης Πελατών.

Eesti - Garantii

Lugupidust klient,
Täname, et ostsite Philipsi toote. Tootele kehtiva Philipsi garantii leiate Philipsi veebi-saidilt www.philips.com/guarantee. Kui teil puudub Interneti-ühendus, võtke ühendust kohaliku Philipsi klienditeeninduskeskusega. Kontaktid leiate klienditeeninduskeskuste loendist.

Español - Garantía

Estimado cliente:
Le agradecemos la compra de este producto Philips. Para obtener detalles sobre la garantía Philips que se aplica a este producto, visite el sitio web de Philips en www.philips.com/guarantee. Si no tiene conexión a Internet, póngase en contacto con el Centro de atención al cliente de Philips local. Los datos de contacto se indican en la lista de centros de asistencia al cliente a continuación.

Français - Garantie

Cher client,
Merci d'avoir acheté ce produit Philips. Pour connaître les conditions de garantie Philips applicables à ce produit, reportez-vous à la page www.philips.com/guarantee. Si vous ne possédez pas de connexion Internet, contactez votre Service Consommateurs Philips local. Vous trouverez les coordonnées de tous les Services Consommateurs dans la liste ci-après. Ces informations étaient correctes à la date d'impression. Pour des informations à jour, consultez la page www.philips.com/support.

Hrvatski - Jamstvo

Poštovani kupče,
hvala vam što ste kupili ovaj Philipsov proizvod. Philipsovo jamstvo koje se odnosi na ovaj proizvod možete pronaći na Philipsovim internetskim stranicama www.philips.com/guarantee. Ako nemate pristup internetu, obratite se lokalnom Philipsovom Centru za korisnike. U nastavku se nalazi popis Centara za korisnike s podacima za kontakt.

Italiano - Garanzia

Gentile cliente,
grazie per aver acquistato questo prodotto Philips. Per informazioni sulla garanzia Philips applicabile a questo prodotto, è possibile fare riferimento al sito Web Philips www.philips.com/guarantee. Nel caso non disponesse di una connessione Internet, contatti il centro per il servizio clienti Philips locale. È possibile trovare le informazioni di contatto nell'elenco dei centri per il servizio clienti riportato di seguito.

Indonesia - Jaminan

Pelanggan yang terhormat,
Terima kasih telah membeli produk Philips. Untuk mendapatkan jaminan produk ini, kunjungi situs Web Philips di www.philips.com/guarantee. Jika Anda tidak memiliki sambungan Internet, hubungi Pusat Layanan Pelanggan Philips setempat. Rincian kontak tercantum dalam daftar Pusat Layanan Pelanggan.

Казакша - Кеңілдік

Құрметті, Тұтынушы
Мына Philips бұйымын сатып алғаныңызға алғысымызды білдіреміз. Бұл бұйымға қатысты Philips кеңілдігін алу үшін Philips компаниясының www.philips.com/guarantee веб-сайтын қараңыз. Интернетке қосыла алмаған жағдайда, жергілікті Philips тұтынушыларды қолдау орталығына хабарласыңыз. Байланыс мәліметтері осы құжаттың «Тұтынушыларды қолдау орталықтары» тізімінде берілген.

Latviešu - Garantija

Cien. klient!
Pateicamies, ka iegādājāties šo Philips produktu. Lai skatītu šī produkta Philips garantiju, apmeklējiet Philips vietni www.philips.com/guarantee. Ja jums nav pieejams internets, lūdzu, sazinieties ar vietējo Philips klientu apkalpošanas centru. Kontaktinformācija ir pieejama tālāk norādītajā klientu apkalpošanas centru sarakstā.

Lietuvių - Garantija

Gerb. kliente,
dėkojame, kad įsigijote „Philips“ gaminį. Jei norite sužinoti, kokia garantija taikoma šiam gaminiui, apsilankykite „Philips“ svetainėje www.philips.com/guarantee. Jei neturite interneto ryšio, susisiekite su vietos „Philips“ klientų aptarnavimo centru. Kontaktinę informaciją rasite toliau pateiktame klientų aptarnavimo centrų sąraše.

Magyar - Garancia

Kedves Vásárlónk!
Köszönjük, hogy ezt a Philips termékét választotta. A Philips termékre vonatkozó garanciáról a Philips webhelyén tájékozódhat: www.philips.com/guarantee. Ha nem rendelkezik internetkapcsolattal, forduljon a Philips helyi ügyfélszolgálatához. A kapcsolattartási adatokat az ügyfélszolgálatok listája tartalmazza az alábbiakban.

Nederlands - Garantie

Beste klant,
hartelijk bedankt voor uw aankoop van dit Philips-product. Voor informatie over de Philips-garantie die van toepassing is op dit product verwijzen wij u naar de Philips-website www.philips.com/guarantee. Hebt u geen internetverbinding, dan kunt u contact opnemen met uw lokale Philips Consumer Care Centre. Contactgegevens vindt u in de lijst met Consumer Care Centres.

Norsk - Garanti

Kjære kunde,
tak for at du kjøpte dette Philips-produktet. Se vårt webområde www.philips.com/guarantee som gjelder for dette produktet. Hvis du ikke har tilgang til Internett, kan du kontakte ditt lokale Philips-brukerstøttesenter. Du finner kontaktinformasjon i listen over brukerstøttesenter.

Polski - Gwarancja

Szanowni Kliencie!
Dziękujemy za nabycie tego produktu Philips. Aby sprawdzić gwarancję Philips mającą zastosowanie do tego produktu należy przejść do witryny internetowej firmy Philips pod adresem www.philips.com/guarantee. W przypadku nieposiadania łącza internetowego należy skontaktować się z lokalnym Centrum Obsługi Klienta firmy Philips. Informacje kontaktowe znajdują się na liście Centrów Obsługi Klienta.

Português - Garantia

Caro(a) Cliente,
Obrigado por adquirir este produto da Philips. Para obter a garantia da Philips aplicável a este produto, consulte o Web site da Philips www.philips.com/guarantee. Caso não tenha uma ligação à Internet, contacte o Centro de Assistência ao Cliente da Philips local. Os detalhes de contacto são fornecidos na lista de Centros de Assistência ao Cliente indicados a seguir.

Română - Garanție

Stimate client,
Vă mulțumim pentru că ați achiziționat un produs Philips. Pentru garanția Philips aplicabilă acestui produs, vă îndrumăm către site-ul Philips www.philips.com/guarantee. În cazul în care nu dispuneți de o conexiune la Internet, vă rugăm să contactați Centrul local Philips de asistență pentru consumatori. Datele de contact ale Centrelor de asistență pentru consumatori sunt disponibile în lista următoare.

Русский - Гарантия

Уважаемый потребитель!
Благодарим за покупку продукта Philips. Гарантия Philips для этого продукта опубликована на веб-сайте www.philips.com/guarantee. Если подключения к Интернету нет, обратитесь в местный центр поддержки потребителей Philips. Контактные данные приведены ниже в списке центров поддержки потребителей.

Slovenščina - Garancija

Spoštovani kupec!
Zahvaljujemo se vam za nakup Philipsovega izdelka. Informacije o Philipsovem jamstvu, veljavnem za ta izdelek, najdete na spletnem mestu www.philips.com/guarantee. Če nimate internetne povezave, se obrnite na krajevni Philipsov center za pomoč strankam. Podatki za stik so navedeni v

seznamu Philipsovih centrov za pomoč strankam v nadaljevanju.

Slovenský - Záruka

Vážení zákazníci,
děkujeme, že ste si kúpili produkt spoločnosti Philips. Ak si chcete pozrieť záručné podmienky vzťahujúce sa na tento produkt, odpoňčame Vám navštíviť stránku www.philips.com/guarantee. V prípade, že nemáte prístup k internetu, obráťte sa na miestne centrum podpory zákazníkov spoločnosti Philips. Kontaktné informácie nájdete v ďalej uvedenom zozname centier starostlivosti o zákazníkov.

Srpski - Garancija

Poštovani kupče!
Zahvaljujemo Vam na kupovini ovog Philipsovog proizvoda. Garanciju kompanije Philips koja se odnosi na ovaj proizvod možete pogledati na Philipsovoj Internet prezentaciji, na lokaciji www.philips.com/guarantee. Ukoliko ne posedujete vezu sa Internetom, molimo Vas da se obratite najbližem centru kompanije Philips za brigu o potrošačima. Detaljni podaci o kontaktu dati su u spisku centara za brigu o potrošačima.

Suomi - Takuu

Hyvää asiakas
Kitos, että ostit tämän Philips-tuotteen. Tuotetta koskevaan Philipsin takuuseen voit tutustua Philipsin sivustossa osoitteessa www.philips.com/guarantee. Jos sinulla ei ole Internet-yhteyttä, pyydämme sinua ottamaan yhteyttä Philipsin paikalliseen asiakaspalvelukeskukseen. Yhteyshiedot ovat jäljempänä olevassa asiakaspalvelukeskusten luettelossa.

Svenska - Garanti

Bästa kund,
Tack för att du har köpt den här Philips-produkten. Besök Philips webbplats www.philips.com/guarantee för information om den garanti som gäller för den här produkten. Om du inte har någon internetuppkoppling kan du kontakta din närmaste Philips-kundtjänst. Kontaktinformation finns i listan över kundtjänster nedan.

Türkçe - Garantisi

Değerli Müşterimiz,
Bu Philips ürününü satın aldığınız için teşekkür ederiz. Bu ürünün sahip olduğunuz Philips garantisini hakkında bilgi almak için www.philips.com/guarantee adresinden Philips web sitesini ziyaret etmenizi öneririz. İnternet bağlantınız yoksa, lütfen yerel Philips Tüketicileri İşçikleri Merkezi ile iletişime geçin. İletişim bilgileri, Tüketicileri İşçikleri Merkezleri listesinden verilmiştir.

Українська - Гарантія

Шановний покупць,
дякуємо за придбання цього виробу Philips. Гарантію Philips для цього виробу можна знайти на веб-сайті Philips за адресою www.philips.com/

guarantee. Якщо доступ до Інтернет відсутній, зверніться до місцевого центру обслуговування споживачів Philips. Контактна інформація наведена далі у списку центрів обслуговування споживачів.

ไทย - การรับประกัน

เรียนลูกค้า
ขอขอบคุณที่เลือกซื้อผลิตภัณฑ์ของ Philips สำหรับการรับประกันที่มีผลบังคับใช้กับผลิตภัณฑ์นั้น โปรดดูอ้างอิงเว็บไซต์ของ Philips www.philips.com/guarantee ในกรณีที่คุณไม่มีอินเทอร์เน็ต โปรดติดต่อศูนย์บริการลูกค้า Philips ประจำท้องถิ่นของคุณ รายละเอียดการติดต่อจะแสดงอยู่ในรายชื่อศูนย์บริการลูกค้าต่อไปนี้

Tiếng Việt - Bảo hành

Kính gửi Quý khách hàng,
Cảm ơn quý vị đã mua sản phẩm Philips này. Để biết bảo hành của Philips có thể áp dụng cho sản phẩm này, chúng tôi xin giới thiệu trang web của Philips www.philips.com/guarantee. Trong trường hợp quý vị không có kết nối internet, vui lòng liên hệ với Trung tâm Chăm sóc Khách hàng của Philips tại địa phương. Chi tiết liên hệ được cung cấp trong danh sách Trung tâm Chăm sóc Khách hàng sau đây.

简体中文 - 保证

尊敬的客户：
感谢您购买此 Philips 产品。有关适用于此产品的 Philips 保修信息，建议您访问 Philips 网站：www.philips.com/guarantee。如果您无法访问 Internet，请联系您当地的 Philips 客户服务中心。将来，我们会在客户服务中心列表中提供详细联系信息。

繁體中文 - 保證

親愛的客戶，您好：
多謝您購買本飛利浦產品。有關適用於本產品的飛利浦保養詳情，請瀏覽飛利浦網站：www.philips.com/guarantee。如您未能連線至互聯網，請與您當地的飛利浦消費者保養中心聯絡。聯絡詳情已詳列於之後的消費者保養中心清單中。

العربية الضمان

عزيزي العميل،
شكراً لكم على شراء هذا المنتج من Philips. لمعرفة شروط ضمان Philips الذي ينطبق على هذا المنتج، راجع موقع www.philips.com/guarantee. في حال لم يكن لديك اتصال بالإنترنت، يرجى الاتصال برقم مركز خدمة العملاء المحلي لشركة Philips. يمكن معرفة تفاصيل الاتصال من قائمة مراكز خدمة العملاء فيما يلي.

Inggeris-Jaminan

Pelanggan yang dihormati,
Terima kasih kerana membeli produk Philips. Bagi waranti Philips yang terpakai untuk produk ini, kami merujuk anda kepada laman web Philips www.philips.com/guarantee. Sekiranya anda tidak mempunyai sambungan Internet, sila hubungi Pusat Layanan Pelanggan Philips tempatan anda. Butiran kenalan diberikan dalam senarai Pusat Layanan Pelanggan selepas ini.

Português do Brasil

Caro cliente,
Obrigado por ter adquirido este produto Philips. Para obter a garantia Philips aplicável a este produto, consulte o site da Philips www.philips.com/guarantee. Caso você não tenha uma conexão de Internet, entre em contato com a Central de Atendimento ao Cliente Philips. Os detalhes de contato estão disponíveis na lista de Centrais de Atendimento ao Cliente a seguir.



User Manual



FAQ



Chat



Forum



Call



Email



Warranty

www.philips.com/support

България

Грижа за клиента
02 4916 273
(Национален номер)

België/Belgique

Klantenservice/
Service Consommateurs
02 700 72 62
(0,15€/min.)

Republika Srbija

Potpora potrošačima
011 321 6840
(Lokalni poziv)

Česká republika

Zákaznická podpora
228 880 895
(Místní tarif)

Danmark

Kundeservice
3525 8314

Deutschland

Kundendienst
069 66 80 10 10
(Zum Festnetzтариф ihres
Anbieters)

Ελλάδα

Τμήμα καταναλωτών
2111983028
(Διεθνής κλήση)

Eesti

Klienditugi
668 30 61
(Kohalikud kõned)

España

Atención al consumidor
913 496 582
(0,10€ + 0,08€/min.)

France

Service Consommateurs
01 57 32 40 50
(coût d'un appel local sauf
surcoût éventuel selon
opérateur réseau)

Hrvatska

Potpora potrošačima
01 777 66 01
(Lokalni poziv)

Ireland

Consumer Care
015 24 54 45
(National Call)

Italia

Servizio Consumatori
02 452 870 14
(Chiamata nazionale)

Қазақстан Республикасы

байланыс орталығы
810 800 2000 00 04
(стационарлық нөмірлерден
Қазақстан Республикасы
бойынша қоңырау шалу тегін)

Latvija

Klientu atbalsts
6616 32 63
(Vietēiais tarifs)

Lietuva

Klientų palaikymo tarnyba
8 521 402 93
(Vietiniais tarifais)

Luxembourg

Service Consommateurs
2487 11 00
(Appel national)/(Nation-
ale Ruf)

Magyarország

Ügyfélszolgálat
(061) 700 81 51
(Belföldi hívás)

Nederland

Klantenservice
0900 202 08 71
(0,10€/min.)

Norge

Forbrukerstotte
22 97 19 14

Österreich

Kundendienst
49 34 02 30 53 47
(0,145€/Min.)

Республика Беларусь

Контакт Центр
8 10 (800) 2000 00 04
(бесплатный звонок по
Республике
Беларусь со стационарных
номеров)

Российская Федерация

Контакт Центр
8 (800) 220 00 04
(бесплатный звонок по
России)

Polska

Wspieranie Klienta
22 397 15 04
(Połączenie lokalne)

Portugal

Assistência a clientes
800 780 068
(0,12€/min. – Móvel
0,30€/min.)

România

Serviciul Clienti
031 630 00 42
(Tarif local)

Schweiz/Suisse/Svizzera

Kundendienst/
Service Consommateurs/-
Servizio Consumatori
0848 000 291
(0,081 CHF/Min)

Slovenija

Skrb za potrošnike
01 888 83 12
(Lokalni klic)

Slovensko

Zákaznická podpora
02 332 154 93
(vnútroštátny hovor)

Suomi

Finland Kuluttajapalvelu
09 88 62 50 40

Sverige

Kundtjänst
08 57 92 90 96

Türkiye

Tüketici Hizmetleri
0 850 222 44 66

Україна

Служба підтримки
споживачів
0-800-500-480
(дзвінки зі стаціонарних
телефонів безкоштовні)

United Kingdom

Consumer Care
020 79 49 03 19
(5p/min BT landline)

Argentina

Consumer Care
0800 444 77 49
– Buenos Aires
0810 444 77 82

Brasil

Suporte ao Consumidor
0800 701 02 45
– São Paulo
29 38 02 45

Middle East and Africa

+971 4 2570007

South Africa

03 5667 8250
(Local tariffs)

Australia

1300 886 649

Hong Kong/香港

(852)26199639

India/भारत

1860 180 1111

Indonesia

0852-8902-8902

Korea/한국

080-600-6600

Malaysia

1800 220 180

New Zealand

0800 836 761

Pakistan/پاکستان

(051)-580902-3

Philippines/Philipinas

(02) 8424970

Singapore/新加坡

65-62867333

Taiwan/台灣

0800 558 068

Thailand/ประเทศไทย

02 640 3000

Vietnam/ Việt Nam

1800.59.99.88



All registered and unregistered trademarks are property of their respective owners.

Specifications are subject to change without notice. Philips and the Philips' shield emblem are trademarks of Koninklijke Philips N.V. and are used under license from Koninklijke Philips N.V. 2015 © TP Vision Europe B.V. All rights reserved.

philips.com