

Register your product and get support at

www.philips.com/welcome

40PFA4500

50PFA4500

55PFA4500

EN User manual

PHILIPS

Contents

1	Caution	2
2	Important	3
	Safety	3
3	Your TV	5
	Control Panel	5
	Remote Control	5
	Remote control usage	6
4	Use your TV	7
	Switch TV on or off	7
	Switch channels	7
	Watch connected devices	8
	Adjust TV volume	8
5	Other uses of the TV	9
	Accessing the TV menu	9
	Change the picture and sound setup	9
	Settings	10
	Use timer	11
	Adjusting VGA Setup	12
	Playing media from USB devices	12
	Updating the TV software	13
	Restoring the factory setup	13
6	Setting up channels	15
	Setting up channels automatically	15
	Setting channels manually	15
	Renaming channels	15

7	TV connections	16
	Rear connections	16
	Side connections	17
	Connecting to a computer	18
	Use Philips EasyLink	19
8	Product information	20
	Display resolutions	20
	Multimedia	20
	Audio Output Power	20
	Inherent resolution	20
	Tuner / Reception / Transmission	20
	Remote Control	20
	Power Supply	20
	Supported TV mounts	21
9	Troubleshooting	22
	General issues	22
	Channel issues	22
	Picture issues	22
	Sound issues	23
	HDMI connection issues	23
	Computer connection issues	23
	Contact us	23
10	Warranty	25

1 Caution

2015©TPVision Europe B.V. All rights reserved. Specifications are subject to change without notice. Trademarks are the property of Koninklijke Philips N.V. or their respective owners. TPVision Europe B.V. reserves the right to change products at any time without being obliged to adjust earlier supplies accordingly. The material in this manual is believed adequate for the intended use of the system. If the product, or its individual modules or procedures, are used for purposes other than those specified herein, confirmation of their validity and suitability must be obtained. TPVision Europe B.V. warrants that the material itself does not infringe any United States patents. No further warranty is expressed or implied. TPVision Europe B.V. cannot be held responsible neither for any errors in the content of this document nor for any problems as a result of the content in this document. Errors reported to Philips will be adapted and published on the Philips support website as soon as possible.

Terms of warranty

- Risk of injury, damage to TV or void of warranty! Do not attempt to repair the TV yourself.
- Use the TV and accessories only as intended by the manufacturer.
- The caution sign printed on the back of the TV indicates risk of electric shock. Never remove the TV cover. Always contact Philips Customer Support for service or repairs.
- Any operation expressly prohibited in this manual, or any adjustments and assembly procedures not recommended or authorised in this manual shall void the warranty.

Pixel characteristics

This LCD/LED product has a high number of color pixels. Although it has effective pixels of 99.999% or more, black dots or bright points of light (red, green or blue) may appear constantly on the screen. This is a structural property of the display (within common industry standards) and is not a malfunction.

Mains fuse (/56)

This TV is fitted with an approved moulded plug. Should it become necessary to replace the mains fuse, this must be replaced with a fuse of the same value as indicated on the plug (example 10A).

- 1 Remove fuse cover and fuse.
- 2 The replacement fuse must comply with BS 1362 and have the ASTA approval mark. If the fuse is lost, contact your dealer in order to verify the correct type.
- 3 Refit the fuse cover.

Copyright



®Kensington and Micro Saver are registered US trademarks of ACCO World corporation with issued registrations and pending applications in other countries throughout the world.



HDMI, the HDMI logo and High-Definition Multimedia Interface are trademarks or registered trademarks of HDMI licensing LLC in the United States and other countries. All other registered and unregistered trademarks are the property of their respective owners.



This product is manufactured under license from Dolby Laboratories. Dolby and the double-D symbol are registered trademarks of Dolby Laboratories.

MHL

MHL, Mobile High-Definition Link and the MHL Logo are trademarks or registered trademarks of the MHL, LLC.

2 Important

Read and understand all instructions before you use your TV. If damage is caused by failure to follow instructions, the warranty does not apply.

Safety

Risk of electric shock or fire!

- Never expose the TV to rain or water. Never place liquid containers, such as vases, near the TV. If liquids are spilt on or into the TV, disconnect the TV from the power outlet immediately. Contact Philips Consumer Care to have the TV checked before use.
- Never place the TV, remote control or batteries near naked flames or other heat sources, including direct sunlight. To prevent the spread of fire, keep candles or other flames away from the TV, remote control and batteries at all times.



- Never insert objects into the ventilation slots or other openings on the TV.
- When the TV is swivelled ensure that no strain is exerted on the power cord. Strain on the power cord can loosen connections and cause arcing.
- To disconnect the TV from the mains power, the power plug of the TV must be disconnected. When disconnecting the power; always pull the power plug, never the cord. Ensure that you have full access to the power plug, power cord and outlet socket at all times.

Risk of short circuit or fire!

- Never expose the remote control or batteries to rain, water or excessive heat.
- Avoid force coming onto power plugs. Loose power plugs can cause arcing or fire.

Risk of injury or damage to the TV!

- Two people are required to lift and carry a TV that weighs more than 25 kg or 55 lbs.
- When stand mounting the TV, use only the supplied stand. Secure the stand to the TV tightly. Place the TV on a flat, level surface that can support the combined weight of the TV and the stand.
- When wall mounting the TV, use only a wall mount that can support the weight of the TV. Secure the wall mount to a wall that can support the combined weight of the TV and wall mount. TP Vision Europe B.V. bears no responsibility for improper wall mounting that results in accident, injury or damage.
- If you need to store the TV, disassemble the stand from the TV. Never lay the TV on its back with the stand installed.
- Before you connect the TV to the power outlet, ensure that the power voltage matches the value printed on the back of the TV. Never connect the TV to the power outlet if the voltage is different.
- Parts of this product may be made of glass. Handle with care to avoid injury and damage.

Risk of injury to children!

Follow these precautions to prevent the TV from toppling over and causing injury to children:

- Never place the TV on a surface covered by a cloth or other material that can be pulled away.
- Ensure that no part of the TV hangs over the edge of the surface.
- Never place the TV on tall furniture (such as a bookcase) without anchoring both the furniture and TV to the wall or a suitable support.
- Educate children about the dangers of climbing on furniture to reach the TV.

Risk of swallowing batteries!

- The product/remote control may contain a coin-type battery, which can be swallowed. Keep the battery out of reach of children at all times!

Risk of overheating!

- Never install the TV in a confined space. Always leave a space of at least 4 inches or 10 cm around the TV for ventilation. Ensure curtains or other objects never cover the ventilation slots on the TV.

Risk of injury, fire or power cord damage!

- Never place the TV or any objects on the power cord.
- Disconnect the TV from the power outlet and antenna before lightning storms. During lightning storms, never touch any part of the TV, power cord or antenna cable.

Risk of hearing damage!

- Avoid using earphones or headphones at high volumes or for prolonged periods of time.

Low temperatures

- If the TV is transported in temperatures below 5°C or 41°F, unpack the TV and wait until the TV temperature matches room temperature before connecting the TV to the power outlet.

Screen care

- Avoid stationary images as much as possible. Stationary images are images that remain on-screen for extended periods of time. Example: on-screen menus, black bars and time displays. If you must use stationary images, reduce screen contrast and brightness to avoid screen damage.
- Unplug the TV before cleaning.
- Clean the TV and frame with a soft, damp cloth. Never use substances such as alcohol, chemicals or household cleaners on the TV.
- Risk of damage to the TV screen! Never touch, push, rub or strike the screen with any object.
- To avoid deformations and color fading, wipe off water drops as soon as possible.



Note

Stationary images may result in permanent damage to the TV screen.

- Do not display stationary images on the LCD screen for more than two hours as this may result in ghost images. To prevent this, reduce screen brightness and contrast.
- Viewing programs in the 4:3 format for extended periods of time may leave different traces on the left and right edges of the screen as well as along the borders

of the image. Avoid using this mode for extended periods of time.

- Displaying stationary images from video games or computers for an extended period of time may result in partial after-images and the appearance of ghost images caused by screen burn. Reduce screen brightness and contrast accordingly when using the TV in this way.

Ghost images, partial after-images, and other traces that appear on the TV screen as a result of the above are not covered by the warranty.

Recycling



Your product is designed and manufactured with high quality materials and components, which can be recycled and reused.



When this crossed-out wheeled bin symbol is attached to a product it means that the product is covered by the European Directive 2002/96/EC. Please inform yourself about the local separate collection system for electrical and electronic products.

Please act according to your local rules and do not dispose of your old products with your normal household waste.

Correct disposal of your old product helps to prevent potential negative consequences for the environment and human health.



Your product contains batteries covered by the European Directive 2006/66/EC, which cannot be disposed of with normal household waste. Please inform yourself about the local rules on separate collection of batteries because correct disposal helps to prevent negative consequences for the environment and human health.

3 Your TV

Congratulations on your purchase, and welcome to Philips! To fully benefit from the support that Philips offers, register your TV at www.philips.com/welcome.

Control Panel

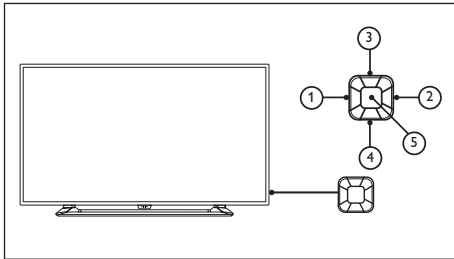

- ① **Volume-**: Without the key menu, the volume-down function is available.
- ② **Volume+**: Without the key menu, the volume-up function is available.
- ③ **Channel+**: When there is no keyboard menu, switch to the next channel function; when the keyboard menu appears, move up and down the appropriate options.
- ④ **Channel-**: When there is no keyboard menu, switch to the prior channel function; when the keyboard menu appears, move up and down the appropriate options.
- ⑤ **Signal source/OK**: In standby, the signal source/OK key is used as a power key. Press this key to boot. After booting, the signal source/OK key is used to open the keyboard menu functions. When the keyboard menu is open, the signal source/OK key is used as a confirmation key.
Note: The signal source/OK key has no function in USB mode

Remote Control

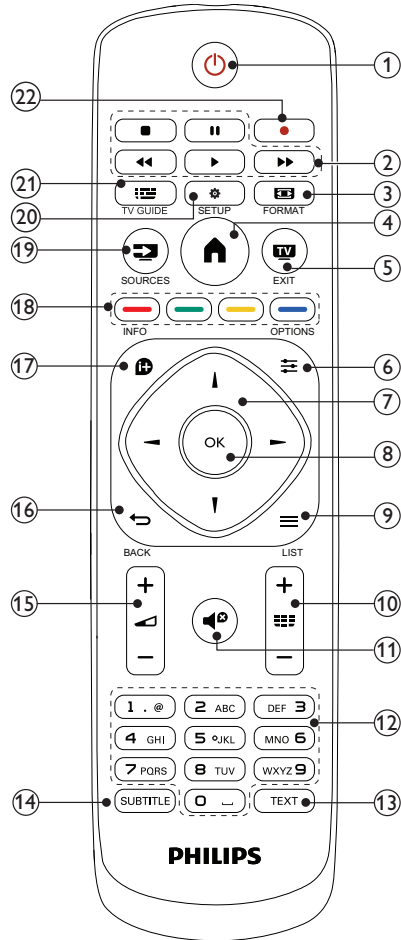

- ① **⏻ (Standby)**
Switch the TV on or to standby.
- ② **Play buttons**
Control video, music or text.
- ③ **FORMAT**
Change picture format.
- ④ **Home**
Access or exit from the main menu and return to the previous menu.

- 5 **TV EXIT**
Switches to TV.
- 6 **≡ OPTIONS**
Access options for channels in the TV mode.
- 7 **▲ ▼ ◀ ▶ (Navigation buttons)**
Navigate through menus and select items.
- 8 **OK**
Confirm an entry or selection.
- 9 **≡ LIST**
Access or exit from the TV channel list.
- 10 **CH +/- (Channel +/-)**
Changes channels; scrolls up/down through the options in USB mode.
- 11 **🔇 (Mute)**
Mute or restore audio.
- 12 **0-9 (Numeric buttons)**
Select channel.
- 13 **TEXT**
Enable or disable teletext.
- 14 **SUBTITLE**
Selects subtitles.
- 15 **+/- (Volume)**
Adjust volume.
- 16 **↶ (Back)**
Return to the previous menu or exit from a certain function, and switch to the previous channel or signal source.
- 17 **ℹ INFO**
Display information about current activity.
- 18 **Color buttons**
Select tasks or options.
- 19 **📺 SOURCE**
Select connected devices
- 20 **⚙️ SETUP**
Accesses TV setup menu.
- 21 **📺 TV GUIDE**
Accesses or exits the TV channels list.
- 22 **● Red**
The red key has no function

Remote control usage

When you use the remote control, hold it close to the TV and point it at the remote control sensor. Make sure that the line-of-sight between the remote control and TV is not blocked by furniture, walls or other objects.

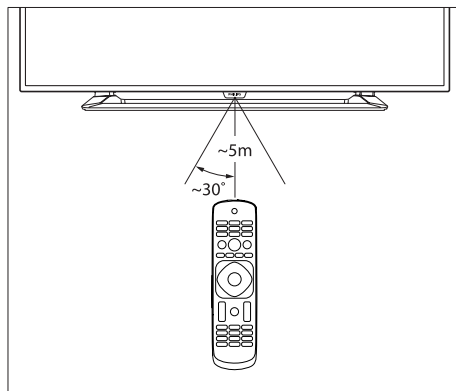

4 Use your TV

This section helps you perform basic TV operations.

Switch TV on or off

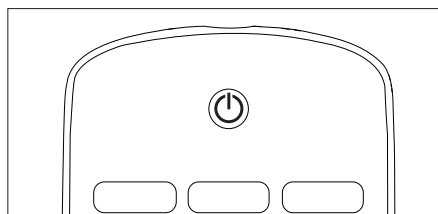
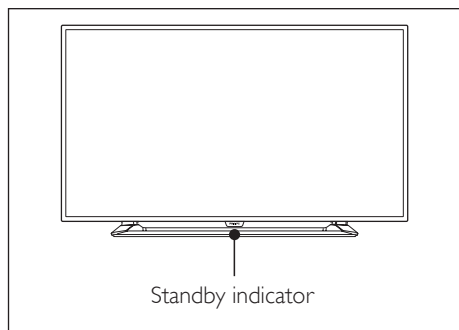

To switch on

- Plug in the power plug.
 - ↳ If the standby indicator is red, press (Standby-On) on the remote control.

To switch to standby

- Press (Standby-On) on the remote control.
 - ↳ The standby indicator switches to red.



Tip

- Though your TV consumes very little power when in standby mode, energy continues to be consumed. When not in use for an extended period of time, disconnect the TV power cable from the power outlet.

Switch channels

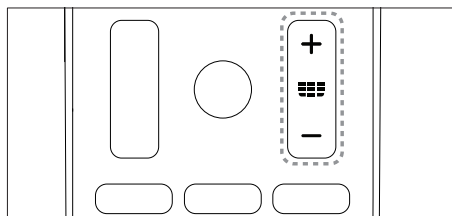
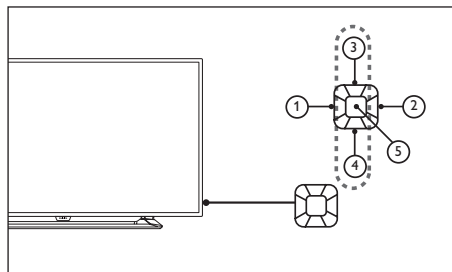

- Press **CH +/-** on the remote control or the lower right part of the TV.
- Enter a channel number using the numeric buttons on the remote control.
- Press on the remote control to switch and return to the previous channel.

View installed channel

You can view all available channels on the channel list.

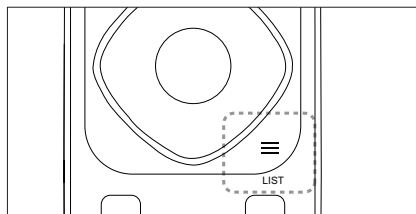

- 1 Press **LIST**.
 - ↳ The channel list appears.
- 2 Press to select a channel and browse the channel list.
- 3 Press **OK** to watch the selected channel.
- 4 Press to switch to and resume the last watched channel.

Watch connected devices

Note

- Switch on the device before selecting it as an external signal source.

Use the Source button

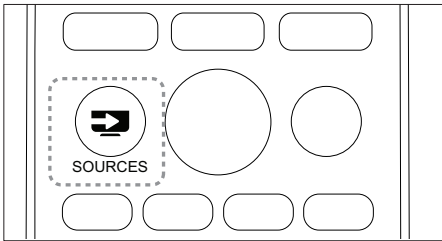

- 1 Press **SOURCE**.
↳ The source list appears.
- 2 Press **◀▶** to select a device.
- 3 Press **OK** to select.
↳ The TV switches to the selected device.

Adjust TV volume

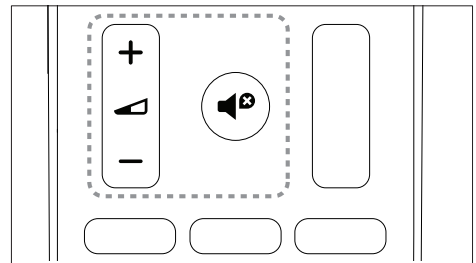
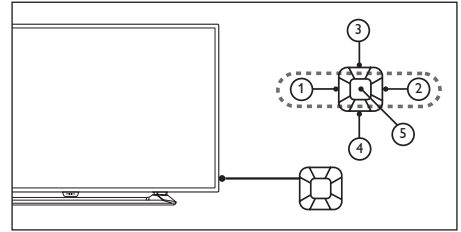

To increase or decrease volume

- Press **VOL +/-** at the lower right part of the TV or the **Volume Control +/-** on the remote control.

To mute or unmute sound

- Press **Mute**.
- Press **Mute** again to restore the sound.

5 Other uses of the TV

Accessing the TV menu

The menu can help you to set up channels, change the picture and sound setup, and access other functions.

- 1 Press **Home** .
↳ Display menu screen.

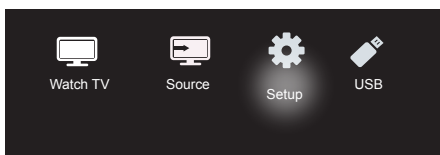

- 2 Select **[Setup]**.
- 3 Press **▲▼◀▶** Choose from the following options:
 - **[Picture]** / **[Sound]** / **[TV]** (available only in TV mode) / **[Settings]** / **[Parental]** / **[VGA Setting]** (available only in PC mode) / **[EasyLink]**.
- 4 Press **OK** to select.
- 5 Press **Home** to go back.

Change the picture and sound setup

Change the picture and sound setup to suit your preferences. You can either use the presets or manually change the setup.

Adjusting the picture setup

- 1 Press **Home**, then select Setup to enter the setup menu and select **[Picture]**.
↳ Displays the **[Picture]** menu..

- 2 Press **▲▼◀▶** Selecting/adjusting setup:
 - **[Smart picture]**:
 - **[Standard]**: Normal picture setup. Recommended for home entertainment use.
 - **[Eco]**: Decreases the intensity of the backlight to reduce power consumption.
 - **[Vivid]**: Increases the contrast and sharpness of the picture.
 - **[Movie]**: Applies setup for watching movies, which works best in a theater environment.
 - **[Personal]**: Users can define custom setup here.
 - **[Brightness]**: Adjusts the intensity and detail of dark areas (adjustments made can only be saved in personal setup).
 - **[Video contrast]**: Adjusts the intensity and detail of bright areas, with dark areas remaining unchanged (adjustments made can only be saved in personal setup).
 - **[Color]**: Adjusts the color saturation (adjustments made can only be saved in personal setup).
 - **[Tint]**: Adjusts the level of green (this option only appears when using the NTSC standard).
 - **[Sharpness]**: Adjusts the sharpness of the image (adjustments made can only be saved in personal setup).
 - **[Color Temperature]**:
 - **[Cool]**: Bluish white tint.
 - **[Normal]**: White tint. Users can personalize the white tint in PC mode.
 - **[Warm]**: Reddish white tint.
 - **[Advanced control]**:
 - **[Noise Reduction]**: Filters and eliminates signal noise within the image.
 - **[Backlight]**: Adjusts the screen brightness (when the backlight brightness is set to a low value, a momentary white flicker may be visible when turning on the unit. This is normal. When **[Dynamic Backlight]** is turned on, this function will be hidden).
 - **[Dynamic Contrast]**: Sets the contrast to maximum. (There are no advanced contrast functions in PC mode.)

- **[Dynamic Backlight]:** The contrast level will change with the brightness of the image.

Note

- The options may vary for different signal sources.

Adjusting the sound setup

- 1 Press **⏠ (Home)**, then select Setup to enter the setup menu and select **[Sound]**.
↳ Displays **[Sound]** menu.
- 2 Press **▲▼◀▶** Select and adjust the setup:
 - **[Smart Sound]:**
 - **[Standard]:** Gives balanced, outstanding sound performance in the treble, mid and bass ranges.
 - **[Music]:** Enhances treble and bass, delivering bright, clear and pure sound quality when listening to piano or orchestral instrument performances.
 - **[Movie]:** Enhance sound quality of movies to enjoy a cinema-like effects at home.
 - **[Personal]:** Provides user customization functions in order to optimize all sound effect parameters and achieve the best experience.
 - **[Balance]:** Adjusts the balance of the left and right speakers.
 - **[Bass]:** Adjusts the bass level (adjustments made can only be saved in personal setup).
 - **[Treble]:** Adjusts the treble level (adjustments made can only be saved in personal setup).
 - **[Virtual surround]:** Turns virtual surround sound on: Turn on or off.
 - **[SPDIF Mode]:** Selects the SPDIF output mode.
 - **[AVL]:** Turns automatic volume adjustment on.

Settings

- 1 Press **⏠ (Home)**, then select Setup to enter the setup menu and select **[Settings]**.
↳ Displays **[Settings]** menu.
- 2 Press **▲▼◀▶** Select and adjust the setup:
 - **[Menu language]:** Changes the TV's language setup.
 - **[Picture Format]:** The majority of signals use 16:9, 4:3, Zoom 1 and Zoom 2 formats; HDMI signal sources use 16:9, 4:3, Point to Point, zoom 1 and zoom 2 formats; VGA signal sources on PCs use 16:9, 4:3 and Point to Point formats.
 - **[Menu Timeout]:** Sets the duration for which the menu is displayed.
 - **[Menu Transparency]:** Sets the level of transparency for the menu.
 - **[Blue Screen]:** Sets the screen color for when the TV is not receiving a signal (when the TV signal is not functioning).
 - **[Auto Sleep]:** Sets the duration for which the TV remains idle before it automatically enters standby mode. (Not applicable in PC mode).
 - **[Sleep Timer]:** (Sleep Timer): Sets the duration before the TV automatically enters standby mode. Options: Off/10/20/30/60/90/180 minutes.
 - **[Power On Status]:** Sets the TV's status when it is connected to an AC power supply.
 - **[Freeze Switch]:** Turns on or off the option to freeze the picture when changing channels.
 - **[TTX Language]:** Sets the TTX language (only available in TV mode).
 - **[Color System]:** Sets the AV color system. (Only displayed in AV mode)
 - **[HDMI]:** Sets the HDMI mode. (Only displayed in 480p/576p/720p/1080p HDMI modes. PC mode is recommended when connecting a PC.)
 - **[Reset]:** Restores the default setup. (Excluding password setup and channel information)

Changing picture format

- 1 Press **Home** (Home), then select Setup to enter the setup menu and select **[Settings]**.
- 2 Press to **▲▼◀▶** select **[Picture Format]**.
- 3 Select a **picture format**.
- 4 Press **OK** to confirm.

Summary of picture formats

Configuration of the picture setup listed below.



Notes

- Some picture setups may be unavailable due to differences between picture signal formats.



[16:9]: Change the normal ratio to widescreen format.



[4:3]: The normal format.



[Zoom 1]: Horizontal scaling of the widescreen picture format. When this format is used, the two edges of the picture frame will be partly cut off.



[Zoom 2]: Set the normal ratio to widescreen format. (Only 16:9, 4:3, and Point to Point are available in PC mode).



[Point to Point]: Used for HDMI connections on PCs. Will display the PC's full screen in order to achieve the best display effect.

Use timer

You can set the timer to switch the TV to standby mode at a set time.



Tip

- Before using the timer, please set the sleep timer.

Setting the sleep timer



Tip

- You can turn the TV off earlier, or reset the sleep timer before the TV switches off.

- 1 Press **Home** (Home), then select Setup to enter the setup menu and select **[Settings]**.
- 2 Press to **▲▼◀▶** Select **[Sleep Timer]**.
- 3 Press **▲▼** You can select a time for the sleep timer to turn the TV off.
 - ↳ The longest time that can be set for the sleep timer is 180 minutes.

TV lock

By locking the TV remote control, you can prohibit children from watching specific programs or channels.

Setting or changing your password

- 1 Press **Home** (Home), then select Setup to enter the setup menu and select **[Parental]**.
- 2 Use the number buttons on the remote control to enter a password.
- 3 Select (Change Password) and follow the instructions on screen.

Locking channels

- 1 Press **Home** (Home), then select Setup to enter the setup menu and select **[Parental]**.
- 2 Enter the password and select **[Channel Lock]**.

- 3 Choose a channel. Press **OK** to lock or unlock the channel.
- 4 Repeat this step to lock or unlock multiple channels.
 - **[Channel Lock]:** When channels are locked:
 - A four-digit password is required to enter the channel search menu.
 - You need to enter the four digit password to watch locked channels.
 - You need to enter the four digit password to enter the parental menu.
 - **[Clear All]:** This function will clear all the locked channels and signal sources that you have previously saved.
 - The default password is "0000". Users may change or set the password themselves.

Notes

- If you visit a locked channel, you will be prompted to enter the password.

Adjusting VGA Setup

- 1 Press **⬆️** (**Home**), then select Setup to enter the setup menu and select **[VGA setting]**.
↳ The **[VGA setting]** menu will be displayed.
- 2 Press **⬆️** Select and adjust the setup:
 - **[Auto adjust]:** Automatically adjusts the TV to synchronize its resolution with that of the PC, so that programs are displayed in full screen.
 - **[H.Position]:** Adjusts the horizontal position.
 - **[V.Position]:** Adjusts the vertical position.
 - **[Phase]:** Adjusts the phase frequency of the VGA signal.
 - **[Clock]:** Adjusts the clock frequency of the VGA signal.

Tip

- The VGA menu is only visible when connected to a PC.

Playing media from USB devices

If you have photos, music or video files stored on a USB storage device, you can play the files on your TV.

- Supported storage devices: USB (only FAT or FAT 32 USB storage devices are supported)
- Supported media file formats:
 - Images: JPEG
 - Audio: MP3
 - Video: MPEG 2/MPEG 4, H.264
 - Text files: TXT

Note

- TP Vision shall not be liable if a USB storage device is not supported, or if the data in the device is damaged or lost.

Viewing pictures and playing audio, text and video files

- 1 Turn on the TV.
- 2 Connect the USB storage device to the USB port on the side of the TV.
- 3 Press **⬆️** (**Home**).
- 4 Select **[USB]** and press **OK**.
↳ The USB browser will open.

Viewing photos

- 1 In the USB browser, select **[Photo]** and press **OK**.
- 2 Select a photo then press **OK**. The photo will be enlarged to fill the screen.
 - Press **CH-** or **CH+** to see the previous or next photo.

Starting slide shows

- 1 Select a photo or folder; then press **OK**. The photo will be enlarged to fill the screen.
↳ The slide show starts playing from the selected photo.

- 2 Press the following buttons to control photo playback:
 - **▶** or **||** : Play or pause
 - **CH-** or **CH+**: See the last photo or the next photo.
- 3 Press the INFO button for graphic display of basic information

Listening to music

- 1 In the USB browser, select **[Music]** and press **OK**.
- 2 Select a song or album, then press **OK** to start playing.
- 3 Use the following buttons to control music:
 - **▶** or **||** : Play or pause
 - **⏮**/**⏭**/**⏪**/**⏩**: Adjust Smart sound

Watching video

- 1 In the USB browser, select **[Movie]**, then press **OK**.
- 2 Press **OK** to play the video.
- 3 Use the following buttons to control the movie:
 - **▶** or **||** : Play or pause
 - **⏮**/**⏭** : Search forward or backward.

Change video setting

When playing a video, press INFO for the setting menu, press **▲▼◀▶**, then choose the relevant setting and make adjustments accordingly:

- **[Smart picture]**: Setting the playback mode of the screen.
- **[Smart sound]**: Setting the playback mode of the sound.
- **[Sound track]**: Adjust sound track (adjustments cannot be made without sound track).
- **[Subtitles]**: Adjust subtitle (adjustments cannot be made without subtitles).
- **[Resolution]**: Display video resolution (no option available).

- **[Size]**: Display size of video (no option available).
- **[Close]**: Close menu.

Viewing documents

- 1 In the USB browser, select **[Text]**, then press **OK**.
- 2 Press **OK** to read the text file.
- 3 Use the following buttons to control text file playback:
 - **▶** or **||** : Play or pause
 - **⏮**/**⏭** : Search forward or backward.
- 4 Press INFO button to display text size.

Removing USB storage devices



Note

- In order to avoid damaging the USB storage device, please follow the steps below.

- 1 Press **⏪** (**Back**) repeatedly to exit the USB browser.
- 2 Wait for approximately five minutes before removing the USB storage device.

Updating the TV software

Philips constantly strives to improve its products, so we recommend that you update your TV software whenever an update becomes available. Please visit the website at www.philips.com/support to find out whether there are updates available.

Restoring the factory setup

You can restore your TV's default picture and sound setup. Saved channel setup will not be affected.

- 1 Press **⏠ (Home)** and select Setup to enter the setup menu.
- 2 Press to **▲▼◀▶** Select **[Settings]** > **[Reset]**.
- 3 Select **[Confirm]** and press **OK**. If you want to cancel, please select **[Cancel]** and press **OK**.

6 Setting up channels

This chapter explains how to reconfigure and fine-tune channels.

Setting up channels automatically

Automatically finds and saves channels.

- 1 Press **Home** and select Setup to enter the setup menu.
- 2 Press **▲▼◀▶** Select [TV] > [Channels] > [Channel Scan].
- 3 Press **OK**.
↳ The TV will automatically start searching for channels.

Setting channels manually

You can manually find and save analog TV channels.

Finding and saving new TV channels

- 1 Press **Home** and select Setup to enter the setup menu.
- 2 Press to **▲▼◀▶** Select [TV] > [Channels] > [Manual Search].
↳ Show [Manual Search] menu.
- 3 Select (Search) and use the number keys to enter the frequency.
- 4 Select (Search) and press the **◀▶** key to begin channel search.
- 5 Press **Home** Exit.

Deleting channels

- 1 Press **Home** and select Setup to enter the setup menu.
- 2 Press **▲▼◀▶** Select [TV] > [Channels] > [Channel Edit].
↳ The [Channel Edit] menu will be displayed.
- 3 Press **▲▼** Select the channel you wish to delete, then press the **red button**.

Skipping channels

- 1 Press **Home** and select Setup to enter the setup menu.
- 2 Press **▲▼◀▶** Select [TV] > [Channels] > [Channel Edit].
↳ The [Channel Edit] menu will be displayed.
- 3 Press **▲▼** Select the channel you wish to skip, then press the **blue button**.

Renaming channels

You can rename channels. Selecting a channel will display its name.

- 1 Press **Home** and select Setup to enter the setup menu.
- 2 Press **▲▼◀▶** Select [TV] > [Channels] > [Channel Edit].
↳ The [Channel Edit] menu will be displayed.
- 3 Press **▲▼** to select the channel to be renamed, then press the green button.
- 4 Press **▲▼◀▶** to select characters.
- 5 Press the green button to finish renaming the channel.



Tip

- Channel names can include a maximum of 6 characters.

7 TV connections

This chapter explains how to connect devices with different interfaces.

Note

- You can use different connection types to connect devices to the TV.

Rear connections

① Component signal input

Audio and video input from DVD players, game consoles and other analog or digital devices

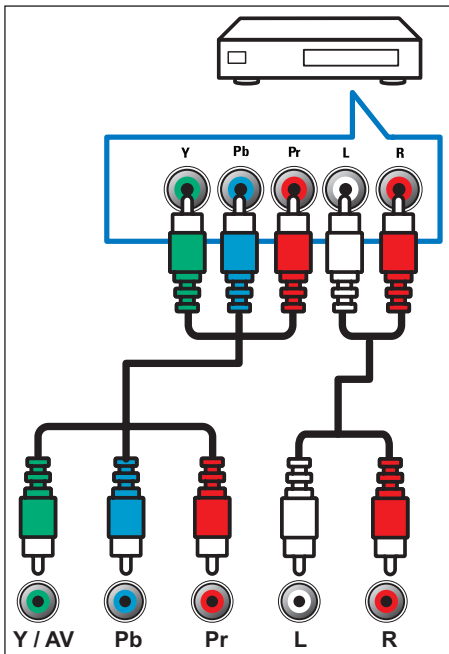

② AV input

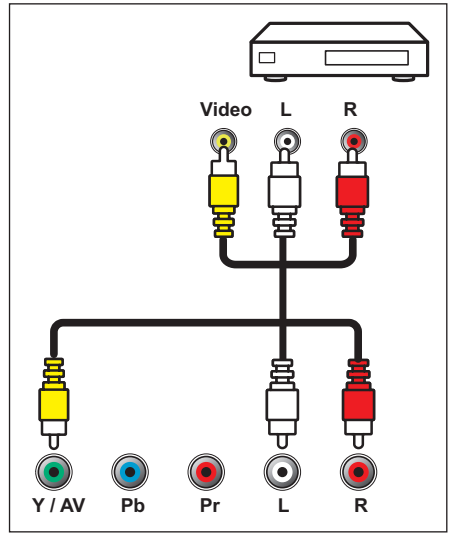

③ Antenna/ cable TV

Input for an antenna, cable or satellite signal.

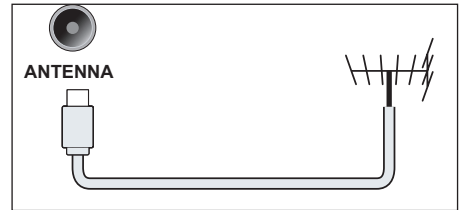

④ PC inputs (VGA and audio)

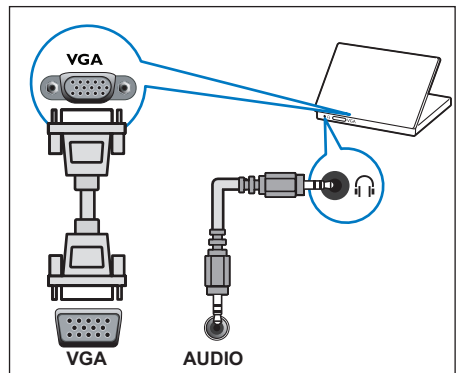

⑤ SPDIF

Transmit sound to digital audio signal, then connected audio device can play digital audio sound.

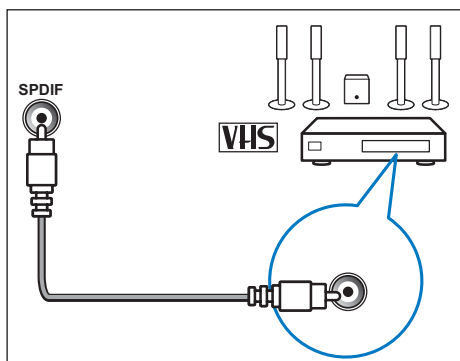

- ⑥ **Headphones** 
Stereo sound output for headphones.

 **Note**

- The TV speakers will automatically be muted when headphones are plugged in.
- The earphone jack is only used as a low-power audio output. Please do not connect high-power devices that are AC-powered (e.g., AC-powered, high-power speakers, etc.).

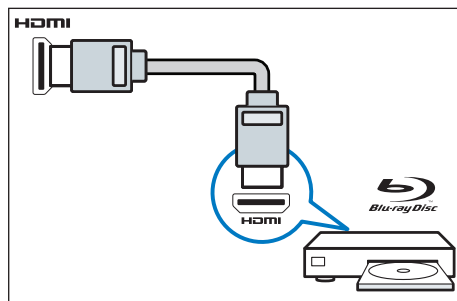

 **Note**

- MHL is unable to support 100% of all mobile devices.

- ② **USB**
Data input from a USB storage device.

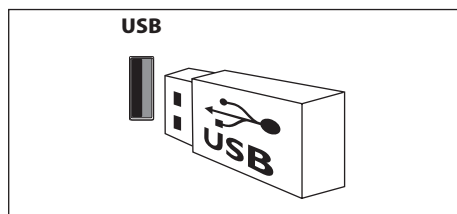

Side connections

- ① **HDMI 1 (ARC) / HDMI 2 (MHL) / HDMI 3**
Digital audio and video input from Blu-ray players and other high definition devices

Connecting to a computer

Before connecting the computer to the TV:

- Set the computer screen refresh rate to 60Hz.
- Select a supported resolution on the computer.

Connect to the computer using one of the following connections:

Notes

- A separate audio cable is required when connecting with DVI or VGA.

- HDMI cable

1 Set the computer display resolution to 480p/576p/720p/1080p

2 Press **Home** and select Setup to enter the setup menu.

3 Press **▲▼◀▶** to select **[Settings]** > **(HDMI Mode)** and set the HDMI Screen Mode to PC or video.

4 Adjust picture format for the best display effect.

- Press **Home** and select Setup to enter the setup menu.
- Press **▲▼◀▶** Select **[Settings]** > **[Picture Format]**.
- Select a picture format.
- Press OK to confirm.

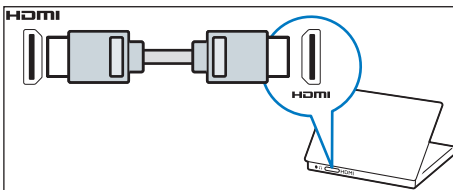

- DVI-HDMI cable

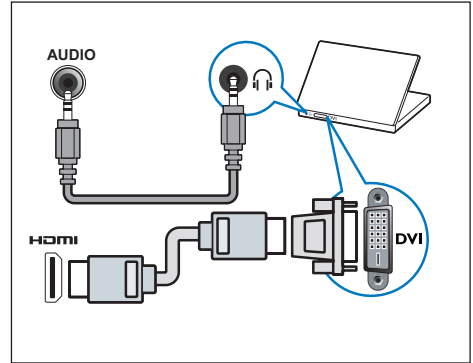

- HDMI cable and HDMI-DVI adapter

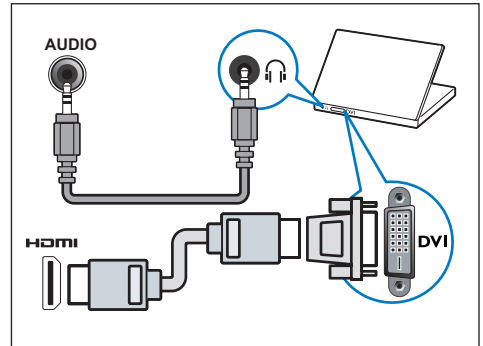

- VGA cable

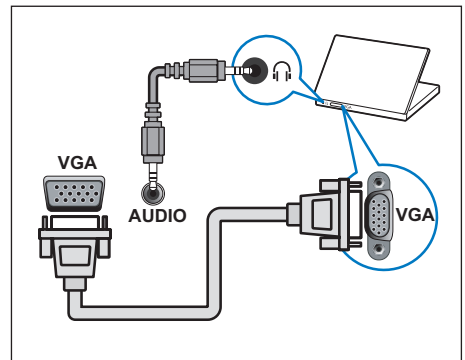

Use Philips EasyLink

Make full use of your Philips EasyLink HDMI-CEC-compatible device to improve the control features and obtain the maximum benefit. HDMI-CEC-compatible devices connected with an HDMI connection can be controlled using the TV remote control.

If you want to turn Philips EasyLink on, you must:

- Connect two or more HDMI-CEC-compatible devices using HDMI connections.
- Confirm that each HDMI-CEC-compatible device is operating normally.
- Switch to EasyLink.

Notes

- The EasyLink-compatible devices must be switched on and selected as signal sources.
- Philips does not guarantee 100% interoperability with all HDMI CEC devices.

Turning EasyLink on or off

Once an HDMI-CEC-compatible device is turned on, the TV will automatically turn on and switch to the correct signal source.

Notes

- If you do not want to use Philips EasyLink, please do not turn this function on.

- 1 Press **⏠ (Home)** and select Setup to enter the setup menu.
- 2 Press **▲▼◀▶** Select **[EasyLink]**.
- 3 Select **[Off]** or **[On]**, then press **OK**.

Using Quick Play

- 1 After enabling EasyLink, press play on the device.
 - ↳ The TV will automatically switch to the correct signal source.

Using Quick Standby

- 1 Press **(Standby — On)** on the remote control.
 - ↳ The TV and all connected HDMI devices will automatically switch to standby mode.

8 Product information

Product information is subject to change without notice. For detailed product information, please visit www.philips.com/support.

Display resolutions

Computer Formats

- Resolution - refresh rate:
 - 640 × 480 - 60Hz
 - 800 × 600 - 60Hz
 - 1024 × 768 - 60Hz
 - 1360 × 768 - 60Hz
 - 1920 × 1080 - 60Hz

Video Formats

- Resolution - refresh rate:
 - 480i - 60Hz
 - 480p - 60Hz
 - 576i - 50Hz
 - 576p - 50Hz
 - 720p - 50Hz, 60Hz
 - 1080i - 50Hz, 60Hz
 - 1080p - 50Hz, 60Hz.

Multimedia

- Supported storage device: USB (only FAT or FAT 32 USB storage devices are supported.)
- Compatible multimedia file formats:
 - Image: JPEG
 - Audio: MP3
 - Video: MPEG 2/MPEG 4 , H.264
 - Document: TXT

Audio Output Power

- 40PFA4500: 8W × 2
- 50PFA4500: 8W × 2
- 55PFA4500: 8W × 2

Inherent resolution

- 40PFA4500: 1920 × 1080
- 50PFA4500: 1920 × 1080
- 55PFA4500: 1920 × 1080

Tuner / Reception / Transmission

- Aerial input: 75ohm coaxial (IEC75)
- TV system: NTSC, SECAM, PAL
- Video playback: NTSC, SECAM, PAL

Remote Control

- Batteries: 2 × AAA (R03 type)

Power Supply

- Mains power: 110-240V, 50-60Hz
- Standby power: ≤ 0.5 W
- Ambient temperature: 5 to 40 degrees Celsius
- Power consumption:
 - 40PFA4500: 80W
 - 50PFA4500: 120W
 - 55PFA4500: 140W

Supported TV mounts

To mount the TV, please purchase a Philips TV mount or any TV mount compliant with the VESA standard. To prevent damage to cables and connectors, be sure to leave a clearance gap of at least 2.2 inches or 5.5cm between the back of the TV to the wall.



Warning

- Please follow all instructions provided with the TV mount. TP Vision Europe B.V. bears no responsibility for improper TV mounting that results in accident, injury or damage.

Model No.	Required Pixel Pitch (mm)	Required Mounting Screws
40PFA4500	200 × 200	4 × M4 (Recommended length: 16 mm)
50PFA4500	400 × 200	4 × M6 (Recommended length: 16 mm)
55PFA4500	400 × 200	4 × M6 (Recommended length: 20 mm)

9 Troubleshooting

This section covers common problems and their accompanying solutions.

General issues

The TV cannot be switched on:

- Disconnect the power cable from the power outlet. Wait for one minute before reconnecting it.
- Check that the power cable is securely connected.

The remote control is not working properly:

- Check that the remote control batteries are correctly inserted according to the +/- orientation.
- Replace the remote control batteries if they are flat or weak.
- Clean the remote control and TV sensor lens.

The standby light on the TV is red and blinking:

- Disconnect the power cable from the power outlet. Wait for the TV to cool down before reconnecting the power cable. If the light continues to blink, please contact Philips Customer Care Centre.

You forgot the code to unlock the TV lock feature

- Enter '3448'.

The TV menu is in the wrong language.

- Change the TV menu to your preferred language.

When turning the TV On/Off or to Standby, you hear a creaking sound from the TV chassis:

- No action is required. The creaking sound comes from the normal expansion and contraction of the TV as it cools down

and warms up. This does not impact its performance.

Channel issues

Previously installed channels do not appear in the channel list:

- Check that the correct channel list is selected.

Picture issues

The TV is on, but there is no picture:

- Check that the antenna is properly connected to the TV.
- Check that the correct device is selected as the TV source.

There is sound but no picture:

- Check that the picture settings are correctly set.

Poor TV reception from the antenna connection:

- Check that the antenna is properly connected to the TV.
- Loudspeakers, unearthed audio devices, neon lights, high buildings and other large objects can influence reception quality. If possible, try to improve the reception quality by changing the antenna direction or moving devices away from the TV.
- If the reception on one particular channel is poor, please fine tune this channel.

There is poor picture quality from connected devices:

- Check that the devices are connected properly.
- Check that the picture settings are correctly set.

The TV did not save your picture settings:

- Check that the TV location is set to the home setting. This mode offers you the flexibility to change and save settings.

The picture does not fit the screen; it is too big or too small:

- Try using a different picture format.

The picture position is incorrect:

- Picture signals from some devices may not fit the screen correctly. Please check the signal output of the device.

Sound issues

The pictures are showing but sound quality is poor:

Note

- If no audio signal is detected, the TV automatically switches the audio output off - this does not indicate malfunction.

- Check that all cables are properly connected.
- Check that the volume is not set to 0.
- Check that the sound is not muted.
- Check that the sound settings are correctly set.

The pictures are showing but sound comes from one speaker only:

- Verify that sound balance is set to the centre.

HDMI connection issues

There are problems with HDMI devices:

- Please note that HDCP (High-bandwidth Digital Content Protection) support can delay the time taken for a TV to display content from a HDMI device.
- If the TV does not recognise the HDMI device and no picture is displayed, please try switching the signal source to another device before switching it back again.
- If there are intermittent sound disruptions, please check that output settings from the HDMI device are correct.
- If you are using a HDMI to DVI adapter or cable, please check if the audio cable that comes with the product is connected to AUDIO (only for mini jacks).

Computer connection issues

The computer display on the TV is not stable:

- Check that your PC uses the supported resolution and refresh rate.
- Set the TV picture format to unscaled.

Contact us

If you cannot resolve your problem, please refer to the FAQs for this model at www.philips.com/support.

If the problem remains unresolved, please contact your local Philips Customer Service Centre.



Warning

- Do not attempt to repair the TV yourself. This may cause severe injury, irreparable damage to your TV or void your warranty.



Note

- Please make a note of your TV model and serial number before you contact Philips Customer Service Centre. These numbers are printed on the back/bottom of the TV and on the packaging.



This electrical and electronic product contains some hazardous substances. You may be safe to use it during the environment-friendly use period, and please hand it over to recycle system after environment-friendly use period exceeded.

Suggestive description of the Recycling Administrative Regulations for Waste Electrical and Electronics Products

In order to care and protect the Earth in a better way, please adhere to the national and applicable laws in relation to the recycling management of waste electrical and electronics products when the user no longer needs to use this product, or when it has reached the end of its product life.

10 Warranty

English
Warranty

Hrvatski
Jamstvo

Polski
Gwarancja

ไทย
การรับประกัน

Български
Гаранция

Italiano
Garanzia

Português
Garantia

Tiếng Việt
Bảo hành

Čeština
Záruka

Indonesia
Jaminan

Română
Garanție

Türkçe
Garanti

Dansk
Garanti

Қазақша
Кепілдік

Русский
Гарантия

Українська
Гарантія

Deutsch
Garantie

Latviešu
Garantija

Slovenščina
Garancija

简体中文
保修

Ελληνικά
Εγγύηση

Lietuvių
Garantija

Slovenský
Záruka

繁體中文
保養

Eesti
Garantii

Magyar
Garancia

Srpski
Garancija

العربية
الضمان

Español
Garantía

Nederlands
Garantie

Suomi
Takuu

Malay
Waranti

Français
Garantie

Norsk
Garanti

Svenska
Garanti

Brazilian Portuguese
Garantia

English - Guarantee

Dear Customer,
Thank you for purchasing this Philips product. For the Philips warranty applicable to this product, we refer you to the Philips website www.philips.com/guarantee. In the event you do not have an internet connection, please contact your local Philips Consumer Care Centre. Contact details are given in the Consumer Care Centres list hereafter.

Български - Гаранция

Уважаеми потребителю,
Благодарим Ви за закупуването на този продукт на Philips. За информация относно гаранцията на Philips, която важи за продукта, посетете сайта на Philips на адрес www.philips.com/guarantee. В случай че не разполагате с връзка с интернет, свържете се с местен център за обслужване на клиенти на Philips. Подробна информация за връзка е предоставена в списъка с центрове за обслужване на клиенти по-долу.

Čeština - Záruka

Vážený zákazník,
děkujeme za koupi toho produktu Philips. Záruku společnosti Philips platnou pro tento produkt naleznete na stránkách společnosti Philips na adrese www.philips.com/guarantee. Pokud nemáte k dispozici internetové připojení, obraťte se na místní středisko zákaznické podpory Philips. Kontaktní údaje jsou uvedeny v seznamu středisek zákaznické podpory níže.

Dansk - Garanti

Kære kunde,
Tak fordi du har købt dette Philips-produkt. For at få mere at vide om den Philipsgaranti, som anvendes til dette produkt, beder vi dig se Philips websted www.philips.com/guarantee. I tilfælde af, at du ikke har en internetforbindelse, bedes du venligst kontakte dit lokale Philips forbrugerservicecenter. Kontakt detaljer oplyses på listen over forbrugerservicesteder herunder:

Deutsch - Garantie

Sehr geehrter Kunde, wir beglückwünschen Sie zu Ihrer Entscheidung für dieses Produkt von Philips. Nähere Informationen zu der für dieses Produkt geltenden Philips Garantie finden Sie im Internet unter www.philips.com/guarantee. Die durch Philips gewährte Garantie beeinträchtigt in keiner Weise Ihre gesetzlichen Rechte. Sofern Sie keinen Zugang zum Internet haben, wenden Sie sich bitte an Ihr Philips Info-Center vor Ort. Die entsprechenden Kontaktdaten entnehmen Sie bitte der nachstehenden Liste.

Ελληνικά - Εγγύηση

Αγαπητέ πελάτη,
Ευχαριστούμε που αγοράσατε αυτό το προϊόν Philips. Για την εγγύηση Philips που καλύπτει το συγκεκριμένο προϊόν, ανατρέξτε στον ιστότοπο της Philips www.philips.com/guarantee. Av

δεν διαθέτετε σύνδεση διαδικτύου, επικοινωνήστε με το τοπικό Κέντρο Εξυπηρέτησης Πελατών της Philips. Στοιχεία επικοινωνίας μπορείτε να βρείτε παρακάτω στον κατάλογο των Κέντρων Εξυπηρέτησης Πελατών.

Eesti - Garantii

Lugupeetud klient,
Täname, et ostsite Philipsi toote. Tootele kehtiva Philipsi garantii leiate Philipsi veebi-saidilt www.philips.com/guarantee. Kui teil puudub Interneti-ühendus, võtke ühendust kohaliku Philipsi klienditeeninduskeskusega. Kontaktid leiate klienditeeninduskeskuste loendist.

Español - Garantía

Estimado cliente:
Le agradecemos la compra de este producto Philips. Para obtener detalles sobre la garantía Philips que se aplica a este producto, visite el sitio web de Philips en www.philips.com/guarantee. Si no tiene conexión a Internet, póngase en contacto con el Centro de atención al cliente de Philips local. Los datos de contacto se indican en la lista de centros de asistencia al cliente a continuación.

Français - Garantie

Cher client,
Merci d'avoir acheté ce produit Philips. Pour connaître les conditions de garantie Philips applicables à ce produit, reportez-vous à la page www.philips.com/guarantee. Si vous ne possédez pas de connexion Internet, contactez votre Service Consommateurs Philips local. Vous trouverez les coordonnées de tous les Services Consommateurs dans la liste ci-après. Ces informations étaient correctes à la date d'impression. Pour des informations à jour, consultez la page www.philips.com/support.

Hrvatski - Jamstvo

Poštovani kupče,
hvala vam što ste kupili ovaj Philipsov proizvod. Philipsovo jamstvo koje se odnosi na ovaj proizvod možete pronaći na Philipsovim internetskim stranicama www.philips.com/guarantee. Ako nemate pristup internetu, obratite se lokalnom Philipsovom Centru za korisnike. U nastavku se nalazi popis Centara za korisnike s podacima za kontakt.

Italiano - Garanzia

Gentile cliente,
grazie per aver acquistato questo prodotto Philips. Per informazioni sulla garanzia Philips applicabile a questo prodotto, è possibile fare riferimento al sito Web Philips www.philips.com/guarantee. Nel caso non disponesse di una connessione Internet, contatti il centro per il servizio clienti Philips locale. È possibile trovare le informazioni di contatto nell'elenco dei centri per il servizio clienti riportato di seguito.

Indonesia - Jaminan

Pelanggan yang terhormat,
Terima kasih telah membeli produk Philips. Untuk mendapatkan jaminan produk ini, kunjungi situs Web Philips di www.philips.com/guarantee. Jika Anda tidak memiliki sambungan Internet, hubungi Pusat Layanan Pelanggan Philips setempat. Rincian kontak tercantum dalam daftar Pusat Layanan Pelanggan.

Казакша - Кеңілдік

Құрметті, Тұтынушы
Мына Philips бұйымын сатып алғаныңызға алғысымызды білдіреміз. Бұл бұйымға қатысты Philips кеңілдігін алу үшін Philips компаниясының www.philips.com/guarantee веб-сайтын қараңыз. Интернетке қосыла алмаған жағдайда, жергілікті Philips тұтынушыларды қолдау орталығына хабарласыңыз. Байланыс мәліметтері осы құжаттың «Тұтынушыларды қолдау орталықтары» тізімінде берілген.

Latviešu - Garantija

Cien klient!
Pateicamies, ka iegādājāties šo Philips produktu. Lai skatītu šī produkta Philips garantiju, apmeklējiet Philips vietni www.philips.com/guarantee. Ja jums nav pieejams internets, lūdzu, sazinieties ar vietējo Philips klientu apkalpošanas centru. Kontaktainformācija ir pieejama tālāk norādītajā klientu apkalpošanas centru sarakstā.

Lietuvių - Garantija

Gerb. kliente,
dėkojame, kad įsigijote „Philips“ gaminį. Jei norite sužinoti, kokia garantija taikoma šiam gaminiui, apsilankykite „Philips“ svetainėje www.philips.com/guarantee. Jei neturite interneto ryšio, susisiekite su vietos „Philips“ klientų aptarnavimo centru. Kontaktinę informaciją rasite toliau pateiktame klientų aptarnavimo centrų sąrašė.

Magyar - Garancia

Kedves Vásárlónk!
Köszönjük, hogy ezt a Philips termékét vásárolta. A Philips termékére vonatkozó garanciáról a Philips webhelyén tájékozódhat: www.philips.com/guarantee. Ha nem rendelkezik internetkapcsolattal, forduljon a Philips helyi ügyfélszolgálatához. A kapcsolattartási adatokat az ügyfélszolgálatok listája tartalmazza az alábbiakban.

Nederlands - Garantie

Beste klant,
hartelijk bedankt voor uw aankoop van dit Philips-product. Voor informatie over de Philips-garantie die van toepassing is op dit product verwijzen wij u naar de Philips-website www.philips.com/guarantee. Hebt u geen internetverbinding, dan kunt u contact opnemen met uw lokale Philips Consumer Care Centre. Contactgegevens vindt u in de lijst met Consumer Care Centres.

Norsk - Garanti

Kjære kunde,
tak for at du kjøpte dette Philips-produktet. Se vårt webområde www.philips.com/guarantee for garantien som gjelder for dette produktet. Hvis du ikke har tilgang til Internett, kan du kontakte ditt lokale Philips-brukerstøttesenter. Du finner kontaktinformasjon i listen over brukerstøttesentre.

Polski - Gwarancja

Szanowni Kliencie!
Dziękujemy za nabycie tego produktu Philips. Aby sprawdzić gwarancję Philips mającą zastosowanie do tego produktu należy przejść do witryny internetowej firmy Philips pod adresem www.philips.com/guarantee. W przypadku nieposiadania łącza internetowego należy skontaktować się z lokalnym Centrum Obsługi Klienta firmy Philips. Informacje kontaktowe znajdują się na liście Centrum Obsługi Klienta.

Português - Garantia

Caro(a) Cliente,
Obrigado por adquirir este produto da Philips. Para obter a garantia da Philips aplicável a este produto, consulte o Web site da Philips www.philips.com/guarantee. Caso não tenha uma ligação à Internet, contacte o Centro de Assistência ao Cliente da Philips local. Os detalhes de contacto são fornecidos na lista de Centros de Assistência ao Cliente indicados a seguir.

Română - Garanție

Stimate client,
Vă mulțumim pentru că ați achiziționat un produs Philips. Pentru garanția Philips aplicabilă acestui produs, vă îndrumăm către site-ul Philips www.philips.com/guarantee. În cazul în care nu dispuneți de o conexiune la Internet, vă rugăm să contactați Centrul local Philips de asistență pentru consumatori. Datele de contact ale Centrelor de asistență pentru consumatori sunt disponibile în lista următoare.

Русский - Гарантия

Уважаемый потребитель!
Благодарим за покупку продукта Philips. Гарантия Philips для этого продукта опубликована на веб-сайте Philips: www.philips.com/guarantee. Если подключения к Интернету нет, обратитесь в местный центр поддержки потребителей Philips. Контактные данные приведены ниже в списке центров поддержки потребителей.

Slovenščina - Garancija

Spoštovani kupci!
Zahvaljujemo se vam za nakup Philipsovega izdelka. Informacije o Philipsovem jamstvu, veljavnem za ta izdelek, najdete na spletnem mestu www.philips.com/guarantee. Če nimate internetne povezave, se obrnite na krajevni Philipsov center za pomoč strankam. Podatki za stik so navedeni v

seznamu Philipsovih centrov za pomoč strankam v nadaljevanju.

Slovenský - Záruka

Vážení zákazníci,
ďakujeme, že ste si kúpili produkt spoločnosti Philips. Ak si chcete pozrieť záručné podmienky vzťahujúce sa na tento produkt, odporúčame Vám navštíviť stránku www.philips.com/guarantee. V prípade, že nemáte prístup k internetu, obráťte sa na miestne centrum podpory zákazníkov spoločnosti Philips. Kontaktné informácie nájdete v ďalej uvedenom zozname centier starostlivosti o zákazníkov.

Srpski - Garancija

Poštovani kupci!
Zahvaljujemo Vam na kupovini ovog Philipsovog proizvoda. Garanciju kompanije Philips koja se odnosi na ovaj proizvod možete pogledati na Philipsovoj Internet prezentaciji, na lokaciji www.philips.com/guarantee. Ukoliko ne posedujete vezu sa Internetom, molimo Vas da se obratite najbližem centru kompanije Philips za brigu o potrošačima. Detaljni podaci o kontaktu dati su u spisku centara za brigu o potrošačima.

Suomi - Takuu

Hyvä asiakas,
Kiitos, että ostit tämän Philips-tuotteen. Tuotetta koskevaan Philipsin takuuseen voit tutustua Philipsin sivustossa osoitteessa www.philips.com/guarantee. Jos sinulla ei ole Internet-yhteyttä, pyydämme sinua ottamaan yhteyttä Philipsin paikalliseen asiakaspalvelukeskukseen. Yhteystiedot ovat jäljempänä olevassa asiakaspalvelukeskusten luettelossa.

Svenska - Garanti

Bästa kund,
Tack för att du har köpt den här Philips-produkten. Besök Philips webbplats www.philips.com/guarantee för information om den garanti som gäller för den här produkten. Om du inte har någon internetuppkoppling kan du kontakta din närmaste Philips-kundtjänst. Kontaktinformation finns i listan över kundtjänster nedan.

Türkçe - Garantisi

Değerli Müşterimiz,
Bu Philips ürününü satın aldığınız için teşekkür ederiz. Bu ürünün sahip olduğunuz Philips garantisi hakkında bilgi almak için www.philips.com/guarantee adresinden Philips web sitesini ziyaret etmenizi öneririz. İnternet bağlantınız yoksa, lütfen yerel Philips Tüketici İlişkileri Merkezi ile iletişime geçin. İletişim bilgileri, Tüketici İlişkileri Merkezleri listesinde verilmştir.

Українська - Гарантія

Шановний покупець,
дякуємо за придбання цього виробу Philips. Гарантію Philips для цього виробу можна знайти на веб-сайті Philips за адресою www.philips.com/

guarantee. Якщо доступ до Інтернет відсутній, зверніться до місцевого центру обслуговування споживачів Philips. Контактна інформація наведена далі у списку центрів обслуговування споживачів.

ไทย - การรับประกัน

เรียนลูกค้า
ขอขอบคุณที่เลือกซื้อผลิตภัณฑ์ของ Philips สำหรับการรับประกันที่มีผลบังคับใช้กับผลิตภัณฑ์นี้ โปรดอ้างอิงเว็บไซต์ของ Philips www.philips.com/guarantee ในการนี้ที่คุณไม่มีอินเทอร์เน็ต โปรดติดต่อศูนย์บริการลูกค้า Philips ประจำท้องถิ่นของคุณ รายละเอียดการติดต่อจะแสดงอยู่ในรายชื่อศูนย์บริการลูกค้าต่อไป

Tiếng Việt - Bảo hành

Kính gửi Quý khách hàng,
Cảm ơn quý vị đã mua sản phẩm Philips này. Để biết bảo hành của Philips có thể áp dụng cho sản phẩm này, chúng tôi xin giới thiệu trang web của Philips www.philips.com/guarantee. Trong trường hợp quý vị không có kết nối internet, vui lòng liên hệ với Trung tâm Chăm sóc Khách hàng của Philips tại địa phương. Chi tiết liên hệ được cung cấp trong danh sách Trung tâm Chăm sóc Khách hàng sau đây.

简体中文 - 保证

尊敬的客户：
感谢您购买此 Philips 产品。有关适用于此产品的 Philips 保修信息，建议您访问 Philips 网站：www.philips.com/guarantee。如果您无法访问 Internet，请联系您当地的 Philips 客户服务中心。将来，我们会在客户服务中心列表中提供详细联系信息。

繁體中文 - 保證

親愛的客戶，您好：
多謝您購買本飛利浦產品。有關適用於本產品的飛利浦保養詳情，請瀏覽飛利浦網站：www.philips.com/guarantee。如您未能連線至互聯網，請與您當地的飛利浦消費者保養中心聯絡。聯絡詳情已詳列於之後的消費者保養中心清單中。

العربية الضمان

عزيزي العميل،
شكراً لكم على شراء هذا المنتج من Philips. لمعرفة شروط ضمان Philips الذي ينطبق على هذا المنتج، راجع موقع www.philips.com/guarantee في حال لم يكن لديك اتصالاً بالإنترنت، يرجى الاتصال برقم مركز خدمة العملاء المحلي لشركة Philips. يمكن معرفة تفاصيل الاتصال من قائمة مراكز خدمة العملاء فيما يلي.

Inggeris-Jaminan

Pelanggan yang dihormati,
Terima kasih kerana membeli produk Philips. Bagi waranti Philips yang terpakai untuk produk ini, kami merujuk anda kepada laman web Philips www.philips.com/guarantee. Sekiranya anda tidak mempunyai sambungan Internet, sila hubungi Pusat Layanan Pelanggan Philips tempatan anda. Butiran kenalan diberikan dalam senarai Pusat Layanan Pelanggan selepas ini.

Português do Brasil

Caro cliente,
Obrigado por ter adquirido este produto Philips. Para obter a garantia Philips aplicável a este produto, consulte o site da Philips www.philips.com/guarantee. Caso você não tenha uma conexão de Internet, entre em contato com a Central de Atendimento ao Cliente Philips. Os detalhes de contato estão disponíveis na lista de Centrais de Atendimento ao Cliente a seguir.



User Manual



FAQ



Chat



Forum



Call



Email



Warranty

www.philips.com/support

България
Грижа за клиента
02 4916 273
(Национален номер)

België/Belgique
Klantenservice/
Service Consommateurs
02 700 72 62
(0.15€/min.)

Bosna i Hercegovina
Potpora potrošačima
033 941 251
(Lokalni poziv)

Republika Srbija
Potpora potrošačima
011 321 6840
(Lokalni poziv)

Česká republika
Zákaznická podpora
228 880 895
(Místní tarif)

Danmark
Kundeservice
3525 8314

Deutschland
Kundendienst
069 66 80 10 10
(Zum Festnetztarif ihres
Anbieters)

Ελλάδα
Τμήμα καταναλωτών
2111983028
(Διεθνής κλήση)

Eesti
Klienditugi
668 30 61
(Kohalikud kõned)

España
Atención al consumidor
913 496 582
(0,10€ + 0,08€/min.)

France
Service Consommateurs
01 57 32 40 50
(coût d'un appel local sauf
surcoût éventuel selon
opérateur réseau)

Hrvatska
Potpora potrošačima
01 777 66 01
(Lokalni poziv)

Ireland
Consumer Care
015 24 54 45
(National Call)

Italia
Servizio Consumatori
02 452 870 14
(Chiamata nazionale)

Қазақстан Республикасы
байланыс орталығы
810 800 2000 00 04
(стационарлық нөмірлерден
Қазақстан Республикасы
бойынша қоңырау шалу тегін)

Latvija
Klientu atbalsts
6616 32 63
(Vietētais tarifs)

Lietuva
Klientų palaikymo tarnyba
8 521 402 93
(Vietinai tarifais)

Luxembourg
Service Consommateurs
2487 11 00
(Appel national)/(Nation-
ale Ruf)

Magyarország
Ügyfélszolgálat
(061) 700 81 51
(Belföldi hívás)

Nederland
Klantenservice
0900 202 08 71
(0,10€/min.)

Norge
Forbrukerstøtte
22 97 19 14

Österreich
Kundendienst
49 34 02 30 53 47
(0,145€/Min.)

Республика Беларусь
Контакт Центр
8 10 (800) 2000 00 04
(бесплатный звонок по
Республике
Беларусь со стационарных
номеров)

Российская Федерация
Контакт Центр
8 (800) 220 00 04
(бесплатный звонок по
России)

Polska
Wsparcie Klienta
22 397 15 04
(Połączenie lokalne)

Portugal
Assistência a clientes
800 780 068
(0,12€/min. – Móvel
0,30€/min.)

România
Serviciul Clienti
031 630 00 42
(Tarif local)

Schweiz/Suisse/Svizzera
Kundendienst/
Service Consommateurs/-
Servizio Consumatori
0848 000 291
(0,081 CHF/Min)

Slovenija
Skrb za potrošnike
01 888 83 12
(Lokalni klic)

Slovensko
Zákaznická podpora
02 332 154 93
(vnútroštátny hovor)

Suomi
Finland Kuluttajapalvelu
09 88 62 50 40

Sverige
Kundtjänst
08 57 92 90 96

Türkiye
Tüketici Hizmetleri
0 850 222 44 66

Україна
Служба підтримки
споживачів
0-800-500-480
(дзвінки зі стаціонарних
телефонів безкоштовні)

United Kingdom
Consumer Care
020 79 49 03 19
(5p/min BT landline)

Argentina
Consumer Care
0800 444 77 49
- Buenos Aires
0810 444 77 82

Brasil
Suporte ao Consumidor
0800 701 02 45
- São Paulo
29 38 02 45

Middle East and Africa
+971 4 2570007

South Africa
03 5667 8250
(Místní tarif)

Australia
1300 99 88 51

Hong Kong/ 香港
(852)26199639

Korea/ 한국
0661-5003

Malaysia
1800 220 180

Philippines/Pilipinas
(02) 8424970

Singapore/ 新加坡
65-62867333

Taiwan/ 台灣
0800 558 088

Thailand/ ประเทศไทย
02 640 3000

Vietnam/ Việt Nam
1800-1767



All registered and unregistered trademarks are property of their respective owners. Specifications are subject to change without notice. Philips and the Philips' shield emblem are trademarks of Koninklijke Philips N.V. and are used under license from Koninklijke Philips N.V. 2015 © TP Vision Europe B.V. All rights reserved. philips.com