

Register your product and get support at:

www.philips.com/TVsupport

24PHD5565

EN User Manual

PHILIPS

Table of contents

1	Caution	2
----------	----------------	----------

2	Safety and Care	3
	Safety	3
	Screen Care	4

3	Environmental	5
	Energy Label	5
	End of Use	5

4	Overview of your TV	6
	Remote control	6
	Using the remote control	7

5	Using your TV	8
	Switching the TV on or off	8
	Switch channels	8
	Adjust the TV volume	9

6	Use more of your TV	10
	Accessing the TV menu	10
	Changing the picture and sound settings	10
	Function settings	11
	Using the timer	12
	Playing multimedia files from USB devices	13
	Updating the TV software	14
	Restoring factory settings	14

7	Change your TV settings	15
	Setting up channels automatically	15
	Swapping channels	15
	Renaming channels	15
	EPG	15
	Time-shift option	16

8	Connecting your TV	17
	Side ports	17
	Down ports	17
	Connecting to a computer	18
	Using Philips EasyLink	19

9	Product information	20
	Display resolutions	20
	Multimedia	20
	Audio output power	20
	Intrinsic resolution	20
	Tuner/reception/transmission:	20
	Remote control	20
	Power supply	20
	Supported TV mounts	21

10	Troubleshooting	22
	General issues	22
	Channel issues	22
	Picture issues	22
	Sound issues	23
	HDMI connection issues	23
	Computer connection issues	23
	Contact us	23

1 Caution

2020©TP Vision Europe B.V. All rights reserved. Specifications are subject to change without notice. All trademarks are the property of Koninklijke Philips N.V. or their respective owners. TP Vision Europe B.V. reserves the right to change products at any time without being obliged to adjust previously supplied products. The material in this manual is adequate for the intended use of the system. If the product, or its individual modules or procedures, are used for purposes other than those specified herein, their validity and suitability must first be confirmed. TP Vision Europe B.V. warrants that the material itself does not infringe upon any patents from the United States. No further warranty is expressed or implied.

TP Vision Europe B.V. accepts no responsibility for any errors in the content of this document, nor for any issues that arise due to the content of this document. Errors reported to Philips will be rectified and published on the Philips support website as quickly as possible.

Terms of warranty

- Risk of injury, damage to the TV or voided warranty! Never attempt to repair the TV yourself.
- Please only use the TV and accessories as set out by the manufacturer.
- The caution sign printed on the back of the TV indicates the risk of electric shock. Never remove the TV cover. Please contact Philips Customer Support if repairs are needed.
- Operations expressly prohibited in this manual, or any adjustments and assembly steps that are not recommended or authorised in this manual, are not within the scope of the warranty.

Pixel characteristics

This LED product has a high number of colour pixels. Although its proportion of effective pixels is 99.999% or more, black dots or bright points of light (red, green or blue) may appear persistently on the screen. This is a structural

property of the display (within common industry standards), and is not a fault.

Trademarks and Copyrights



®Kensington and Micro Saver are registered US trademarks of ACCO World Corporation with issued registrations and pending applications in other countries and regions throughout the world.



HDMI, the HDMI logo and High-Definition Multimedia Interface are trademarks or registered trademarks of HDMI Licensing LLC in the United States and other countries and regions.



Manufactured under license from Dolby Laboratories. Dolby, Dolby Audio, and the double-D symbol are trademarks of Dolby Laboratories.

All other registered and unregistered trademarks are the property of their respective owners.

2 Safety and Care

Please read and make sure you understand all instructions before using the TV. Damage caused by a failure to follow the instructions is not covered by the warranty.

Safety

Important

Read and understand all instructions before you use the TV. If damage is caused by failure to follow the instructions, the warranty does not apply.

Risk of electric shock or fire

- Never expose the TV to rain or water. Never place liquid containers, such as vases, near the TV. If liquids are spilled on or into the TV, disconnect the TV from the power outlet immediately. Contact Philips TV Consumer Care to have the TV checked before use.
- Never expose the TV, remote control or batteries to excessive heat. Never place them near burning candles, naked flames or other heat sources, including direct sunlight.



- Never insert objects into the ventilation slots or other openings on the TV.
- Never place heavy objects on the power cord.
- Avoid force coming onto power plugs. Loose power plugs can cause arcing or fire. Ensure that no strain is exerted on the power cord when you swivel the TV screen.
- To disconnect the TV from the main power, the power plug of the TV must be disconnected. When disconnecting the power, always pull the power plug, never the cord.

Ensure that you have full access to the power plug, power cord and outlet socket at all times.

- The MAINS plug is used as the disconnect device, it shall remain readily operable.

Risk of damage to the TV

- Two people are required to lift and carry a TV that weighs more than 25 kg or 55 lbs.
- If you mount the TV on a stand, only use the supplied stand. Secure the stand to the TV tightly. Place the TV on a flat, level surface that can support the weight of the TV and the stand.
- When wall mounted, ensure that the wall mount can safely bear the weight of the TV set. TP Vision bears no responsibility for improper wall mounting that results in accident, injury or damage.
- Parts of this product are made of glass. Handle with care to avoid injury or damage.
- Before you connect the TV to the power outlet, ensure that the power voltage matches the value printed on the back of the TV. Never connect the TV to the power outlet if the voltage is different.

Stability hazards

A television set may fall, causing serious personal injury or death. Many injuries, particularly to children, can be avoided by taking simple precautions, such as:

- ALWAYS use cabinets or stands or mounting methods recommended by the manufacturer of the television.
- ALWAYS use furniture that can safely support the television.
- ALWAYS educate children about the dangers of climbing on furniture to reach the television or its controls.
- ALWAYS route cords and cables connected to the television so that they cannot be tripped over, pulled or grabbed.
- NEVER place a television in an unstable location.
- NEVER place the television on tall furniture (for example, cupboards or bookcases) without anchoring both the furniture and television to a suitable support.

- NEVER place the television on cloth or other materials that may be located between the television and supporting furniture.
- NEVER place items that might tempt children to climb, such as toys and remote controls, on the top of the television or furniture on which the television is placed.

If the existing television is going to be retained and relocated, the same considerations as above should be applied.

Risk of swallowing batteries

The remote control may contain coin-type batteries which can easily be swallowed by small children. Keep these batteries out of reach of children at all times.

Risk of overheating

Never install the TV in a confined space. Always leave a space of at least 10 cm or 4 inches around the TV for ventilation. Ensure curtains or other objects never cover the ventilation slots on the TV.

Lightning storms

Disconnect the TV from the power outlet and antenna before lightning storms. During lightning storms, never touch any part of the TV, power cord or antenna cable.

Risk of hearing damage

Avoid using earphones or headphones at high volumes or for prolonged periods of time.

Low temperatures

If the TV is transported in temperatures below 5°C or 41°F, unpack the TV and wait until the TV temperature reaches room temperature before connecting the TV to the power outlet.

Humidity

In rare occasions, depending on temperature and humidity, minor condensation can occur on the inside of the TV glass front (on some models). To prevent this, do not expose the TV to direct sunlight, heat or extreme humidity. If condensation occurs, it will disappear spontaneously while the TV is playing for a few hours.

The condensation moisture will not harm the TV or cause malfunction.

Screen Care

Clean

- Never touch, push, rub or strike the screen with any object.
- Unplug the TV before cleaning.
- Clean the TV and frame with a soft damp cloth and wipe gently. Never use substances such as alcohol, chemicals, or household cleaners on the TV.
- To avoid deformations and color fading, wipe off water drops as quickly as possible.
- Avoid stationary images as much as possible. Stationary images are images that remain on screen for extended periods of time. Stationary images include on screen menus, black bars, time displays, etc. If you must use stationary images, reduce screen contrast and brightness to avoid screen damage.



Note

Static images may cause permanent damage to the TV screen.

- Do not display static images on LCD/TV screens for longer than 2 hours, as this can cause ghosting onscreen. To prevent ghosting, reduce the brightness and contrast of the screen when displaying static images.
- Watching programmes in 4:3 format for extended periods may leave different marks on the left and right of the screen and the border of the image. Therefore, avoid using this mode for prolonged periods.
- Displaying static images from video games and computers for extended periods may cause an afterimage and ghosting due to screen burn. Reduce the screen brightness and contrast accordingly when using the TV in this way.

Any afterimages, ghosting or marks displayed on the TV screen due to the causes mentioned above are not covered by the warranty.

3 Environmental

Please act according to your local rules and do not dispose of your old products with your normal household waste. Correct disposal of your old product helps to prevent potential negative consequences for the environment and human health.

Your product contains batteries covered by the European Directive 2006/66/EC, which cannot be disposed with normal household waste.



Please find out for yourself about the local rules on separate collection of batteries because correct disposal will help to prevent negative consequences for the environment and human health.

Energy Label

The Energy Label informs you of the energy efficiency class of this product. The greener the energy efficiency class is, the less energy it consumes. The label shows the energy efficiency class, the average power consumption of this product in use and the average energy consumption for 1 year. You can also find the power consumption values for this product on the Philips website for your country at www.philips.com/TVsupport.

End of Use

Disposal of your old product and batteries

Your product is designed and manufactured with high quality materials and components, which can be recycled and reused.



When this crossed-out wheeled bin symbol is attached to a product it means that the product is covered by the European Directive 2012/19/EU.



Please inform yourself about the local separate collection system for electrical and electronic products.

4 Overview of your TV

Congratulations on your purchase and welcome to Philips! To fully benefit from the support offered by Philips, please register your TV at www.philips.com/TVsupport.

Control panel

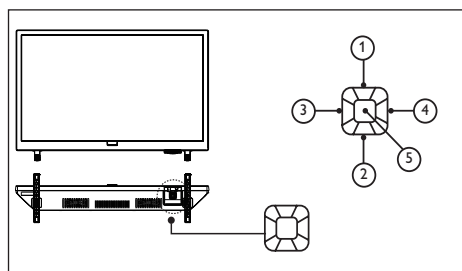

- ① **Volume-**: Without the key menu, the volume-down function is available.
- ② **Volume+**: Without the key menu, the volume-up function is available.
- ③ **Channel-**: When there is no keyboard menu, switch to the prior channel function; when the keyboard menu appears, move up and down the appropriate options.
- ④ **Channel+**: When there is no keyboard menu, switch to the next channel function; when the keyboard menu appears, move up and down the appropriate options.
- ⑤ **Signal source/OK**: In standby, the signal source/OK key is used as a power key. Press this key to boot. After booting, the signal source/OK key is used to open the keyboard menu functions. Note: In USB mode, the signal source/OK key has no function.

Remote control

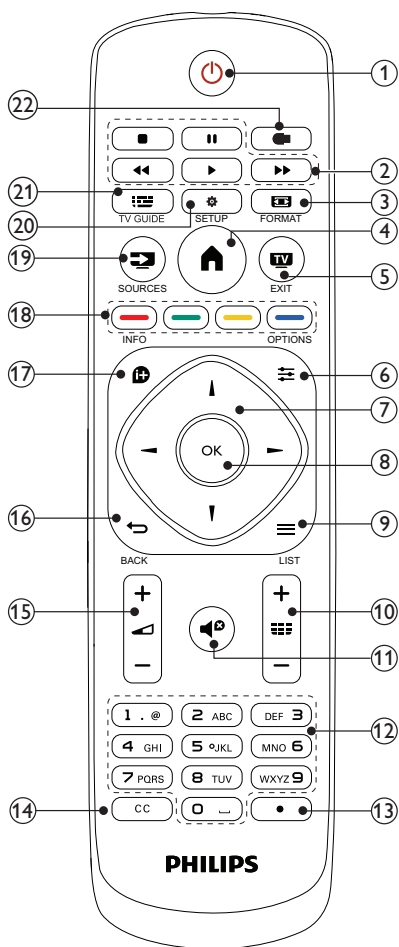

- ① **⏻ (Standby/On)**
Press to turn on/off the TV. The TV is never completely powered off unless it is physically unplugged. Press Power key to exit the factory menu after getting in the factory menu.
- ② **⏮ Playback buttons**
Control playback of multimedia files.
- ③ **📺 FORMAT**

1. Switch screen format.
 2. USB video switch to screen format from video format when in USB mode.
- ④ **🏠 (Home)**
Access or exit from the main menu and return to the previous menu.
 - ⑤ **📺 EXIT**
Exit from menus or TV functions to watch TV.
 - ⑥ **☰ OPTIONS**
In DTV mode, access Options to select audio language.
In USB mode, access Options to select multimedia settings.
 - ⑦ **▲▼◀▶ (Navigation buttons)**
Navigate through menus and select items.
 - ⑧ **OK**
Confirm an entry or selection.
 - ⑨ **☰ LIST**
Press button to active/inactive CH list
 - ⑩ **CH +/- (Channel +/-)**
 1. Press to browse channels.
 2. The channel number should appear on the TV set.
 3. To switch text, picture, video, previous music or next music in USB mode.
 - ⑪ **🔇 (Mute)**
Mute or restore audio.
 - ⑫ **0-9 (Numeric buttons 0-9)**
 1. Press number button to direct access to TV channel.
 2. Press the pass code to activate the factory mode.
 - ⑬ **● (Dot):**
Enter digital sub-channels.
 - ⑭ **CC (Closed captions):**
Switch on or off closed captions in TV mode.
 - ⑮ **VOL +/- (Volume)**
Adjust volume.
 - ⑯ **↶ BACK**
Press to display the previous channel or source.
 - ⑰ **📶 INFO**
Display information about current activity.

- ⑱ **Color buttons**
Select tasks or options. The buttons function according to the services offered by the service provider.
- ⑲ **📡 SOURCES**
Select connected devices
- ⑳ **⚙️ SETUP**
Accesses TV setup menu.
- ㉑ **📺 TV GUIDE**
Accesses or exits the EPG in DTV source.
- ㉒ **📶 USB**
Access USB storage device.

Using the remote control

When you use the remote control, hold it close to the TV and point it at the remote control sensor. Make sure that the line-of-sight between the remote control and TV is not blocked by furniture, walls or other objects.

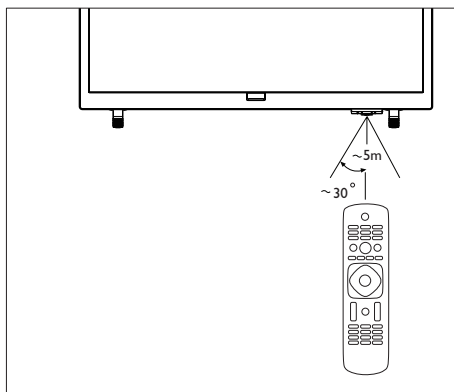

5 Using your TV

This section helps you to perform basic TV operations.

Switching the TV on or off

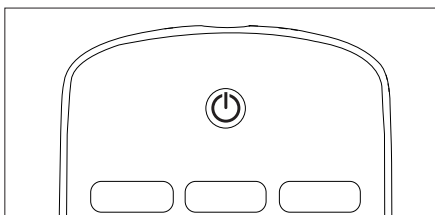
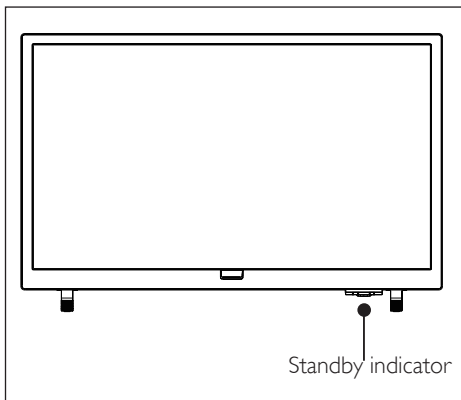

To switch on

- Plug in the power plug.
↳ If the standby indicator is red, press  (**Standby/On**) on the remote control.

To switch to standby

- Press  (**Standby/On**) on the remote control.
↳ The standby indicator switches to red.



- Though your TV consumes very little power when in standby mode, energy continues to be consumed. When not in use for an extended period of time, disconnect the TV power cable from the power outlet.

Switch channels

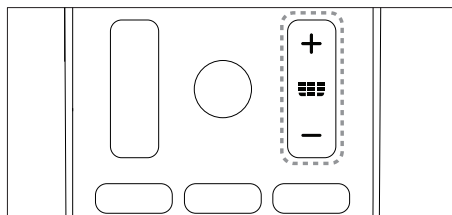
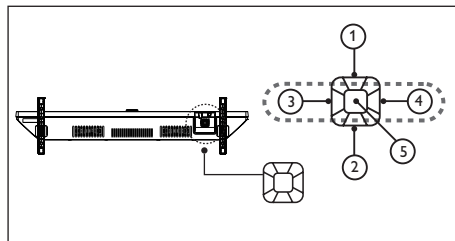

- Press **CH+/-** on the remote control or the lower right section of the TV.
- Enter a channel number using the numeric buttons on the remote control.
- Press  on the remote control to switch and return to the previous channel.

View installed channel

All available channels can be viewed in the channel list.

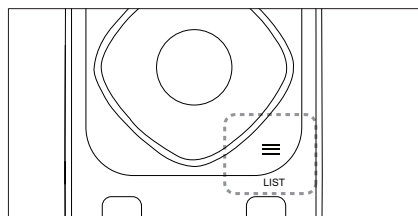

- 1 Press **≡ LIST**.
↳ The channel list appears.
- 2 Press **▲▼** to select channels and to browse the channel list.
- 3 Press **OK** to watch the selected channel.
- 4 Press **↶** to switch and return to the last watched channel.

Watch connected devices

Note

- Switch on the device before selecting it as an external signal source.

Use the Sources button

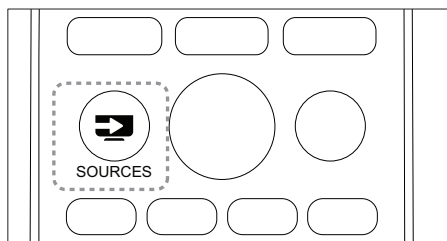

- 1 Press **≡ SOURCES**.
↳ The source list appears.
- 2 Press **▲▼** to select a device.
- 3 Press **OK** to confirm.
↳ The TV switches to the selected device.

Adjust the TV volume

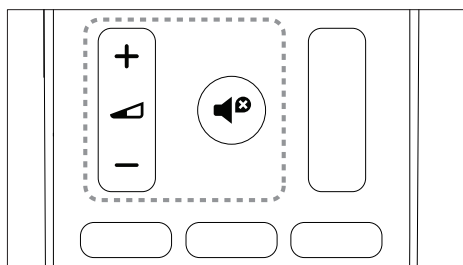
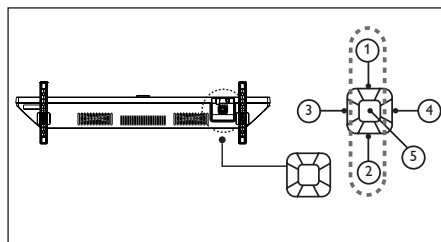

To increase or decrease volume

- Press **Volume control +/-** on the lower right section of the TV or the **VOL +/-** on the remote control.

To mute or unmute sound

- Press **🔇 (Mute)**.
- Press **🔊** again to restore the sound.

6 Use more of your TV

Accessing the TV menu

The menu helps you set up channels, change the picture and sound settings, and access other functions.

- 1 Press **Home** .
↳ The menu screen is displayed.

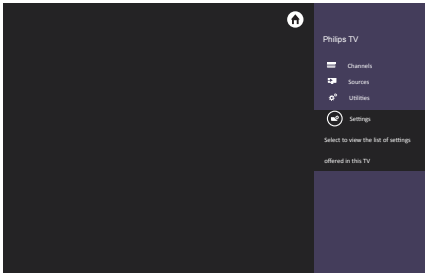

- 2 Select **[Settings]**.
- 3 Press **▲▼◀▶** to select from the following options:
 - **[Picture]** / **[Sound]** / **[TV]** (only shown in TV mode) / **[Settings]** / **[Parental]** (only shown in TV mode) / **[EasyLink]**.
- 4 Press **OK** to confirm.
- 5 Press **Home** to exit or return to the previous menu.

Changing the picture and sound settings

You can change the picture and sound settings to suit your preferences. You can use the preset settings or manually adjust the settings.

Adjusting the picture settings

- 1 Press **Home** and select **[Settings]** to enter the **[Settings]** menu. Then select **[Picture]**.
↳ The **[Picture]** menu is displayed.
- 2 Press **▲▼◀▶** to select/adjust the settings:
 - **[Smart Picture]:**
 - **[Standard]:** standard picture settings. This option is recommended for home entertainment use.
 - **[Vivid]:** increases the contrast and sharpness of the picture.
 - **[Movie]:** applies to film settings and works best in a home cinema environment.
 - **[Natural]:** increases the softness of the picture.
 - **[Personal]:** you can customise your settings with this option.
 - **[Brightness]:** adjusts the intensity and detail of dark areas (the adjustments made can only be saved in personal settings).
 - **[Video Contrast]:** adjusts the intensity and detail of bright areas, while dark areas remain unchanged (the adjustments made can only be saved in personal settings).
 - **[Color]:** adjusts the colour saturation (the adjustments made can only be saved in personal settings).
 - **[Sharpness]:** adjusts the sharpness of the image (the adjustments made can only be saved in personal settings).
 - **[Tint]:** adjusts the level of green (this option only appears when using the NTSC system).
 - **[Color Temperature]:**
 - **[Cool]:** gives a bluish-white hue.
 - **[Normal]:** gives a white hue. Users can customise the white hue when in PC mode.
 - **[Warm]:** gives a reddish-white hue.
 - **[Advance Control]:**
 - **[Noise Reduction]:** filters and eliminates signal noise in the image.
 - **[Backlight]:** adjusts the screen brightness (when the backlight is set to a low value, a brief white flicker may be seen when switching the TV on. This is normal).
 - **[Dynamic Contrast]:** sets the contrast to maximum.
 - **[Dynamic Backlight]:** the contrast changes with the brightness of the image.

Note

- Options may vary for pictures from different sources.

Adjusting the sound settings

- 1 Press **⬆** (Home) and select **[Settings]** to enter the **[Settings]** menu. Select **[Sound]**.
↳ The **[Sound]** menu is displayed.
- 2 Press **▲▼◀▶** to select and adjust the settings:
 - **[Smart Sound]:**
 - **[Standard]:** gives balanced, outstanding sound performance in the treble, mid and bass ranges.
 - **[Music]:** enhances treble and bass, delivering bright, clear, pure sound for piano or orchestral instrument performances.
 - **[Movie]:** enhances film sound effects, allowing you to enjoy a home cinema-like effect.
 - **[Speech]:** enhances the performance of sound ranges associated with the human voice spectrum. This option is suitable for watching news or arts programmes.
 - **[Flat]:** enhances the smoothness of the sound output, creating a softer sound.
 - **[Personal]:** provides users with customisation functions so that all sound effect parameters are optimised to create the best possible experience.
 - **[Balance]:** adjusts the balance of the left and right speakers.
 - **[Bass]:** adjusts the base level (the adjustments made can only be saved in personal settings).
 - **[Treble]:** adjusts the treble level (the adjustments made can only be saved in personal settings).
 - **[Virtual Surround]:** enables virtual surround sound: switching on or off.
 - **[AVL]:** turns automatic volume adjustment on when switching channels.
 - **[SPDIF MODE]:** selects the coaxial output mode.
 - **[Audio Delay]:** delays the sound output.
 - **[TVSpeakers]:** turns sound on the TV on and off.
 - **[Clear Sound]:** turns speech on and off.
 - **[TV Placement]:** adjusts the means of the TV placement.

Function settings

- 1 Press **⬆** (Home) and select **[Settings]** to enter the **[Settings]** menu. Then select **[Settings]**.
↳ The **[Settings]** menu is displayed.
- 2 Press **▲▼◀▶** to select and adjust the settings:
 - **[Menu Language]:** adjusts the language settings of the TV.
 - **[Picture Format]:** the majority of signals use 16:9, 4:3, zoom 1 and zoom 2 formats. HDMI signal sources use 16:9, 4:3, Point to Point, zoom 1 and zoom 2 formats.
 - **[Menu Timeout]:** sets how long the menu is displayed.
 - **[Blue Screen]:** sets the colour of the screen when the TV receives no signal (except TV analog channels).
 - **[Auto Sleep]:** sets how long the TV must be idle for before switching off automatically (not applicable to PC mode).
 - **[Sleep Timer]:** sets when the TV automatically enters standby mode. The options are: off/10/20/30/60/90/180 minutes..
 - **[Time Setup]:** sets the system time.
 - **[Freeze Switch]:** sets the freeze screen for switching analog channels (only available in TV mode).
 - **[Time Zone]:** sets the time zone. Press Down key to enter the second page.
 - **[Color System]:** sets the AV colour system (only displayed in AV mode).
 - **[HDMI Mode]:** sets the HDMI mode (only displayed in 480p/576p/720p/1080p HDMI modes).
 - **[PVR File System]:** before carrying out PVR operations, the USB flash drive must be formatted and memory space allocated.
 - **[Reinstall TV]:** restores all settings to default and reopens the installation wizard menu.
 - **[Reset]:** restores the default settings (excluding password settings and channel information).
 - **[Software Version]:** checks the current software version.

Changing the picture format

- 1 Press **⏠** (Home) and select **[Settings]** to enter the **[Settings]** menu. Then select **[Settings]**.
- 2 Press **▲▼◀▶** to select **[Picture Format]**.
- 3 Select a **picture format**.
- 4 Press **OK** to confirm.

Summary of picture formats

The following picture formats can be configured.

Note

- Some picture settings may be unavailable due to differences between picture signal formats.

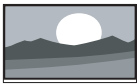

[16:9]: adjusts the normal standard ratio to a widescreen format.



[4:3]: the normal standard format.



[Zoom 1]: horizontal scaling for the widescreen picture format. When this format is used, the left and right of the frame will be partially cut off.



[Zoom 2]: adjusts the standard ratio to a widescreen format (only 16:9, 4:3 and Point to Point options are available in PC mode).



[Point to Point]: used for HDMI connections with PCs. This displays the full PC screen to achieve the best display results.

Using the timer

You can set the timer to switch the TV to standby mode at a set time.

Tip

- Set the sleep timer before using the timer function.

Setting the sleep timer

Tip

- You can turn the TV off in advance or reset the sleep timer when the timer is up.

- 1 Press **⏠** (Home) and select **[Settings]** to enter the **[Settings]** menu. Then select **[Settings]**.
- 2 Press **▲▼◀▶** to select **[Sleep Timer]**.
- 3 Press **▲▼** to select a time for the sleep timer to switch the TV off.
↳ The longest time that the sleep timer can be set for is 180 minutes.

TV lock

By locking the TV remote control, you can prevent children from watching specific programmes or channels.

Setting or changing your password

- 1 Press **⏠** (Home) and select **[Settings]** to enter the **[Settings]** menu. Then select **[Parental]**.
- 2 Enter the password using the numeric buttons on the remote control.
- 3 Select **[Change Password]** and follow the instructions onscreen to change the password.

Locking channels

- 1 Press **⏠** (Home) and select **[Settings]** to enter the **[Settings]** menu. Then select **[Parental]**.

- 2 Enter the password and select **[Parental Rating]**.
- 3 Adjust the channel locking rating.
- 4 Repeat this step to adjust the channel ratings.
 - **[Parental Rating]**: when channels are locked:
 - Enter the four-digit password to access the channel blocking menu.
 - Enter the four-digit password to view locked channels.
 - Enter the four-digit password to access the parental lock menu.
 - **[Clear All]**: this function will clear all previously saved locked channels and signal sources.
 - The default password is '0000'. Users may change or set the password themselves.

Note

- If you go to a locked channel, you will be prompted to enter the password.

Playing multimedia files from USB devices

You can play photo, music or video files stored on a USB storage device on your TV.

- Supported storage devices: USB (only FAT or FAT 32 USB storage devices are supported)
- Supported multimedia file formats:
 - Images: JPEG
 - Audio: MP3
 - Video: MPEG 2/MPEG 4, H.264
 - Documents: TXT

Note

- TPVision assumes no responsibility if a USB storage device is not supported, or if the data on the device is damaged or lost.

Viewing photos and text files and playing audio and video files

- 1 Turn the TV on.
- 2 Connect the USB storage device to the USB port on the side of the TV.
- 3 Press **↵** (**SOURCES**).
- 4 Select **[USB]** and press **OK**.
 - ↳ The USB browser will open.

Viewing photos

- 1 Select the photo within the USB browser and press **OK**. The photo will be enlarged to fill the screen.
 - Press **CH-** or **CH+** to see either the previous or the next photo.

Starting slide shows

- 1 Select a photo or folder and then press **OK**. The photo will be enlarged to fill the screen.
 - ↳ The slide show will start playing from the selected photo.
- 2 Press the following buttons to control the playback of photos:
 - **▶** or **⏸**: play or pause
 - **CH-** or **CH+**: view either the previous or the next photo.

Changing the slide show settings







To start playing a slide show, press **≡** (**Option**) and select one of the following options, then press **OK**.

- **[Rotate]**: sets the images to rotate.
- **[Duration]**: sets the duration of the slide show.







Listening to music

- 1 In the USB browser, select a song or album. Then press **OK** to begin playing.





Changing the music settings

-  or : to play or pause.
- /: switches to the previous/next song.
- /: for rewinding or fast forwarding.

Watching videos

- 1 Select the video file in the USB browser; then press **OK** to play the video.
- 2 The following buttons are used to control the film:
 -  or : to play or pause.
 - /: move to the previous or next one.
 - /: for rewinding or fast forwarding.

Viewing text files

- 1 Select the text file in the USB browser; then press **OK** to view the document.
- 2 The following buttons are used to control the text playback:
 -  or : to play or pause
 - /: to go back 20 pages or move on 20 pages.

Removing USB storage devices

Note

- Follow the steps below to avoid damaging the USB storage device.





- 1 Hold down  to exit the USB browser.
- 2 Wait around 5 minutes before removing the USB storage device.

Updating the TV software

Philips constantly strives to improve its products, and so we recommend that you update your TV software whenever an update is released. Visit www.philips.com/TVsupport to check whether updates are available.

Restoring factory settings

You can restore the default picture and sound settings for your TV without affecting the saved channel set up.

- 1 Press  (**Home**) and select **[Settings]** to enter the **[Settings]** menu
- 2 Press    Then select **[Settings]** > **[Reset]**.
- 3 Select **[Yes]** and press **OK**. If you wish to cancel, select **[No]** and press **OK**.

7 Change your TV settings

This chapter explains how to reconfigure and fine-tune channels.

Setting up channels automatically

This option automatically finds and saves channels.

- 1 Press **⬇** (Home) and select **[Settings]** to enter the **[Settings]** menu
- 2 Press **▲▼◀▶** to select **[TV] > [Channels] > [Channel Scan]**.
- 3 Press **OK**.
↳ The TV will start searching for channels automatically.

Swapping channels

- 1 Press **⬇** (Home) and select **[Settings]** to enter the **[Settings]** menu.
- 2 Press **▲▼◀▶** to select **[TV] > [Channels] > [Channel Edit]**.
↳ The **[Channel Edit]** menu is displayed.
- 3 Press **▲▼** to select **the analogue channel you wish to swap**. Then press the **blue button**.
- 4 Press **▲▼** to select **the analogue channel you wish to swap**. Then press the **blue button** to confirm.

Renaming channels

You can rename channels. Selecting a channel will display its name

- 1 Press **⬇** (Home) and select **[Settings]** to enter the **[Settings]** menu.
- 2 Press **▲▼◀▶** to select **[TV] > [Channels] > [Channel Edit]**.
↳ The **[Channel Edit]** menu is displayed.
- 3 Press **▲▼** to select the analogue channel you wish to rename. Then press the **OK** button.
- 4 Press **▲▼** to select the channel name, then press the **OK** button to enter the editing interface.
- 5 Press **▲▼◀▶** to select the characters.
- 6 Select **[Confirm]** then **OK** to finish renaming the channel.



Tip

- Channel names can be up to six characters long.

EPG



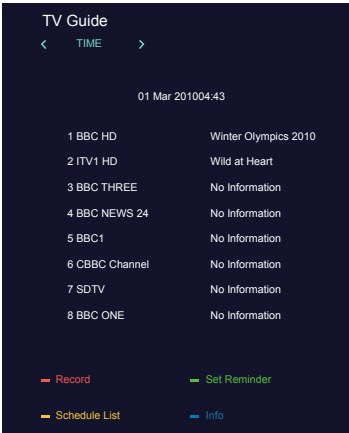

- 1 Press **⚡** (TV GUIDE) on the remote control to access TV program guide list (It is available only in DTV mode). In this program guide list, press **▲▼** to select the current time and date, and then press **◀▶** to view all programs information in the next 7 days of the future (Fig.1).

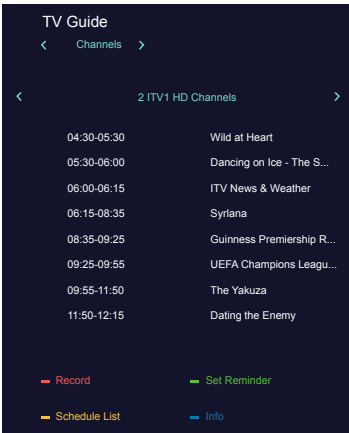







- 2 Press ◀▶ to select Channel in the top bar of guide list, then press ▲▼ to view a program information in the next 7 days of the future. Focus on the Channel bar you can press ◀▶ to view the other programs information (Fig.2).





You can select the color keys to edit these programs with the tips on the screen. The color keys introductions as below:

- **Record:** Press  red key to record the program.
- **Remind:** Press  green key to set remind the program.
- **Info:** Press  blue key to display the program information.
- **Schedule:** Press  yellow key to view program status in schedule list.







Recording options menu introduction

- : Play the current video.
- : Fast back for the video, press  (play) key to play normally.
- : Fast forward for the video, press  (play) key to play normally.
- : Pause the video.
- : Stop recording and quit the recording function.

Time-shift option

In DTV mode, press  (start), time-shift option menu will show on the screen, and the program is in suspended status. press  to stop and quit time-shift function. When you leave program for a short time, time-shift function can suspend and cache the playing program to U disk. When you resume playing, the program can continue to be played.

Time-shift options menu introduction

- : Play the current video.
- : Fast back for the video, press  (play) key to play normally.
- : Fast forward for the video, press  (play) key to play normally.
- : Pause the video.
- : Stop and quit time-shift function.

8 Connecting your TV

This section explains how to connect devices with different connectors.



Note

- You can use different connection types to connect devices to the TV.

Side ports

① USB

Data input from a USB storage device.

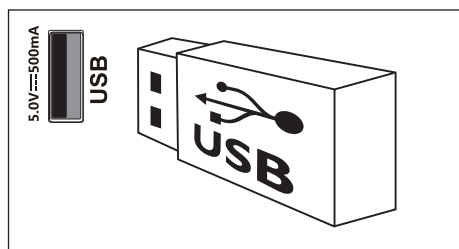

② Headphones

Stereo sound output for headphones.



Note

- Headphones can only be used as a low-power audio output. Do not connect high-power active devices (such as high-power active speakers).

③ Antenna/cable TV

Input for an antenna, cable.



Down ports

① SPDIF OUT

Digital audio signal output for digital audio equipment.

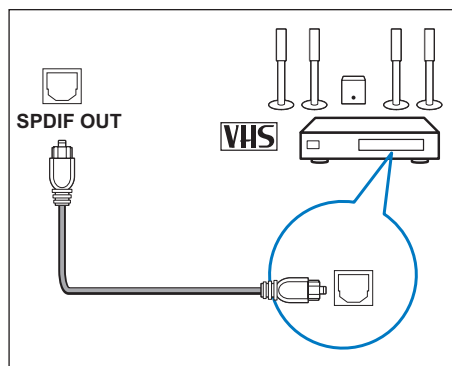

② HDMI 2 (ARC)

Digital audio and video input from high definition devices such as Blu-ray players.

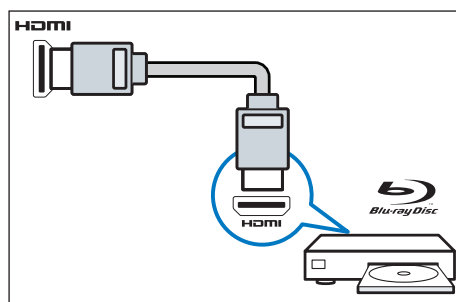

③ HDMI 1

Digital audio and video input from high definition devices such as Blu-ray players.

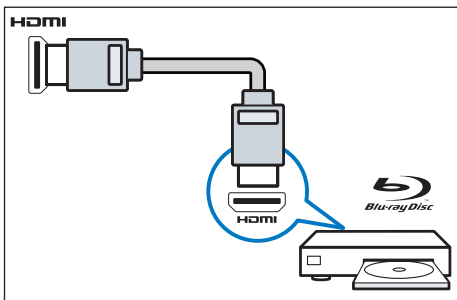

④ AV input

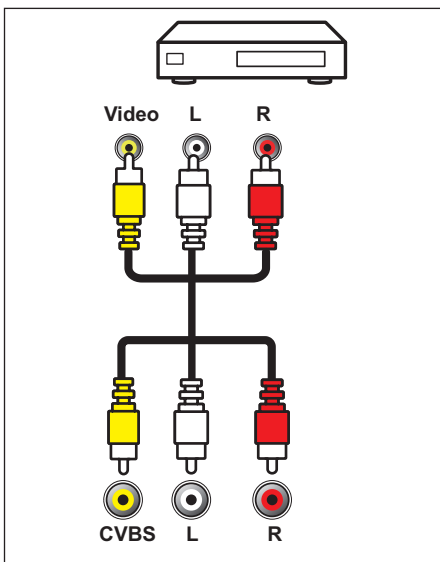

Connecting to a computer

Before connecting a computer to the TV:

- Set the computer screen refresh rate to 60 Hz.
- Select a supported screen resolution on the computer.

Connect to the computer using one of the following connections:

Note

- A separate audio cable is required when connecting via DVI .

- HDMI cable
- 1 Set the resolution of the computer display to 480p/576p/720p/1080p
 - 2 Press **Home** and select **[Settings]** to enter the **[Settings]** menu.
 - 3 Press **▲▼◀▶** to select **[Settings]** > **[HDMI Mode]**, and set the HDMI display mode to graphics or video.
 - 4 Adjust the picture format to achieve the best display results.
 - Press **Home** and select **[Settings]** to enter the **[Settings]** menu.
 - Press **▲▼◀▶** to select **[Settings]** > **[Picture Format]**.
 - Select a picture format.
 - Press **OK** to confirm.

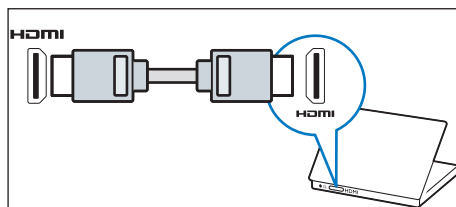

- DVI-HDMI cable

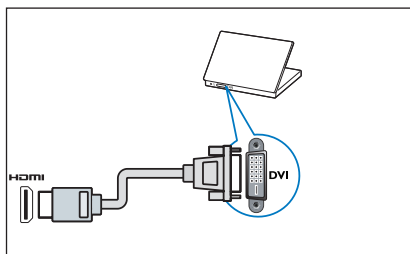

- HDMI cable and HDMI-DVI adapter

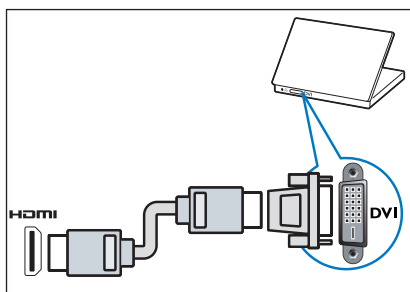

Using Philips EasyLink

Making full use of your Philips EasyLink HDMI-CEC compatible devices can enhance control features to achieve the best possible results. HDMI-CEC compatible devices connected through the HDMI connector can be controlled by a TV remote control.

To enable Philips EasyLink, you will need to:

- Connect two or more HDMI-CEC compatible devices using HDMI connections.
- Make sure that each HDMI-CEC compatible device is operating normally.
- Switch to EasyLink.

Note

- EasyLink compatible devices must be switched on and selected as a signal source.
- Philips does not guarantee 100% interoperability with all HDMI-CEC devices.

Enabling or disabling EasyLink

Once an HDMI-CEC compatible device has been switched on, the TV will automatically turn on and switch to the correct signal source.

Note

- Do not enable this function if you would prefer not to use Philips EasyLink.

- 1 Press **Home** and select **[Settings]** to enter the **[Settings]** menu.
- 2 Press **▲▼◀▶** to select **[EasyLink] > [HDMI CEC]**.
- 3 Select **[Off]** or **[On]**, then press **OK**.

Using One-touch Play

- 1 Once EasyLink has been enabled, press play on the device.
 - ↳ The TV will automatically switch to the correct signal source.

Using One-touch Standby

- 1 Press **(Standby/On)** on the remote control.
 - ↳ The TV and all connected HDMI devices will automatically enter standby mode.

9 Product information

Product information is subject to change without notice. For detailed product information, please visit www.philips.com/TVsupport.

Display resolutions

Computer Formats

- Resolution - refresh rate:
 - 640 x 480 - 60Hz
 - 800 x 600 - 60Hz
 - 1024 x 768 - 60Hz
 - 1360 x 768 - 60Hz
 - 1920 x 1080 - 60Hz

Video Formats

- Resolution - refresh rate:
 - 480i - 60Hz
 - 480p - 60Hz
 - 576i - 50Hz
 - 576p - 50Hz
 - 720p - 50Hz, 60Hz
 - 1080i - 50Hz, 60Hz
 - 1080p - 50Hz, 60Hz.

Multimedia

- Supported storage devices: USB (only FAT or FAT 32 USB storage devices are supported).
- Compatible multimedia file formats:
 - Image: JPEG

- Audio: MP3
- Video: MPEG 2/MPEG 4, H.264
- Document: TXT

Audio output power

- 24PHD5565: 3W x 2

Intrinsic resolution

- 24PHD5565: 1366 x 768

Tuner/reception/transmission:

- Aerial input: 75 ohm coaxial (IEC75)
- TV systems: NTSC-M, PAL-M, PAL-N, ISDB-T
- Video playback: NTSC, PAL

Remote control

- Batteries: 2 x AAA

Power supply

- Mains power: 110-240V, 50-60Hz
- Standby power: ≤ 0.5 W
- Ambient temperature: 5 to 40 degrees Celsius
- Power consumption:
 - 24PHD5565: 36W

Supported TV mounts

To mount the TV, please purchase a Philips TV mount or any TV mount compliant with the VESA standard. To prevent damage to cables and connectors, be sure to leave a clearance gap of at least 2.2 inches (5.5cm) between the back of the TV to the wall.

VESA

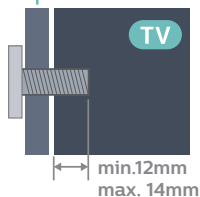

Model No.	Required Pixel Pitch (mm)	Required Mounting Screws
24PHD5565	100 × 200	4 × M4 (Minimum 12 mm, Maximum 14mm)



Caution

- Please follow all instructions provided with the TV mount. TP Vision Europe B.V. bears no responsibility for improper TV mounting that results in accident, injury or damage.

10 Troubleshooting

This section covers common problems and their accompanying solutions.

General issues

The TV cannot be switched on:

- Disconnect the power cable from the power outlet. Wait for one minute before reconnecting it.
- Check that the power cable is securely connected.

The remote control is not working properly:

- Check that the remote control batteries are correctly inserted according to the +/- orientation.
- Replace the remote control batteries if they are flat or weak.
- Clean the remote control and TV sensor lens.

The standby light on the TV is red and blinking:

- Disconnect the power cable from the power outlet. Wait for the TV to cool down before reconnecting the power cable. If the light continues to blink, please contact Philips Customer Care Centre.

You forgot the code to unlock the TV lock feature

- Enter '3448'.

The TV menu is in the wrong language.

- Change the TV menu to your preferred language.

When turning the TV On/Off or to Standby, you hear a creaking sound from the TV chassis:

- No action is required. The creaking sound comes from the normal expansion and contraction of the TV as it cools down and warms up. This does not impact its performance.

Channel issues

Previously installed channels do not appear in the channel list:

- Check that the correct channel list is selected.

Picture issues

The TV is on, but there is no picture:

- Check that the antenna is properly connected to the TV.
- Check that the correct device is selected as the TV source.

There is sound but no picture:

- Check that the picture settings are correctly set.

Poor TV reception from the antenna connection:

- Check that the antenna is properly connected to the TV.
- Loudspeakers, unearthened audio devices, neon lights, high buildings and other large objects can influence reception quality. If possible, try to improve the reception quality by changing the antenna direction or moving devices away from the TV.
- If the reception on one particular channel is poor, please fine tune this channel.

There is poor picture quality from connected devices:

- Check that the devices are connected properly.
- Check that the picture settings are correctly set.

The TV did not save your picture settings:

- Check that the TV location is set to the home setting. This mode offers you the flexibility to change and save settings.

The picture does not fit the screen; it is too big or too small:

- Try using a different picture format.

The picture position is incorrect:

- Picture signals from some devices may not fit the screen correctly. Please check the signal output of the device.

Sound issues

The pictures are showing but sound quality is poor:

Note

- If no audio signal is detected, the TV automatically switches the audio output off - this does not indicate malfunction.
- Check that all cables are properly connected.
- Check that the volume is not set to 0.
- Check that the sound is not muted.
- Check that the sound settings are correctly set.

The pictures are showing but sound comes from one speaker only:

- Verify that sound balance is set to the centre.

HDMI connection issues

There are problems with HDMI devices:

- Please note that HDCP (High-bandwidth Digital Content Protection) support can delay the time taken for a TV to display content from a HDMI device.
- If the TV does not recognise the HDMI device and no picture is displayed, please try switching the signal source to another device before switching it back again.
- If there are intermittent sound disruptions, please check that output settings from the HDMI device are correct.
- If you are using a HDMI to DVI adapter or cable, please check if the audio cable that comes with the product is connected to AUDIO (only for mini jacks).

Computer connection issues

The computer display on the TV is not stable:

- Check that your PC uses the supported resolution and refresh rate.
- Set the TV picture format to unscaled.

Contact us

If you cannot resolve your problem, please refer to the FAQs for this model at www.philips.com/TVsupport.

If the problem remains unresolved, please contact your local Philips Customer Service Centre.



Warning

- Do not attempt to repair the TV yourself. This may cause severe injury, irreparable damage to your TV or void your warranty.



Note

- Please make a note of your TV model and serial number before you contact Philips Customer Service Centre. These numbers are printed on the back/bottom of the TV and on the packaging.



All registered and unregistered trademarks are the property of their respective owners.
Specifications are subject to change without notice.
Philips and the Philips' shield emblem are trademarks of Koninklijke Philips N.V. and are used under license from Koninklijke Philips N.V.
2020 © TP Vision Europe B.V. All rights reserved.
philips.com



X41G24MV813xxA