

IMPORTANT SAFETY INSTRUCTIONS

When using an electric product, basic precautions should always be followed, including the following:

Read all instructions before using this product.

DANGER

To reduce the risk of electric shock:

- Do not reach for a corded product that has fallen into water. Unplug immediately from the power outlet.
- Keep the power cord dry.



- Do not place or store the product where it can fall or be pulled into a tub or sink. Do not place or drop the product into water or other liquid.
- This product does not work while it is connected to the power outlet. Except when charging, always unplug this product from the power outlet.
- Remove power cord from power outlet and product before cleaning.

WARNING

To reduce the risk of burns, fire, electric shock, or injury to persons:

- This product is not intended for use by persons (including children) with reduced physical, sensory or mental capabilities, or lack of experience and knowledge, unless they have been given supervision or instruction concerning use of the product by a person responsible for their safety. Children should be supervised to ensure that they do not play with the product.
- Use this product only for its intended household use as described in this manual. Misuse can lead to hazards or serious injuries. Do not use attachments not recommended by Philips North America LLC.
- Never operate this product if it has a damaged power cord, if it is not working properly, after it has been dropped or damaged, or after the product or power cord has been dropped into water. For assistance call 1-800-243-3050.
- Keep the power cord away from heated surfaces.
- Never drop or insert any object into any opening.
- Do not use the power cord in or near a power outlet that contains an electric air freshener to prevent damage to the power cord.
- Do not use product outdoors or operate where aerosol (spray) products are being used or where oxygen is being administered.
- Always check cuttings units and other attachments and accessories before you use the product. Never use the product with a damaged cutting unit, attachment or accessory, as injury may occur.
- Always attach power cord to product first, then to power outlet. To disconnect, set all controls to 'off' position. Then remove power cord from power outlet.
- Plug power cord directly into power outlet. Do not use an extension cord.
- Unplug power cord before plugging in or unplugging the product.
- Only use the power cord and other accessories supplied with the product.
- The batteries used in this product may present a fire or chemical burn hazard if mistreated. Do not disassemble, heat above 100 °C (212 °F) or incinerate.

IMPORTANT: The power plug contains a transformer. Do not cut off the power plug to replace it with another plug as this will cause a hazardous condition.

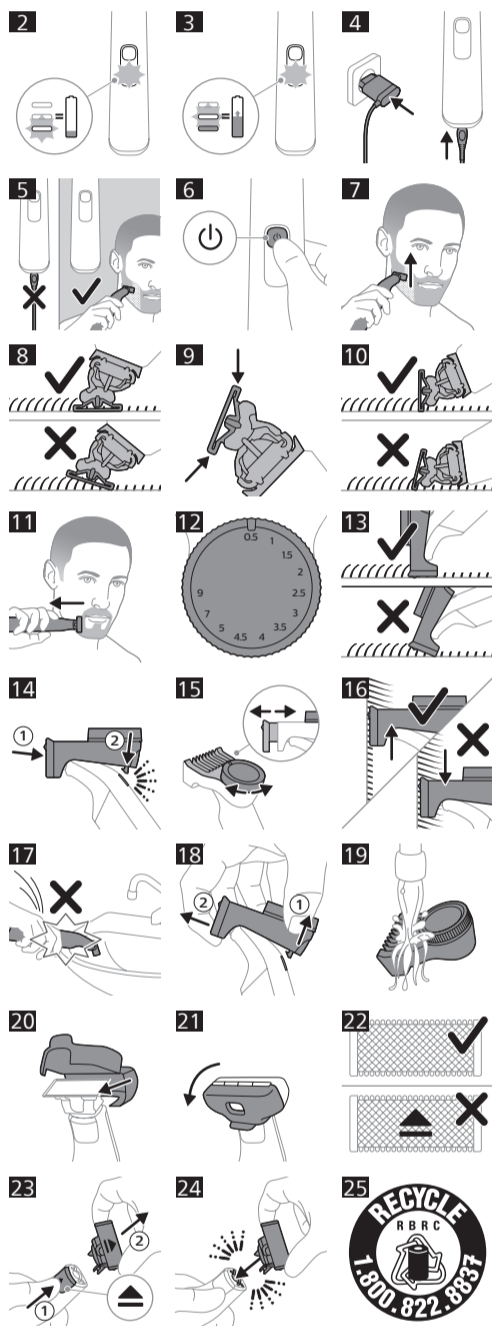
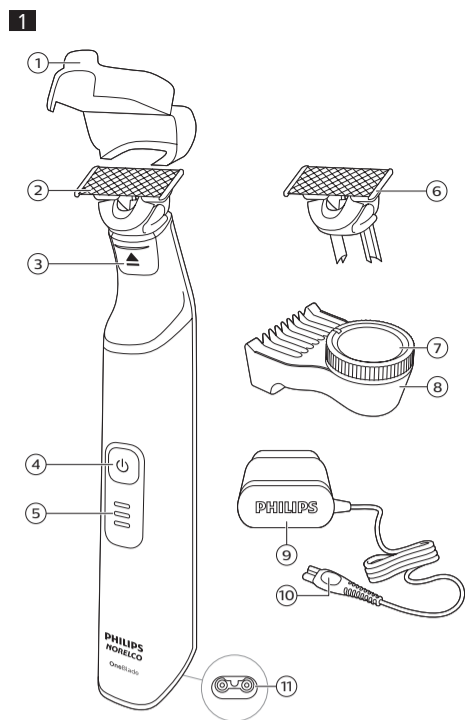

- Only use original Philips accessories or consumables. Only use detachable power cord HQ8505.
- Charge, use and store the product at a temperature between 40 °F / 4.5 °C and 95 °F / 35 °C.
- Keep product and batteries away from fire and do not expose them to direct sunlight or high temperatures.
- If the product becomes abnormally hot or smelly, changes color or if charging takes longer than usual, stop using and charging the product and contact Philips.
- Do not place products and their batteries in microwave ovens or on induction cookers.
- Do not open, modify, pierce, damage or dismantle the product or battery to prevent batteries from heating up or releasing toxic or hazardous substances. Do not short-circuit, overcharge or reverse charge batteries.
- If batteries are damaged or leaking, avoid contact with the skin or eyes. If this occurs, immediately rinse well with water and seek medical care.
- When you handle batteries, make sure that your hands, the product and the batteries are dry.
- To avoid accidental short-circuiting of batteries after removal, do not let battery terminals come into contact with metal objects (e.g. coins, hairpins, rings). Do not wrap batteries in aluminum foil. Tape battery terminals or put batteries in a plastic bag before you discard them.

SAVE THESE INSTRUCTIONS

Introduction

Congratulations on your purchase and welcome to Philips Norelco!

To fully benefit from the support that Philips Norelco offers, register your product at www.philips.com/register.

You can find the model number on the back of your product.

The full model number (e.g. QP1234/56) is located on the bottom of the packaging, your receipt or order confirmation.

General description (Fig. 1)

- 1 Protection cap
- 2 Blade
- 3 Blade release slide switch
- 4 On/off button
- 5 Battery charge indicator
- 6 Extra blade
- 7 Hair length setting wheel
- 8 Precision trimming comb
- 9 Power plug
- 10 Small plug
- 11 Socket for small plug



This symbol indicates that the product can be used in the bath or shower.

The display

Battery low

- When the battery is almost empty, the bottom light of the battery charge indicator starts flashing orange (Fig. 2).

Charging

- When the product is charging, the bottom charging light starts flashing white, then the next one and so on (Fig. 3).

Battery full

- When the product is fully charged, all battery charge indicators light up white.

Remaining battery charge

- The remaining battery charge is indicated by the lights of the battery charge indicator that light up continuously.

Charging

Charging takes approx. 1 hour.

- Charge the product before first use and when the display indicates that the battery is almost empty.

PHILIPS

NORELCO

OneBlade

QP6531



www.philips.com/support/ifu

BC

3000.094.0446.1 (07/20/2022)

reserved.

©2022 Philips North America LLC. All rights

trademarks of Koninklijke Philips N.V.

PHILIPS and Philips shield are registered

North America LLC.

Norelco is a registered trademark of Philips

Laboratories, Inc.

This symbol on the product's nameplate

means it is listed by Underwriters'

a division of Philips North America LLC

P.O. Box 10313, Stamford, CT 06904, USA

Manufactured for: Philips Personal Health



- Charging or using the product at temperatures below 40 °F (4.5 °C) or higher than 95 °F (35 °C) adversely affects the lifespan of the battery.
- If the product is subjected to a major change in temperature, pressure or humidity, let the product acclimatize for 30 minutes before using.

Quick charge: During quick charge, all three lights of the battery charge indicator light up. After approx. 5 minutes of charging, the product contains enough energy for 5 minutes of use. When quick charge is finished, the bottom light of the battery charge indicator starts to flash.

Charging with the power cord

- 1 Make sure the product is switched off.
- 2 Insert the small plug into the product and put the power plug in any 120V AC outlet (Fig. 4).
- 3 After charging, remove the power plug from the wall outlet and pull the small plug out of the product.

Note: Approx. 30 minutes after the battery is fully charged or when you disconnect the product from the outlet, the battery charge indicator switches off automatically.

Running time

When the product is fully charged, it has a cordless running time up to 90 minutes.

Using the product

Note: This product is for cordless use only (Fig. 5).

- Use this product for its intended household use as described in this manual.
- For hygienic reasons, the product should only be used by one person.
- Trimming is easier when the skin and hair are dry.
- Use the product to trim, edge or shave facial hair (beard, mustache and sideburns).
- Trim with the trimming comb to obtain a certain length.
- Take your time when you first start to use the product. You have to gain practice with the product.
- Allow some time for the skin to adjust to the product.
- Use the blade on a clean face. The blades go blunt faster if on skin that isn't clean.
- Do not use the blade when damaged or broken. Replace the blade immediately if it is damaged.

This product is not intended for shaving, edging or trimming hairs on lower body parts or scalp hair.

Switching the product on and off

- 1 Press the on/off button once to switch the product on or off (Fig. 6).

Shaving

- Shave off any length of hair. The product does not shave as close as a traditional blade so your skin will stay comfortable.
 - Make sure that the blade is in full contact with the skin by placing it flat on the skin.
 - For the best result, move the product against the grain.
 - Make long strokes while pressing lightly.
 - Use the product dry or wet with gel or foam, even in the shower.
 - Shaving a clean beard and face gives the best results.
- 2 Switch on the product (Fig. 6).
 - 3 Place the blade on the skin and move the product upwards or against the grain in long strokes while pressing lightly (Fig. 7).

Note: Make sure you hold the surface of the blade flat against your skin (Fig. 8).

- 4 Switch off and clean the product after each use (see 'Cleaning').

Edging

- Use both edges of the blade to create sharp lines and perfect edges.
 - Hold the product in such a way that the blade is perpendicular to the skin and one of its edges touches the skin. This allows more precise detailing of sideburns and the area around the mouth and nose.
- 1 To create sharp edges and lines, you can use either edge of the blade (Fig. 9).
 - 2 Switch on the product (Fig. 6)

- 3 Place the edge of the blade perpendicular onto the skin (Fig. 10).
- 4 Make straight strokes while applying gentle pressure (Fig. 11).
- 5 Switch off and clean the product after each use (see 'Cleaning').

Using the precision trimming comb

- The precision trimming comb allows you to trim hair to different lengths. When you trim for the first time, start at the highest length setting to familiarize yourself with the product.
- The settings on the wheel correspond to the remaining hair length after trimming in millimeters. You can select a length from 0.5 mm (1/64 in.) to 9 mm (23/64 in.) (Fig. 12).
- Always trim in the direction of the teeth of the precision trimming comb, making sure that the flat part of the comb is in full contact with the skin for an even trimming result (Fig. 13).
- Since all hairs do not grow in the same direction, you may want to try different trimming directions (i.e. upwards, downwards, or across). Practice is best for optimum results.
- Make sure to always move the product against the grain.
- Trimming is easier when the skin and hair are dry.

- 1 Place the front part of the comb onto the blade and push the projection at the back of the comb into the product ('click') (Fig. 14).
- 2 Turn the hair length setting wheel to select the desired hair length setting (Fig. 15). The settings on the wheel correspond to the remaining hair length after trimming.
- 3 Switch on the product (Fig. 6).
- 4 Place the comb onto the skin and move the product upwards slowly, against the grain (Fig. 16).
- 5 Switch off and clean the product after each use (see 'Cleaning').
- 6 To remove the comb, pull the back part off the product and then slide the comb off the blade (Fig. 18).

Cleaning

Clean the product after every use.

Never use scouring pads, abrasive cleaning agents or aggressive liquids such as gasoline or acetone to clean the product.

Do not tap the product or blade against a surface to remove hairs and water as this may cause damage to the product and blade (Fig. 17). If the blade is damaged, replace immediately.

Never dry the blade with a towel or tissue, as this may cause damage.

Cleaning the product

- 1 Switch off the product.
- 2 Remove the comb from the blade (Fig. 18).
- 3 Blow off any hairs that have accumulated on the blade and/or comb.
- 4 Switch on the product for approx. 15 seconds and rinse the blade with lukewarm water.
- 5 Rinse the comb for approx. 15 seconds with lukewarm water (Fig. 19).
- 6 Carefully shake off excess water and let all parts air dry completely.

Note: The blade is fragile. Handle it carefully. Replace the blade immediately if it is damaged.

This product has no other user-serviceable parts. For assistance call 1-800-243-3050.

Storage

Always put the protection cap on the blade to protect the blade from damage during travel or storage.

We advise you to let the product and its attachments dry completely before you store them for the next use.

- 1 Place the protection cap onto the edge of the blade (Fig. 20).
 - 2 Close the protection cap (Fig. 21).
- Charge the battery before storing the product for an extended period.

- Be sure the product is switched off. Remove the power cord from power outlet and the product before storing it in a safe, dry location where it will not be crushed, banged, or subject to damage.
- Do not wrap cord around the product when storing.
- Store cord and other accessories in a safe location where these will not be cut or damaged.
- Do not place or store the product where it can fall or be pulled into a tub or sink, water or other liquid while plugged in.

Replacement

Blade wear indicator

For optimal cutting and gliding performance, replace the blade every 4 months or when it no longer provides the shaving or trimming results you expect. This advice is based on two full shaves a week and actual results may vary. Depending on your usage behavior, the exact lifetime of the blade could be longer or shorter. Similar to a manual blade, the blade becomes blunt over time, which results in increased hair pulling and reduced cutting performance.

A replacement symbol will gradually appear on the blade as you use it (Fig. 22). When the replacement symbol is fully visible, it's time to replace your blade.

Note that accessories such as guards can prevent the replacement symbol from becoming visible.

Tip: the replacement symbol resembles the icon on the blade release button of your OneBlade. For older blades, a green rectangle may appear in place of the replacement symbol.

Replacing the blade

- 1 Make sure that the product is switched off.
- 2 Carefully push the blade release slide switch upwards while holding the blade on both sides (Fig. 23). This prevents the blade from being ejected from the handle.
- 3 Hold the new blade on both sides and press it onto the handle ('click') (Fig. 24).

Note: Be careful, the edges of the blade are sharp. When you hear a click, the new blade is placed correctly and ready for use.

Accessories

Replacement parts and accessories may be purchased at a store near you or on our website www.philips.com/store.

The following accessories are available:

- Model QP210 Philips Norelco Replacement Blade, 1-Pack
- Model QP220 Philips Norelco Replacement Blade, 2-Pack
- Model QP230 Philips Norelco Replacement Blade, 3-Pack
- Model QP610 Philips Norelco Body Kit
- Model QP620 Philips Norelco Face + Body Kit

Assistance

For assistance, visit our website:

www.philips.com/support or call toll free 1-800-243-3050.

Online information is available 24 hours a day, 7 days a week.

Disposal

- This product contains a rechargeable lithium-ion battery which must be disposed of properly.
- Contact your local town or city officials for battery disposal information. You can also call 1-800-822-8837 or visit www.call2recycle.org for battery drop-off locations (Fig. 25).
- For assistance, visit our website www.philips.com/support or call 1-800-243-3050 toll free.
- Your product is designed and manufactured with high quality materials and components, which can be recycled and reused. For recycling information, please contact your local waste management facilities or visit www.recycle.philips.com.

Full Two-Year Warranty

Philips North America LLC warrants this new product (except blade and comb) against defects in materials or workmanship for a period of two years from the date of purchase, and agrees to repair or replace any defective product without charge.

IMPORTANT: This warranty does not cover damage resulting from accident, misuse or abuse, lack of reasonable care, the affixing of any attachment not provided with the product or loss of parts or subjecting the product to any but the specified voltage or batteries.*

NO RESPONSIBILITY IS ASSUMED FOR ANY SPECIAL, INCIDENTAL OR CONSEQUENTIAL DAMAGES.

In order to obtain warranty service, simply go to www.philips.com/support for assistance. It is suggested that for your protection you return shipments of product by insured mail, insurance prepaid. Damage occurring during shipment is not covered by this warranty.

NOTE: No other warranty, written or oral, is authorized by Philips North America LLC.

This warranty gives you specific legal rights, and you may also have other rights which vary from state to state. Some states do not allow the exclusion or limitation of incidental or consequential damages, so the above exclusion and limitations may not apply to you.

*Read enclosed instructions carefully.

45-DAY MONEY-BACK GUARANTEE

If you are not fully satisfied with your product send the product back and we'll refund you the full purchase price.

The product must be shipped prepaid by insured mail, insurance prepaid, have the original sales receipt, indicating purchase price and date of purchase, and the money-back guarantee return authorization form enclosed.

We cannot be responsible for lost mail.

The product must be postmarked no later than 45 days after the date of purchase. Philips reserves the right to verify the purchase price of the product and limit refunds not to exceed suggested retail price.

To obtain the money-back guarantee service, please go to www.PhilipsMoneyBack.com and follow the simple 3-step process.

Delivery of refund check will occur 6-8 weeks after receipt of returned product.