

PHILIPS

智能馬桶

智能潔淨廁板

AIB2211/97



User Manual
說明書

Directory

1. Important	01
2. Safety caution	02
3. Preparations before installation	07
4. Packing list	09
5. Installation steps	10
6. Main technical specifications	13
7. About the the side button	14
8. About the remote controller	15
9. How to use	16
10. Maintenance	18
11. If a long idle period is expected	20
12. SIAA antibacterial certification instructions	21
13. Troubleshooting	22
14. List of environmental protection	24
15. Product Warranty Service Guide	25

Please read this installation instruction carefully and install this product correctly and safely.

Be sure to read pages 2 to 6 before installation (Safety Caution).

The manufacturer shall not be liable for any accident or injury caused by failure to install according to the instructions specified in the installation manual or failure to use specified parts during installation.

1. Important

Please read this instruction carefully before use.

- The product must be repaired by an authorized professional service personnel, otherwise the manufacturer will not be responsible for the corresponding warranty.
- The power supply component is coupled with the machine. If the power supply component is damaged, in order to avoid danger, it must be replaced by an authorized professional personnel from the manufacturer, otherwise the manufacturer will not be responsible for the corresponding warranty.
- Do not use non-original filter elements, which may cause health and safety risks. The water supply may become abnormal if non-original filter elements are used.
- The product is designed for domestic use, if it is used for commercial purposes, the service life of this product will be shortened.
- Do not install in outdoor.
- Users should check and maintain the product regularly. If there is any abnormality, users should stop using the product immediately and call the service hotline to report a repair.
- Before any maintenance or cleaning of the product, please be sure to disconnect the power supply.
- If any part has been soaked in water, it should be checked or repaired by an authorized service professional before use.
- Please do not cover the product with any object.
- Do not put heavy objects on the product.
- Do not use the product when the sewer is blocked.
- The company has the right to interpret the above terms and conditions as permitted by law.

2. Safety Caution

- Before use, please read the following safety precautions carefully.
- Improper use of the product may cause serious accidents.
- The following content is closely related to safety, please be sure to strictly comply with the requirements.



Warning: Refers to the contents that may cause serious personal safety or property damage.



Caution: Refers to the contents that may cause general personal safety or property damage.

This symbol is used with the above "Warning" and "Caution" contents to draw your attention. Please read it carefully and strictly follow it.	Refers to something that must not be performed.	This symbol indicates that please refer to operation instructions.



WARNING



The power supply must be earthed with three-pin power plug.

- Otherwise it can be a cause of electrocution and so on.



1. Unplug the power plug and turn off the faucet immediately when the product or the water inlet pipe leaks.
 - Otherwise there will be electric shock, fire hazard, or indoor seeper.
2. In cold winter, be sure to take anti-freezing measures.
 - Otherwise, the internal water may freeze and will lead to fire hazard and indoor seeper.
3. For long time sitting, please adjust the sitting temperature to "normal temperature" gear.
 - There is a risk of cryogenic burns when using temperature other than "normal temperature" for a long time.

4. When inserting and unplugging the power plug, hold the plug body.

- There is a risk of breakage of the plug or cable, electric shock or fire hazard if you handle the part of the wire.



This picture is for reference only

5. The power plug should be removed from the socket regularly and wiped with a dry cloth.

- Dust that accumulates in power plugs can cause a fire hazard.

6. The power plug should be fully inserted.

- Otherwise there will be electric shock, fire hazard risk.

7. People with physical, sensory, intellectual disabilities or lack of experience and common sense (such as the following) should adjust the temperature of the seat to normal temperature.

- Children
- The elderly
- The patient
- People who are unable to regulate their own temperature
- People who have weak skin
- People who take hypnotic drugs such as sleeping pills
- People who consumed too much alcohol
- People who are extremely tired
- There is a risk of cryogenic burns when using temperature other than "normal temperature" for a long time.



PROHIBITION



1. Please contact the after-sales service for repair, otherwise there is a risk of injury.
2. - Do not use broken plugs or faulty sockets.
 - Do not replace the power plug or power cord by yourself.
 - If the power supply cord is damaged, to avoid danger, it must be replaced by an authorized service professional from the manufacturer.
 - Otherwise, it may cause electrical leakage, fire hazard and injury.
3. Do not scratch, damage, process, forcibly bend, stretch, tighten, bind, press, or shorten the power cable.
 - Otherwise, the power cable will be damaged, which may lead to electric shock and fire hazard.
4. To avoid the risk of accidental reset of the thermal circuit breaker, the product should not be installed in sockets with external switching devices, such as timers.
 - Otherwise, the leakage circuit breaker cannot operate normally, which may lead to a fire hazard.
5. - Do not use voltage other than AC220V.
 - Do not overload the circuit.
 - Otherwise there could cause a fire hazard.

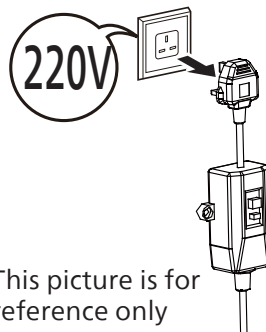

6. Do not use water to clean the fuselage and power plug.
 - May cause malfunction or electric shock.



1. Please use the installation accessories delivered with the product (old hose assembly cannot be reused).
 - Otherwise there will be water leakage or failure to install.



Do not touch with wet hands

Do not remove or insert the power plug with wet hands.

- Otherwise it can be a cause of electrocution.



Do not disassemble

If the product is faulty, please immediately shut down and unplug the power plug. Bring it to the customer service center, do not dismantle or modify the product by yourself.

- Otherwise, it may cause electrical leakage, fire hazard and injury.



Do not touch water

The product and its power plug should be installed in a position where water or detergent can't be spilled.

- Otherwise, it may cause electrical leakage and fire hazard.



ATTENTION



1. Do not use inappropriate cleaners when cleaning and maintaining plastic parts.
 - Use of toilet detergent, residential detergent, bleach, gasoline, thinner, detergent, cresol, etc., will lead to plastic damage, injury, electric shock, or fire risk.
2. Always remove the power plug from the socket when cleaning.
 - Otherwise, there will be the danger of electric shock.
3. If the product will not be in use for a long time, drain the water and pull out the power plug from the socket.
 - Otherwise, there will be danger of fire and indoor seep caused by freezing damage.
 - Otherwise, the water inside the product will be contaminated, which will lead to the risk of skin inflammation.
4. When the following people use the product, please accompany them to prevent them from falling. (Children, the elderly, people who can't sit or stand on their own).
 - Children should not play with this product. Do not let children use this product alone.
 - Otherwise, people may be injured or the product cover may be damaged.
5. In the room where the product is installed, a water supply switch should be installed in the accessible position. This switch can be used to cut off the water inlet of the product



without tools in case of emergency. Otherwise, the accidental failure of the product may cause personal injury or property loss.

- Otherwise, water leakage may occur in emergency situations, resulting in indoor seeper.



1. Do not bend or break the inlet water pipe.

- Otherwise, water leakage will occur and lead to indoor seeper.

2. Do not touch or step on the faucet.

- Otherwise, water leakage will occur and lead to indoor seeper.

3. Do not lean your back against the bidet cover.

- Otherwise it may cause scratches or damage to the cover.



Do not place cigarettes and other combustible materials near the product.

- Otherwise, there will be the danger of fire.

3. Preparations before installation

Component identification

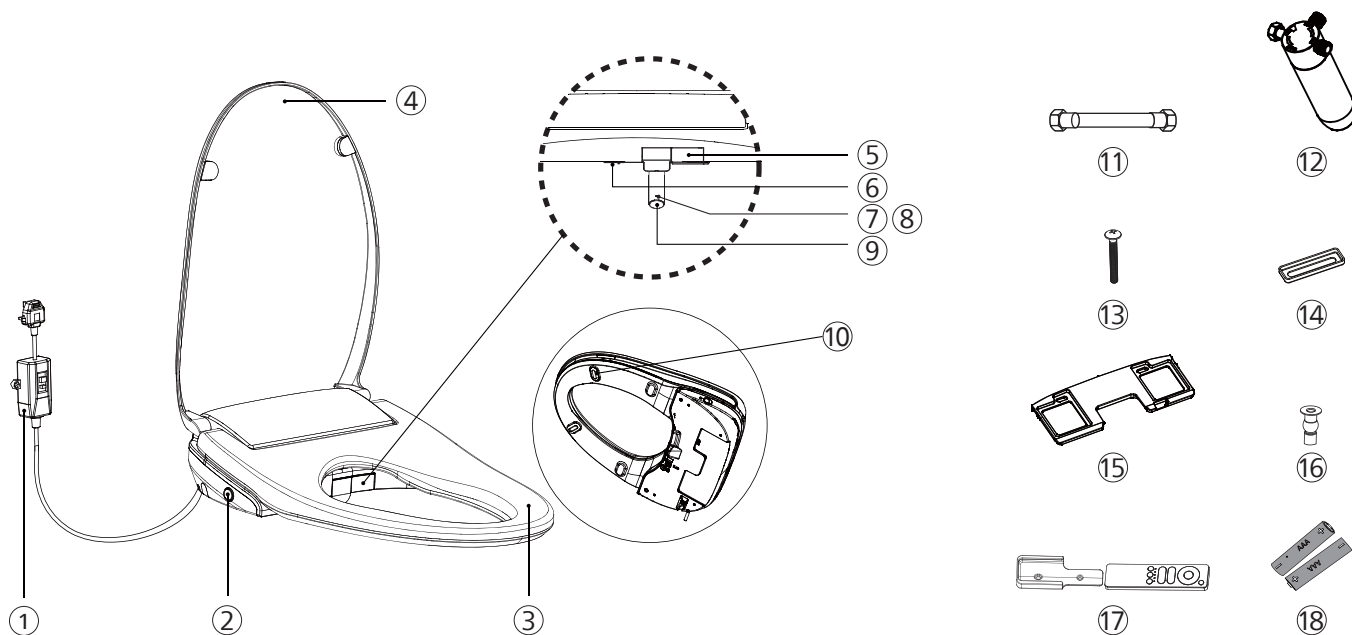

- | | |
|------------------------------------|-----------------------------|
| ① Electric leakage protection plug | ⑩ Buffering pads |
| ② The side button | ⑪ Inlet water pipe |
| ③ Bidet seat | ⑫ Filter |
| ④ Upper cover | ⑬ Bolts |
| ⑤ Warm dry | ⑭ Adjustment sheet |
| ⑥ Night light | ⑮ Fixed plate |
| ⑦ Front wash plughole | ⑯ Expanding nuts |
| ⑧ Rear wash plughole | ⑰ Remote control and holder |
| ⑨ Nozzle | ⑱ Battery |

Preparations before installation

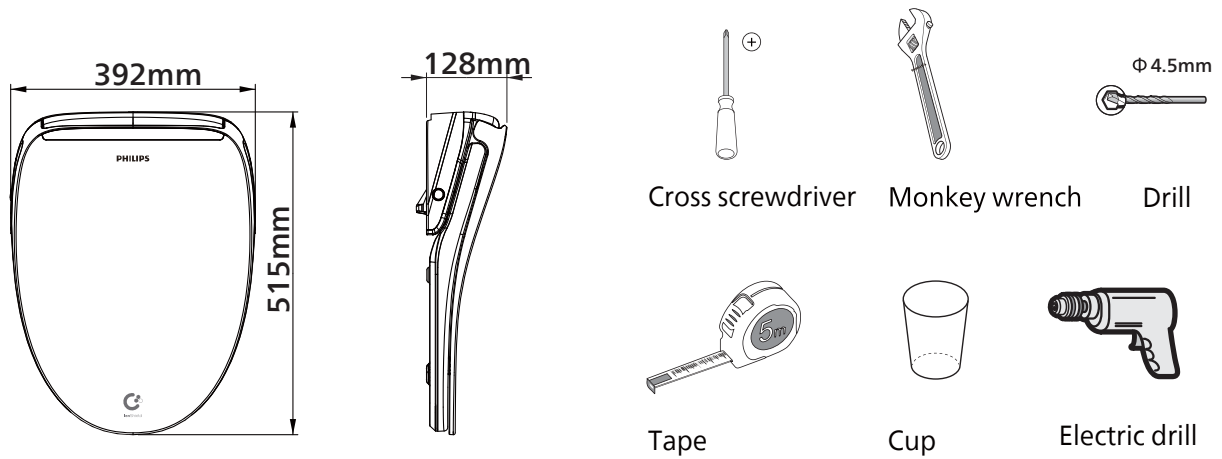

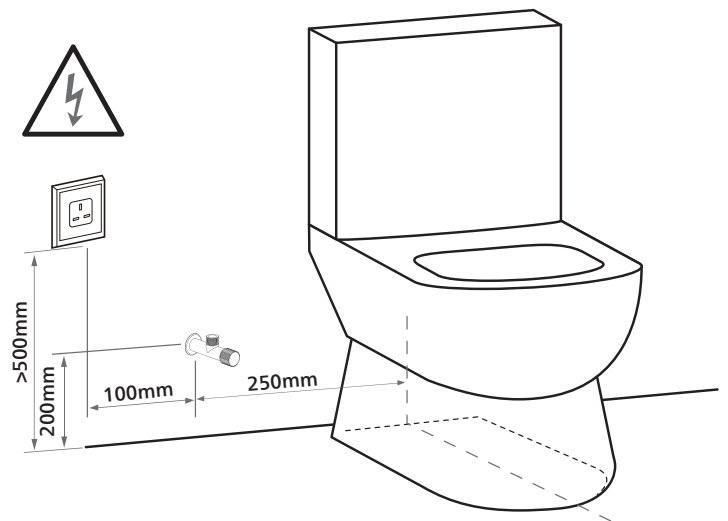

Suggestions for connecting power supply and water inlet.

In the room where the product is installed, a water supply switch should be installed in the accessible position. This switch can be used to cut off the water inlet of the product without tools in case of emergency. Otherwise, the accidental failure of the product may cause personal injury or property loss.

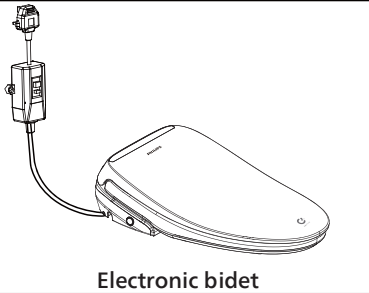
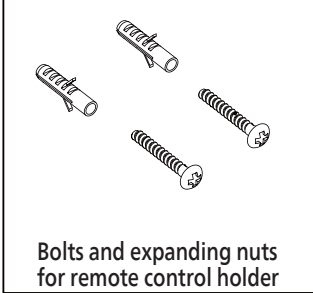
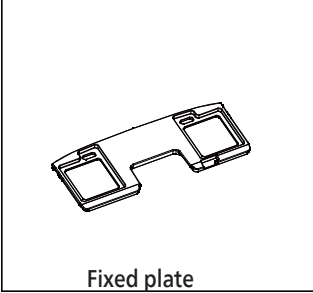
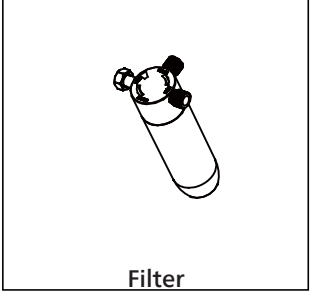
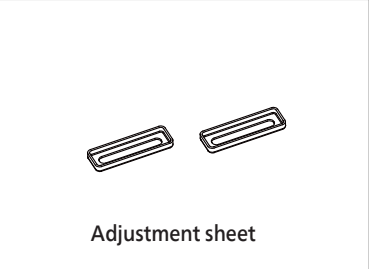
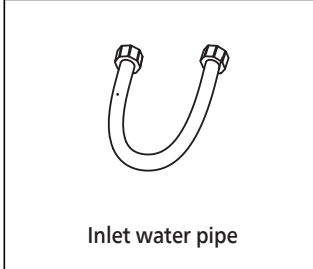
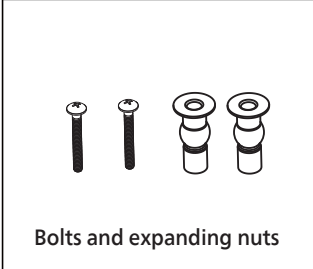
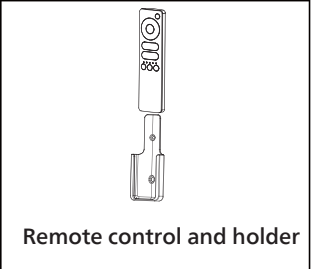

4. Packing list

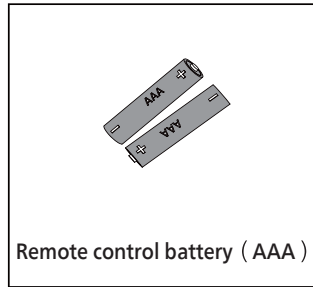
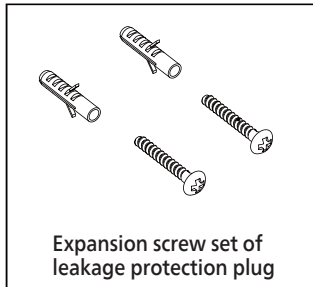
 Electronic bidet	 Bolts and expanding nuts for remote control holder	 Fixed plate	 Filter
 Adjustment sheet	 Inlet water pipe	 Bolts and expanding nuts	 Remote control and holder
 User manual	 Remote control battery (AAA)	 Expansion screw set of leakage protection plug	

list

Designation	Quantity	Remark
Electronic bidet	1 set	
Fixed plate	1 pcs	Remove from bottom of product
Filter	1 pcs	
Adjustment sheet	2 pcs	
Inlet water pipe	1 pcs	
Bolts and expanding nuts	2 pairs	
Remote control and holder	1 set	
User manual	1 pcs	
Remote control battery (AAA)	2 pcs	
Bolts and expanding nuts for remote control holder	2 pairs	
Expansion screw set of leakage protection plug	1 set	

5. Installation Steps

This product has been tested before delivered in the factory, there may be a small amount of residual water droplets when taking out the product, which is not a fault.

Remove the fixing plate from the host first.

1. As shown in the picture, install the expanding nuts, fixed plate, adjustment sheet in order. Then fix the bolts of fixed plate but not completely tightened.

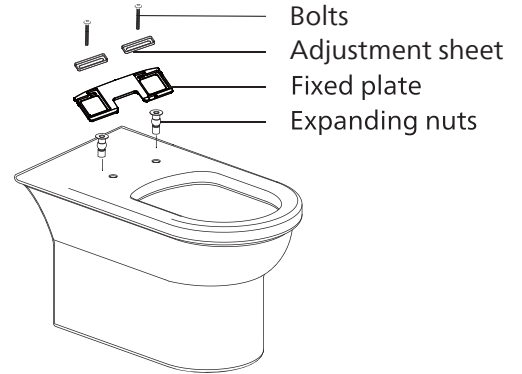

2. Install the bidet into the fixed plate installed on the ceramic for trial installation, adjust the position, then press the side of the product push rod to remove the product, screw the bolts down.

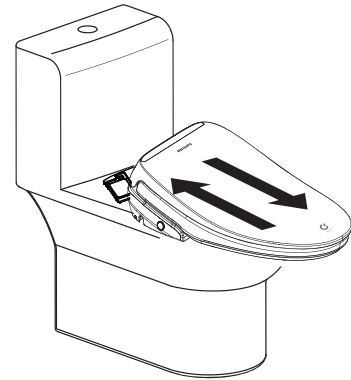

3. Align the bottom of the product with the fixing plate slot, push it horizontally, till hear the "click" sound.

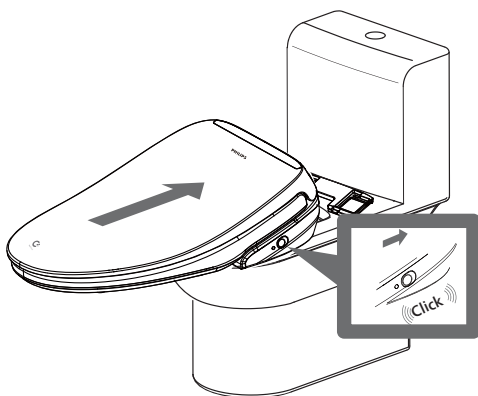

4. **Note:** Connect each water inlet pipe to the correct position of the filter.

Connect the strainer to the Angle valve and connect two water pipes.

Toilet fresh water inlet pipe (if applicable)

Filter

Bidet fresh water inlet pipe

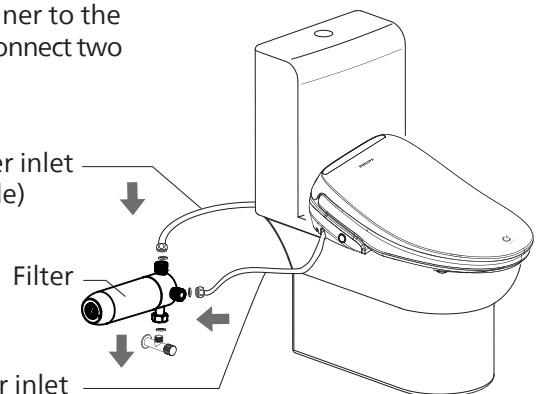

5. Install the remote control.

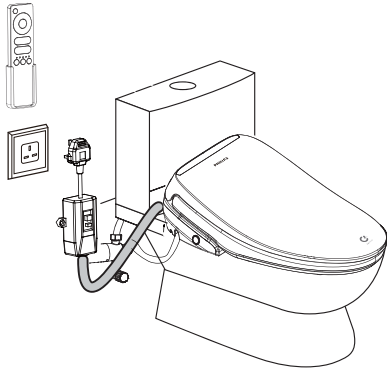

Swipe up to remove the remote control.
Swipe down to put the remote control back.

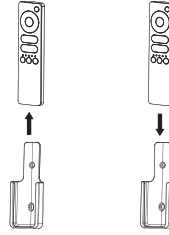

A. Drill two 4.5mm diameter holes with a depth of >20mm in appropriate positions on the wall according to the position dimensions shown.

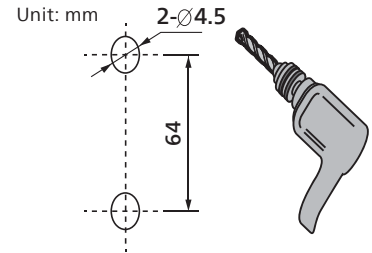

B. Install the expansion nut into the drilled hole.

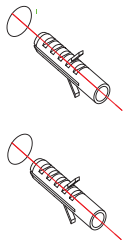

C. Secure the remote control holder with expansion screws.

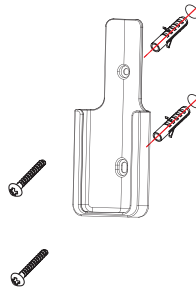

D. Battery installation

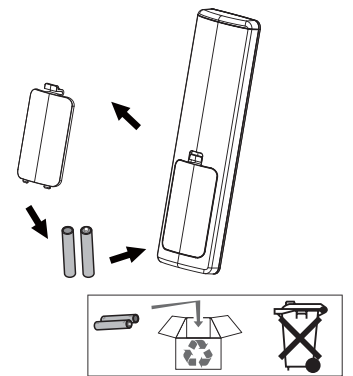

6. Connect the water

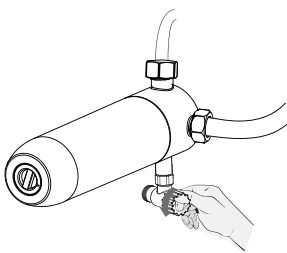

Turn on the tap

7. Switch on the plug

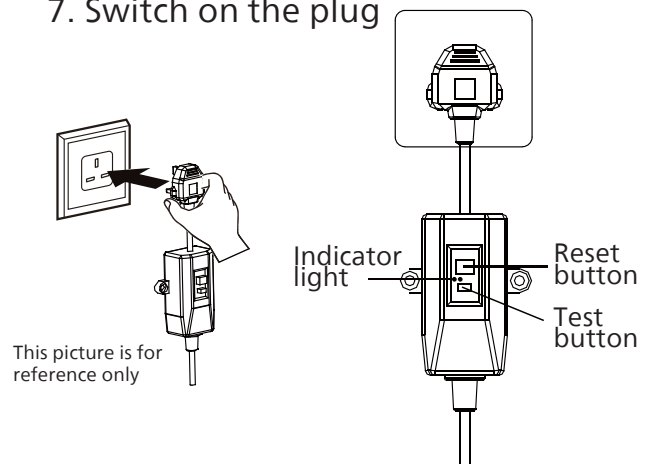

Leakage protection test

- (1) Under normal condition, press the "RESET" button on the power plug, the plug indicator light will be green and the product will start to power on, enter the standby state;
- (2) Press the "TEST" button on the power plug, the plug indicator light will be off and the product is powered off;
- (3) Press the "RESET" button on the power plug again, the indicator light will be green, and the power supply of the product will be restored.

⚠ Warning

- Check if any leakage occurs when the power switch does not work properly.
- The leakage protection plug only protects the product connected to the power supply through the plug. When using other electrical appliances, the product does not guarantee the leakage protection of other products; similarly, the product does not replace the basic safety measures of other electrical appliances.
- Do not ground the live wire directly, test the leakage protection function of the product plug.

8. Function test

Test run

Gently cover the sensing position on the seat with your hand, and at the same time press the rear wash/front wash button to check whether the nozzle is working properly. Please block the nozzle outlet with a cup to prevent water from splashing on yourself or the floor.

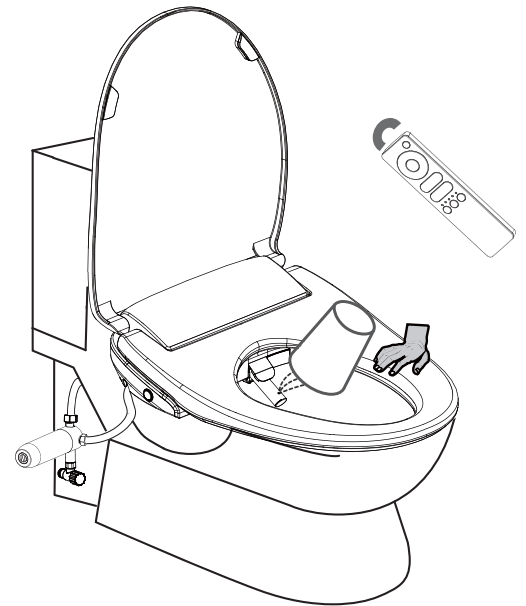

9. Fixing of leakage protection plug

A. Drill two 4.5mm diameter holes with a depth of >20mm in appropriate positions on the wall according to the position dimensions shown.

Unit: mm

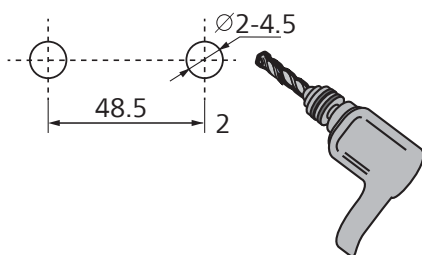

B. Install the expansion nut into the drilled hole.

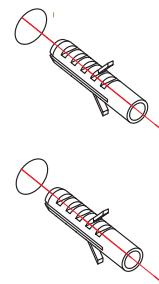

C. Fix the leakage protection plug with expansion screw.

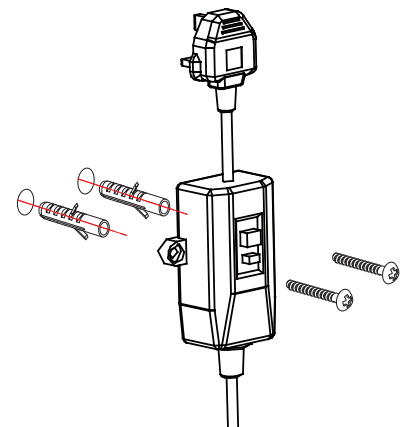

6. Main technical specifications

	Designation	Electronic bidet
	Model	AIB2211/97
Wash	Rear wash	●
	Front wash	●
	Child wash	●
	Moving wash	●
	Water pressure adjustment	5 level setting
	Water temperature adjustment	5 level setting + normal temperature level
	Nozzle position adjustment	5 level setting
Warm dry	Warm dry	●
	Air temperature adjustment	3 level setting + normal temperature level
Seat and cover	Seat temperature adjustment	5 level setting + normal temperature level
	Antibacterial seat	●
	Soft closing seat and cover	●
Inductor	Seat sensor	●
Clean and sanitary	Antimicrobial nozzle	●
	Nozzle self-cleaning	●
Else	Night light	●
ECO	ECO setting	●
The rated voltage		220V~
Rated frequency		50Hz
Rated power		820W
Maximum input power		1050W
The environment temperature		0°C~40°C
Supply pressure		0.07MPa~0.75MPa
Water supply temperature		3°C~35°C
Waterproof level		IPX4
Wash flow		about 250~550ml/min (static pressure 0.2MPa)
Warm water for wash	Water temperature	Inlet water temperature ~41°C
	Heater power	1000W
Warm seat	Seat temperature	Room temperature ~41°C
	Heater power	50W
Warm air	Warm air temperature	Room temperature ~60°C
	Maximum wind speed	≥4m/s
	Heater power	250W
Sterilizations	Function	IonShield
Product dimension		515X392X128mm

Explanation:

Rated power: Under the conditions of environmental temperature $23^{\circ}\text{C}\pm 2^{\circ}\text{C}$, static pressure of water inlet $0.2\text{MPa} \pm 0.02\text{MPa}$, water inlet temperature $15^{\circ}\text{C}\pm 0.5^{\circ}\text{C}$, the function of buttock washing is opened and the flow is adjusted to the maximum, the seat temperature and water temperature are set to the highest grade, and the average power of buttock washing is immediately started after stopping and the complete work of a cleaning cycle is completed.

Maximum input power:

The average power of this product under the conditions of environmental temperature $23^{\circ}\text{C}\pm 2^{\circ}\text{C}$, inlet static pressure $0.2\text{MPa} \pm 0.02\text{MPa}$, inlet temperature $5^{\circ}\text{C}\pm 1^{\circ}\text{C}$, the flow is adjusted to the maximum, the seat temperature and water temperature are set to the highest grade, and the buttock washing is immediately started and the complete work of a cleaning cycle is completed.

Best cleaning performance:

To achieve the maximum cleaning performance, it is necessary to adjust the water pressure and water temperature to the highest grade, open the buttock washing function, adjust the spray position to the most front end, after cleaning for 1 minute, adjust the nozzle position to the rear end, until the end of the washing cycle.

7. About the the side button

Since the design of this product is mainly controlled by remote control, the side button has only common basic functions, as shown in the figure below.

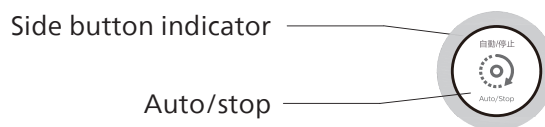

Introduction:

The side button contains two functions: automatic rear wash and front wash.

When seated, short press the button to activate automatic rear washing function: rear wash + moving wash + rear wash + warm dry.

When seated, long press the button (above 3 seconds) to activate automatic front washing function: front wash + moving wash + front wash + warm dry.



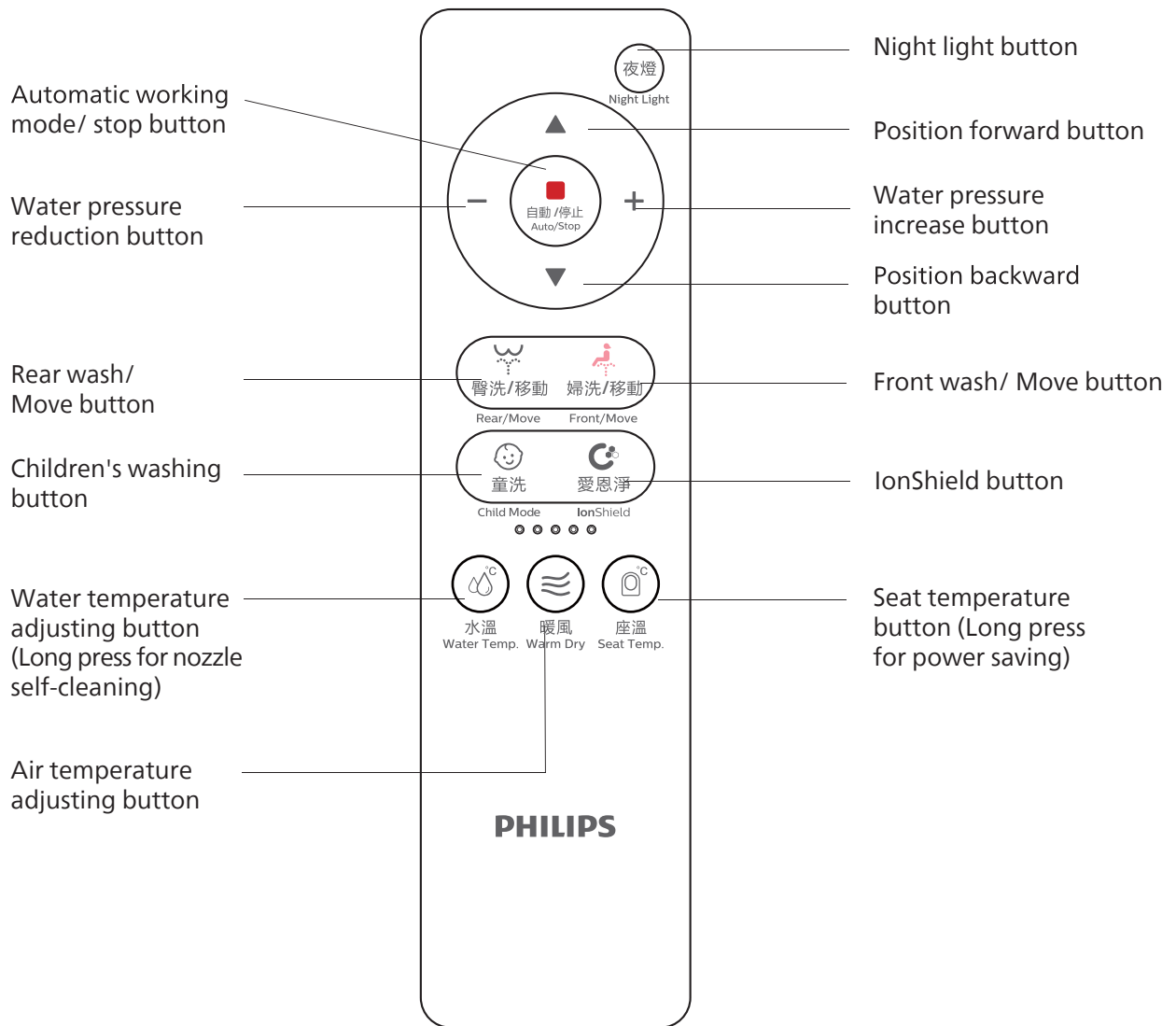

When unseated, long press the button (above 10 seconds), shut down all function, and the buzzer rings three times, the indicator light goes off and enters the standby state. When pressing any key or sitting, exit the standby mode.

8. About the remote controller







9. How To Use

1. Rear wash/ Move button

Press "  " button to enter the rear wash mode. After the nozzle is extended, fixed wash then mobile wash , and then restored to the fixed wash. It will stop automatically after rear wash for about 3 minutes or leaving the seat, or press the "  " button to stop working. In this mode, you may press "  " button to enter the mobile wash. Press "  " button again to stop the mobile wash.



2. Front wash/ Move button

Press "  " button to enter the front wash mode. After the nozzle is extended, fixed wash then mobile wash , and then restored to the fixed wash. It will stop automatically after front wash for about 3 minutes or leaving the seat, or press the "  " button to stop working. In this mode, you may press "  " button to enter the mobile wash. Press "  " button again to stop mobile wash.

3. Children wash

When sitting, briefly press "  " to start children's washing. First, switch the water pressure, water temperature and air temperature to the lowest gear for hip washing for 1 minute, and then automatically turn on the warm air for 2 minutes. After that, restore the previous water pressure, water temperature and air temperature.

4. Water temperature adjustment

Press "  " button, the indicator light shows the water temperature level; press "  " button again, the water temperature level can be switched, each level can be switched circularly, and the corresponding level indicator light is shown in the figure below:

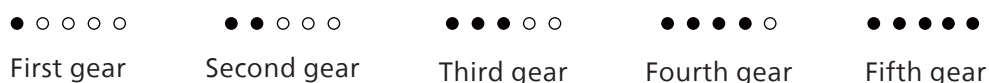

5. Water pressure adjustment

In rear wash / front wash mode, press " + " button once to increase the water pressure by one gear, a total of five gears; Each time you press the " - " button, the water pressure will be reduced by one gear, and a total of five gears can be adjusted.

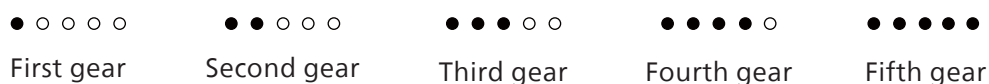

6. Position adjustment

Under the rear wash/ front wash mode, Each time you press the " ▲ " button, the water pressure increases by one gear, a total of five gears; Each time you press the

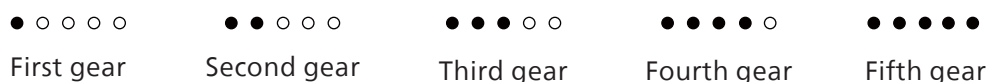

" ▼ " button, the water pressure will be reduced by one gear, and a total of five gears can be adjusted.



7. Nozzle Cleaning



If no people is sitting on the seat, long press "  " to automatically extend the nozzle for cleaning for about 2 minutes, operate the nozzle again to retract and self-clean.

8. Seat temperature setting

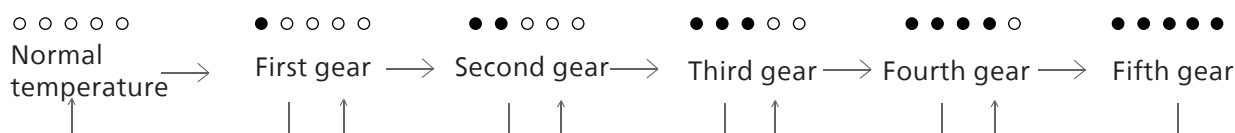

Press the "  " key, and the indicator light displays the seat ring temperature gear; press the "  " key again to cycle the seat ring temperature gear, and the indicator light is shown in the following figure:



9. Night light

Press the "  " button to turn on the night light, and then press the "  " button to turn off the night light.

10. Warm air function

- When seated, press "  " button to start the warm air function; it will stop automatically for about 5 minutes or after leaving the seat, or press the "  " button to stop working.
- In warm air mode, press the "  " button, the indicator light shows the wind temperature level; The wind temperature gear can be switched cyclically, as shown in the figure below.

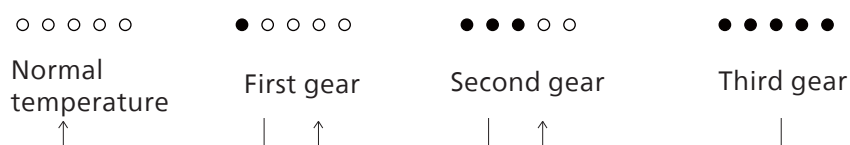

11. Power saving

Long press "  " button to turn on or off energy-saving mode.

12. Automatic working mode/stop button

- When sitting without other operations, press the "  " key of the remote control, enter the full automatic working mode. The working steps are as follows:
Rear wash→Oscillate wash→Rear wash→Warm air→stop.
- When the product function is in use, briefly press the key to stop the function.

13. IonShield

- In the off sitting state, press the "  " key to enter the nano water ion sterilization

function, short press for 1 hour and long press (≥ 35) for 2 hours.

- When the IonShield is turned on, the aperture on the side button shows strong and weak breathing effect;
- Short press the aperture for blue breathing lamp effect, long press the aperture for purple breathing lamp effect ; during the execution of IonShield, the lamp will remain on according to the above logic until the function is completed or stopped.
- After entering the IonShield sterilization function, if you press long / short to switch the sterilization time, the working time will be reset.
- During the operation of IonShield sterilization function, press "  " or sit down to automatically exit the nano water ion sterilization function.

10. Maintenance

When cleaning and maintaining this product, please pull out the power plug first, close the angle valve switch and cut off the power supply to avoid water leakage, electric shock and other hazards.

Bidet cleaning

1. Pull out the power supply, close the angle valve

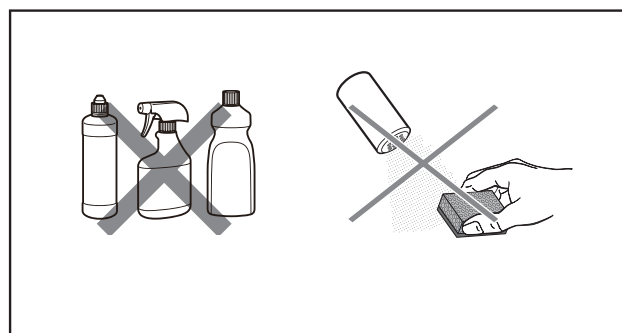
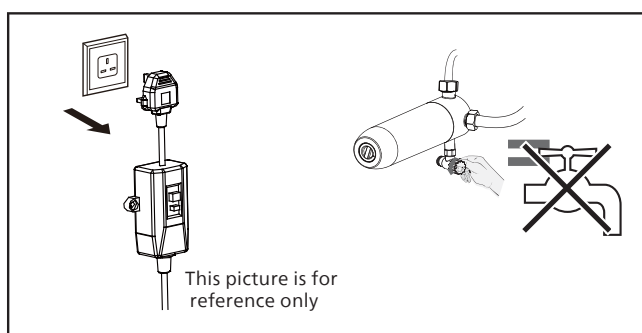

2. Bidet cover cleaning

Wipe with a soft cloth and water (to be wrung out)

Notes:

- The product surface is made of plastic. Do not wipe it with dry cloth or toilet paper. Otherwise, it may damage the appearance of the product;

- There are electronic components in the back cover of the product. Please pay attention to prevent water from seeping into it. Otherwise, it may lead to functional failure of the product;
- The transmitter and receiver of the remote control should be kept clean at all times.

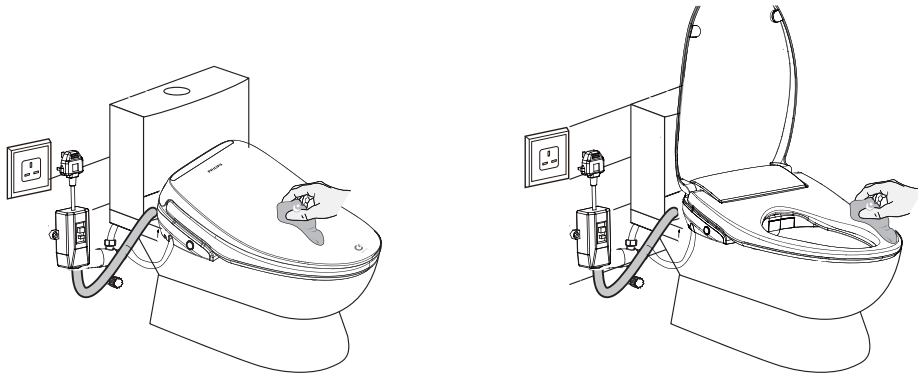

3. Remove the bidet



4. Clean the bidet and ceramics

After removing the bidet body, you can clean the left and right sides and bottom of the bidet, as well as around the ceramic surface.

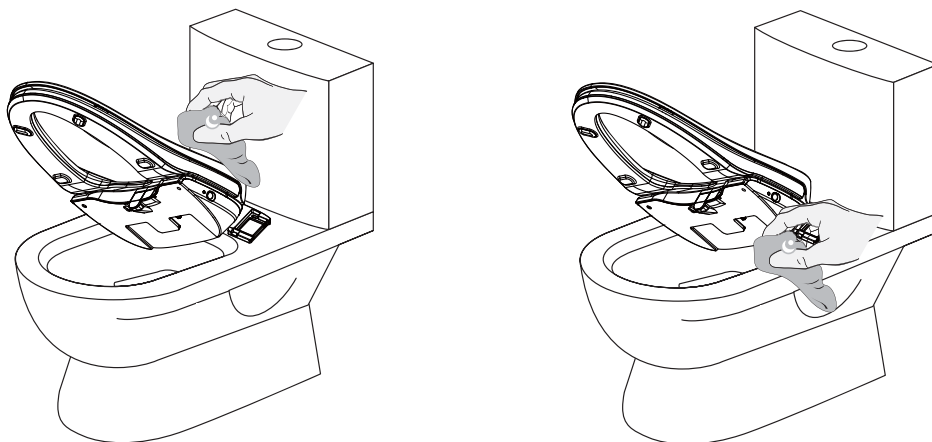

Nozzle Cleaning

When sitting away, long press the "Ⓞ" button. After the nozzle extends, wear rubber gloves, remove the nozzle and clean it with a toothbrush.

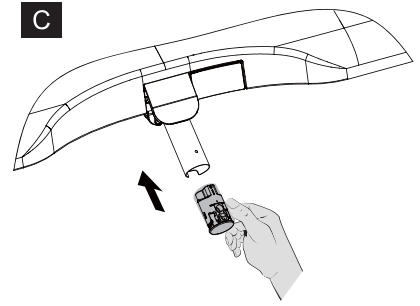
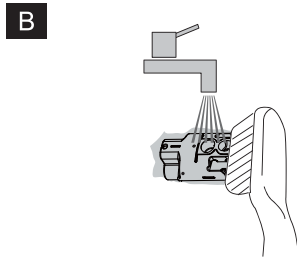
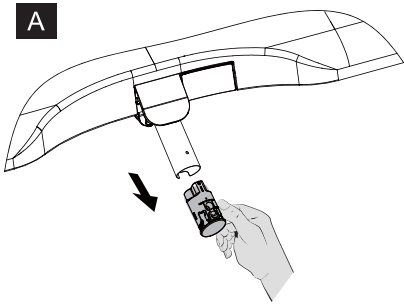

Replace the filter element

- It is recommended to replace the filter element once every 6 months (the specific service cycle depends on the water quality).

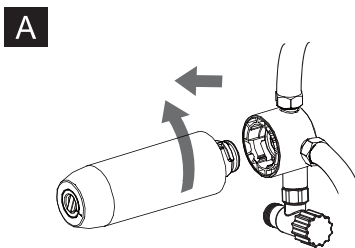

Turn off the water source first, then unscrew and remove the filter element.

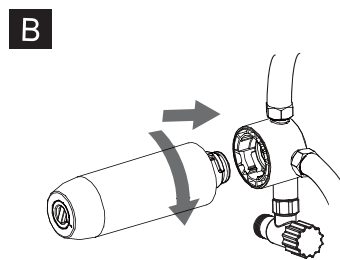

Install a new filter element.

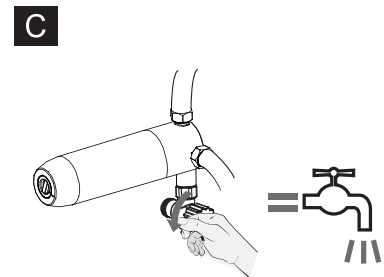

Turn on the water source.

11. If a long idle period is expected

When the following two situations are encountered:

- Not used for a long time (more than a week).
- The room temperature is lower than 0°C to prevent the product from freezing crack.

Please drain the water in the product pipeline according to the following steps:

Step 1: Tighten the water supply valve and cut off the water source.

Step 2: Press and hold key "  " for internal drainage.

Step 3: Unplug the power cord.

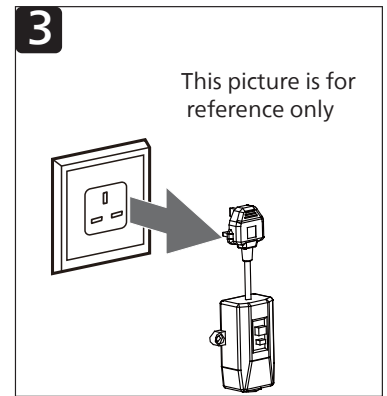
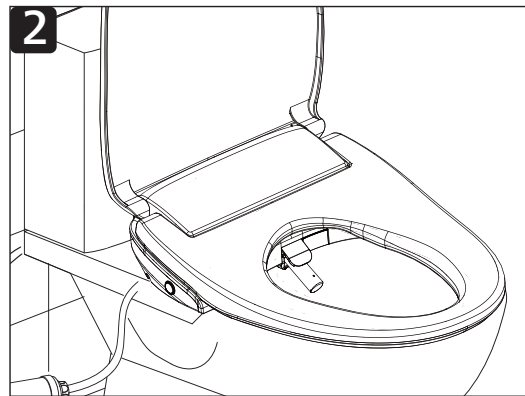
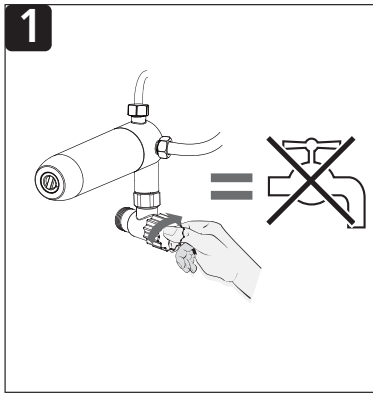

12. SIAA Antibacterial certification Instructions

The product seat ring material is certified by SIAA antibacterial Association, which can effectively inhibit the reproduction of Escherichia coli and Staphylococcus aureus, and the antibacterial rate is 99.9%

MICROKILLER®

Inorganic silver
antibacterial agent Mixing · Seat ring

CN0122781A00010

13. Troubleshooting

Phenomenon		Cause	Solution
The product doesn't work properly		The product is powered off.	Turn on the power supply.
Night light function	Night light off	The night light is set to "off".	Reset the night light assembly to "turn on" the night light.
	Night light on	The night light is set to "on".	Reset the night light assembly to "turn off" the night light.
Manual cleaning nozzle mode	Automatic retracting of nozzle	The nozzle will be automatically retracted 2 minutes after manual cleaning.	This is a normal phenomenon.
	Long press "Water temperature " button, the nozzle does not extend	There are conductive media on the seat, such as water droplets or wet paper, etc. The sensor will identify it as user.	Remove the conductive medium on the seat.
Rear wash/ Front wash/ Children wash	The nozzle extends out too slowly	When the front or rear wash function is activated, the nozzle will be automatically cleaned at the outlet and then extended. The operation takes a few seconds.	This is a normal phenomenon.
	Low water pressure	The water pressure is set to a lower mode.	Use the remote control to reset the water pressure to a stronger mode.
		The screen is clogged. The filter is clogged.	Clean the screen or replace the filter.
		The connecting nut of water supply hose is loosened.	Fasten the nut.
	Low water temperature	The water temperature is set to "low" or "normal temperature".	Use the remote control to reset the water temperature to a "high" or "medium" state.
	The nozzle suddenly stops spraying water	After 3 minutes of cleaning, the nozzle stops spraying water and retracts automatically.	This is a normal phenomenon.
Seat heating	The temperature of the seat is not high enough during use	The seat temperature is set to "normal temperature" or "low".	Reset the seat temperature to a higher state.
	Over-temperature of seat	The seat temperature is set to a higher level.	Reset the seat ring temperature to a lower state.

Warm air function	The warm air temperature is not high enough	Is the warm air temperature set to a lower state?	Reset the warm air temperature to a higher state.
	The function of warm air is not working properly	Wash function activated.	Turn off all wash functions, and then start the warm air function.
	The function of warm air stops suddenly	The user suddenly leaves the seat; the sensor cannot detect the correct position.	Please sit back on the seat and start the warm air function.
Indicator light and alarm function	The red light of the button on the product side flashes twice at one time	The water temperature is too high, and the water comes from the self-cleaning port constantly.	1. Set the water temperature to room temperature, wait for about 20s, and turn on the power supply again. 2. Stop using it when it cannot be eliminated. Please contact the service hotline.
	The red light of the button on the product side flashes once at one time.	The water inlet is off.	Turn on the water inlet and turn on the power again .
	The blue light of the button on the product side flashes once at one time	Seat ring temperature fault .	Cut off the power supply and stop using the product. Contact the service hotline.
	The red light of the button on the product side flashes four times at one time.	Water temperature sensor fault.	
	The blue light of the button on the product side flashes three times at one time	Seat temperature sensor fault.	
	The leakage protection switch on the power plug often trips.	The leakage exceeds the normal value.	
Remote control	The remote control doesn't work properly	Batteries ran out.	Replace new batteries
		The positive and negative electrodes of batteries set wrongly.	Set the positive and negative electrodes of batteries correctly.
	The remote control button is not sensitive	Batteries power low.	Replace new batteries.
		The remote control is too far from the product or not within the range of the sensor.	Please use the remote control within the range of effective induction.

14. List of environmental protection

According to the relevant provisions and requirements of the administrative measures for the restriction of the use of hazardous substances in electrical and electronic products of the people's Republic of China, the following forms including the name of electronic products and hazardous substances are provided.

Hazardous substances

Part name	Pb	Hg	Cd	Cr(VI)	PBB	PBDE
Power cord assembly	○	○	○	○	○	○
Shell plastic parts	○	○	○	○	○	○
Internal plastic parts	○	○	○	○	○	○
Internal hose	○	○	○	○	○	○
Internal hardware	○	○	○	○	○	○
Internal electrical parts	×	○	○	○	○	○
Circuit board	×	○	○	○	○	○
Tee assembly	×	○	○	○	○	○

This form is prepared in accordance with SJ / T11364.



○: Indicates that the content of the hazardous substance in all homogeneous materials of the component is below the limit specified in GB /T26572 standard.

× : Indicates that the content of the hazardous substance in at least one homogeneous material of the component exceeds the limit specified in GB /T26572 standard.

Above“ × ” The identified components have no replaceable technologies and components at this stage, and meet the regulatory requirements of the national measures for the administration of restrictions on the use of hazardous substances in electrical and electronic products.

Product recycling tips:

In order to protect the environment, according to the relevant provisions of the national regulations on the recycling of waste electrical and electronic products, when the user no longer needs this product or the service life of the product ends, the user is requested to send it to the recycling bin qualified for the disposal of waste electronic products for recycling.

15. Product Warranty Service Guide

- The product is guaranteed for two years from purchase date. If you need more information, please visit our website: www.philips.com/welcome.
- Within two years from the date of purchase, you will be guaranteed free of charge for any damage caused by manufacturing process or original parts under normal use confirmed by our service center.
- When repairing, please show the valid purchase certificate.
- This free service does not include consumable parts (cartridge, nozzle, ect.), auxiliary equipment, transportation costs and on-site service of maintenance personnel.

Free service will not be available in the following cases

1. Artificial damage caused by improper use, such as improper connection of parts, improper installation, failure to follow instructions, misuse or negligence.
2. Damage caused by transportation and other accidents.
3. Repair and modification not approved by the manufacturer.
4. Other damage caused by force majeure (such as natural disasters, abnormal voltage, etc.)
5. Damage caused by general use outside the home (industrial, commercial, etc.)
6. Product aging, wear and tear caused by normal use, but does not affect the normal use of the product.

The notice is an advertisement for free maintenance within the specified period and conditions, and does not limit the legal rights of consumers.

目錄

1. 重要事項	26
2. 安全注意事項	27
3. 安裝前準備事項	31
4. 裝箱清單	32
5. 安裝步驟	33
6. 主要技術規格	37
7. 側面按鍵概述	38
8. 遙控器版面概述	39
9. 使用方法	40
10. 維護保養	42
11. 長閒置期處理方式	44
12. SIAA抗菌認證說明	44
13. 故障診斷	45
14. 環保清單	47
15. 產品保修服務指南	48

請認真閱讀此安裝說明書後，正確、安全的安裝本產品。

安裝前請務必閱讀第27~30頁的“安全注意事項”。

若因未按安裝說明書所示方法安裝或安裝時未使用指定部件而造成事故或傷害時，本公司概不負責。

1. 重要事項

使用產品前請仔細閱讀本說明書，並妥善保管。

- 機器的安裝調試或維護保養必須由廠方授權人員實施，方可保障機器處於正常工作狀態。未經廠方授權人員安裝調試或維護保養，導致產品無法達到正常狀態或性能時，廠方不承擔責任。
- 電源元件與機器屬於耦合連接，若電源元件損壞，為了避免危險，必須由製造商、其維修部門或類似部門的專業人員更換。機器的維護保養、濾芯更換，需使用指定的原裝部件，使用非原裝部件或附件引起的問題，使用性能的降低或造成的財物的損壞均不包括在廠商有限擔保範圍之內。
- 非原裝濾芯可能會導致水質異常，帶來安全風險和影響機器壽命。
- 本家用智能潔淨廁板適用於家居生活環境，如用於商業用途，將會縮短本產品的使用壽命。
- 嚴禁安裝在室外。
- 產品安裝使用後，使用者應根據使用情況經常進行檢查和必要的維護，如有異常，應立即停止使用。
- 對本產品進行任何維護保養和維修前，請務必斷開電源。非本公司認可的專業人員不得調整和維修本產品。
- 任何部件如果被水浸泡，應由專業人員檢查或修理後方可使用。
- 請勿在本機上覆蓋東西。
- 請勿在本機上放重物。
- 下水道堵塞時請勿使用本機。



以上條款解釋權在法律允許下歸本公司所有。

2. 安全注意事項

- 使用之前，請仔細閱讀下列【安全注意事項】，以便進行正確使用。
- 下列注意事項如有使用不當，可能造成重大的意外事故。
- 下列內容均與安全密切相關，請您務必嚴格遵守。

 警告: 表示使用不當時，有可能造成使用者死亡或者重傷。

 注意: 表示使用不當時，有可能造成使用者輕傷或財物損壞。

		
與上述的“警告”、“注意”事項並用，以引起您足夠的注意。請您一定認真閱讀並嚴格遵守。	此符號表示是禁止此等操作。	此符號表示請按照指示操作。

警告



電源務必與帶接地的三孔電源插頭連接。

- 否則會成為觸電等的原因。



1. 清潔廁板本體或者進水管道漏水時，應立即拔下電源插頭，關閉進水角閥。

- 否則會有觸電、火災、室內積水的危險。

2. 在有可能發生內部積水凍結時，請務必採取防凍措施。

- 否則凍結內部積水引起的破損會導致火災和室內積水。

3. 長時間使用時，請將坐溫調整為【常溫檔】。

- 長時間使用【常溫檔】以外的溫度時，會有導致低溫燙傷的危險。

4. 插拔電源插頭時，應手握插頭本體進行。

- 如果手握電線部分進行拔插時，會有插頭或者電線破損，觸電或者火災的危險。



此圖片僅供參考

5. 電源插頭應定期從插座拔出，並用幹布擦拭。
 - 積存在電源插頭的灰塵會有導致火災的危險。
6. 電源插頭應全部插入。
 - 否則會有觸電、火災的危險。
7. 身體、感知或智力能力有缺陷或缺乏經驗和常識的人（如下列人員）使用時，請陪伴者將坐溫和水溫調整為【常溫檔】
 - 兒童
 - 老年人
 - 病人
 - 無法調節自身溫度者
 - 皮膚較弱者
 - 服用了安眠藥等催眠的藥物者
 - 飲酒過量者
 - 極度疲勞者

禁止



1. 產品有裂痕或者破損時，不要碰觸破損部位。
 - 否則會有受傷的危險。請聯繫銷售方或者售後服務進行修理。
2. – 請勿使用破損的插頭以及有問題的插座。
 - 請勿自行更換。
 - 如果電源軟線損壞，為避免危險，必須由其製造商授權的專業人員更換。
 - 否則可能會引發漏電、火災、受傷。
3. 請勿將電源線劃傷、破損、加工、強行彎曲、拉伸、擰緊、捆紮、壓放重物、縮短。
 - 否則電源線破損，會有觸電、火災的危險。
4. 為避免熱斷路器誤重設產生危險，本產品不能安裝在有外部開關裝置如有帶有計時器的插座。
 - 否則漏電斷路器無法正常動作，可能導致火災

5. – 請勿使用AC220V以外的電壓。

– 請勿使電路超載。

- 否則可能會引發火災。

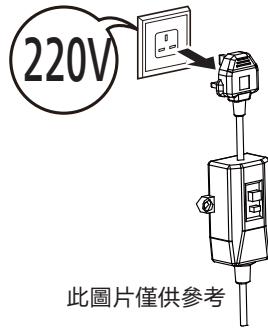

6. 禁止用水清洗機身、電源插頭。

- 可能引起故障或觸電。



1. 請使用產品附帶的安裝配件(舊軟管元件不能重複使用)。

- 否則會有漏水或無法安裝的情況。



禁止濕手碰觸

禁止用濕手插拔電源插頭。

- 否則有觸電的危險。



禁止拆卸

若產品出現故障，請立即關機並拔下電源線插頭，聯絡客戶服務中心跟進，絕對不能私自拆卸或者改造本產品。

- 否則可能會引發漏電、火災、受傷。



禁止沾水

智能潔淨廁板或者電源插頭應安裝在不會被水或者清潔劑潑灑到的位置。

- 否則會導致漏電、火災。



注意



1. 清潔保養塑膠部分時，請勿使用不適合的清潔劑。

- 如果使用廁所專用洗滌劑、住宅用洗滌劑、漂白劑、汽油、稀釋劑、去污粉、甲酚等，會有導致塑膠部破損，發生受傷、觸電、火災的危險。



2. 清潔時務必將電源插頭從插座拔下。
 - 否則會有觸電的危險。
3. 長期不使用時，應進行排水操作，並將電源插頭從插座拔出。
 - 否則會有凍結破損導致火災、室內積水的危險。
 - 否則會導致產品內部的水被污染，進而導致皮膚炎症的危險。
4. 以下人員使用時，請陪同人員注意防止其跌倒。（兒童、老年人、自己不能坐下或站起者）
 - 孩子不應該玩耍本產品，不要讓孩子單獨使用本產品。
 - 否則可能造成人身傷害或上蓋破損。
5. 在安裝本產品的房間中，需要在觸手可及的位置安裝一個止水閘，用於在緊急情況下，無需借助工具即可切斷本產品的進水水路，否則本產品的意外故障可能會導致使用者損失。
 - 否則緊急情況時發生漏水導致室內積水。



1. 請勿將進水軟管彎折、弄碎。
 - 否則會發生漏水導致室內積水。
2. 請勿用手碰觸、踩踏角閥。
 - 否則會發生漏水導致室內積水。
3. 請勿背靠在便蓋上。
 - 否則有可能造成便蓋劃傷和損傷的危險。



請勿將香煙及其它可燃物接近產品。

- 否則會有火災的危險。

3. 安裝前準備事項

部件標識

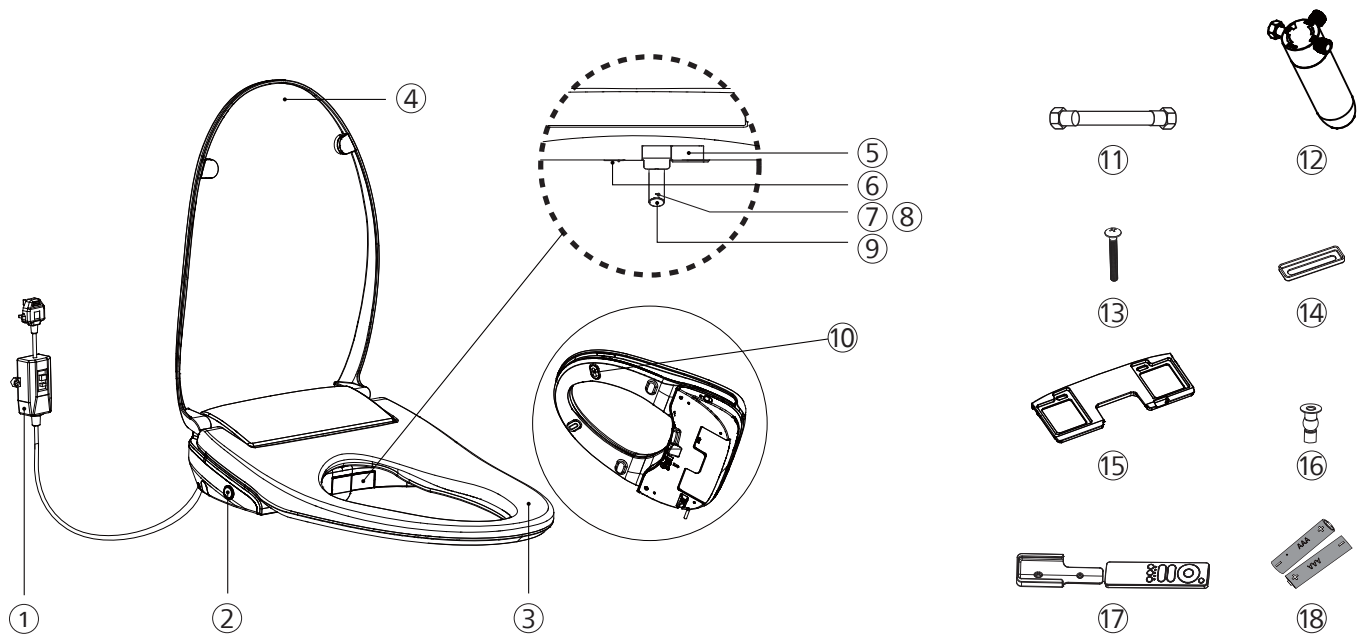

① 漏電保護插頭

② 側按鍵

③ 座圈

④ 座圈蓋

⑤ 暖風

⑥ 夜燈

⑦ 婦洗

⑧ 臀洗

⑨ 噴嘴

⑩ 座圈緩沖墊

⑪ 進水軟管

⑫ 過濾器

⑬ 螺釘

⑭ 調節片

⑮ 固定板

⑯ 膨脹螺母

⑰ 遙控器&遙控器支架

⑱ 電池

產品尺寸圖、準備工具

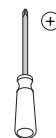
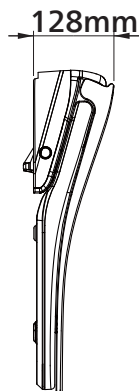
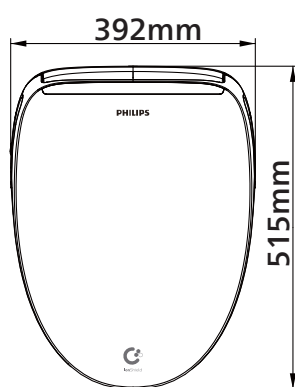

十字螺絲刀



活動扳手



鑽頭



捲尺



杯子



電鑽

電源、進水連接建議

注意：請在安裝本產品的同一房間中在觸手可及的位置安裝一個止水閥，用於緊急情況切斷本產品的水路，否則產品的意外故障可能會導致使用者財產損失。

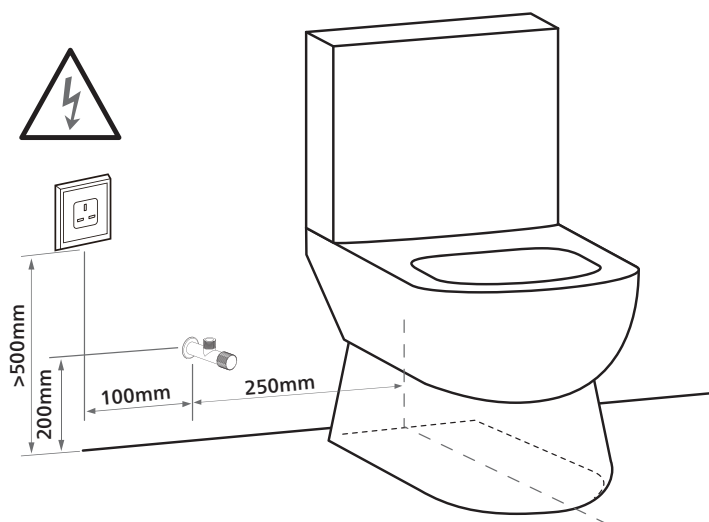

4. 裝箱清單

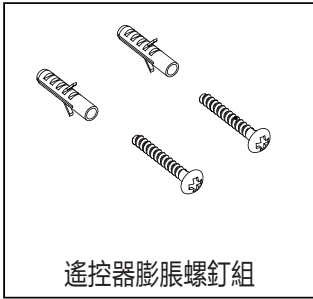
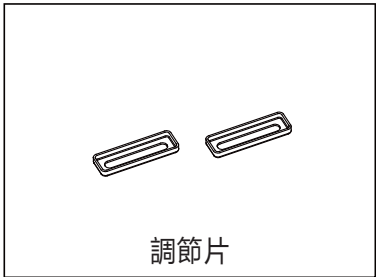
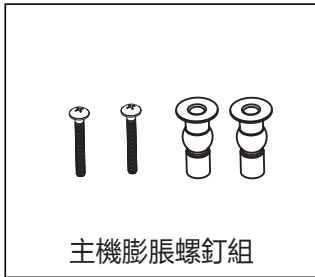
 <p>主機</p>	 <p>遙控器膨脹螺釘組</p>	 <p>固定板</p>	 <p>過濾器</p>
 <p>調節片</p>	 <p>進水軟管</p>	 <p>主機膨脹螺釘組</p>	 <p>遙控器與遙控器支架</p>
 <p>使用說明書</p>	 <p>遙控器電池 (AAA)</p>	 <p>漏電保護插頭膨脹螺釘組</p>	

清單

名稱	數量	備註
主機	1台	
固定板	1個	從產品底部取出
過濾器	1組	
調節片	2個	
進水軟管	1個	
主機膨脹螺釘組	2組	
遙控器與遙控器支架	1組	
使用說明書	1本	
遙控器電池（AAA）	2個	
遙控器膨脹螺釘組	2組	
漏電保護插頭膨脹螺釘組	1組	

5. 安裝步驟

本產品出廠前做過通水檢測，取出產品時可能會有少量殘留水滴出，並非故障。

1. 請先從主機取出固定板。

如圖所示，把膨脹螺母、固定板、螺釘、調節片依次裝入馬桶陶瓷安裝孔內預裝到七分緊。



2. 將潔淨廁板裝入安裝在陶瓷上的固定板試裝，調整好位置，再按住產品側面推杆拆下潔淨廁板，固定膨脹螺絲。



3. 將潔淨廁板底部對準固定板卡槽，沿水準方向推入，聽到“啞嗒”聲即可。

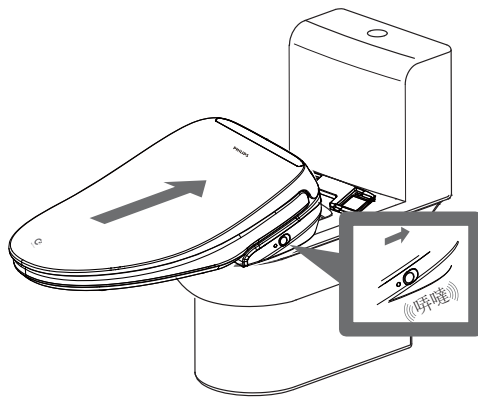

4. 注意：將各進水管接到過濾器正確位置。

將過濾器接角閘上，
並接上兩根水管。

原馬桶淡水進水管
(如適用)

過濾器

廁板淡水進水軟管

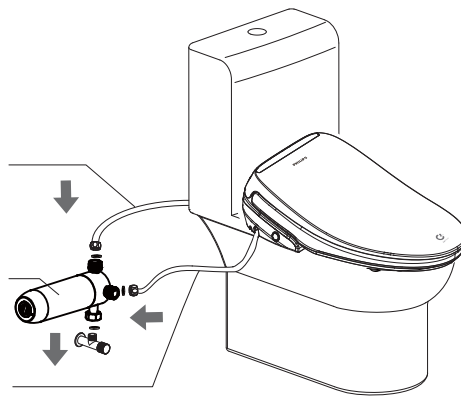

5. 安裝遙控器

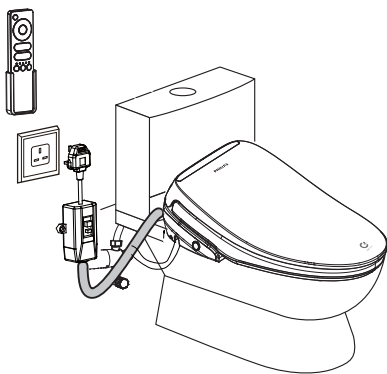

向上滑動，拔出遙控器。
向下滑動，放回遙控器。

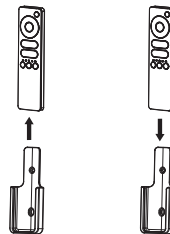

A. 根據圖示位置尺寸，在牆上合適位置鑽兩個直徑為4.5mm的孔，
深度>20mm。

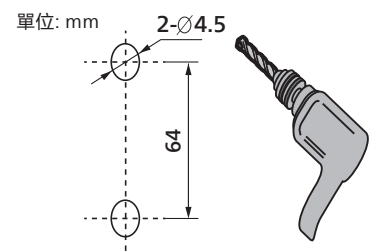

B. 將配件包內的膨脹螺母裝入鑽好的孔內。

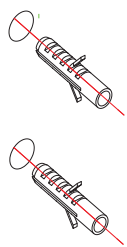

C. 用膨脹螺釘固好遙控器支架。

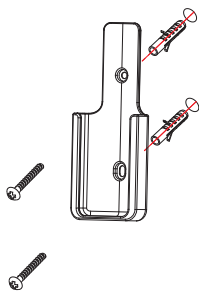

D. 電池安裝

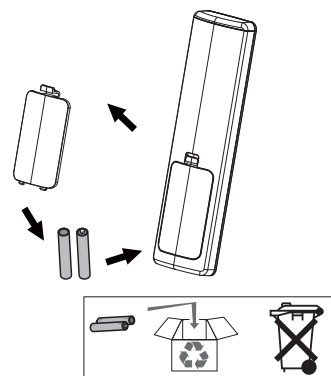

6. 連接水源

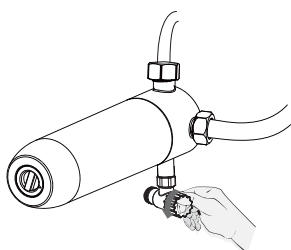

打開角閥開關

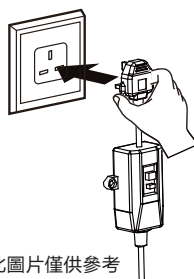

7. 連接電源

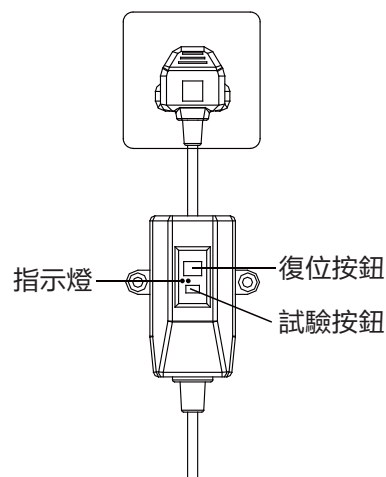

此圖片僅供參考



漏電保護測試

- (1) 正常狀態下，按下電源插頭上的“”按鈕，插頭指示燈亮綠色，產品通電開始初始化，進入待機狀態；
- (2) 按下“”按鈕，指示燈關閉，產品斷電；
- (3) 再按下電源插頭上的“”按鈕，指示燈亮綠色，產品恢復供電。

⚠ 警告

- 當電源開關無法正常工作時，請檢查是否有任何漏電情況發生。
- 漏電保護插頭僅保護通過該插頭與電源連接的產品，使用其它電器裝置時，該產品不能保證其它產品的漏電保護；同樣，該產品不能替代其它電器基本安全措施。
- 切記勿將火線直接接地來試驗該產品插頭的漏電保護功能。

8. 功能試運行

試運行

用手輕按人體感應位置，同時按臀洗/婦洗按鍵，
檢查噴嘴是否正常工作。

請用杯子擋在噴嘴出水口防止水濺身上或地板上。

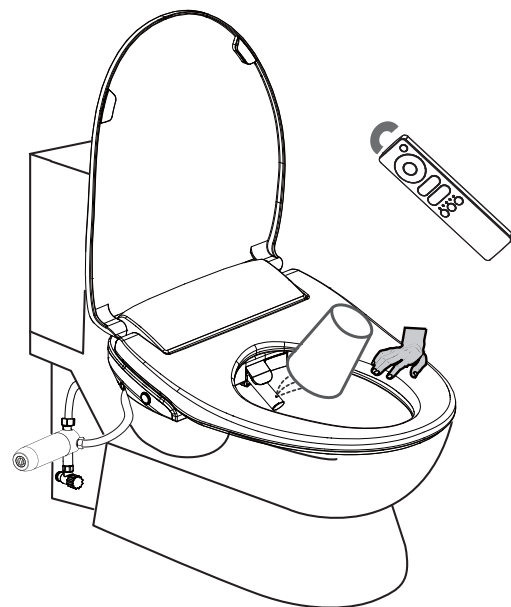

9. 漏電保護插頭固定

A. 根據圖示位置尺寸，在牆上合適位置鑽兩個直徑為4.5mm的孔，深度>20mm。

單位: mm

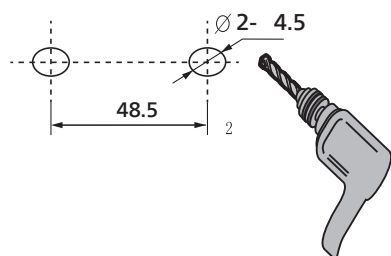

B. 將配件包內的膨脹螺母裝入鑽好的孔內。

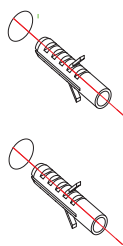

C. 用膨脹螺釘固定好漏電保護插頭。

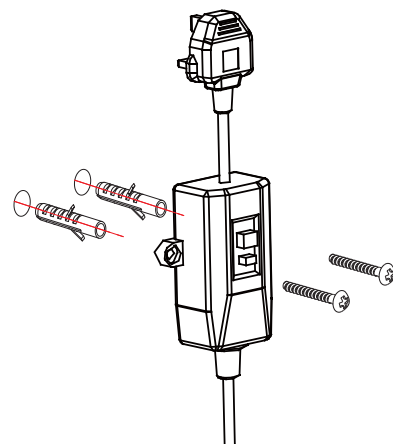

6. 主要技術規格

	名稱	智能潔淨廁板
		型號
清洗	臀洗	●
	婦洗	●
	兒童清洗	●
	移動清洗	●
	水壓控制	5檔設定
	水溫控制	5檔設定+常溫檔
	噴嘴位置調節	5檔設定
暖風	暖風	●
	暖風溫度控制	3檔設定+常溫檔
座圈和上蓋	座圈加熱控制	5檔設定+常溫檔
	座圈抗菌	●
	座圈和上蓋緩降控制	●
感應器	座圈使用感應器	●
清潔衛生	噴嘴抗菌	●
	噴嘴自動清潔	●
其它	夜燈	●
節能	節電設置	●
額定電壓		220V~
額定頻率		50Hz
額定功率		820W
最大輸入功率		1050W
環境溫度		0°C~40°C
供水壓力		0.07MPa~0.75MPa
供水溫度		3°C~35°C
防水等級		IPX4
衝洗流量		約250~550ml/min(水壓0.2MPa時)
熱水	水溫	常溫 ~41°C
	加熱器功率	1000W
加熱座圈	表面溫度	室溫 ~41°C
	加熱器功率	50W
暖風	暖風溫度	室溫 ~60°C
	風速	≥4m/s
	暖風功率	250W
殺菌	方法	納米水離子
尺寸		515X392X128mm

說明

額定功率:

本產品在環境溫度 $23^{\circ}\text{C}\pm 2^{\circ}\text{C}$ ，進水靜壓 $0.2\text{MPa}\pm 0.02\text{MPa}$ ，進水溫度 $15^{\circ}\text{C}\pm 0.5^{\circ}\text{C}$ 條件下，開啟臀洗功能並依次將流量調到最大，座溫、水溫設置為最高檔，按停止後再立即開啟臀洗並完整工作一個清洗週期的平均功率。

最大輸入功率:

本產品在環境溫度 $23^{\circ}\text{C}\pm 2^{\circ}\text{C}$ ，進水靜壓 $0.2\text{MPa}\pm 0.02\text{MPa}$ ，進水溫度 $5^{\circ}\text{C}\pm 1^{\circ}\text{C}$ 條件下，依次將流量調到最大，座溫、水溫設置為最高檔後，立即開啟臀洗並完整工作一個清洗週期的平均功率。

最佳清潔性能說明:

本產品如要獲得最大潔淨效果，需將水壓、水溫調到最高檔後，開啟臀洗功能，調整噴嘴位置到最前端，清洗1分鐘後，調整噴嘴位置到最後端，直至沖洗週期結束。

7. 側面按鍵概述

因本產品設計時以遙控器控制為主，所以，側按鍵只有常用基本功能，如下圖所示。

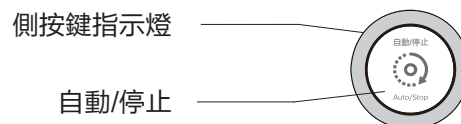

說明:

側按鍵包含自動臀洗和自動婦洗兩種功能:

著座時，單擊啟動全自動臀洗功能：臀洗+移動+臀洗+暖風；

著座時，長按3秒後啟動全自動婦洗功能：婦洗+移動+婦洗+暖風；



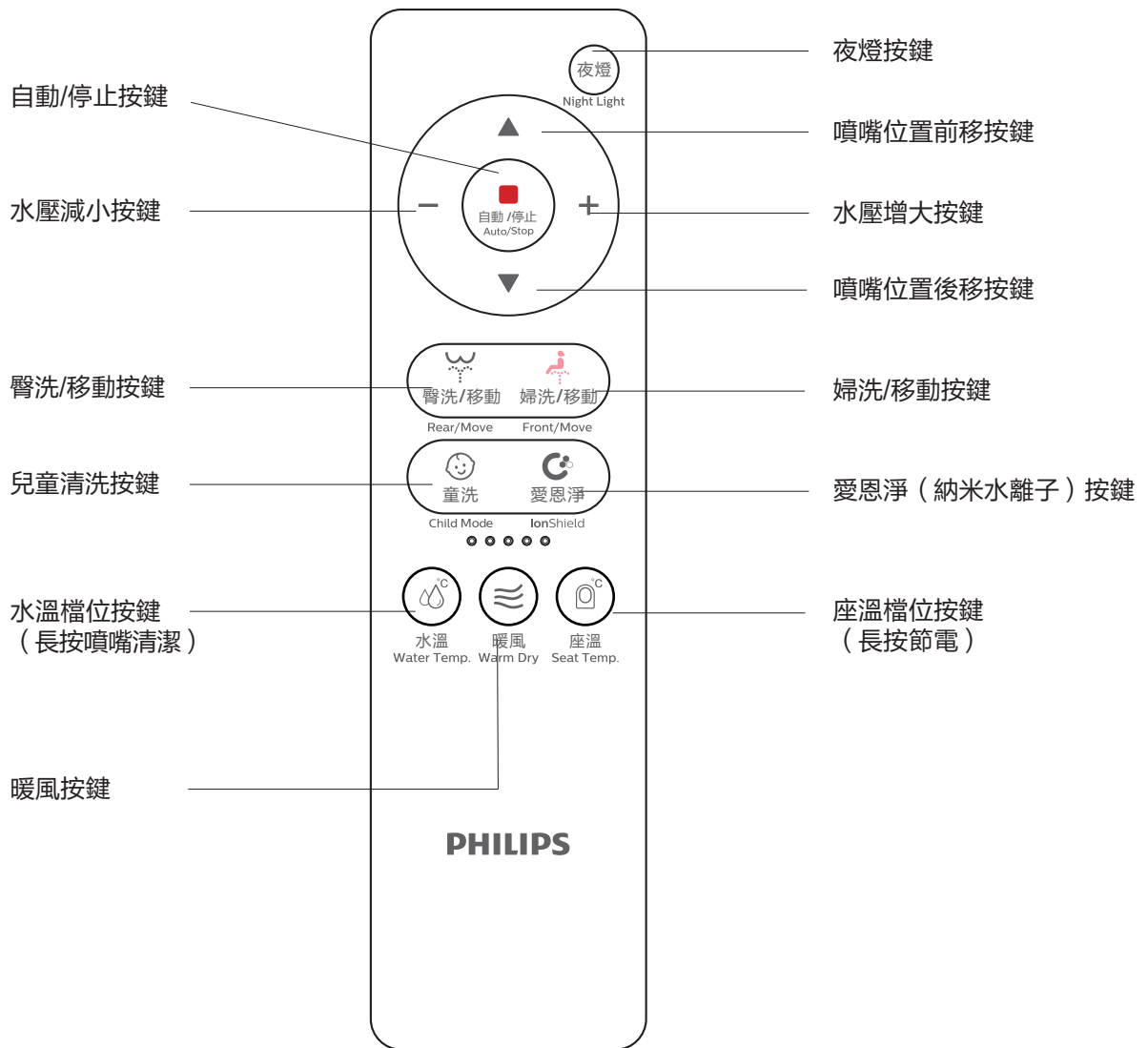

離座時，長按（10秒以上）本機側按鍵，所有功能關閉，蜂鳴器響三聲，指示燈熄滅，進入待機狀態；此時按任意按鍵或著座時，退出待機模式；

8. 遙控器版面概述







9. 使用方法

1. 臀洗/移動

著坐狀態下，按“”按鍵，進入臀洗模式，噴嘴伸出後先固定位置清洗，然後會進行移動清洗，再恢復固定位置清洗，臀洗約3分鐘後自動停止，或按“”按鍵停止工作；在此模式下，可按“”按鍵進入移動清洗，再按“”按鍵停止移動清洗。



2. 婦洗/移動

著坐狀態下，按“”按鍵，進入女性清洗模式，噴嘴伸出後先固定位置清洗，然後會進行移動清洗，再恢復固定位置清洗，約3分鐘後自動停止，或按“”按鍵停止工作；在此模式下，可按“”按鍵進入移動清洗，再按“”停止移動清洗。

3. 兒童清洗



著坐狀態下，短按“”開啟兒童清洗，首先水壓、水溫、風溫切換到最低檔臀洗1分鐘，然後自動開啟暖風2分鐘，結束後恢復之前的水壓、水溫、風溫。

4. 水溫設定

按“”鍵（在沖洗模式下），指示燈顯示水溫檔位；再按下“”鍵，可循環切換水溫度檔位，指示燈顯示如下圖所示：





5. 水壓調節

在臀洗/女性清洗模式下，每按“”按鍵一次，水壓增加一檔，總共五檔；每按“”按鍵一次，水壓減少一檔，總共五檔可調。





6. 噴嘴位置調節

在臀洗/女性清洗模式下，按“”按鍵，噴嘴前移；按“”按鍵噴嘴後移，總共五檔可調。

7. 噴嘴清潔



離坐狀態下，長按“”噴嘴自動伸出清洗約2分鐘，再次操作噴嘴縮回並自潔。

8. 座溫設定



按“”鍵，指示燈顯示座圈溫度檔位；再按下“”鍵，可循環切換座圈溫度檔位，指示燈顯示如下圖所示：



9. 夜燈模式

按“”按鍵，夜燈開啟，再按“”按鍵，夜燈熄滅。

10. 暖風設定

– 著坐狀態下，按“”鍵，啟動暖風功能；約5分鐘或離坐後自動停止，或按“”鍵停止。

– 暖風模式下，再按下“”鍵；可循環切換風溫檔位，如下圖所示：



11. 節電模式

長按“”開啓或關閉節電模式；

12. 自動/停止

– 在著坐未使用其他功能狀態下，按遙控器的“”鍵，進入全自動工作模式，工作步驟如下：臀洗→移動按摩清洗→臀洗→暖風→停止；

– 產品功能使用狀態下，短按按鍵，停止該功能。

13. 納米水離子殺菌

– 離坐狀態下，按“”按鍵操作進入納米水離子殺菌功能，短按工作1小時，長按(≥3秒)工作2個小時。

– 當開啟納米水離子功能後，側按鍵上光圈顯示為強弱的呼吸效果；

– 短按光圈為藍色呼吸燈效果，長按光圈為紫色呼吸燈效果；納米水離子功能執行期間，燈按照上述邏輯一直亮著，直到功能完成或被停止。

– 進入納米水離子殺菌功能後，若進行長按/短按切換殺菌時間，工作時間將會重置。

– 納米離子殺菌功能工作期間，按“”或著坐自動退出納米水離子殺菌功能。

10. 維護保養

清潔保養本產品時，請先拔出電源插頭，關閉角閥開關，切斷電源以免發生漏水、觸電等危險。

潔淨廁板清潔

1. 拔出電源、關閉角閥

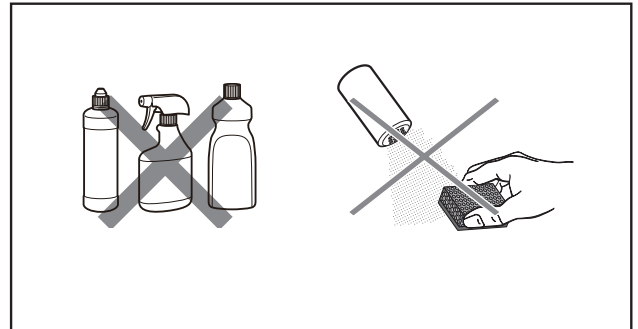
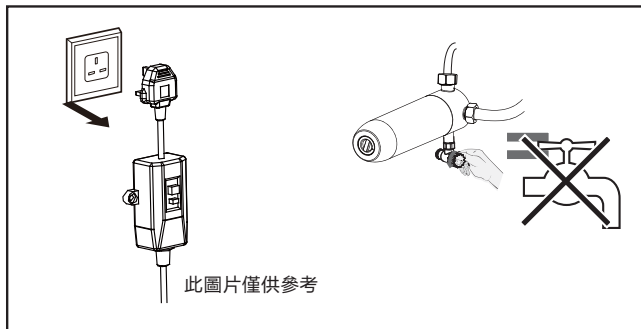

2. 清潔潔淨廁板

用軟布加清水擦拭（要擰乾）

注意事項：

- 本產品為塑膠產品，請勿用乾布或衛生紙等清潔，否則可能劃傷產品。
- 產品內部有電子元器件，請注意避免水滲入內部，否則可能導致產品功能性的故障。
- 遙控器發射處與接收處要時刻保持清潔。

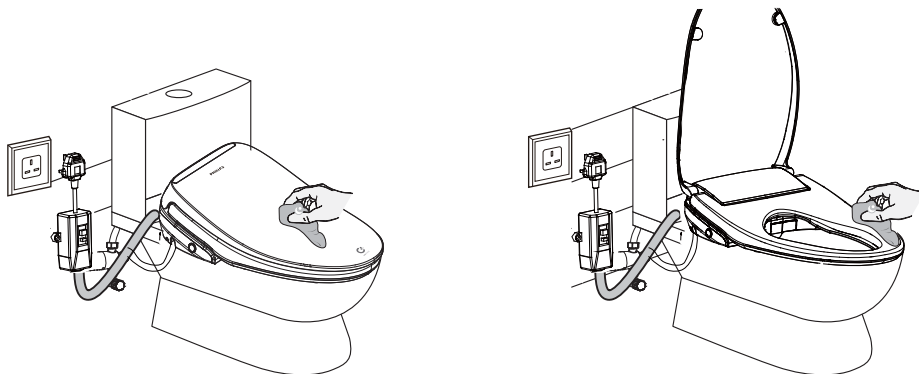

3. 拆下潔淨廁板

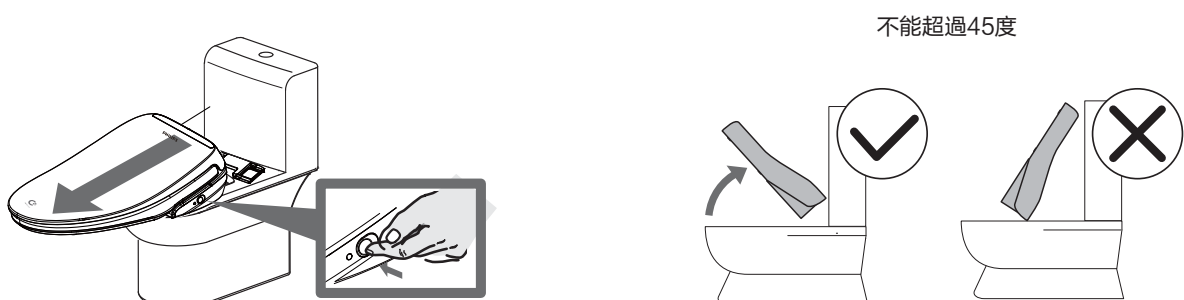

4. 清潔潔淨廁板和陶瓷

拆下潔淨廁板本體後，可以清潔潔淨廁板左右兩側和底部，還有陶瓷面四周。

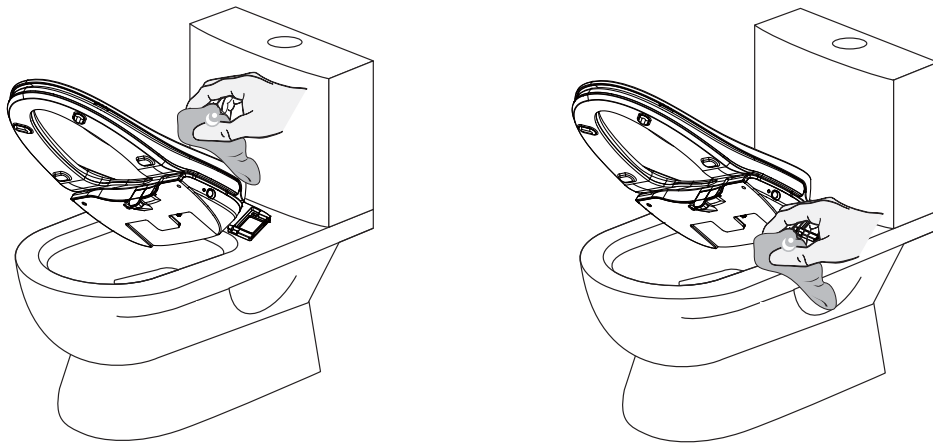

噴嘴清潔

離坐狀態下，長按“”鍵，噴嘴伸出後，戴上橡膠手套，拆下噴嘴用牙刷等清潔。

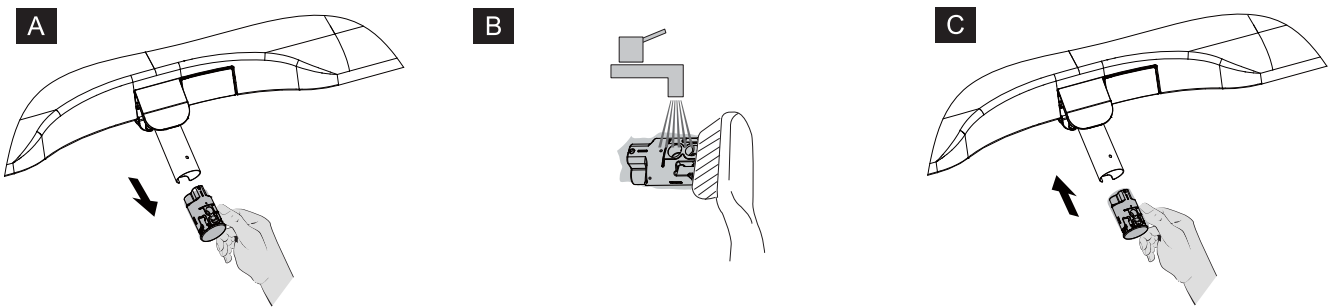

更換過濾器濾芯

- 建議使用6個月後，更換一次濾芯（具體使用週期依水質而定）。

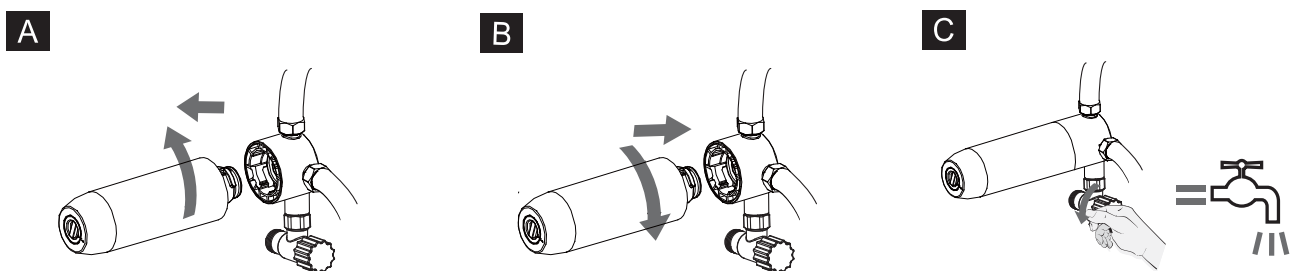

先關閉水源，然後擰開並取下過濾器濾芯。

裝上新過濾器濾芯。

打開水源。

11. 長閒置期處理方式

當遇到如下兩種情況時：

- 長時間（一周以上）不使用。
- 室溫低於0℃，為防止產品凍裂。

請按以下步驟將產品管路內的水排光：

第一步：擰緊供水閥門，切斷水源。

第二步：長按“”鍵，進行內部排水。

第三步：拔出電源線插頭。

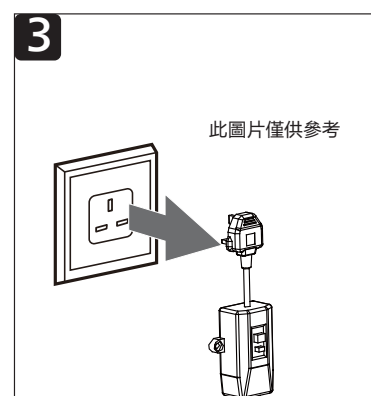
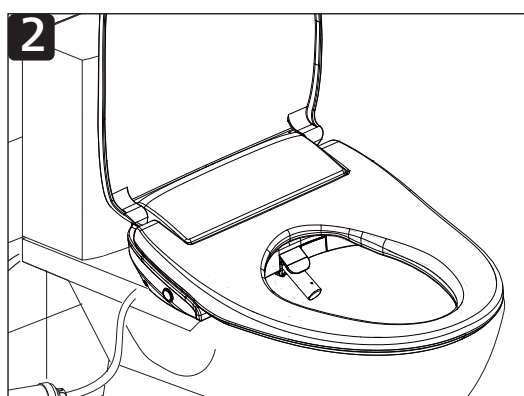
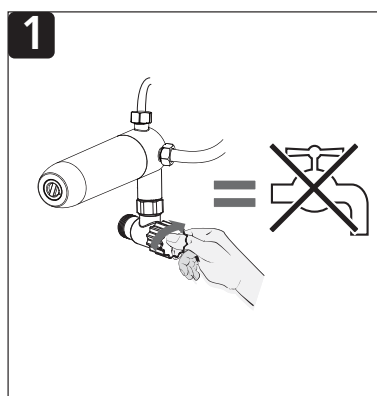

12. SIAA抗菌認證說明

產品坐圈材質是經過SIAA抗菌協會認證的，能夠有效抑制大腸桿菌、金黃色葡萄球菌繁殖，抗菌率99.9%

無機銀
抗菌劑

MICROKILLER®

混合·座圈

CN0122781A00010

13. 故障診斷

現象		原因	解決方法
產品無法正常工作		電源關閉	開啟電源。
夜光燈功能	夜光燈關閉	夜光燈設定成“關閉”狀態。	按“夜燈”按鍵開啟夜光燈。
	夜光燈開啟	夜光燈設定成“開啟”狀態。	按“夜燈”按鍵關閉夜光燈。
噴嘴清潔模式	噴嘴自動縮回	噴嘴清潔約2分鐘後噴嘴自動縮回。	這是正常現象。
	長按水溫按鍵，噴嘴不伸出	座圈上有導電介質，例如：水滴或濕紙巾等，感應器將識別成使用者。	把座圈上的導電介質拿走。
婦洗/ 臀洗/ 童洗	噴嘴伸出太緩慢	啟動婦洗或臀洗功能時，噴嘴會在出口處自動清洗後再伸出運作，該操作需耗時幾秒鐘。	這是正常現象。
	低水壓	水壓是否設定成較低模式。	按“水壓”鍵將水壓調至合適的檔位。
		過濾網/過濾器堵塞。	清洗過濾網或更換過濾器濾芯。
		供水軟管連接螺母鬆動。 軟管漏水。	擰緊螺母。
	低水溫	水溫設定成較低或常溫檔。	按“水溫”鍵將水溫調至合適的檔位。
	噴嘴突然停止噴水	清洗約3分鐘後噴嘴停止噴水，自動縮回。	這是正常現象。
座圈加熱	使用過程中座圈溫度不夠高。	座溫設置成較低或常溫檔。	將座圈溫度調至合適的檔位。
	座圈溫度過高	座溫設置成較高檔位。	將座圈溫度調至合適的檔位。
暖風功能	暖風溫度不夠	暖風溫度設置為常溫檔。	在暖風狀態下將暖風溫度調至合適的檔位。
	暖風無法正常工作	啟動了其他清洗功能。	關閉所有清洗功能，然後啟動暖風。
	暖風功能突然停止	使用者突然離開座圈，感應器無法探測到使用者。	請坐回座圈上，並啟動暖風功能。

按鍵指示燈與警報功能	按鍵指示燈亮紅色，一次閃兩下。	水溫過高，自潔口不斷出水。	1.將水溫設定為常溫，等待時間約20秒，重新開啟電源。 2.不能排除時，停止使用，聯繫客戶服務中心。
	側按鍵指示燈亮紅色，一次閃一下。	進水沒有打開。	打開進水，重新開啟電源。
	側按鍵指示燈亮藍色，一次閃一下。	座溫故障。	切斷電源，停止使用產品，聯繫客戶服務中心。
	側按鍵指示燈亮紅色，一次閃四下。	水相關感測器故障。	
	側按鍵指示燈亮藍色，一次閃三下。	座圈感測器故障。	
	電源插頭漏電保護開關時常跳閘。	產品漏電。	
遙控器	遙控器無法正常工作。	電池電量用盡。	更換新電池。
		電池正極和負極設置不正確。	正確設置電池正極和負極。
	遙控器按鍵不靈敏。	電池電量低。	更換新電池。
		遙控器是否距離產品太遠，或不在感應範圍內？	請在有效感應範圍內使用遙控器。

14. 環保清單

根據中華人民共和國《電器電子產品有害物質限制使用管理辦法》的相關規定和要求，提供如下包括電子產品名稱及有害物質的樣式。

有害物質

部件名稱	鉛 (Pb)	汞 (Hg)	鎘 (Cd)	六價鉻 (Cr (VI))	多溴聯苯 (PBB)	多溴苯醚 (PBDE)
電源纜組件	○	○	○	○	○	○
外殼塑料件	○	○	○	○	○	○
內部塑料件	○	○	○	○	○	○
內部軟管	○	○	○	○	○	○
內部五金件	○	○	○	○	○	○
內部電器件	×	○	○	○	○	○
電路板	×	○	○	○	○	○
三通組件	×	○	○	○	○	○

本表格依據SJ/T11364的規定編制。



○：表示該有害物質在該部件所有均質材料中的含量均在GB/T26572 標準規定限量要求以下。
 ×：表示該有害物質至少在該部件某一均質材料中的含量超出GB/T26572標準規定的限量要求。
 上述“×”標識的部品現階段沒有可替代的技術和部件，且符合國家《電器電子產品有害物質限制使用管理辦法》的法規要求。

產品回收處理提示說明：

為保護環境，依照國家《廢棄電器電子產品回收處理條例》的有關規定，使用者不再需要此產品或產品壽命終止時，請用戶將其送至有廢棄電子產品處理資格的回收站回收處理。

15. 產品保修服務指南

從購買日期起，產品擁有兩年保固期。如果您需要更多資訊，

請瀏覽網站: www.philips.com/welcome

- 在購買日期後起計兩年內，凡經製造商認可人員確認為正常使用情況下，因製作工藝或原配件造成之損壞，您都將獲得免費保修服務。
- 此免費服務不包括需時常更換的易耗零配件（前置濾芯、噴嘴等）、輔助裝置、運輸費及維修人員上門服務費。
- 維修時請攜同購買憑證正本方為有效。

以下情況將不能獲得免費服務

1. 使用不當引起的人為損壞，例如接入不適當配件、不適當之安裝、不依說明書使用、錯誤使用或疏忽而造成損壞等。
2. 因運輸及其他意外而造成之損壞。
3. 非經本公司認可之維修和改裝。
4. 其他因不可抗力（如自然災害、電壓異常等）造成的損壞。
5. 一般家庭以外使用（如工業、商業用等）而造成的損壞。
6. 正常使用引起的產品老化，磨損等，但不影響產品的正常使用。

該說明作為在規定期限及條件之內進行免費維修的宣傳，並不限制消費者的法定權利。

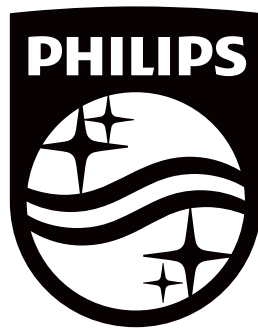

Register your product and learn more in the website link below:
www.philips.com/welcome

Specifications are subject to change without notice

© 2021 AquaShield

All rights reserved.

The Philips trademark and the Philips Shield Emblem are registered trademarks of Koninklijke Philips N.V. used under license.

This product has been manufactured by and is sold under the responsibility of Hong Kong AquaShield Health Technology Company Limited and Hong Kong AquaShield Health Technology Company Limited is the warrantor in relation to this product.

Rev A NOV 21

