

**PHILIPS**

RO Dispenser

ADD6915DG



**User Manual** 1-9

**使用説明書** 10-18



## CONTENTS

---

1 Product introduction 1

---

2 Main technical specifications 1

---

3 Product overview 2

---

4 User interface 2

---

5 Installation 3

---

6 Usage instruction 3

---

7 Precautions 5

---

8 Routine maintenance 6

---

---

9 Filter cartridge change 7

---

10 Trouble shooting 8

---

11 Guarantee & Service 9

---

12 Packing list 9

---

# 1 Product introduction

This is a countertop RO water dispenser. With instant heating technology, it provides hot water of different temperatures within seconds. The innovative AquaShield all-in-one RO filtration system removes 110 kinds of harmful substances that may exist in the tap water\*.

\*The removal rate of 101 substances are tested by international certification and testing agency SGS/BV under laboratory conditions, and other 9 substances are tested by internal laboratory.

# 2 Main technical specifications

Product model	ADD6915DG
Rated voltage	220 V – 240 V ~
Rated frequency	50/60Hz
Rated Power Consumption	2300 W
Filter cartridge total rated water purification amount	2000 L
Applicable water source	Municipal tap water
Inlet water pressure	0 – 0.06 MPa
Inlet water temperature	5 – 38°C
Water filtration flow rate	0.13 L/min(25°C)

### 3 Product overview

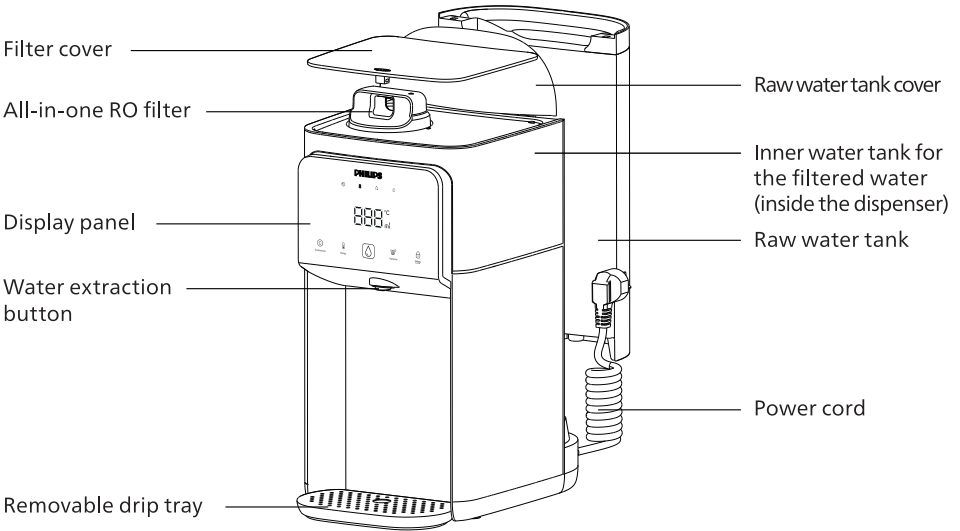

### 4 User interface

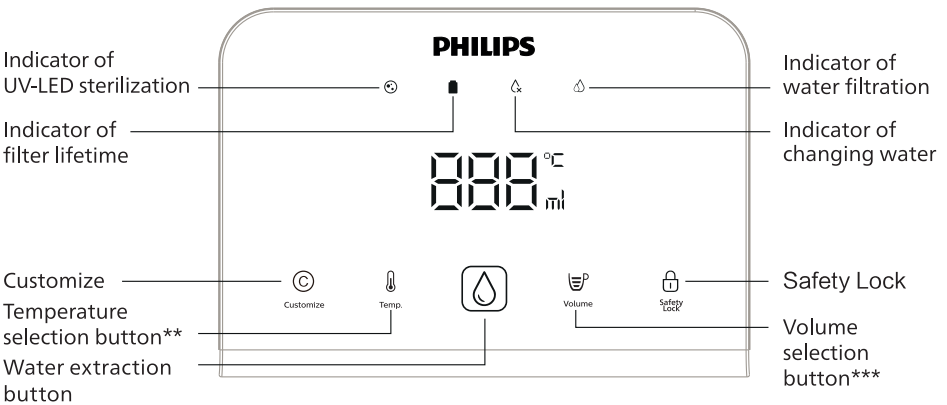

\*\*There could be a temperature deviation of  $\pm 3^{\circ}\text{C}$ . \*\*\*There could be a volume deviation of  $\pm 10\%$ . The actual temperature and volume depends on usage environment and local tap water quality.

# 5 Installation

## (1) Setup

- Please put the dispenser on a cool, well-ventilated and stable place. Keep away from heat.
- Take out the raw water tank and fill it with water. Install it back to the dispenser and cover the lid.
- Plug in. The dispenser beeps and icons on display panel will be on once it has been set up.

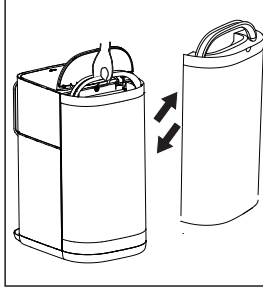
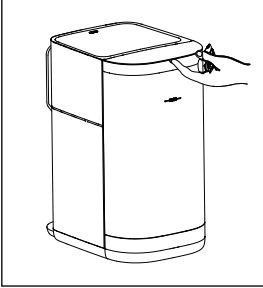

## (2) First time using

- During first time use, please check if any water leaks from or gathers around the dispenser, if there is any strange noise, burnt smell or smoke coming out from the product, please disconnect the power cord and contact customer services if you find any of the situations above.
- For the first time use, or if the dispenser has not been used for a long time, fill the water tank and wait until the filtering indicator is off. Continuously extract the water until the water tank is empty by pressing "⌚" (Temp. button) and "☞" (Volume button) for 3 seconds. Repeat this twice.
- Note: When the dispenser starts to heat up the water, in order to avoid dry-heating and protect the machine, please extract some ambient water before choosing hot water.

# 6 Usage instruction

## (1) Filtering water

- If the inner water tank for the filtered water is at a low water level, the dispenser will automatically start to filter the raw water until the filtration is done. When the "△" (Indicator of water filtration) is on, water can still be extracted. When the "△" (Indicator of water filtration) flashes, water cannot be extracted.

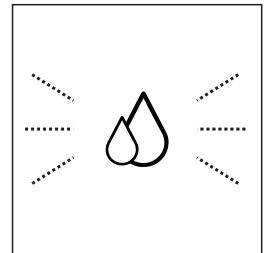

## (2) Extracting water

- Select the water temperature and volume needed. Press the "🔒" (Safety Lock button) to unlock. This step is not needed if ambient water is selected. Tap the extraction button once to get the water you choose. Tap it again or tap any other button to stop.
- Continuous water extraction: long press the water extraction button for 3 seconds to continuously extract water.
- Note: To avoid being scalded, keep the distance from the nozzle during extracting hot water.

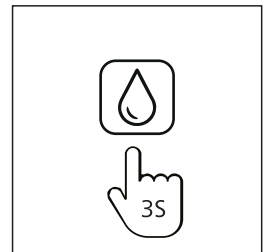

- Customization: If the extraction process is stopped in halfway, press the "Ⓢ" (Customize button) and the dispenser will memorize the water temperature and volume extracted at this time. The dispenser will go back to standby mode if no button is pressed within 10 seconds. Next time if you want to extract water of the customized temperature and volume as originally selected, press the "Ⓢ" (Customize button) and then the "🔒" (Safety Lock button) to unlock (this step is not needed if ambient water is selected), the dispenser will extract the customized water when you press the extraction button.
- The extraction indicator light will be on when extracting water.

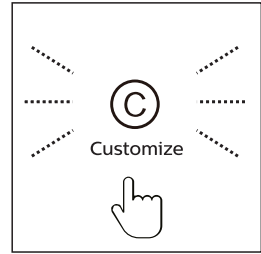

### (3) Changing water

- When "Ⓢ" (Indicator of changing water) flashes, the water in the raw water tank needs to be changed, which will happen in the following conditions;
- Water in the raw water tank is at or less than the lowest water level;
- TDS value in the tank is high;
- Water in the tank is not changed for over 48 hours.

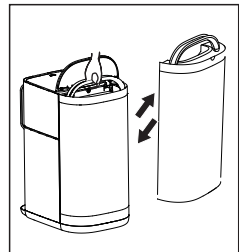
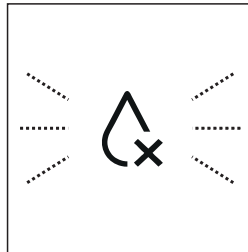

Empty and refill the raw water tank in these cases.

- Note: Never refill the raw water tank before emptying it. Cover the raw water tank lid after changing the water.

### (4) Rinsing

- The dispenser will do auto rinsing before and after water filtration once it is connected with power supply and the raw water tank is covered.
- Forced rinsing: long press "Ⓢ" (Temp. button) + "🔒" (Safety Lock button) for 3 seconds, the dispenser will rinse for 3 minutes. Forced rinsing cannot be performed when the inner water tank for the filtered water is full.

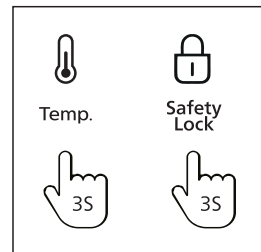

### (5) Emptying the inner water tank for the filtered water

- Long press "Ⓢ" (Temp. button) + "🍵" (Volume button) for 3 seconds. The dispenser will extract water until the inner water tank for the filtered water is empty.
- Note: Please prepare a container larger than 2L for the discharged water.

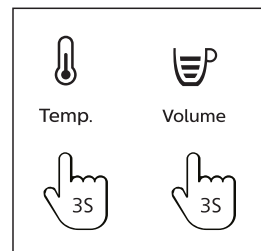

### (6) Winter mode

- When the raw water temperature is lower than 10°C, winter mode can be set.
- Long press “” (Temp.button) for 3 seconds, and then tap the water extraction icon to get 25°C filtered water, and this operation is only valid for a single use.

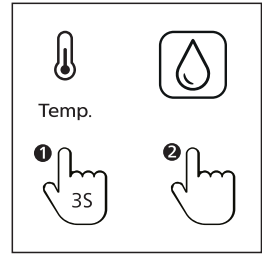

### (7) Sterilization

- The UV-LED sterilization will start to work for an hour once the dispenser is plugged in.
- Automatic sterilization: Each time the raw water filtration is completed, it will automatically sterilize for 10 minutes, then UV-LED will be on for 10 minutes in every 50 minutes.
- “” (Indicator of UV-LED sterilization) will light up during UV-LED sterilization, otherwise it will be off.

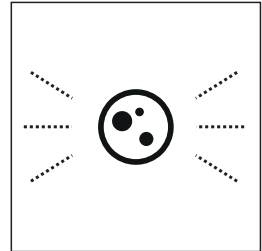

### (8) Sleep mode

- If no operation in 1 minute, the dispenser will automatically go to sleep mode.
- When the dispenser is in sleep mode, the lights of all buttons are off except the “” (Safety Lock button), displays “0” on the display panel.
- Touch any button to end the sleep mode.

## 7 Precautions

### Warning

- Use municipal tap water as the source. Do not use any water of unknown source.
- Keep the dispenser away from children.
- Be sure to handle the dispenser gently and carefully. Do not modify or drop the filter cartridge. If it has been modified, externally damaged or dropped, replace it.
- This dispenser is intended for domestic use only.

### Cautions

- Handle it gently to avoid damage.
- This dispenser should be placed on a stable and horizontal surface.



- The dispenser should be placed in a cool and well-ventilated indoor environment. Keep away from direct sunlight, heating elements, or hot surface.
- The dispenser shall not be placed in an environment that may have inflammable gas leakage.
- To avoid electric shock, do not touch the power plug with wet hands.
- To avoid damage, do not disassemble or modify the machine, or put any heavy objects on it.
- If the dispenser will not be used for a long time, please make sure it is disconnected from the power supply, and empty the water tank.
- The inlet water temperature should be 5°C-38°C. If the temperature is higher than 38°C, the filter cartridge will be damaged and unable to work. If the temperature is lower than 5°C, the dispenser might be frozen and the elements of the dispenser will be damaged.
- The dispenser can only be installed and used indoor, and with power supply of reliable grounding.
- For the first time use, or if the machine hasn't been used for a long time, fill the water tank and wait until the filtering indicator is off. Continuously extract the water until the filtered water tank is empty by pressing the temperature selection button and volume selection button for 3 seconds. Repeat this twice.
- Always use certified elements and accessories for the repairment and maintenance of the dispenser.
- Organic solvent such as gasoline shall not be used for wiping the housing of the dispenser. If cleaning is required, please gently wipe the surface of the product with wet cloth after it is disconnected from power supply.
- If there is any abnormality, unplug the product from power supply immediately, and do not leave the defective dispenser in working mode.
- With upgrade of the product, certain words or pictures on the manual may be different from the actual product, and the actual product shall govern in this case.
- The dispenser is suggested to be used in areas whose altitude are no higher than 1,200 m.
- If the user intends to extract ambient water or water of 45°C immediately after extracting hot water, some hot water may come out at the beginning, if so please watch out to avoid being burnt by the hot water.
- If the power cord appears to be damaged, please stop using the product. To avoid risks of danger, the power cord must be replaced by the manufacturer.
- Do not disassemble or repair the dispenser by yourself, nor hand it over to any person not authorized to repair, as improper repairing may cause risks of danger.

## 8 Routine maintenance

- (1) If the product is not used for over two days, it is suggested to change water in the raw water tank and then empty the inner water tank for the filtered water (Long press " ⏸ " (Temp. button) + " ⏸ " (Volume button) for 3 seconds). Repeat the process twice.
- (2) If the product will not be used for around or more than one week, please empty the water in it and disconnect the dispenser from power supply. Seal the filter cartridge and store it in the refrigerator (2-5°C, do not put it in the freezer). When you use it again, please follow the procedures above-mentioned to clean both water tanks.

### (3) Cleaning of raw water tank

If there are obvious impurities at the bottom of the raw water tank, please rinse it with water and clean it with the cleaning brush provided. Clean the raw water tank with the brush at least once per week.

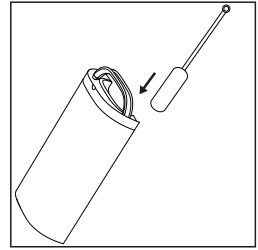

## 9 Filter cartridge replacement

Please change the filter cartridge according to the filter lifetime indicator on the display panel, or the suggested replacement cycle. New filter cartridge can be purchased from authorized retailers and service centers. The model code is ADD550.

Name	Model	Suggested Replacement Cycle
All-in-one RO filter (AquaShield)	ADD550	1 year

Only the original Philips filter cartridge can be used for replacement.

### (1) Indicator of filter lifetime

The color of "■" (Indicator of filter lifetime) shows the remaining lifetime for the filter cartridge as follows:

Blue: more than 10% lifetime left

Purple: less than 10% lifetime left

Red: less than 7-day lifetime left

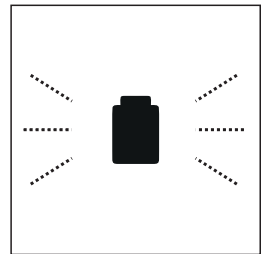

### (2) Filter cartridge replacement instruction

- Unplug the product from power supply;
- Press the button on the cover of filter cartridge and the cover will pop up;
- Rotate the old filter cartridge counterclockwise to the unlocked position and take it out;
- Insert the new filter cartridge into the dispenser. Rotate it clockwise to the locking position and cover the lid;
- Plug in. Long press "⏸" (Safety Lock button) + "🔊" (Volume button) for 3 seconds to reset the filter cartridge lifetime. The indicator light changes to blue again.
- Rinse the filter cartridge same as the first-time use.

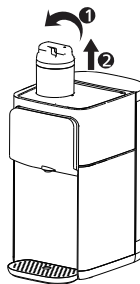
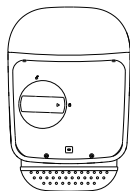

Take out

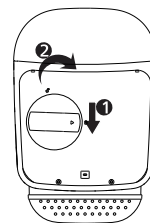

Install

# 10 Trouble shooting

Error	Causes	Solutions
Cannot extract ambient water	The product is not connected with the power supply	Check if the dispenser is well connected with power supply
	Button is not pressed properly	Press the water extraction button again
	Not enough filtered water in the inner water tank	If the "Δ" (Indicator of changing water) flashes, please change the water in the raw water tank. Extract water after filtration finishes
Cannot extract hot water	The dispenser is dry-heating	Extract ambient water for several times first, and then extract hot water
	Not enough filtered water in the inner water tank	Wait for a while till "Δ" (Indicator of water filtration) stops flashing
Cannot filter water	The water in the raw water tank is at low level	Change water in the raw water tank. Check if there is any strange noise when filtering
	Raw water tank is not installed properly	Check the raw water tank and install it properly
	Filter cartridge is not installed properly	Disconnect the dispenser from the power supply. Open the filter cartridge lid and take out the filter cartridge, then install it properly
Strange noise when filtering	The water in the raw water tank is at low water level	Change the water in the raw water tank. Check if any strange noise when filtering
	Filtering system is blocked by air	Force rinsing for 1~3 times
	The quality of the raw water does not meet the requirement and the filter cartridge is blocked earlier than expected	Change the filter cartridge and check it again
Leakage	The removable drip tray is full	Empty the removable drip tray
	The check valve on raw water tank base is blocked or rinsed out	Put the check valve back to original place with a thimble, or contact customer services to change it
	The sealing valve at the bottom of the raw water tank is blocked	Hold the sealing valve with a thimble or a finger, remove the blockage
	Water oozes from the dispenser	Disconnect power supply and water source. Please contact customer services
Odd taste of the water	The dispenser is new	Fill the raw water tank, filter the water and empty the filtered water tank. Repeat the process twice
	The dispenser has not been used for a long time	Fill the raw water tank, filter the water and empty the filtered water tank. Repeat the process twice
	Filter cartridge is not changed as required	Change the filter cartridge.
Leakage of electricity	Bad grounding	Must use power socket with reliable grounding
	The power cord is damaged	Please contact customer services
Button/display panel does not respond	Damaged parts	Please contact customer services
	The system halts	Disconnect the dispenser from power supply for 1~2 minutes and then plug it in again

# Error code

Error code	What does it mean	Solutions
E4	Heating element abnormality	Contact customer services
EH	Heating element overheats	Stop using the dispenser and wait for the heating element to cool down to normal temperature. The alarm should stop automatically afterwards, and the error code will disappear
E1	Raw water temperature sensor abnormality	Contact customer services
E2	Heating element temperature sensor abnormality	Contact customer services
E6	The dispenser overflows	Turn off the power for 1-2 minutes, then reconnect the power
		Extract 300ml ambient water, and if the alarm does not stop, contact customer services
EU	Display panel malfunction	Contact customer services

## 11 Guarantee & Service

If you need information or if you have any questions, please visit [www.philips.com/support](http://www.philips.com/support) or contact the consumer care center in your country. If there is no consumer care center in your country, go to a local dealer. Within two years from the date of purchase, you will receive free warranty service for any damage caused by the manufacturing process, or components under normal operation confirmed by our maintenance service. The warranty service does not include frequently replaced consumable components, auxiliary devices, transportation fees, and door-to-door service. Please show the proof of purchase to the service personnel during maintenance.

## 12 Packing list

Dispenser	1x
Removable drip tray	1x
User Manual	1x
Quick Start Guide	1x
Cleaning brush	1x

Please keep this user manual for future reference.

## 目錄

1	產品功能	10	9	濾芯更換	16
2	主要技術參數	10	10	故障診斷	17
3	結構示意圖	11	11	產品保修服務指南	18
4	操作與顯示介面	11	12	裝箱清單	18
5	安裝步驟	12			
6	使用說明	12			
7	注意事項	14			
8	日常保養	15			

# 1 產品功能

本品為檯面式反滲透淨飲機。通過即時加熱技術，在幾秒鐘內能達到您想要的水溫。機身內附有一體複合反滲透濾芯，可去除110種自來水中可能存在的有害物質\*。

\* 其中101種物質的去除率由國際認證檢測機構SGS/BV在實驗室條件下測得，其他9種物質由內部實驗室測得。

# 2 主要技術參數

產品名稱	ADD6915DG
額定電壓	220 V – 240 V ~
頻率	50/60Hz
額定總功率	2300 W
濾芯額定總淨水量	2000 L
適用水源	市政自來水
進水壓力	0 – 0.06 MPa
進水水溫	5 – 38°C
濾水能力	0.13 L/min(25°C)

### 3 結構示意圖

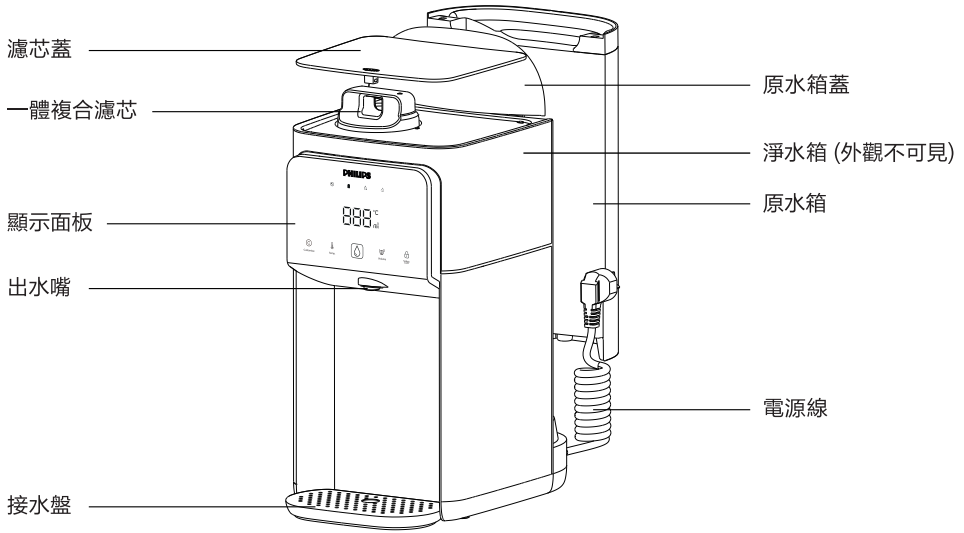

### 4 操作與顯示介面

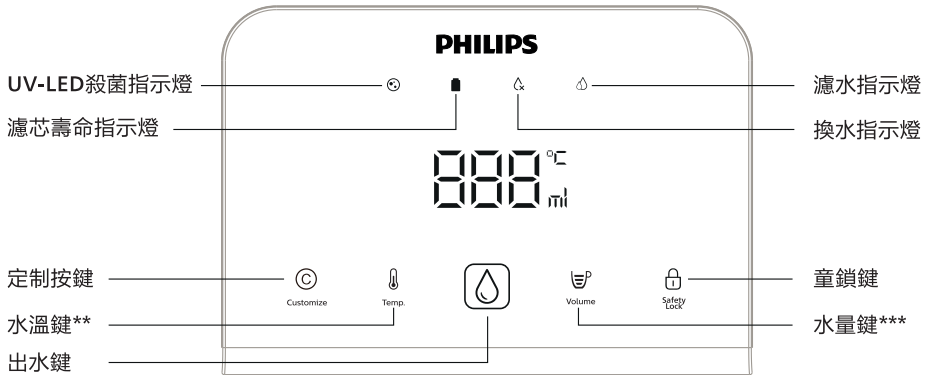

\*\*出水溫度可能存在 $\pm 3^{\circ}\text{C}$ 的溫度誤差，\*\*\*水量可能存在 $\pm 10\%$ 的容量誤差，  
實際出水水溫及水量可能受使用環境及當地水質影響，會存在偏差。

## 5 安裝步驟

### (1) 安裝淨水機

- 請將機器放置在陰涼、通風、穩固的平面上，遠離熱源；
- 打開原水箱蓋，向上提出原水箱，往原水箱注清水後裝回機器，並蓋好原水箱蓋；
- 把電源線插頭插入電源插座，機器發出“嘀”聲並且點亮顯示面板，表示機器進入工作狀態。

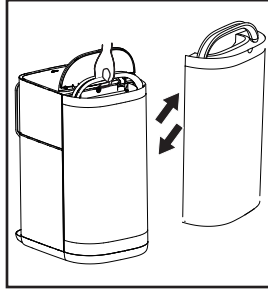
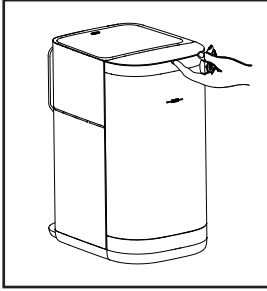

### (2) 首次使用

- 首次使用時，需觀察機器在使用過程中產品內部是否有水流出或周邊積水，機器內部是否有異常聲音、焦糊味、煙等，如發現上述情況請斷開電源連接並與售後人員聯繫。
- 首次使用或長期未使用時，應裝滿水箱，在濾水完成後使用一鍵排空功能，即長按“Ⓜ”（水溫鍵）和“Ⓜ”（水量鍵）3秒，如此反復操作兩次。
- 注意：為防止乾燒，機器首次通電取熱水時，將先取出一段常溫水，再取出熱水。

## 6 使用說明

### (1) 濾水

- 當淨水箱處於低水位狀態時，機器自動進入濾水狀態並持續到濾水完成。當“△”（濾水指示燈）常亮，此時仍可以正常取水，當“△”（濾水指示燈）閃爍時，不可取水。

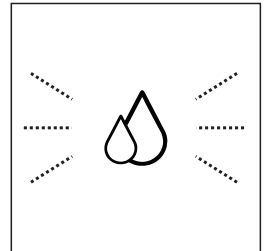

### (2) 取水

- 根據需要選擇水溫、水量，顯示面板顯示當前選擇的水溫，點擊“Ⓜ”（童鎖鍵）（常溫水自動解鎖）後，點按出水即可取出相應溫度、水量的淨水，再點按出水鍵或任意鍵都可停止出水。
- 持續出水：長按出水鍵3秒，持續出水。
- 注意：取熱水時，不可把手伸向出水嘴下方，以免熱水燙傷。

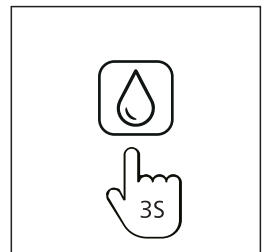



·智慧記憶取水：取水過程若中途手動停止出水，此時“C”（定制按鍵）閃爍，若10秒內點擊“C”（定制按鍵），則“C”（定制按鍵）常亮並記憶當前水溫及已出水水量；“C”（定制按鍵）常亮時，點擊“L”（童鎖鍵）（常溫水自動解鎖）及出水鍵後，可取出記憶水溫水量的淨水；若10秒內未點擊“C”（定制按鍵），則不記憶本次水溫和水量。在正常使用中，點擊“C”（定制按鍵），“C”（定制按鍵）亮起，再點擊“L”（童鎖鍵），解開童鎖（常溫水自動解鎖），可取出記憶水溫水量的淨水。

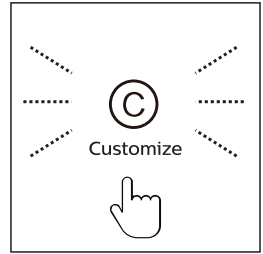

·取水時，出水燈提示燈常亮。

### (3) 換水

當顯示介面中的“L”（換水指示燈）閃爍，表示原水箱需要換水，以下幾種情況會提示換水：

- 原水箱水位達到或低於最低水位線；
- 原水箱超過48小時未換水；

此時應進行換水操作：打開原水箱蓋，向上提出原水箱並將其中的濃縮水倒出，再往原水箱裏注滿水後裝回機器並蓋好。

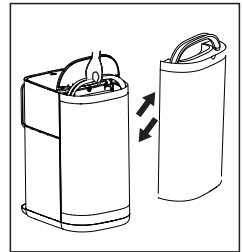
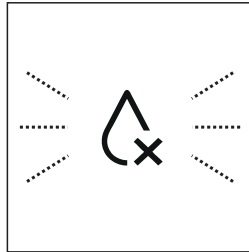

注意：切勿在未倒掉濃縮水的情況下直接往原水箱中加水；原水箱換水後請重新裝回機器，並蓋好原水箱蓋。

### (4) 沖洗

- 機器通電並蓋上原水箱蓋，在機器濾水前和濾水完成後進入沖洗狀態。
- 強制沖洗：同時長按“T”（水溫鍵）+“L”（童鎖鍵）3秒鐘機器自動進入自動沖洗3分鐘。淨水箱處於滿水狀態時不能進行強制沖洗。

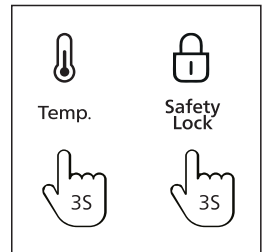

### (5) 一鍵排空

- 長按“T”（水溫鍵）和“V”（水量鍵）3秒，機器進入一鍵排空狀態，此時機器的出水嘴開始出水，直至淨水箱排空。

注意：一鍵排空操作時，請準備大於2L的容器用於接排水。

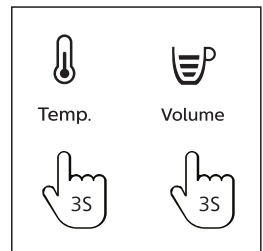

### (6) 冬季模式

- 當原水的水溫低於10°C時，機器可設置冬季模式。
- 長按“⏸”（水溫鍵）3秒，再按取水鍵，可取25°C淨水，僅限單次操作。

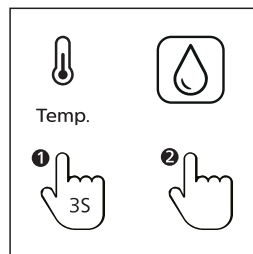

### (7) 抑菌功能

- 開機殺菌：機器每次通電時，UV-LED殺菌模組開始工作1小時後自動關閉。
- 自動殺菌：每次濾水完成，自動殺菌10分鐘。後續機器每隔50分鐘殺菌10分鐘。
- 當UV-LED殺菌模組工作時“☺”（UV-LED指示燈）常亮；當UV-LED殺菌模組不工作時“☹”（UV-LED指示燈）熄滅。

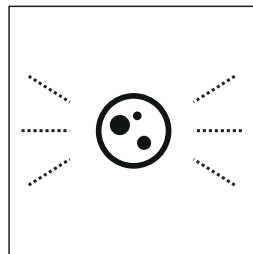

### (8) 休眠模式

- 1分鐘內沒有任何操作，機器進入休眠狀態；
- 機器在休眠狀態中，除“⏸”（童鎖鍵）常亮外其他所有指示燈熄滅，顯示面板顯示為0；
- 機器在休眠狀態中，觸摸任意鍵，喚醒機器

## 7 注意事項

### 警告



- 本產品使用原水水質為市政自來水（不明水源請勿使用）；
- 應看管好兒童，避免他們將產品當作玩具；
- 請務必非常小心地處理濾芯，請勿改裝或跌撞濾芯。如果濾芯已經過改裝、外部損壞或跌撞過，請加以更換；
- 本產品僅限於家用。

### 注意

- 請注意小心輕放，以免產品跌撞造成砸傷；

- 應將本產品放置在穩固、平坦、水平的表面上；
- 本機器應放置於室內陰涼乾燥的地方，避免陽光直射，擺放位置不應靠近暖氣設備、電熱產品或其他高溫場所；
- 機器擺放位置不得處於會出現或有可能出現可燃性氣體洩露的場所；
- 切勿用濕手插拔電源插頭，以免引發觸電危險；
- 請勿自行拆卸、改裝機器或在機器上放置重物，以免損壞淨水機；
- 長時間不使用機器，務必斷開電源，排空原水箱和淨水箱的水；
- 本機器進水溫度要求5-38℃，進水溫度超過38℃時，會損壞濾芯，使濾芯失效；進水溫度低於5℃時，可能造成凍結，引起機器原配件破裂；
- 本機器僅適用於室內安裝與使用，必須使用可靠接地的插座；
- 初次使用或長期停用後，須按初次使用指引排空淨水箱兩次，清洗完畢後，方可使用；
- 本機器的維修保養需使用指定的部件或配件；
- 嚴禁使用汽油等有機溶劑擦拭本機外殼，確需清潔時，應斷電後用濕抹布輕擦本產品表面；
- 倘若發生故障，應立即關掉電源，切勿將有缺陷的機器置於工作狀態；
- 隨著產品的升級，說明書上的某些文字或圖案，可能與實際有所不同，請以產品實物為準；
- 建議在海拔高度不高於1200米的地區使用本機器；
- 如果用戶先取熱水後馬上取常溫水或45℃的水，機器會先出一段殘留熱水，請注意防止燙傷，建議先放常溫水10秒後再取水；
- 如果電源軟線損壞，請停止使用機器，為了避免危險，必須由製造商的專業人員更換；
- 請勿擅自拆解維修本機器或交由非授權的售後人員維修，因不當的維修可能造成危險。

## 8 日常保養

- (1) 如果兩天以上未曾使用機器，建議更換原水箱的水並進行兩次一鍵排空操作（長按“”（水溫鍵）和“”（水量鍵））。
- (2) 如果計劃長期（一周左右）不使用機器，請先排空原水箱中和水箱裏的水，斷開電源並將濾芯密封好，放入冰箱保鮮室保存（攝氏2-5度，切勿放冰格），再次使用時，請按首次使用的步驟清洗。
- (3) 原水箱清洗

當原水箱底部出現沉積物時，需用水進行沖洗，如無法沖洗乾淨，請使用配套的清潔刷進行清潔。建議最少每週使用清潔刷清潔原水箱一次。

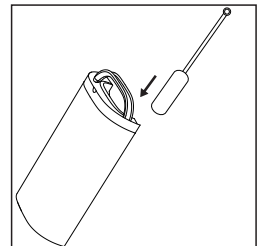

## 9 濾芯更換

請根據顯示幕濾芯壽命提示或建議更換週期更換濾芯。新的濾芯可從經授權的經銷商處或服務中心購買，其型號為：ADD550。

名稱	型號	建議更換週期
一體複合濾芯 (AquaShield)	ADD550	1年

僅可使用原裝飛利浦濾芯進行更換。

### (1) 濾芯壽命顯示

“■” (濾芯壽命指示燈) 顏色代表濾芯剩餘壽命概況，藍色時，表示濾芯剩餘壽命大於10%，紫色時，表示濾芯剩餘壽命小於10%；紅色時，表示濾芯剩餘壽命小於7天或壽命到期。

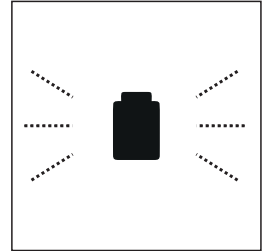

### (2) 濾芯更換步驟

- 拔出電源。
- 按下濾芯蓋按鈕，濾芯蓋彈出。
- 將需要更換的濾芯逆時針旋轉至開鎖位置並提出。
- 將新的濾芯塞進機器並順時針旋入至鎖上位置，然後蓋上濾芯蓋。
- 恢復機器電源，長按“☰” (童鎖鍵)和“☒” (水量鍵) 鍵3秒鐘時間 (樂音提示3聲) 重置濾芯壽命計算器，濾芯指示燈恢復藍色。
- 按首次使用進行兩次一鍵排空操作。

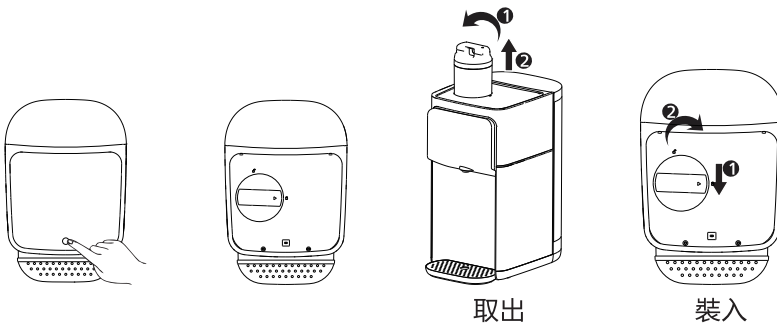

# 10 故障診斷

故障現象	故障可能的原因	解決方案
不能取常溫水	機器未通電	檢查電源連接是否正常
	按鍵未觸摸到位	重新觸摸按鍵進行取水操作
	淨水箱 (非原水箱) 缺水	檢查顯示面板, 如果“△”(換水指示燈)閃爍請提出原水箱進行換水, 然後等待濾水完成後再進行取水操作
不能取熱水	機器處於“乾燒警報”狀態中	先取用幾次常溫水, 再取其他溫度的熱水
	淨水箱 (非原水箱) 缺水	等待片刻, 當“△”(濾水指示燈)常亮或熄滅顯示時即可正常取熱水
機器不濾水	原水箱水位處於低水位狀態	請提出原水箱進行換水, 然後觀察濾水時是否有異常聲音
	原水箱未安裝到位	檢查原水箱是否正確安裝
	濾芯未安裝到位	拔出電源, 打開濾芯蓋, 將濾芯拆下後重新安裝到位
濾水聲音異常	原水箱水位處於低水位狀態	請提出原水箱進行換水, 然後觀察濾水時是否有異常聲音
	濾水系統氣堵	啓動“強制沖洗”1-3次, 把氣堵排除
	水質較硬較差, 濾芯提前堵塞	更換濾芯後重新觀察
機器漏水	接水盤已滿, 接水盤中的水溢出	清空接水盤
	原水箱座單向閥異物卡住或沖出	用小頂針將單向閥調整歸位或聯繫售後人員更換單向閥
	原水箱底部密封閥被異物卡住	用小頂針或手指頂住密封閥動作, 將異物移除
	機器內部滲漏	關閉電源及水源, 請聯繫售後人員
水中有異味	剛開始使用的新機器	注入新鮮自來水到原水箱, 待濾水完成並排空淨水箱, 重複兩次。
	機器長時間未使用	待濾水完成並排空淨水箱, 重複兩次。
	濾芯未及時更換	更換濾芯
漏電及機身帶感應電	機器接地不良	必須使用有可靠接地的插座
	電源軟線破損	請聯繫售後人員
按鍵/顯示屏無反應	機件損壞	請聯繫售後人員
	系統死機	關閉電源1-2分鐘, 再重新連接電源

# 故障代碼

故障代碼	故障原因	解決方案
E4	加熱體異常	聯繫售後維修人員
EH	加熱體高溫	暫停使用，等待加熱體溫度恢復正常後，該警報會自動解除，EH消失
E1	原水溫度探測器異常	聯繫售後維修人員
E2	加熱體溫度探測器異常	聯繫售後維修人員
E6	濾水異常警報	關閉電源1-2分鐘，再重新連接電源
		取300ml常溫水，如仍然無法解除警報，請聯繫售後維修人員
EU	顯示面板失靈	聯繫售後維修人員

## 11 產品保修服務指南

如果您需要信息或有任何問題，請訪問 [www.philips.com/support](http://www.philips.com/support) 或聯繫您所在國家/地區的消費者服務中心。如果您所在的國家/地區沒有消費者服務中心，請聯繫當地經銷商。自購買之日起兩年內，因製造過程問題造成的任何損壞，或經我們維修服務人員確認的在正常使用狀況下的部件損壞，您將獲得免費保修服務。保修服務不包括經常更換的耗材、輔助設備、運輸費用和上門服務。維修時請向服務人員出示購買憑證。

## 12 裝箱清單

主機	1x
接水盤	1x
使用說明書	1x
快速入門指南	1x
清潔刷	1x

請保留此說明書以便查閱





Register your product and learn more in the website link below:  
[www.philips.com/welcome](http://www.philips.com/welcome)

**Specifications are subject to change without notice**

© 2021 AquaShield

All rights reserved.

The Philips trademark and the Philips Shield Emblem are registered trademarks of Koninklijke Philips N.V. used under license.

This product has been manufactured by and is sold under the responsibility of Hong Kong AquaShield Health Technology Company Limited and Hong Kong AquaShield Health Technology Company Limited is the warrantor in relation to this product.

Rev A NOV 21

