

BSC601



EN User manual
ZH-CN 用户手册
ZH-TW 使用手冊

PHILIPS



Specifications are subject to change without notice
© 2018 Koninklijke Philips N.V.
All rights reserved.

3000 014 18261

English

1 Introduction

Congratulations on your HydraCube purchase and welcome to Philips! The Philips HydraCube portable mist enhances the existing moisturizing routine and provides an instant hydration. Enjoy moisturizing and refreshing your skin anytime anywhere!

2 Important

Read this user manual carefully before you use the appliance and keep it for future reference.

- Keep the appliance and the USB cable dry.
- If you want to charge the appliance with a supply unit, only use the supplied cable.
- Do not insert material into the USB socket to avoid short circuiting.
- Do not use the USB cable if it is damaged.
- If the water enters your eyes and causes uncomfortable feeling, stop using the product immediately and consult physician if necessary.
- Always use distilled/purified water. Do not use tap water or any uncleaned water. Do not add toner and other cosmetic products to the appliance.
- Do not use hot water. Always use water in cool or room temperature.
- Do not use the appliance with self-made cleansers, creams, oils or cosmetic products containing harsh chemicals or rough particles.

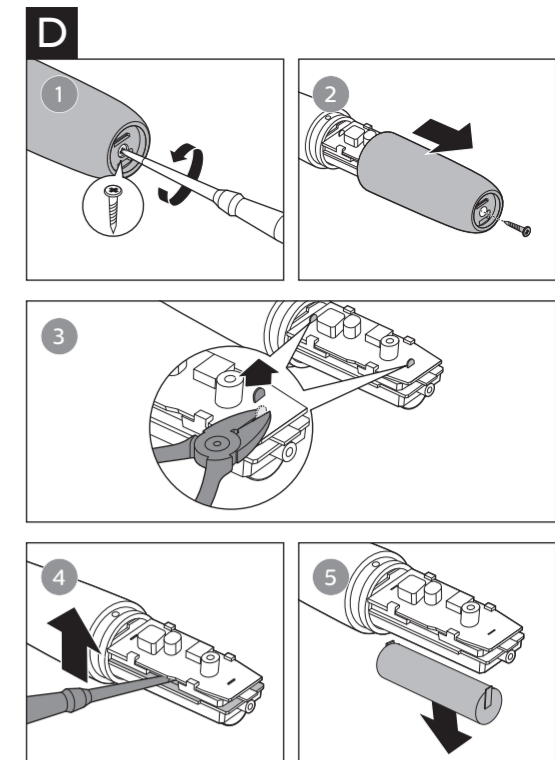
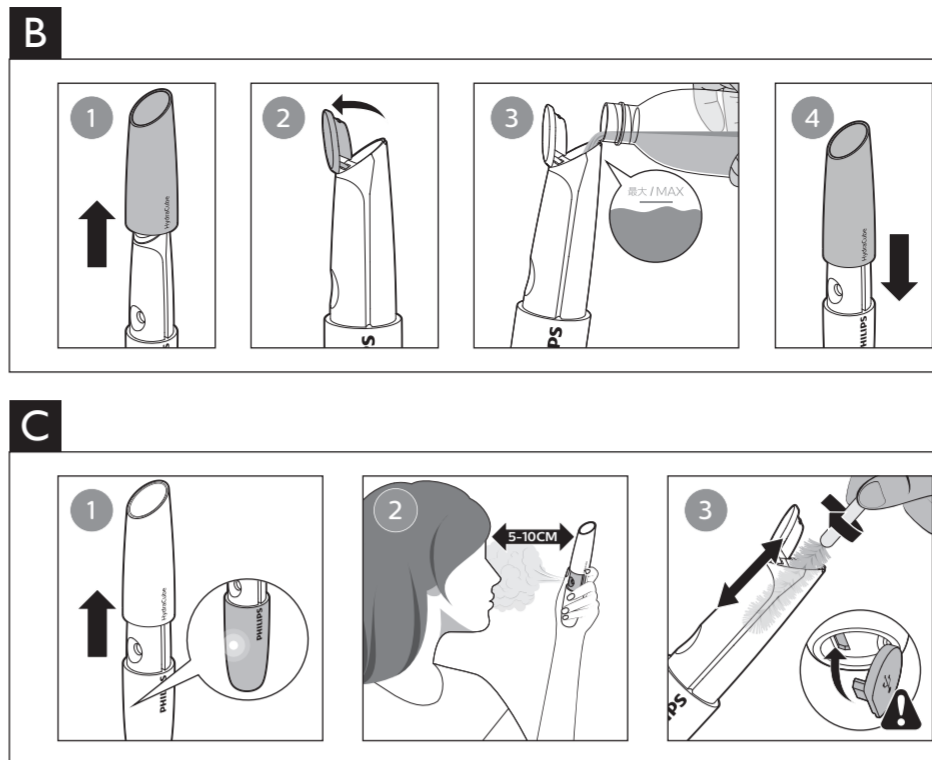
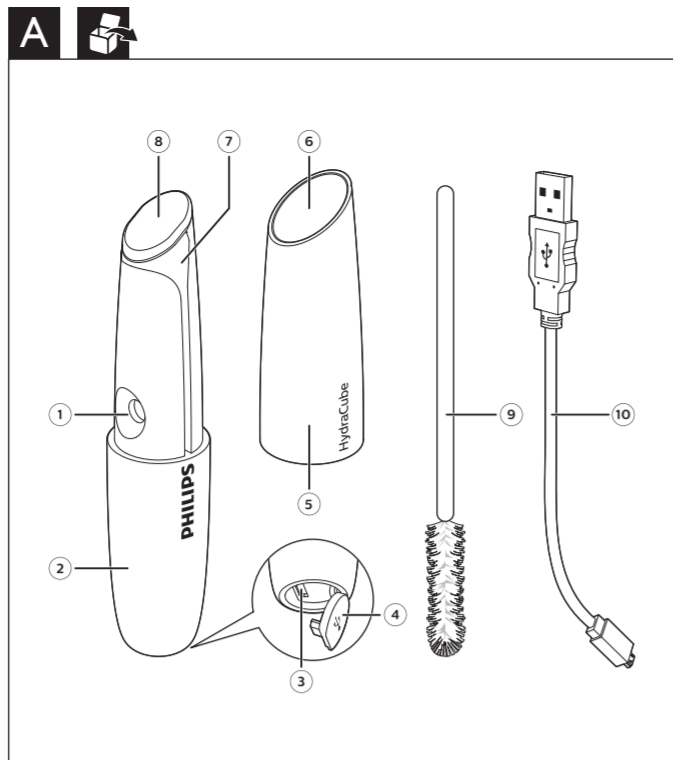

- Regular cleaning of the appliance ensures optimal results and a longer life of the appliance.
- If you do not use the appliance for a certain period of time, dispose any remaining water out and air dry them.
- Do not block the nozzle of the mist while in use.
- Do not put the appliance or any part in the dishwasher.
- Do not immerse the appliance into water for cleaning/descaling or for other purpose.
- For hygienic reasons, we advise you not to share the appliance with other people.
- Only use the appliance as described in this user manual.
- If you have any skin reactions after use (itch or pain), stop using the product and consult your physician.
- If you have a significant skin condition, consult your physician before you start using the appliance.
- This appliance can be used by children aged from 8 years and above and persons with reduced physical, sensory or mental capabilities or lack of experience and knowledge if they have been given supervision or instruction concerning use of the appliance in a safe way and understand the hazards involved. Children shall not play with the appliance. Cleaning and user maintenance shall not be made by children without supervision.
- Stay away from magnetic source to prevent from unintended operation.
- This appliance contains battery that is non-replaceable.
- This appliance must only be supplied at safety extra low voltage corresponding to the marking on the appliance.

Electromagnetic fields (EMF)

This Philips appliance complies with all applicable standards and regulations regarding exposure to electromagnetic fields.

Recycling

- This symbol means that this product shall not be disposed of with normal household waste (2012/19/EU).
- This symbol means that this product contains a built-in rechargeable battery which shall not be disposed of with normal household waste (2006/66/EC). We strongly advise you to take your product to an official collection point or a Philips service centre to have a professional remove the rechargeable battery.
- Follow your country's rules for the separate collection of electrical and electronic products and rechargeable batteries. Correct disposal helps prevent negative consequences for the environment and human health.
- Do not throw away the product with the normal household waste at the end of its life, but hand it in at an official collection point for recycling. By doing this, you help to preserve the environment.
- This product contains a built-in rechargeable battery which shall not be disposed of with normal household waste. The rechargeable battery contains lead.
- Follow the instructions in section 'Removing the rechargeable battery' to remove the battery.

Removing the rechargeable battery

Only remove the rechargeable battery when you discard the product. Before you remove the battery, make sure that the product is disconnected from the wall socket and that the battery is completely empty.

Take any necessary safety precautions when you handle tools to open the product and when you dispose of the rechargeable battery.

Do not connect the appliance to the USB port again after you have removed the battery.

- Remove the USB plugs from the USB port and the appliance.
- Let the appliance run until it stops working.
- (Fig.D-1) Loosen and remove the screw on the bottom of the appliance.
- (Fig.D-2) Take off the body of handle.
- (Fig.D-3,4,5) Cut the battery tags or use a flat-head screw driver to pry it loose and then remove the rechargeable battery carefully.

3 Overview

① Mist outlet	② Handle
③ USB port	④ USB port cover
⑤ Sliding cover	⑥ Mirror surface
⑦ Water tank	⑧ Water tank lid
⑨ Cleaning brush	⑩ USB cable

4 How to use

Before use:

Charging the appliance

Make sure the appliance is fully charged before you use it for the first time. It takes approximately 2.5 hours to fully charge the appliance. A fully charged appliance approximately provides 60 treatments.

- Make sure the sliding cover is closed.
- Insert the micro USB plug in the socket of the appliance and put the USB plug into the charging device. The appliance can't be used while charging. During charging, the indicator blinks white until the battery is full.
- When the battery is fully charged, the charging indicator switches off.

Note: Always close the USB port cover after charging or during cleaning.

Battery-low indicator

When the battery is almost empty (i.e. less than 3 applications), the charging indicator flashes during use. When the battery is empty, the appliance switches off right away.

How to use:

Note: If you wear glasses, make sure you take them off before starting the treatment.

- (Fig.B-1) Remove the sliding cover before filling in water.
- (Fig.B-2) Open the water tank lid.
- (Fig.B-3) Fill in **distilled water** into the water tank.
 - Do not exceed the Max. water level indication.
 - Always use distilled water in the appliance. Other types of water may affect the misting performance.**
 - A full tank will approximately provide 5 treatments.
- (Fig.B-4) Put the sliding cover back.
- (Fig.C-1) To turn on the appliance, push upwards the sliding cover until a "click" is heard.

→ The power-on indicator lights up.

- (Fig.C-2) Place the appliance at the distance of 5-10cm away from your face. Keep moving the appliance in a circular movement and enjoy the mist.

Note: The spray will be automatically stopped after 30 seconds of continuous operation.

7 To turn off the appliance, simply slide the cover back.

Tips and Tricks:

- If further usage is needed, please push the sliding cover downward and then push upwards to re-start the unit.
- If you wish to stop in the middle of the treatment, simply push the sliding cover downwards.
- When the appliance is tilted or upside down, mist may not be able to be generated.
- Mist volume may be different during usage and it is normal to use.
- Wind from air conditioner or electric fan may affect and change mist direction. To optimize misting performance, please avoid wind from air conditioner or electric fan while using the appliance.
- Droplets of water may be generated at mist hole and this is normal. But if many water droplets remain at mist hole, it may affect the mist volume. Please remove water droplets with tissue paper immediately.
- If you plan not to use the appliance for a period of time, clean the unit thoroughly before storage.
- Do not use detergent, nail polisher remover, etc, to clean the appliance.

After use:

- Clean the appliance with tissue paper or clean towel, especially the mist outlet.
- (Fig.C-3) Use the supplied brush to clean the water tank with tap water if necessary.
- It's highly recommended to empty the water tank and clean the appliance every day.
- Always make sure the USB cover is closed before cleaning.**
- Keep it in a safe and dry place.

5 Troubleshooting

This chapter summarizes the most common problems you could encounter with the appliance. If you are unable to solve the problem with the information below, visit www.philips.com/support for a list of frequently asked questions or contact the Consumer Care Center in your country.

Problems	Solution
The appliance does not charge.	Make sure the socket or the USB port to which you connect the appliance or micro USB is live. If the appliance is fully discharge, please charge the appliance for a few minutes to activate the appliance to charge up. When the charging light on the appliance still does not light up or when the appliance still does not charge, take it to your Philips dealer or the nearest Philips Service Center.
The appliance does not work anymore.	Make sure the sliding cover locked in place. Charge the appliance according to the instructions in this user manual. The appliance cannot operate during charging. Please remove the USB cable.
No mist comes out from the appliance.	Make sure you use distilled water in the appliance. Do not use other type of liquid as it may affect the misting performance. Clean the mist outlet with tissue paper.
The appliance has abnormal noise during use.	The water level may be low, please refill the water tank.
The appliance may start working unconsciously.	Please put it away from magnetic source, such as the lock of your handbag, etc.

6 Guarantee and service

If you need information e.g. about replacement of an attachment or if you have a problem, please visit the Philips website at www.philips.com/support or contact the Philips Consumer Care Center in your country. The phone number is in the worldwide guarantee leaflet. If there is no Consumer Care Centre in your country, go to your local Philips dealer.

繁體中文

1 簡介

恭喜您購買 HydraCube 產品，並歡迎加入飛利浦！飛利浦 HydraCube 可攜式噴霧能加強日常的保溼程序，帶來立即的滋潤效果。隨時隨地為肌膚補充水分，迅速恢復活力！

2 重要事項

使用本產品前，請先仔細閱讀本使用手冊，並保留說明以供日後參考。

- 本產品及 USB 纜線請保持乾燥。
- 如要使用電源供應器為產品充電，僅可使用本產品提供的充電線。
- 請勿將任何物品插入 USB 插孔，以避免短路。
- USB 纜線損壞時，請勿使用本產品。
- 若水進入眼睛後感到任何不舒服，請立即停止使用本產品，並視需要向醫師尋求諮詢。
- 務必使用蒸餾水/純水。請勿使用自來水或不清潔的水。請勿在產品中加入化妝水和其他化妝品。
- 請勿使用熱水。務必使用冷水或室溫涼水。
- 請勿將本產品與自製洗面乳、乳霜、護膚油或含有刺激性化學物質或質地較粗的化妝品一起使用。
- 定期清潔本產品可確保最佳效果，並延長產品的使用壽命。
- 如果一段時間不使用本產品，請將剩餘的水倒掉，並讓產品自然風乾。
- 使用期間，請勿阻塞噴霧噴嘴。
- 請勿使用洗碗機清潔產品或任何零件。
- 請勿因清潔/除垢或其他目的，而將本產品浸泡於水中。
- 基於衛生考量，我們建議您不要和其他人共用本產品。
- 僅可依本使用手冊的說明來使用產品。
- 若使用後引起任何肌膚反應(發癢或疼痛)，請停止使用本產品，並諮詢醫師。
- 如果有重大的皮膚狀況，請在使用本產品之前先向您的醫師諮詢。
- 本產品可供 8 歲以上孩童、身體官能或心智能力退化者，或是經驗與使用知識缺乏者使用，但需要有人在旁監督或適當指示如何安全使用本產品，以及可能遭受的危險。請勿讓孩童把玩本產品。若無人在旁監督，不得讓孩童清潔與維護產品。
- 請遠離磁性來源，以避免發生意外運作。
- 產品中的電池不可更換。

